

**User Guide for**

**FEBSPM3SPM45\_M01MTCA**

**Motion SPM3/45H Evaluation Board**

**Compatible with:**

**SPM3V2\_V4 & SPM45H Modules**

**Featured Fairchild Product:**

**FNB41560 (SPM45H SPM)**

*Direct questions or comments  
about this evaluation board to:  
“Worldwide Direct Support”*

<http://www.fairchildsemi.com/support/evaluationboards/>

## Table of Contents

1. Overview of the Evaluation Board (EVB) .....	3
2. Key Features .....	5
3. Specifications .....	6
3.1. Safety Precautions ***** WARNING ***** .....	7
3.2. Test Configuration #1 .....	9
3.3. Test Configuration #2 .....	10
3.4. Test Configuration #3 .....	11
4. External Connections .....	12
5. Schematics .....	13
6. PCB and Assembly Images .....	19
7. Bill of Materials .....	22
8. Key Parameter Design .....	24
8.1. Current-Sensing Circuit .....	24
8.2. Short Circuit Protection(SCP) Circuit .....	25
9. V <sub>BUS</sub> Sense Circuit .....	26
10. Test Waveforms .....	26
10.1. Bulk Capacitor Ripple Current .....	26
10.2. NTC Temperature .....	27
11. References .....	27
12. Revision History .....	28

This user guide supports the SPM3V2\_V4 / SPM45H evaluation board, identifiable by the marking FEBSPM3SPM45\_M01MTCA on the topside of the PCB. It should be used in conjunction with SPM3V2\_V4 / SPM45H product datasheets, as well as Fairchild Semiconductor's application notes and technical support team available through the website at <http://www.fairchildsemi.com>.

## 1. Overview of the Evaluation Board

This motion Smart Power Module (SPM®) evaluation board is designed to evaluate Fairchild Semiconductor's SPM3V2\_V4 and SPM45H SPM families of parts. The motion SPM is installed as the motor power module on the evaluation board to drive a three-phase AC Induction Motor (ACIM), Brushless DC (BLDC) motor, Brushless AC (BLAC) motor, or Permanent-Magnet Synchronous Motor (PMSM). A Switched-Mode Power Supply (SMPS) is integrated into the design, along with the necessary bulk capacitors and microcontroller (MCU) interface circuitry. This allows evaluation of Fairchild's motion SPM products with a minimum investment of time, expense, and peripheral equipment. As this board is designed for a wide variety of motor types, not all included circuitry is required for all types of motors. Some motor types may require some additional circuitry be added, depending on the control algorithms being implemented.

By default, the FNB41560 (600 V/15 A SPM45H) is installed as the motor power module, as shown in Figure 9. It is possible to replace the provided SPM45H module with a part from the SPM3\_V2 family (i.e. FSBB30CH60, 600 V/30 A) per Figure 10 or the SPM3\_V4 family (i.e. FSBB30CH60C, 600 V/30 A) per Figure 11. Depending on the power level of the device, some additional discrete component value changes may be required. The most common reason to consider a SPM3V2\_V4 device over the SPM45H family is to increase motor power level.

The evaluation board is designed to connect to either AC or DC power sources feeding current to the motor. There are three example test configurations in Section 3. The three-phase motor output terminals (U, V, W) from the SPM should be connected to the motor windings. Three bootstrap power supply circuits are designed into the evaluation board, one per phase. A bootstrap capacitor, charge resistor for charging the capacitor, and the blocking diode for high-voltage isolation make up each bootstrap supply. With SPM45H and SPM3\_V4 modules, R50-55 and D5-7 are not required. These extra bootstrap positions are provided for compatibility with SPM3\_V2 modules.

The microcontroller (MCU) or motion-controller development board connects to this SPM board via the provided connector. Six low-pass filters are used between the signal input connector and the gate input signal pins of the FNB41560. Short-circuit current protection is provided by a single shunt resistor, op amp, and low-pass filter. Additional circuitry is included to monitor bus voltage, inverter phase current, and module temperature. This evaluation board is designed to support a wide array of test conditions and requirements.

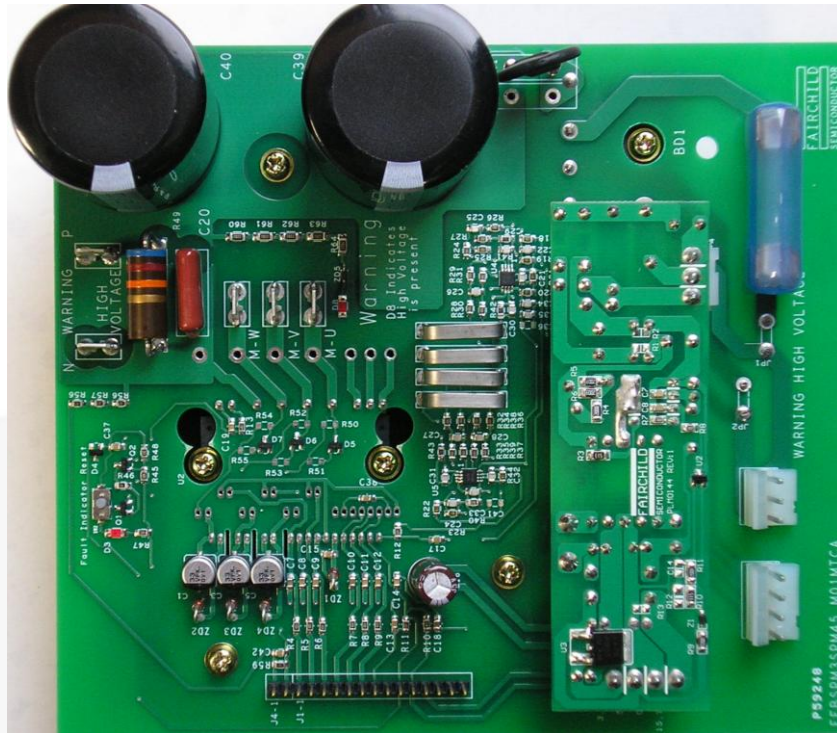


Figure 1. Top View, 140 mm x 160 mm

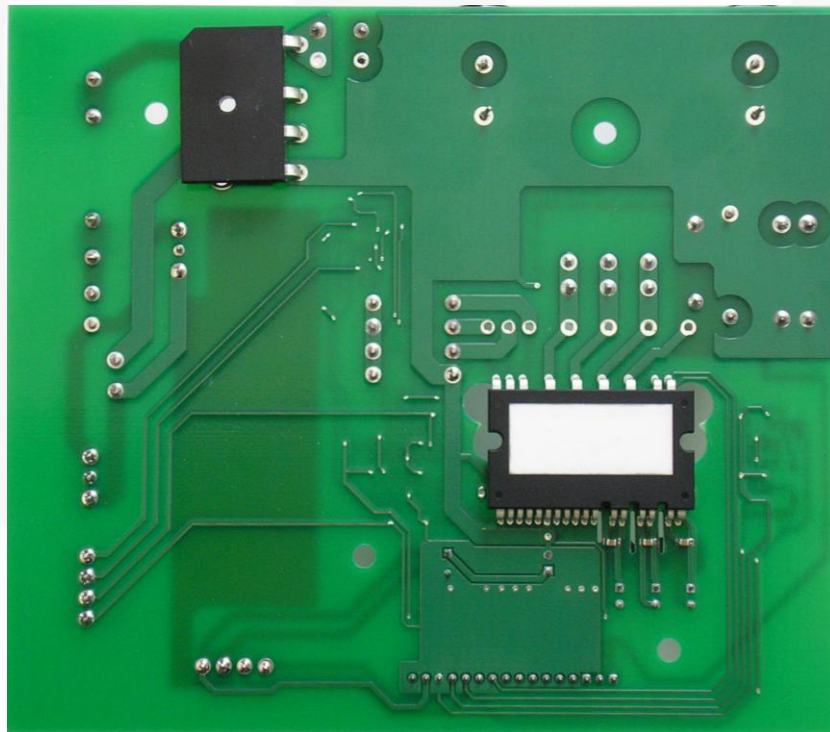


Figure 2. Bottom View, 140 mm x 160 mm

## 2. Key Features

- AC Line Input Connection
- On-Board Bulk Capacitors
- Bulk Capacitor Charge Indicator
- On-Board High-Voltage SMPS
  - $+15.75\text{ V}_{\text{DC}}$ ,  $+5\text{ V}_{\text{DC}}$ ,  $+3.3\text{ V}_{\text{DC}}$  Outputs
- Short-Circuit Current Protection
- Triple Open-Emitter Connections to Negative DC Link
- MCU Interface Connections
  - 3 High-Side, 3 Low-Side Gate Drive Inputs
  - Fault Output
  - Bus Voltage Sense Output
  - 3-Phase Current Sensing, Amplified
- NTC Output Signal (when applicable)
- Current Sense Resistors (when applicable)

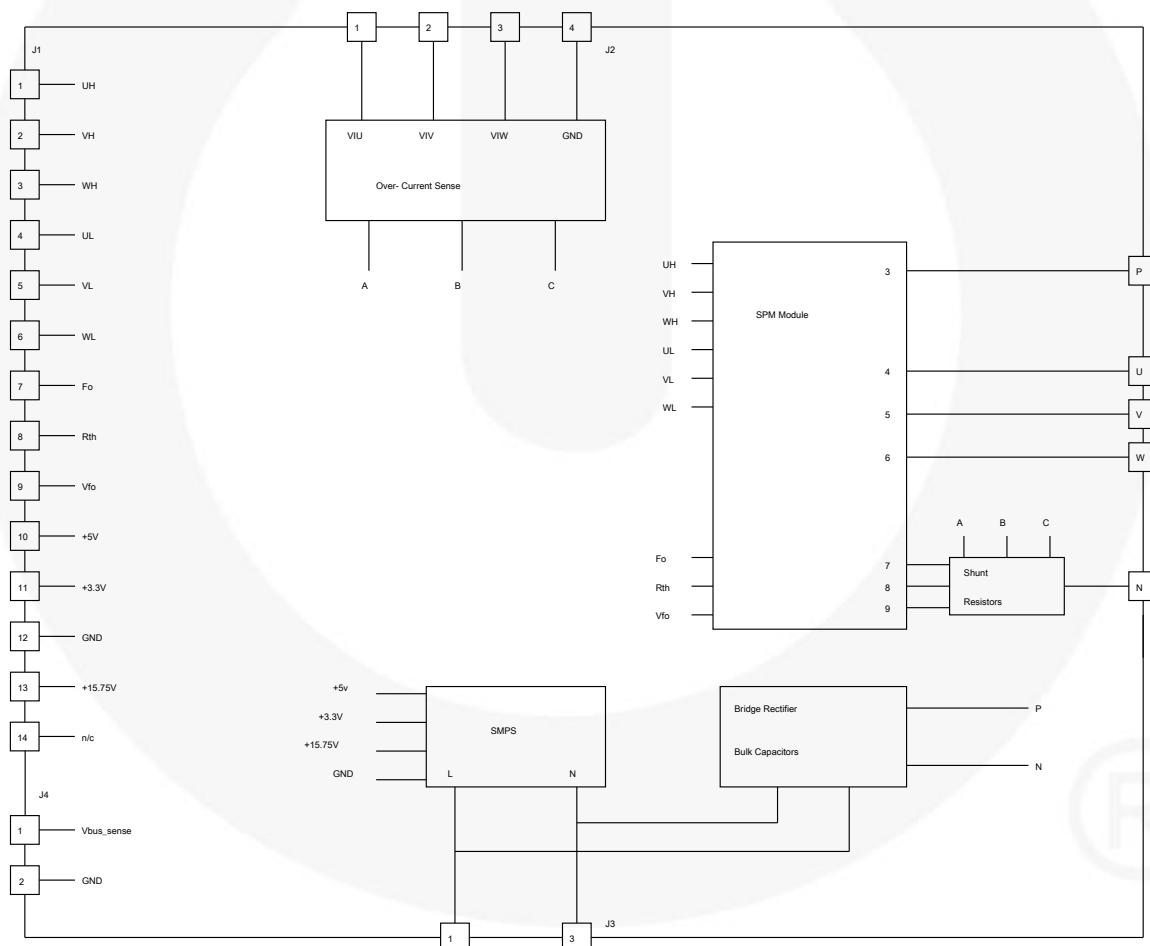


Figure 3. Block Diagram

### 3. Specifications

This evaluation board has been designed and optimized for the conditions in Table 1.

**Table 1. Electrical and Mechanical Requirements**

Evaluation Board			
	Minimum	Maximum	Units
$V_{IN\_AC}$	90	265	$V_{AC}$
$V_{IN\_DC}$	125	390	$V_{DC}$
$f_{IN\_AC}$	50	60	Hz
Output Voltage		390	$V_{DC}$
$I_{OUT}$ (per Phase)		7 <sup>(1,3,4)</sup>	$A_{RMS}$
$I_{OUT}$ (per Phase)		15 <sup>(2,3,4,5)</sup>	$A_{RMS}$
PS1 (SMPS)			
$V_{IN\_AC}$	90	265	$V_{AC}$
$f_{VIN\_AC}$	47	63	Hz
Output Voltage 1		3.3	$V_{DC}$
Output Current 1		0.15	A
Output Voltage 2		5.0	$V_{DC}$
Output Current 2		0.15	A
Output Voltage 3		15.75	$V_{DC}$
Output Current 3		0.06	A

**Notes:**

1. See test configuration 1.
2. See test configuration 2 or 3.
3. A cooling fan may be required when operated for extended periods at high currents. Monitoring heat sink temperature near the thermal interface of the SPM is recommended when testing at high currents to ensure device remains within maximum thermal operating limits.
4. AC input voltage at 220  $V_{AC}$ .
5. This board is supplied with FNB41560 SPM45H motion SPM, rated at 600 V/15 A ( $T_C=25^\circ\text{C}$ , non-switching). In typical applications, the FNB41560 would realistically be limited to 7.5  $A_{RMS}$  ( $T_C=100^\circ\text{C}$ , 16 kHz switching). When the provided SPM is replaced with a high-current part, like the FSBB30CH60C (SPM3), operation to 15  $A_{RMS}$  may be possible. Additional electrical/thermal component changes may be necessary to support the higher currents. See test configurations.

### 3.1. Safety Precautions \*\*\*\*\* WARNING \*\*\*\*\*



Before applying power to the FEBSPM3SPM45\_M01MTCA evaluation board, it is imperative that all involved personnel read and understand the safety precautions and understand the power on/off procedures.

The FEBSPM3SPM45\_M01MTCA evaluation board operates at lethal voltages and has bulk capacitors that store significant charge. Accidental contact can lead to lab equipment damage, personnel injury, and may be fatal. Please be exceptionally careful when probing and handling this board. Always observe normal laboratory precautions, including:

- All connected computers and measurement equipment **MUST** be isolated from the AC mains before operating voltages are applied to the board. Alternatively, AC/DC power to the board may be isolated.
- When using an oscilloscope with this board, it must be isolated from the AC line. Alternatively, high-voltage (700 V+) isolated probes may be utilized.
- See Figure 4 and Figure 5 for areas on the board that must be avoided due to the presence of HIGH VOLTAGES. When bulk capacitors are charged, avoid contact with board circuitry.
- Start with a clean working surface, clear of any conductive material.
- Be careful while turning on the power switch to the AC source.
- Never probe or move a probe on the board while the AC line voltage is present.
- LED D8 indicates high voltage is present on the high-voltage bus. Be aware!
- Ensure the bulk capacitors are discharged before disconnecting the AC motor and the MCU. One way to do this is to remove the main power source while the motor is still motoring with the MCU active. The motor then discharges the output capacitors and the module is safe to disconnect.

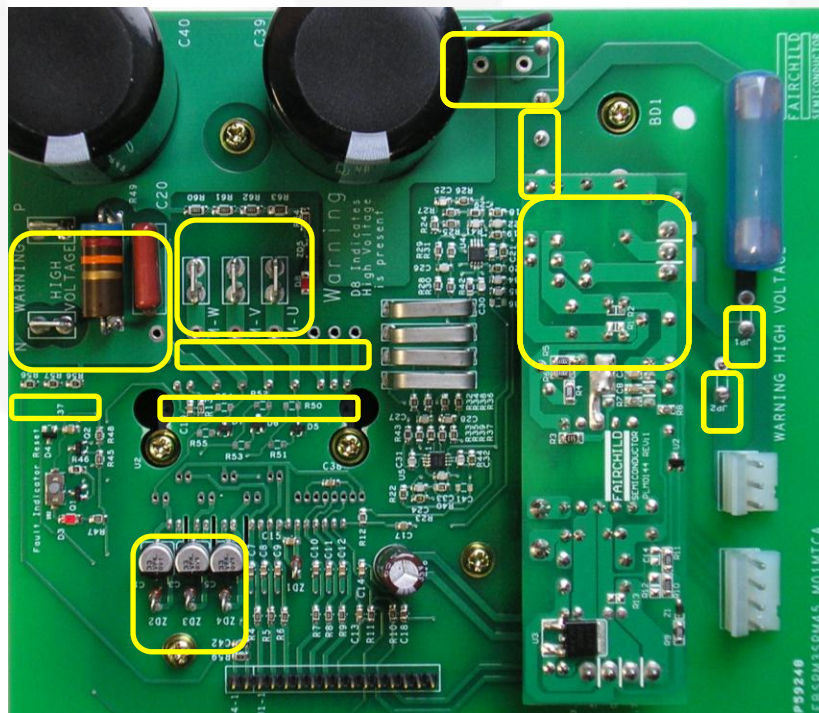
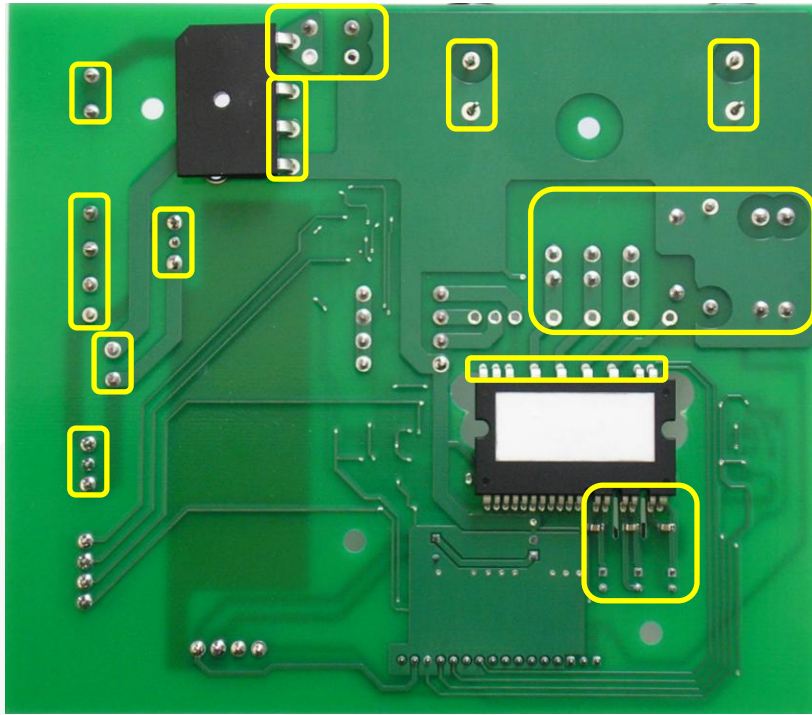


Figure 4. High Voltage Areas (Top Side)



**Figure 5. High-Voltage Areas (Bottom Side)**



### 3.2. Test Configuration #1

Use this configuration for motor current less than 7 A<sub>RMS</sub>. This is the default configuration (see Figure 6).

1. Attach the 3-phase motor and MCU connections.
2. Connect the AC line voltage to J3 to charge the bulk capacitors and operate the SMPS. The SMPS does not operate until the AC input voltage is greater than 90 V<sub>AC</sub>.
3. Fault indicator LED (D3) turns on when AC power is initially applied.
4. Press switch SW2 to reset the fault-detect circuit, turning off fault indicator D3.
5. Operate the MCU firmware to rotate the motor. More advanced control algorithms may require additional connections to the MCU (i.e.: phase current sensing, motor winding BEMF sensing, and bus voltage sensing).

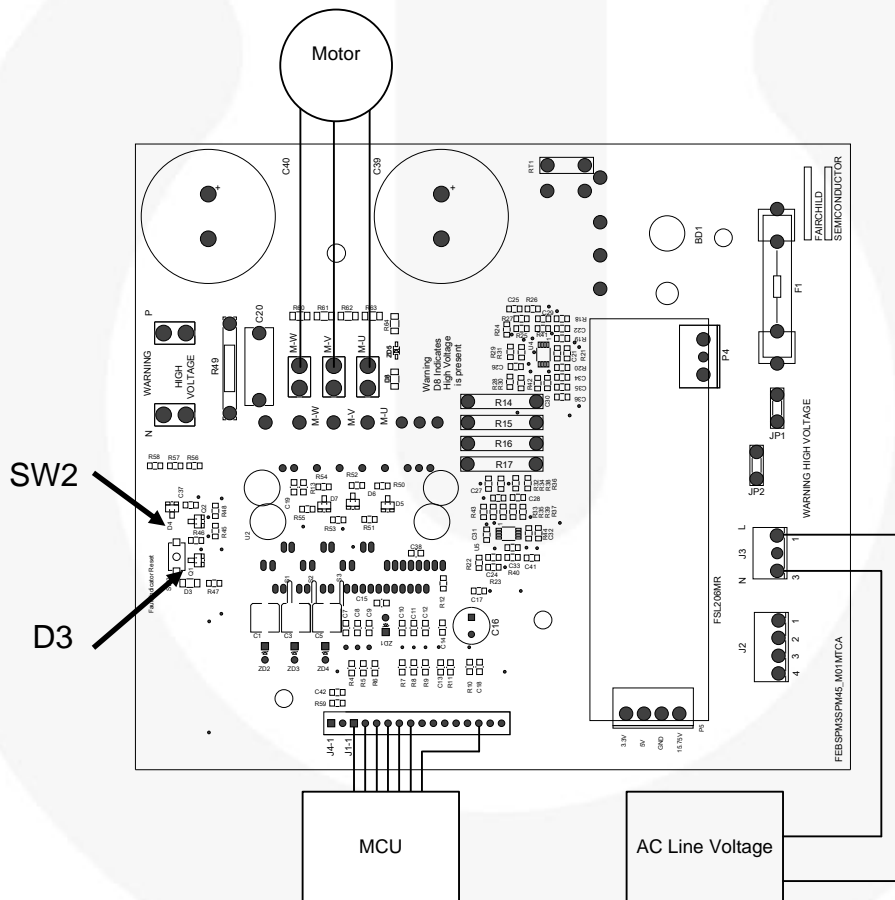


Figure 6. Test Configuration #1

### 3.3. Test Configuration #2

Use this configuration for motor currents greater than 7 A<sub>RMS</sub>. Modifications are required (see Figure 7).

1. Additional cooling and/or larger heat sink is required.
2. Variable transformer is recommended to slowly ramp V<sub>AC</sub> input to bulk capacitors.
3. Make a short connection in parallel with RT1, using RT2 mounting holes.
4. Attach a three-phase motor and MCU connections.
5. Connect the AC line voltage to J3 through a variable transformer to charge the bulk capacitors and operate the SMPS. The SMPS does not operate until the AC input voltage is greater than 90 V<sub>AC</sub>.
6. Slowly adjust the variable transformer for the desired AC voltage.
7. Fault indicator LED (D3) turns on when AC power is initially applied.
8. Press switch SW2 to reset the fault-detect circuit, turning off fault indicator D3.
9. Operate the MCU firmware to rotate the motor. More advanced control algorithms may require additional connections to the MCU (i.e.: phase current sensing, motor winding BEMF sensing, and bus voltage sensing).

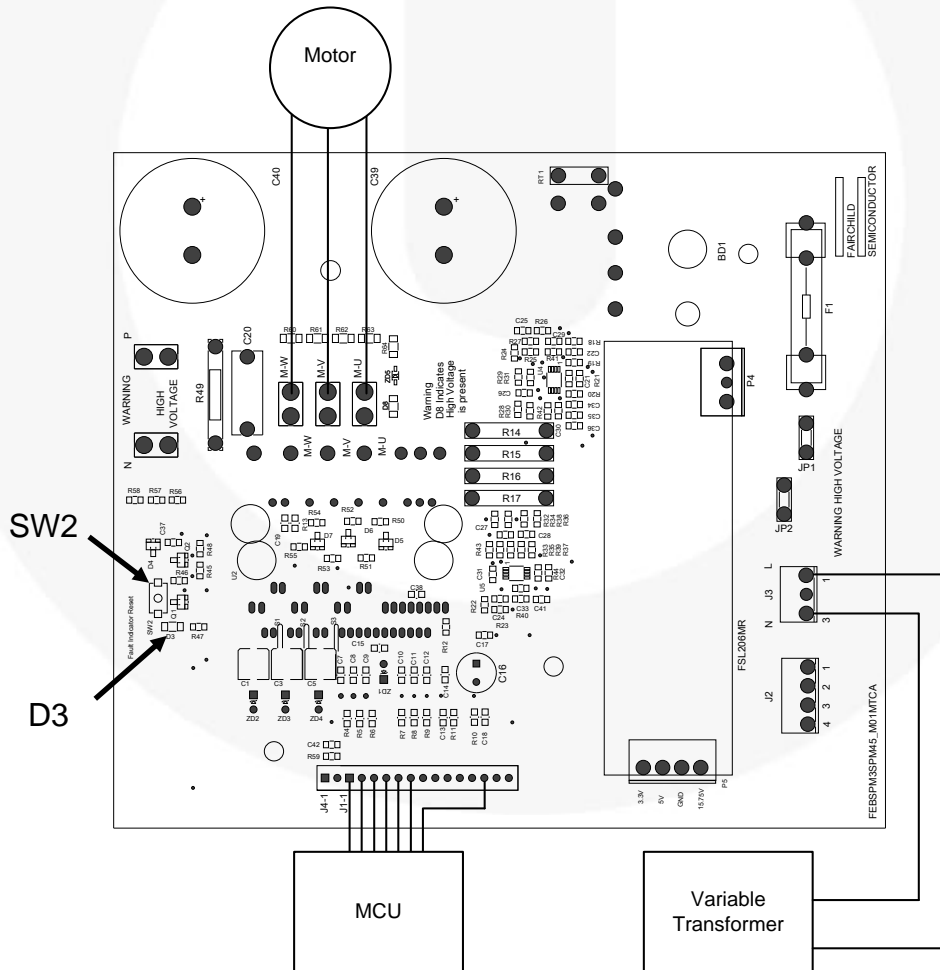


Figure 7. Test Configuration #2

### 3.4. Test Configuration #3

Use this configuration for motor currents greater than 7 A<sub>RMS</sub>. Modifications are required (see Figure 8).

1. Additional cooling and/or larger heat sink is required.
2. Remove JP1 and JP2 AC line jumpers. This removes power to the bridge rectifier. The AC line voltage is only applied to the SMPS.
3. Attach the three-phase motor and MCU connections.
4. Connect the AC line voltage to J3 to power the SMPS.
5. Fault indicator LED (D3) turns on when AC power is initially applied.
6. Press switch SW2 to reset the fault-detect circuit, turning off fault indicator D3.
7. Connect an isolated high-power DC power supply to the P and N terminals.
8. Adjust the DC supply for the desired DC voltage.
9. Operate the MCU firmware to rotate the motor. More advanced control algorithms may require additional connections to the MCU (i.e.: phase current sensing, motor winding BEMF sensing, and bus voltage sensing).

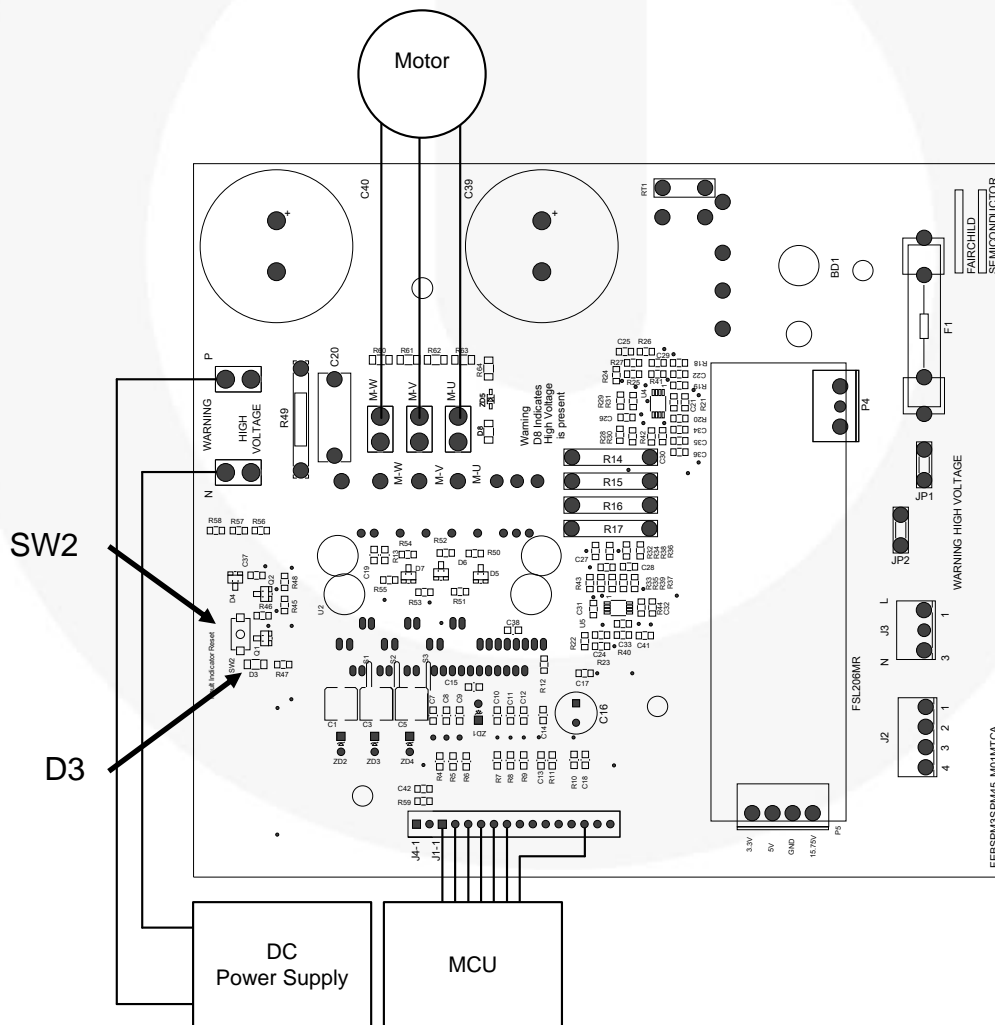


Figure 8. Test Configuration #3

### 3.5. Power-Off Procedure

1. Remove the AC line voltage or high-power DC power supply while the MCU is enabled.
2. Allow the motor to discharge the bulk capacitors, as indicated by D3 going off when the bus capacitors are fully discharged. It is good practice to have an isolated DMM attached to the board to ensure the bus voltage is at a safe level prior to handling or manipulating electrical connections.

## 4. External Connections

Signal Interface	Pin	Function
J1	1	High-Side Input Signal from MCU (Phase U), active HIGH
	2	High-Side Input Signal from MCU (Phase V), active HIGH
	3	High-Side Input Signal from MCU (Phase W), active HIGH
	4	Low-Side Input Signal from MCU (Phase U), active HIGH
	5	Low-Side Input Signal from MCU (Phase V), active HIGH
	6	Low-Side Input Signal from MCU (Phase W), active HIGH
	7	Fault-Out Signal to MCU, active LOW
	8	R <sub>TH</sub>
	9	V <sub>FO</sub> , active LOW
	10	SMPS +5 V Output
	11	SMPS +3.3 V Output
	12	GND
	13	SMPS +15.75 V Output
	14	N/C
J2	1	Current-Sense Output (Phase U)
	2	Current-Sense Output (Phase V)
	3	Current-Sense Output (Phase W)
	4	Signal GND
J3	1	AC Line Input (Hot)
	3	AC Neutral Input (Neutral)
J4	1	+Bus Voltage Sample Output
	2	-Bus Voltage Sample Output
¼" Spade Terminals	P	Positive DC Link Input Connection
	N	Negative DC Link Input Connection
	U	Motor Output Connection (Phase U)
	V	Motor Output Connection (Phase V)
	W	Motor Output Connection (Phase W)

## 5. Schematics

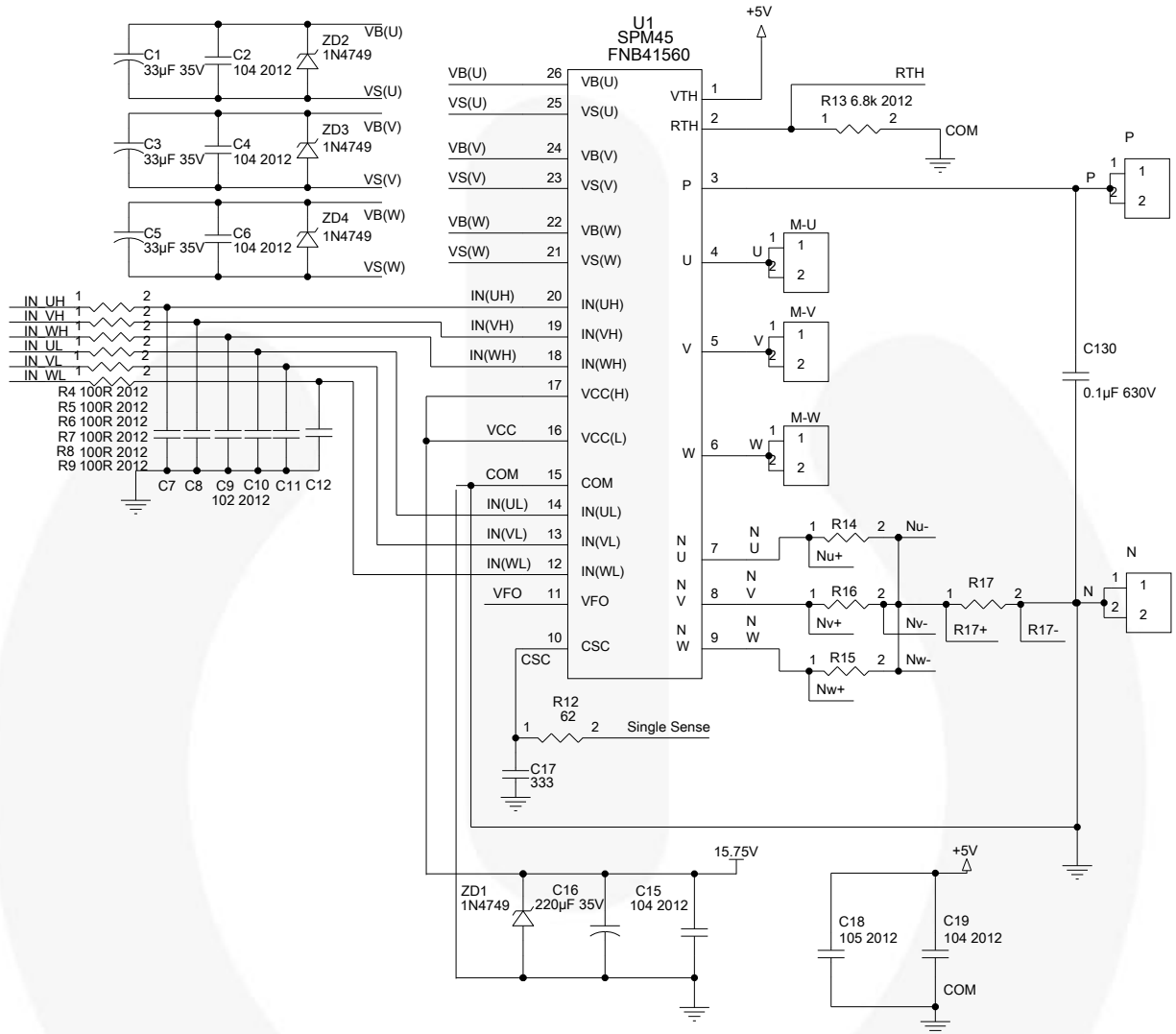
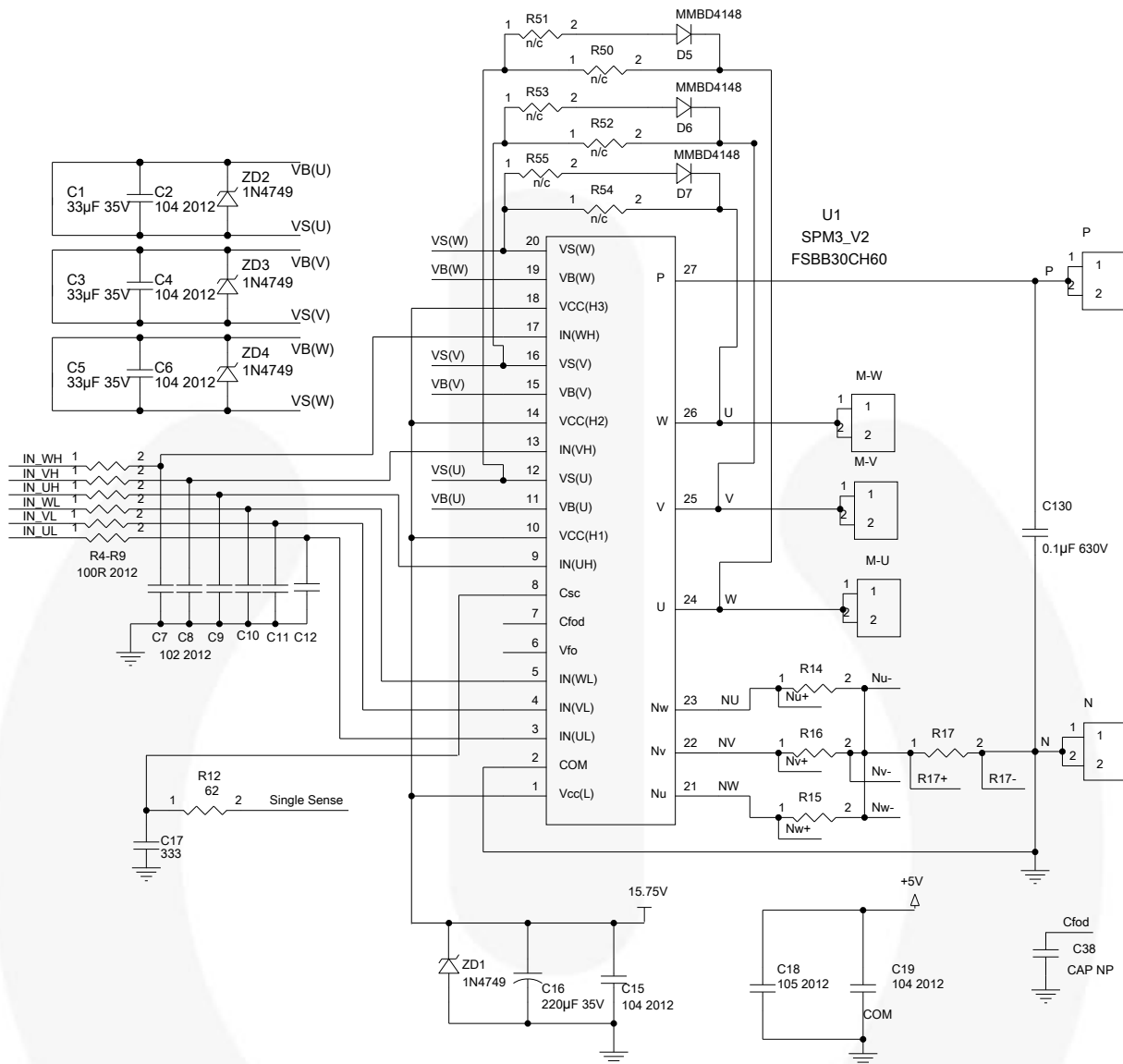
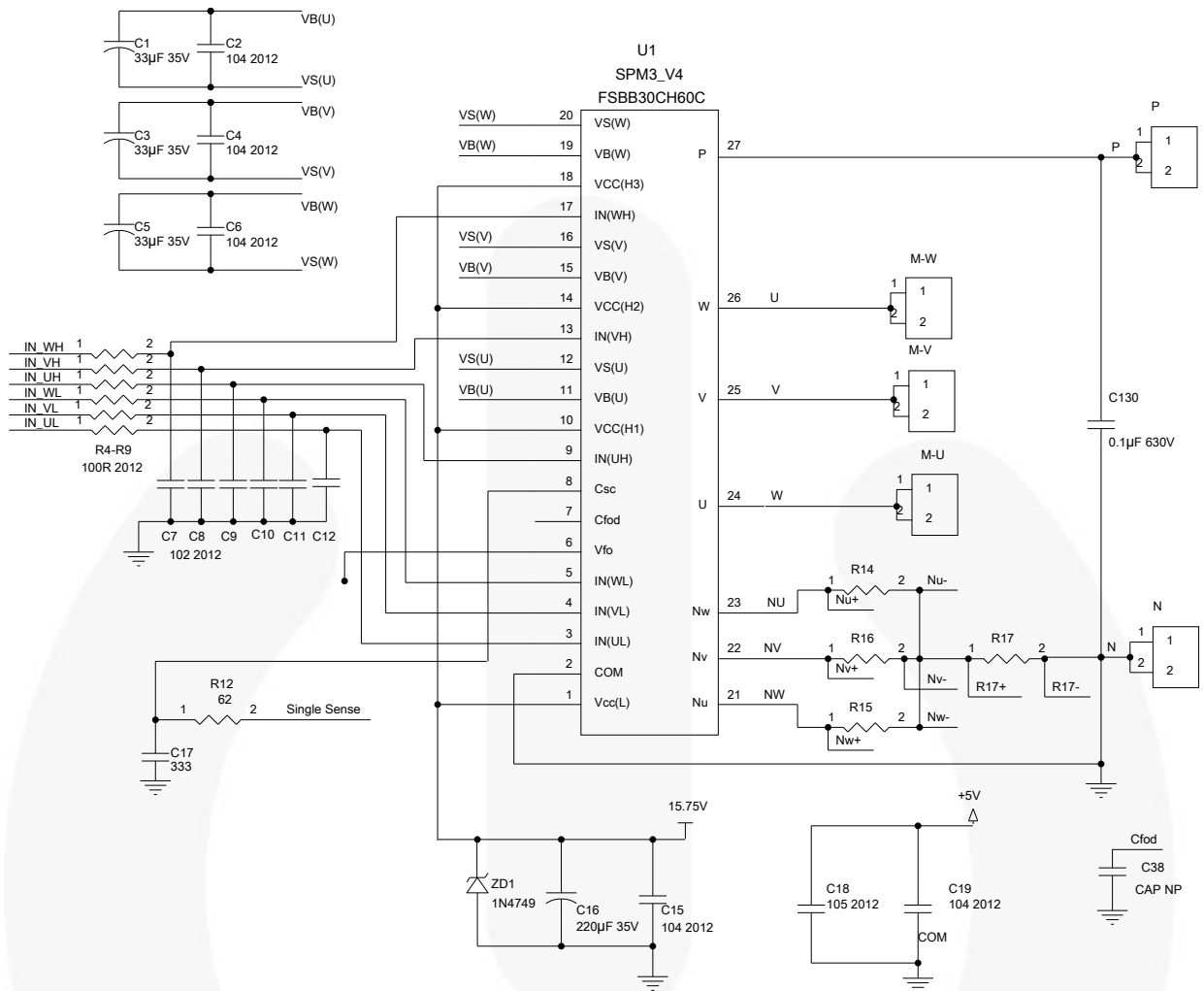


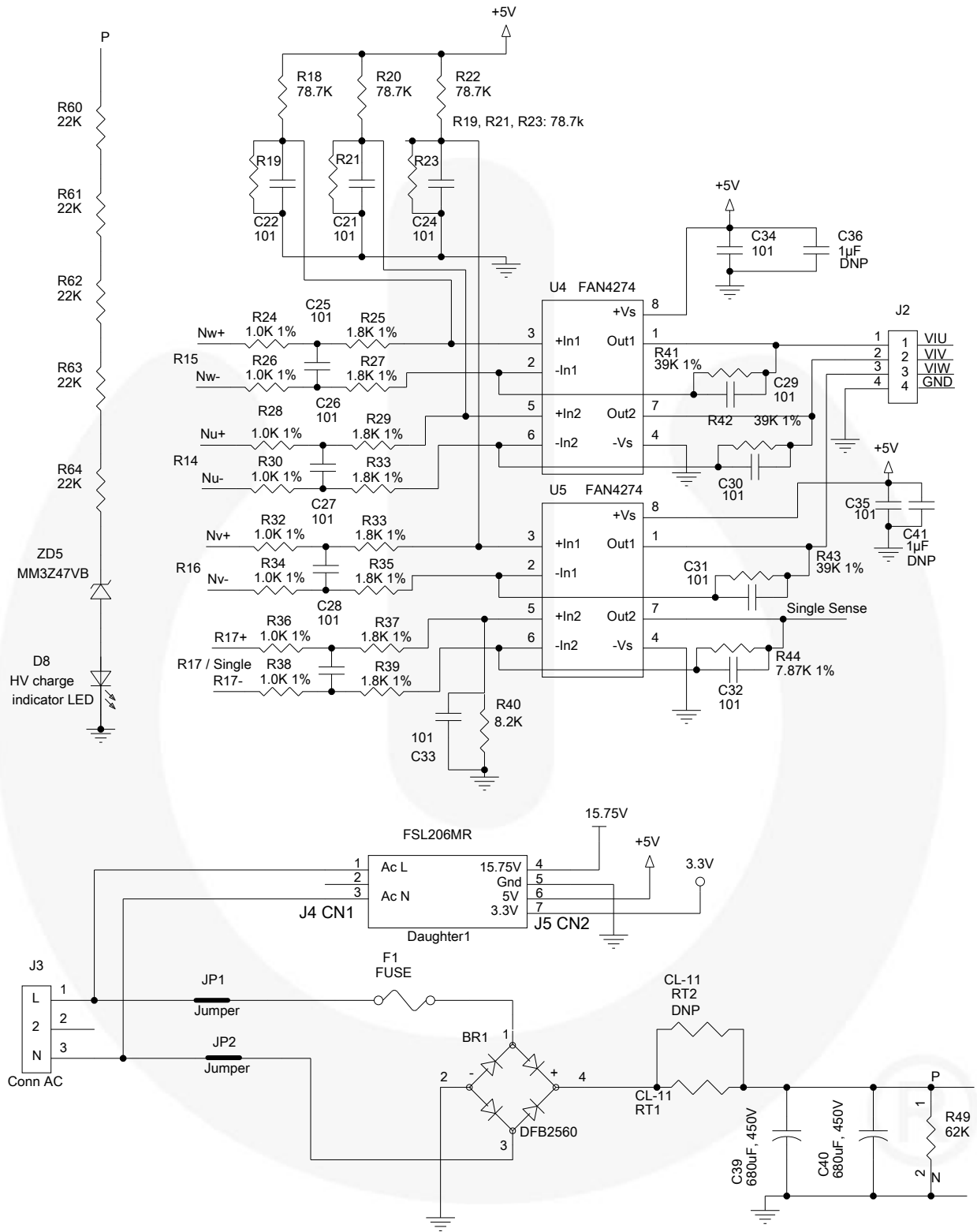
Figure 9. FEBSPM3SPM45\_M01MTCA with SPM45



**Figure 10. FEBSPM3SPM45\_M01MTCA with SPM3\_V2**

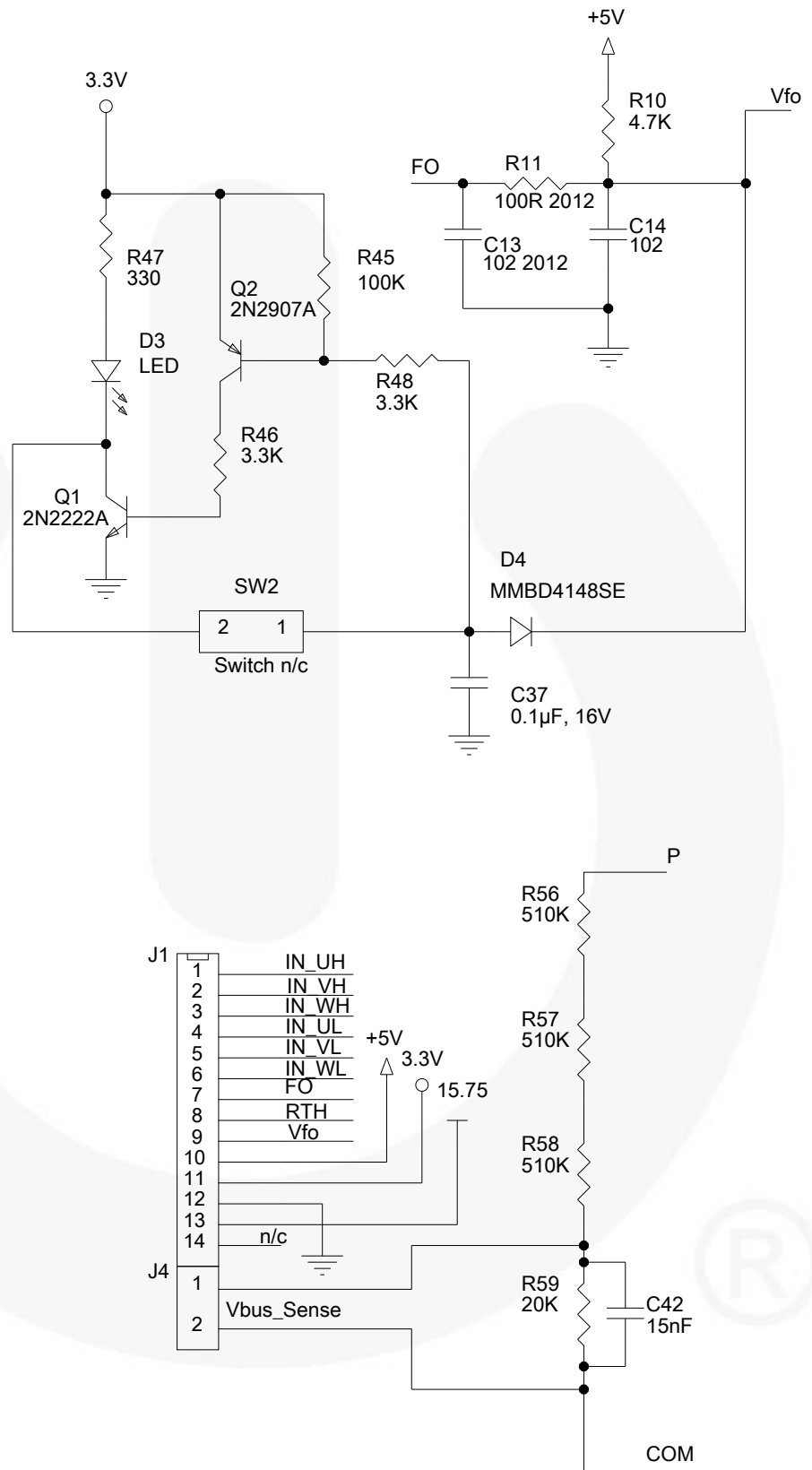


**Figure 11. FEBSPM3SPM45\_M01MTCA with SPM3\_V4**



**Figure 12. Power Supply, HV Charge Indicator and Current Sense**





**Figure 13. Fault, V<sub>BUS\_SENSE</sub>, J1 and J4**

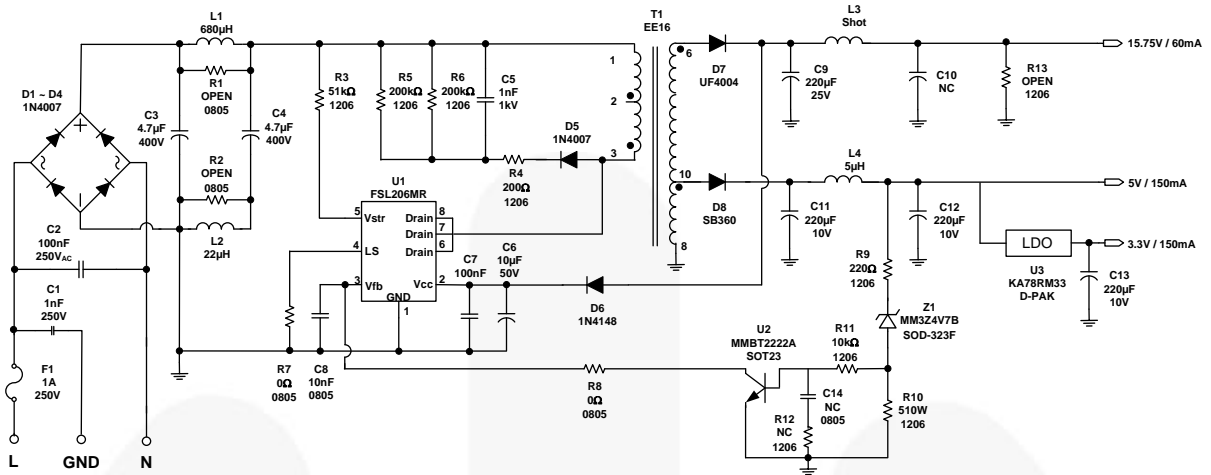


Figure 14. PS1 Schematic

**Note:**

- This power supply is significantly larger in power levels that is typically required in motor control applications. The increased output capacity of this supply is to support the testing and evaluation process and may be used to power select MCU development boards. See the output current limits in the Specification section.

## 6. PCB and Assembly Images

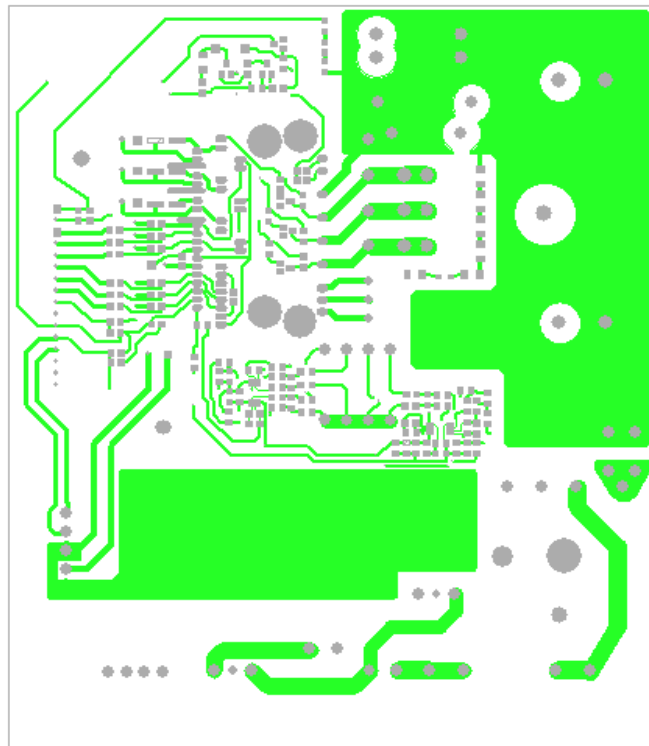


Figure 15. Top Layer

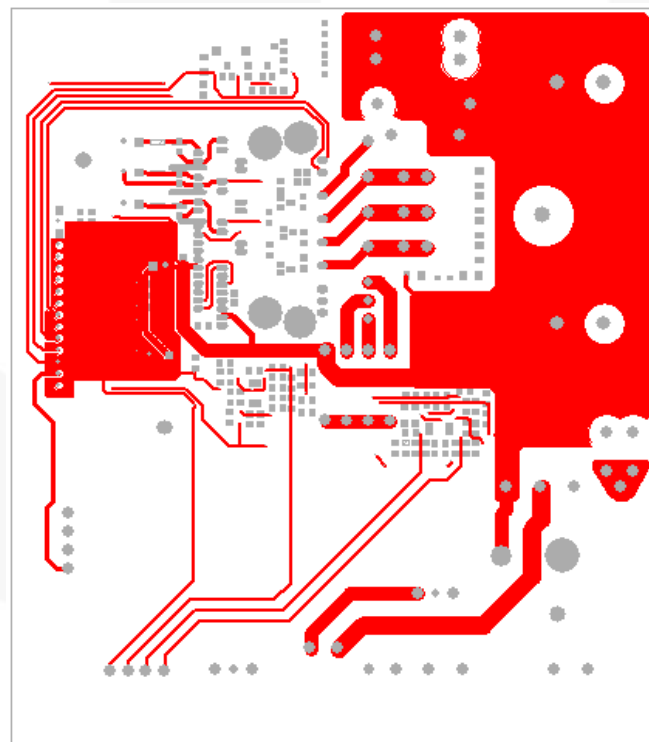


Figure 16. Bottom Layer

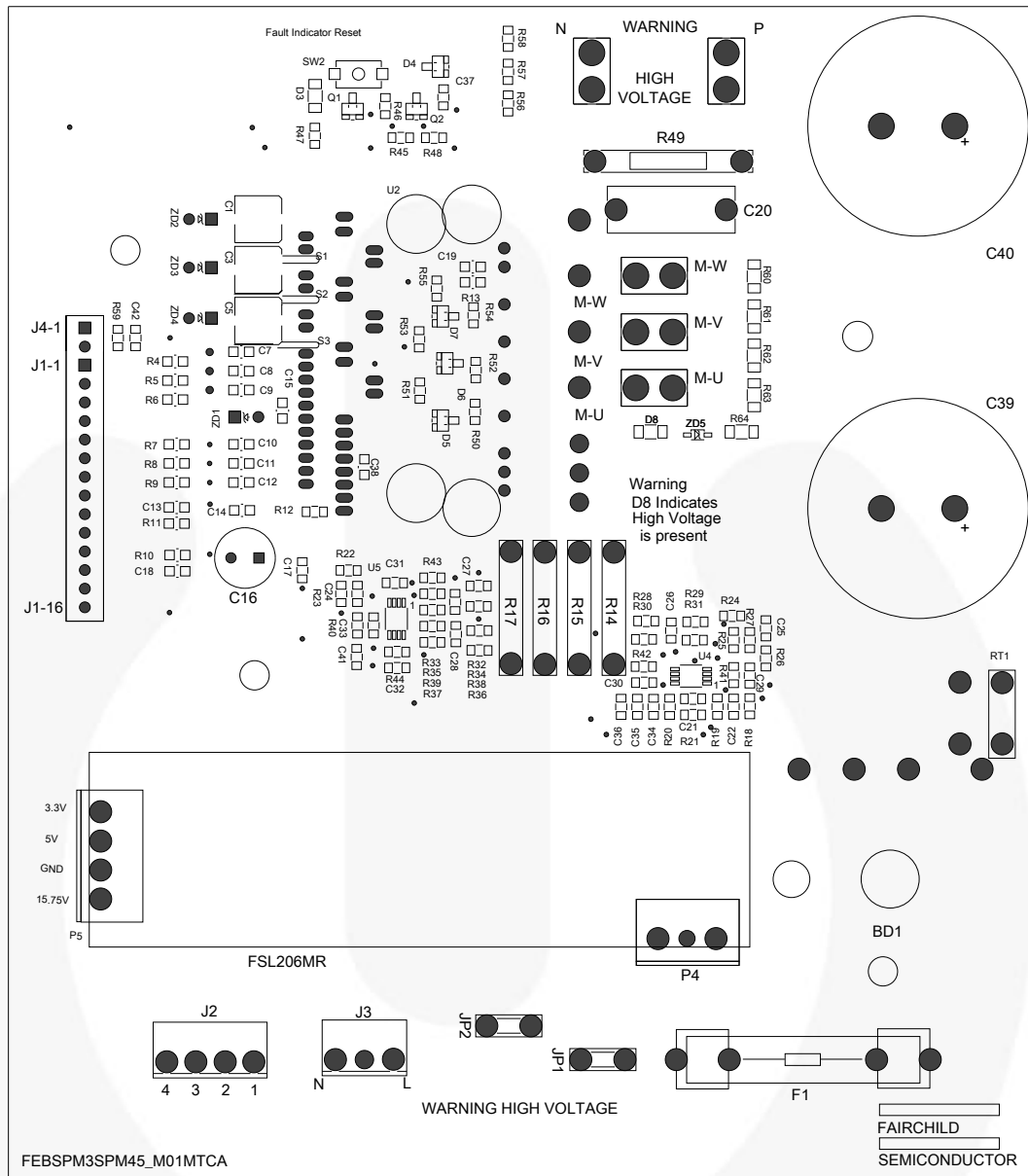
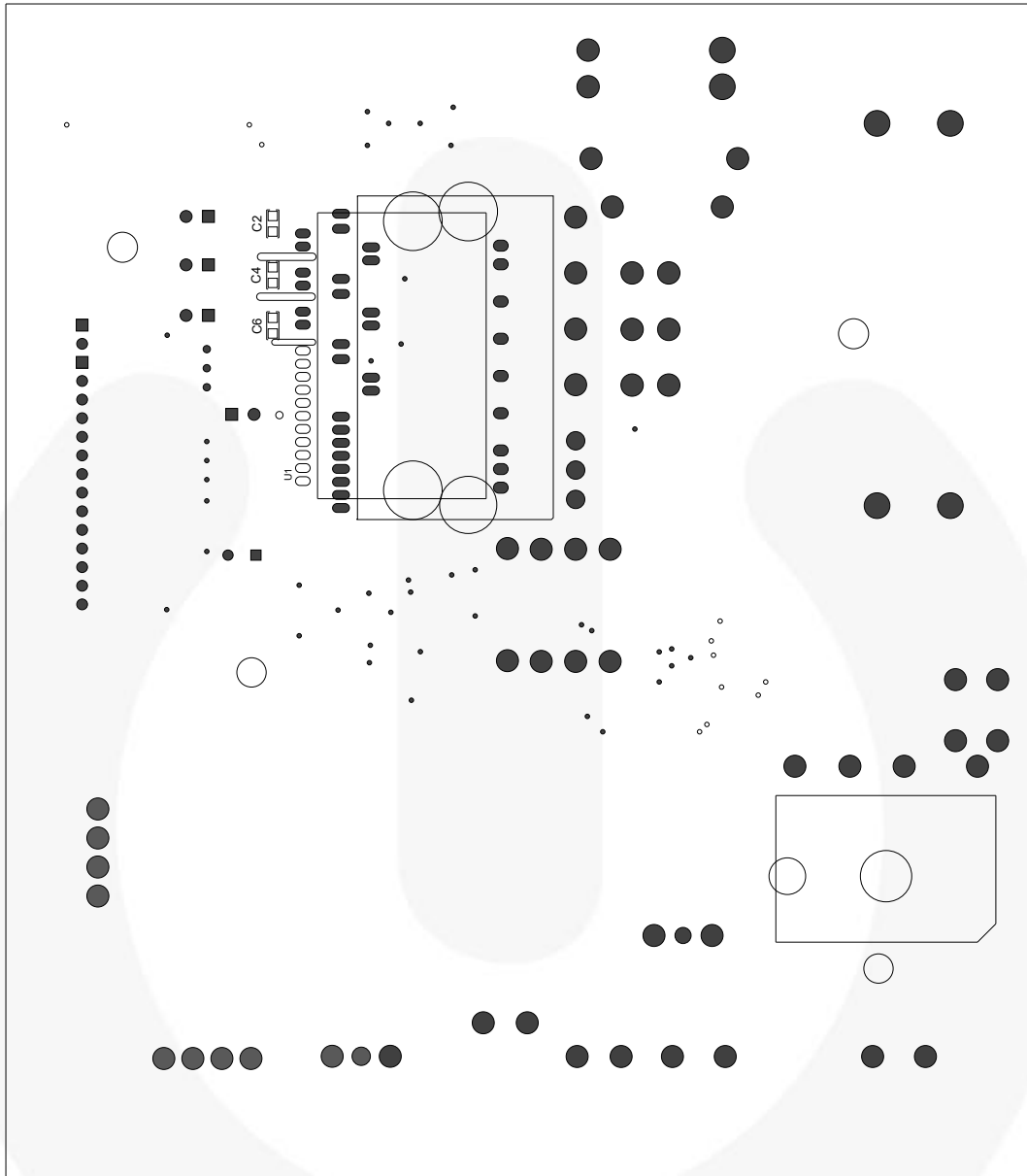


Figure 17. Top Assembly



**Figure 18. Bottom Assembly**

## 7. Bill of Materials

Item	Qty.	Reference	Part Number	Value	Description	Manufacturer	Package
1	1	BR1	DFB2560	25 A	600 V, Bridge Rectifier	Fairchild Semiconductor	Thru-Hole
2	3	C1, C3, C5	EEE-FK1V330P	33 $\mu$ F	Capacitor, SMD, Alum, 35 V	Panasonic - ECG	SMD
3	4	C2, C4, C6, C15	C0805C104K5RACTU	100 nF	Capacitor, SMD, Ceramic, 50 V	Kemet	805
4	1	C16	EKZE350ELL221MH15D	220 $\mu$ F	Capacitor, Alum, 35 V, Radial	United Chemi-Con	Thru-Hole
5	2	C17, C38	C0805C333K5RACTU	33 nF	Capacitor, Ceramic, 50 V, X7R	Kemet	805
6	2	C18, C41	GRM21BR71H105KA12L	1 $\mu$ F	Capacitor, Ceramic, 50 V, X7R	Murata	805
7	1	C20	ECQ-E6104KF	0.1 $\mu$ F	ECQ-E6104KF	Panasonic	Thru-Hole
8	14	C21, C22, C24, C25, C26, C27, C28, C29, C30, C31, C32, C33, C34, C35	C0805C101K5GACTU	100 pF	Capacitor, Ceramic, 50 V, X7R	Kemet	805
9	1	C37	C0805C104K4RACTU	0.1 $\mu$ F	Capacitor, Ceramic, 16 V, X7R	Kemet	805
10	2	C39, C40	EET-UQ2W681EA	680 $\mu$ F	Capacitor, Alum, 450 V, Radial	Panasonic	Thru-Hole
11	1	C42	C0805C153K5RACTU	15 nF	Capacitor, Ceramic, 50 V, X7R	Kemet	805
12	9	C7, C8, C9, C10, C11, C12, C13, C14, C19	C0805C102K5RACTU	1 nF	Capacitor, SMD, Ceramic, 25 V, X7R	STD	805
13	1	D3, D8	CMD15-21VRD/TR8		LED, 100V, 200 mA	Chicago Mini Light	1206
14	4	D4, D5, D6, D7	MMBD4148	1 $\mu$ F	Capacitor, SMD, Ceramic, 50 V, X5R	STD	SOT-23
15	1	F1	0326025.HXP	10 A	Fuse Cover .32x1.42x5"		
16	3	F1C	840836		Fuse Cover	Richco Plastic Co.	
17	2	F1CLP	BK/1A1907-05		Fuse Clip (6.35 mm)	Cooper Bussman	
18	1	J1	22-28-4163		Conn Header 16 Pin 0.1 Vert Gold	TE Connectivity	Thru-Hole
19	1	J2	09-65-2048		4 Pin Header 3.96 mm Pitch	Molex	Thru-Hole
20	1	J3	09-65-2038		3 Pin Header 3.96 mm Pitch	Molex	Thru-Hole
21	1	P4	09-50-1031		3 Pin rcpt 3.96 mm Pitch	Molex	Thru-Hole
22	1	P5	09-50-1041		4 Pin rcpt 3.96 mm Pitch	Molex	Thru-Hole
23	1	PS1	FSL206MR		15.75 V, 5 V, 3.3 V SMPS	Fairchild Semiconductor	
24	1	Q1	MMBT2222A		Transistor, NPN, 40 V, 1 A	Fairchild Semiconductor	SOT-23
25	1	Q2	MMBT2907A		Transistor, PNP, 60 V, 0.8 A	Fairchild Semiconductor	SOT-23
26	1	R10	MCR10EZPJ472	4.7 k $\Omega$	Resistor, 1/8 W, 5%	ROHM	805
27	1	R12	MCR10EZJH620	62 k $\Omega$	Resistor, 1/8 W, 5%	ROHM	805
28	1	R13	MCR10EZPF6801	6.8 k $\Omega$	Resistor, 1/8 W, 5%	ROHM	805

Item	Qty.	Reference	Part Number	Value	Description	Manufacturer	Package
29	4	R14, R15, R16, R17	BR3FB15L0 (Optional)	0.015 Ω	Resistor, 3 W, ±1%	Stackpole ELEC.	Thru-Hole
30	4	R14, R15, R16, R17	BR3FB10L0	0.010 Ω	Resistor, 3 W, ±1%	Stackpole ELEC.	Thru-Hole
31	6	R18, R19, R20, R21, R22, R23	MCR10EZPF7872	78 kΩ	Resistor, 1/8 W, 5%	ROHM	805
32	8	R24, R26, R28, R30, R32, R34, R36, R38	MCR10EZPF1001	1.0 kΩ	Resistor, 1/8 W, 5%	ROHM	805
33	8	R25, R27, R29, R31, R33, R35, R37, R39	MCR10EZPF1801	1.8 kΩ	Resistor, 1/8 W, 5%	ROHM	805
34	7	R4, R5, R6, R7, R8, R9, R11	MCR10EZPJ101	100 kΩ	Resistor, 1/8 W, 5%	ROHM	805
35	1	R40	MCR10EZPF8201	8.2 kΩ	Resistor, 1/8 W, 5%	ROHM	805
36	3	R41, R42, R43	MCR10EZHF3902	39 kΩ	Resistor, 1/8 W, 5%	ROHM	805
37	1	R44	MCR10EZPF7871	7.87 kΩ	Resistor, 1/8 W, 5%	ROHM	805
38	1	R45	MCR10EZPJ104	100 kΩ	Resistor, 1/8 W, 5%	ROHM	805
39	2	R46, R48	MCR10EZPJ332	3.3 kΩ	Resistor, 1/8 W, 5%	ROHM	805
40	1	R47	MCR10EZPJ331	330 kΩ	Resistor, 1/8 W, 5%	ROHM	805
41	1	R49		62 kΩ	Resistor, 1/8 W, 5%	ROHM	805
42	3	R56, R57, R58	MCR10EZHF5103	510 kΩ	Resistor, 1/8 W, 5%	ROHM	805
43	1	R59	MCR18EZPF2002	20 kΩ	Resistor, 1/8 W, 5%	ROHM	805
44	5	R60, R61, R62, R63, R64	MCR18EZPF2202	22 kΩ	Resistor, 1/8 W, 5%	ROHM	805
45	1	RT1	CL-11	12 A	Inrush current limiter, 0.02 Ω	GE Sensing	Thru-Hole
46	0	RT2	DNP				
47	1	SW1	KSR223GNCLFG		Switch Tactile, SPST, n/c, 32 V	C&K Components	SMD
48	5	U, V, W, P, N	63824-1		Tab Terminal		Thru-Hole
49	1	U1	FNB41560	NOTE8	SPM45H SPM	Fairchild Semiconductor	Thru-Hole
50	2	U4, U5	FAN4274IMU8X		Dual, Low Cost, RRIO CMOS Amp	Fairchild Semiconductor	MSOP 8-Lead
51	4	ZD1, ZD2, ZD3, ZD4	1N4749ATR	24 V	ZD1,ZD2,ZD3,ZD4	Fairchild Semiconductor	DO-41
52	1	ZD5	MM3Z47VB	47 V	Diode, Zener, 200 mW	Fairchild Semiconductor	SOD-323F

**Notes:**

7. DNP = Do Not Populate.
8. U1 replaceable, depending on design requirements.

## 8. Key Parameter Design

### 8.1. Current-Sensing Circuit

To simplify current-sensing circuit design, this evaluation board has open-emitter DC-link terminals ( $N_U$ ,  $N_V$ ,  $N_W$ ) for current sensing. Refer to reference design [RD-344](#) for a more detailed explanation. In this example, the ideal sense resistor value is 8 m $\Omega$ . The board includes a default sense resistor of 10 m $\Omega$ . The actual sense resistor value used is typically a balance between noise-levels at small currents and sense-resistor losses.

#### Calculation Conditions

- Installed SPM: FNB41560
- Op Amp: FAN4274
- Resistance of Sense Resistor: 8 m $\Omega$ ,  $\pm 1\%$
- Voltage Gain: 13.9
- Bandwidth: 86 kHz
- Refer to Figure 15

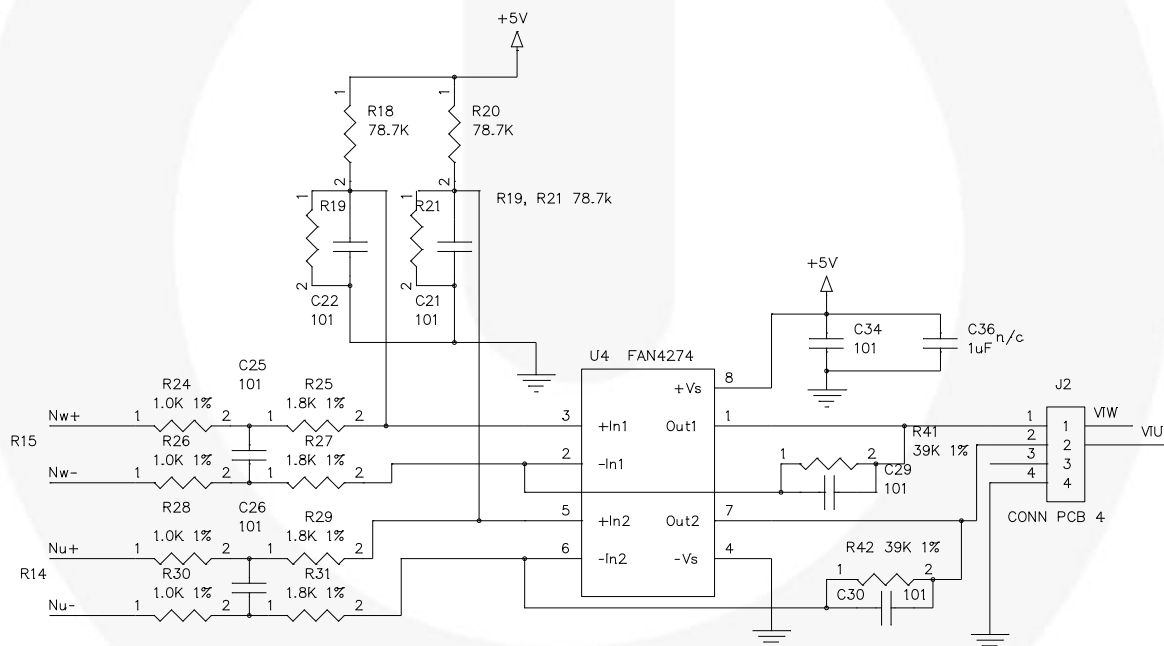


Figure 19. Current-Sensing Circuit



## 8.2. Short-Circuit Protection (SCP) Circuit

One shunt resistor is used for sensing short-circuit (SC) current. The related circuit is composed of an external shunt resistor, op amp, RC low-pass filter, fault indicator circuit, and fault output pin. Refer to reference design [RD-344](#) for a more detailed explanation of the SCP circuit shown in Figure 16. In this example, the ideal shunt resistor value is 8 mΩ. The default shunt resistor used on this board is a 10 mΩ. The actual shunt resistor value used is typically a balance between component count (if op amp is required due to small resistor value) and shunt-resistor losses.

During a short-circuit condition, the SPM VFO pin is actively pulled down via the internal open-collector transistor. This event lights the fault indicator LED (D3) and sends the low FO signal to the MCU via J1-9. To reset fault and its indicator D3, press fault-reset switch SW2.

### Calculation Conditions

- Installed SPM: FNB41560
- Op Amp: FAN4274
- Resistance of Shunt Resistor: 8 mΩ, ±1 %
- SC Trip Current: 22.5 A (1.5 x I<sub>C</sub> (rated current), can be lowered by the designer)
- SC Trip Reference Voltage: V<sub>SC(min)</sub>=0.45 V, v<sub>SC(typ)</sub>=0.5 V, V<sub>SC(max)</sub>=0.55 V
- Refer to Figure 16
- Alternatively, a larger value shunt resistor could be used without requiring an op amp at the expense of higher losses in the sense resistor.

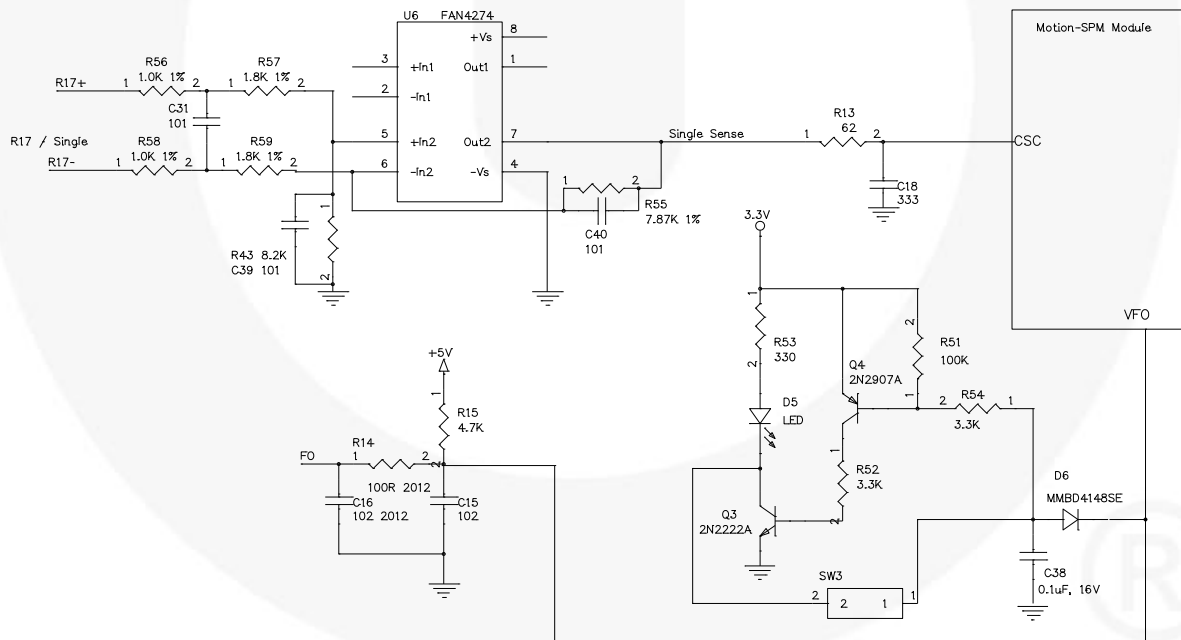


Figure 20. Short-Circuit Protection Circuit

## 9. $V_{BUS}$ Sense Circuit

This evaluation board is equipped with a  $V_{BUS}$  sense output. As seen in Figure 18, the voltage divider network is in parallel with bulk capacitors C39 and C40. With a  $V_{BUS}$  of 300  $V_{DC}$ , a nominal output of  $\sim 3.9 V_{DC}$  is typical at J4-1.

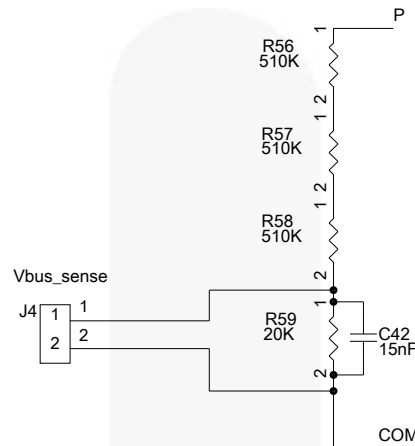


Figure 21.  $V_{BUS}$  Sense Circuit

## 10. Test Waveforms

### 10.1. Bulk Capacitor Ripple Current

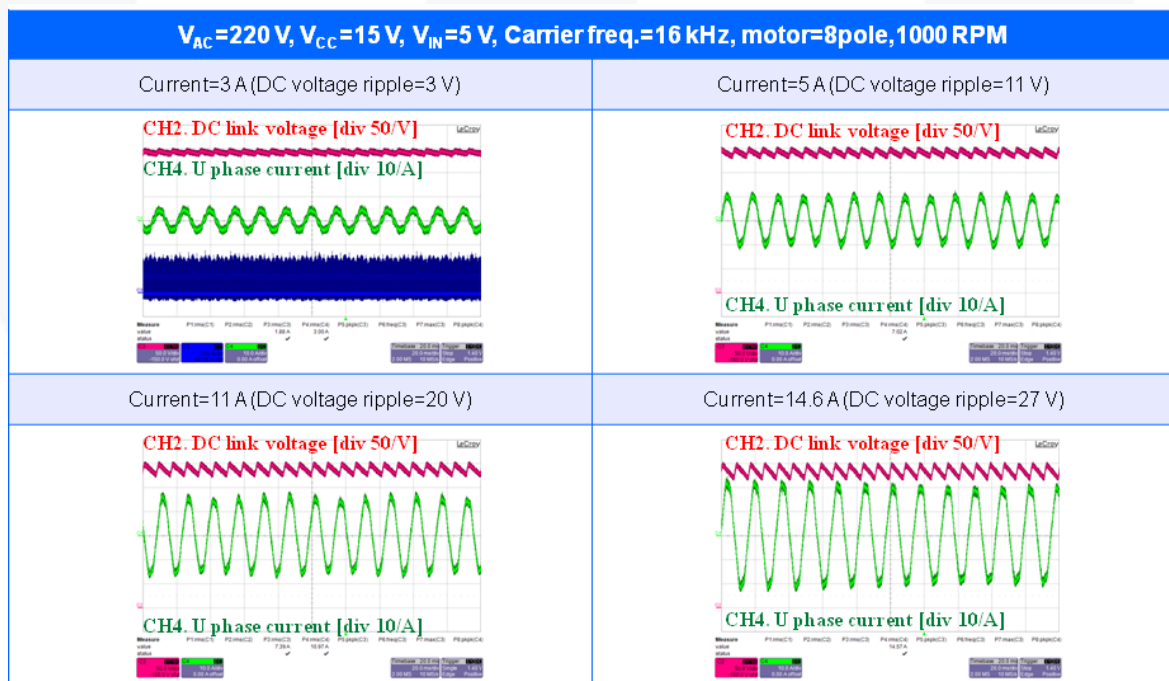


Figure 22. Bulk Capacitor Ripple Voltage Under Varying Load Currents

## 10.2. NTC Temperature

RT1 operating temperature measured at varying load currents.

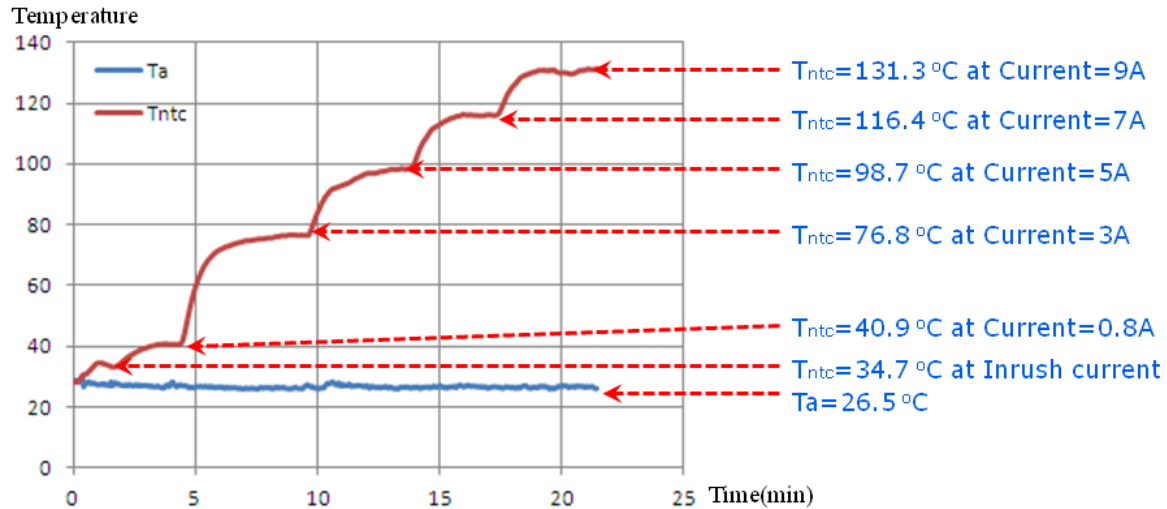


Figure 23. NTC Temperature

## 11. References

- [RD-344: Fairchild Motion-SPM FNA41560 – Three Shunt Design](#)
- [RD-345: Fairchild Motion-SPM FNA41560 – Single Shunt Design](#)
- [AN-9021: A Novel IGBT Inverter Module for Low-Power Drive Applications](#)
- [AN-9035: Smart Power Module Motion-SPM in Mini-DIP User's Guide](#)
- [AN-9041: PFCM Design Guide with Analog PFC IC](#)
- [AN-9042: Smart Power Module Tiny-DIP SPM® User's Guide](#)
- [AN-9043: Smart Power Module DIP SPM® User's Guide](#)
- [AN-9044: Smart Power Module Motion SPM® in Mini DIP SPM®](#)
- [AN-9070: Smart Power Module Motion SPM® in SPM45H](#)
- [AN-9071: Smart Power Module Motion SPM® in SPM45H Thermal Performance Information](#)
- [AN-9072: Smart Power Module Motion SPM® in SPM45H Mounting Guidance](#)

## 12. Revision History

Date	Revision	Description
January 2013	1.0.0	Initial Release
April 2013	1.0.1	Add output voltage specification to Table 1 Evaluation Board, list U1 in BOM

---

### WARNING AND DISCLAIMER

Replace components on the Evaluation Board only with those parts shown on the parts list (or Bill of Materials) in the Users' Guide. Contact an authorized Fairchild representative with any questions.

This board is intended to be used by certified professionals, in a lab environment, following proper safety procedures. Use at your own risk. The Evaluation board (or kit) is for demonstration purposes only and neither the Board nor this User's Guide constitute a sales contract or create any kind of warranty, whether express or implied, as to the applications or products involved. Fairchild warrants that its products meet Fairchild's published specifications, but does not guarantee that its products work in any specific application. Fairchild reserves the right to make changes without notice to any products described herein to improve reliability, function, or design. Either the applicable sales contract signed by Fairchild and Buyer or, if no contract exists, Fairchild's standard Terms and Conditions on the back of Fairchild invoices, govern the terms of sale of the products described herein.

#### DISCLAIMER

FAIRCHILD SEMICONDUCTOR RESERVES THE RIGHT TO MAKE CHANGES WITHOUT FURTHER NOTICE TO ANY PRODUCTS HEREIN TO IMPROVE RELIABILITY, FUNCTION, OR DESIGN. FAIRCHILD DOES NOT ASSUME ANY LIABILITY ARISING OUT OF THE APPLICATION OR USE OF ANY PRODUCT OR CIRCUIT DESCRIBED HEREIN; NEITHER DOES IT CONVEY ANY LICENSE UNDER ITS PATENT RIGHTS, NOR THE RIGHTS OF OTHERS.

#### LIFE SUPPORT POLICY

FAIRCHILD'S PRODUCTS ARE NOT AUTHORIZED FOR USE AS CRITICAL COMPONENTS IN LIFE SUPPORT DEVICES OR SYSTEMS WITHOUT THE EXPRESS WRITTEN APPROVAL OF THE PRESIDENT OF FAIRCHILD SEMICONDUCTOR CORPORATION.

As used herein:

1. Life support devices or systems are devices or systems which, (a) are intended for surgical implant into the body, or (b) support or sustain life, or (c) whose failure to perform when properly used in accordance with instructions for use provided in the labeling, can be reasonably expected to result in significant injury to the user.
2. A critical component is any component of a life support device or system whose failure to perform can be reasonably expected to cause the failure of the life support device or system, or to affect its safety or effectiveness

---

### ANTI-COUNTERFEITING POLICY

Fairchild Semiconductor Corporation's Anti-Counterfeiting Policy. Fairchild's Anti-Counterfeiting Policy is also stated on our external website, [www.fairchildsemi.com](http://www.fairchildsemi.com), under Sales Support.

Counterfeiting of semiconductor parts is a growing problem in the industry. All manufacturers of semiconductor products are experiencing counterfeiting of their parts. Customers who inadvertently purchase counterfeit parts experience many problems such as loss of brand reputation, substandard performance, failed applications, and increased cost of production and manufacturing delays. Fairchild is taking strong measures to protect ourselves and our customers from the proliferation of counterfeit parts. Fairchild strongly encourages customers to purchase Fairchild parts either directly from Fairchild or from Authorized Fairchild Distributors who are listed by country on our web page cited above. Products customers buy either from Fairchild directly or from Authorized Fairchild Distributors are genuine parts, have full traceability, meet Fairchild's quality standards for handling and storage and provide access to Fairchild's full range of up-to-date technical and product information. Fairchild and our Authorized Distributors will stand behind all warranties and will appropriately address any warranty issues that may arise. Fairchild will not provide any warranty coverage or other assistance for parts bought from Unauthorized Sources. Fairchild is committed to combat this global problem and encourage our customers to do their part in stopping this practice by buying direct or from authorized distributors.

---

### EXPORT COMPLIANCE STATEMENT

These commodities, technology, or software were exported from the United States in accordance with the Export Administration Regulations for the ultimate destination listed on the commercial invoice. Diversion contrary to U.S. law is prohibited.

U.S. origin products and products made with U.S. origin technology are subject to U.S. Re-export laws. In the event of re-export, the user will be responsible to ensure the appropriate U.S. export regulations are followed.