

Micro MINI S1C60N08/60R08

4-bit Single Chip Microcomputer



- S1C6200C Core CPU
- Built-in LCD Driver
- Serial Interface

DESCRIPTION

The S1C60N08 Series is a single-chip microcomputer made up of the 4-bit core CPU S1C6200C, ROM (4,096 words × 12 bits), RAM (832 words × 4 bits), LCD driver, serial interface, event counter with dial input function, watchdog timer, and two types of time base counter. Because of its low-voltage operation and low power consumption, this series is ideal for a wide range of applications, and is especially suitable for battery-driven systems.

The S1C60R08 is a microcomputer with a CMOS 4-bit core CPU S1C6200C as main component, and a built-in programmable RAM (ROM emulator). The S1C60R08 has almost the same functions as the S1C60N08/60A08. The mask ROM in the S1C60N08/60A08 has been changed to a ROM emulator that allows the user to rewrite programs using a Serial EEPROM.

CONFIGURATION

The S1C60N08 Series is configured as follows, depending on supply voltage and oscillation circuits.

Model	S1C60N08	S1C60A08	S1C60L08
Supply voltage	3.0 V	3.0 V	1.5 V
Oscillation circuit	OSC1 only (Single clock)	OSC1 and OSC3 (Twin clock)	OSC1 only (Single clock)
Evaluation tool	S1C60R08		-

FEATURES

- OSC1 oscillation circuit Crystal oscillation circuit 32.768 kHz (Typ.)/38.400 kHz (Typ.)
- OSC3 oscillation circuit CR or ceramic oscillation circuit (*1) 500 kHz (Typ.)
...S1C60A08/60R08 only
- Instruction set 108 types
- Instruction execution time CLK = 32.768 kHz: 153 μsec, 214 μsec, 366 μsec
(differs depending on instruction) CLK = 38.400 kHz: 130 μsec, 182 μsec, 313 μsec
(CLK: CPU operation frequency) CLK = 500 kHz: 10 μsec, 14 μsec, 24 μsec...S1C60A08/60R08 only
- ROM capacity 4,096 words × 12 bits
- Serial EEPROM interface Built-in (Microchip 24AA65 two wire bus protocol interfaces)
...S1C60R08 only
- RAM capacity 832 words × 4 bits
- Input ports 9 bits (pull-down resistor can be added *1)
- Output ports 8 bits (BZ, \overline{BZ} , FOUT and SIOF outputs are available *1)
- I/O ports 8 bits (pull-down resistor is added during input data read-out)
- Serial interface 1 port (8-bit clock synchronous system)
- LCD driver 48 segments × 4, 3, or 2 commons (*1)
V-3 V 1/4, 1/3 or 1/2 duty (voltage regulator and booster circuits built-in)
- Time base counter Two types (timer and stopwatch)
- Watchdog timer Built-in (*1)

S1C60N08/60R08

- Event counter Two 8-bit inputs (dial input evaluation or independent)
- Sound generator Programmable in 8 sounds (8 frequencies)
Digital envelope built-in (*1)
- Analog comparator Inverted input × 1, non-inverted input × 1
- Battery low detection circuit (BLD) .. Dual system (programmable in 8 values and a fixed value)
2.4 V, 2.2–2.55 V ...**S1C60N08/60A08/60R08**
1.2 V, 1.05–1.4 V ...**S1C60L08**
- External interrupt Input interrupt: 3 systems
- Internal interrupt Time base counter interrupt: 2 systems
Serial interface interrupt: 1 system
- Supply voltage 3.0 V (1.8–3.5 V) ...**S1C60N08/60A08/60R08**
1.5 V (0.9–1.7 V) ...**S1C60L08**
- Current consumption **S1C60N08**
Halt state: 1.0 μA when CLK = 32.768 kHz (Typ.)
Run state: 2.2 μA when CLK = 32.768 kHz (Typ.)
S1C60L08
Halt state: 1.0 μA when CLK = 32.768 kHz (Typ.)
Run state: 2.2 μA when CLK = 32.768 kHz (Typ.)
S1C60A08
Halt state: 1.1 μA when CLK = 32.768 kHz (Typ.)
Run state: 3.0 μA when CLK = 32.768 kHz (Typ.)
Run state: 50 μA when CLK = 500 kHz (Typ.)
S1C60R08
Halt state: 1.0 μA when CLK = 32.768 kHz (Typ.)...Target for **S1C60N08**
1.1 μA when CLK = 32.768 kHz (Typ.)...Target for **S1C60A08**
Run state: 6.5 μA when CLK = 32.768 kHz (Typ.)...Target for **S1C60N08**
7.5 μA when CLK = 32.768 kHz (Typ.)...Target for **S1C60A08**
Run state: 115 μA when CLK = 500 kHz (Typ.)...Target for **S1C60A08** only
- Package QFP5-100pin, QFP15-100pin (plastic) or chip
*1: Can be selected with mask option

■ BLOCK DIAGRAM

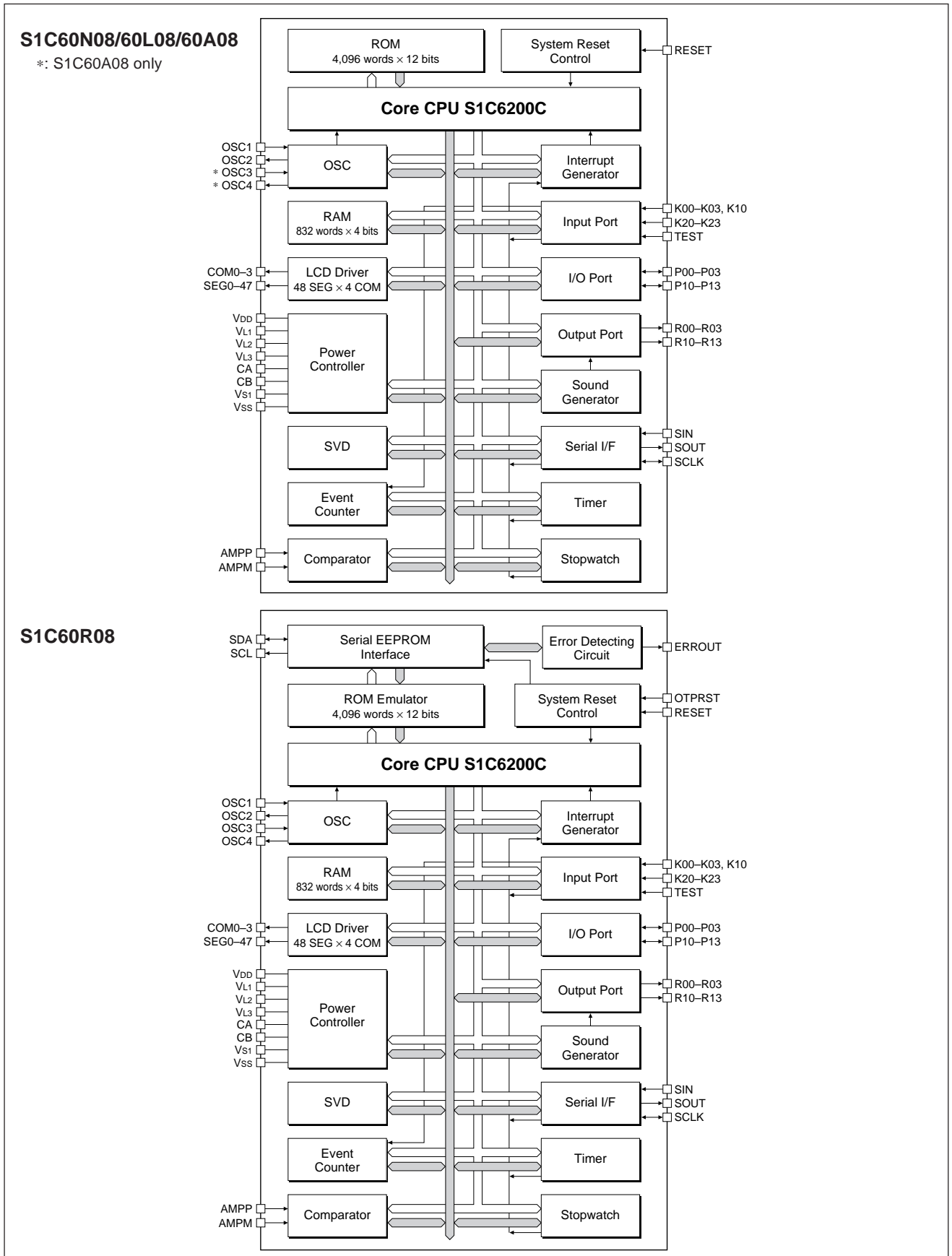

S1C60N08/60R08

■ PIN CONFIGURATION

● S1C60N08/60L08/60A08 Pin Configuration

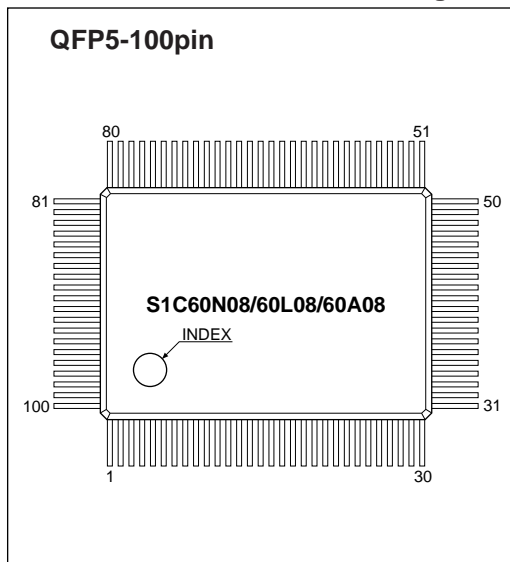

No.	Pin name	No.	Pin name	No.	Pin name	No.	Pin name	No.	Pin name
1	COM1	21	SEG29	41	SEG10	61	K01	81	R12
2	COM0	22	SEG28	42	SEG9	62	K00	82	R11
3	SEG47	23	SEG27	43	SEG8	63	SIN	83	R10
4	SEG46	24	SEG26	44	SEG7	64	SOUT	84	R13
5	SEG45	25	SEG25	45	SEG6	65	N.C.	85	V _{SS}
6	SEG44	26	SEG24	46	SEG5	66	SCLK	86	RESET
7	SEG43	27	TEST	47	SEG4	67	P03	87	OSC4
8	SEG42	28	SEG23	48	SEG3	68	P02	88	OSC3
9	SEG41	29	SEG22	49	SEG2	69	P01	89	V _{S1}
10	SEG40	30	SEG21	50	SEG1	70	P00	90	OSC2
11	SEG39	31	SEG20	51	SEG0	71	N.C.	91	OSC1
12	SEG38	32	SEG19	52	AMPP	72	N.C.	92	V _{DD}
13	SEG37	33	SEG18	53	AMPM	73	P13	93	V _{L3}
14	SEG36	34	SEG17	54	K23	74	P12	94	V _{L2}
15	SEG35	35	SEG16	55	K22	75	P11	95	V _{L1}
16	SEG34	36	SEG15	56	K21	76	P10	96	CA
17	SEG33	37	SEG14	57	K20	77	R03	97	CB
18	SEG32	38	SEG13	58	K10	78	R02	98	N.C.
19	SEG31	39	SEG12	59	K03	79	R01	99	COM3
20	SEG30	40	SEG11	60	K02	80	R00	100	COM2

N.C. = No Connection

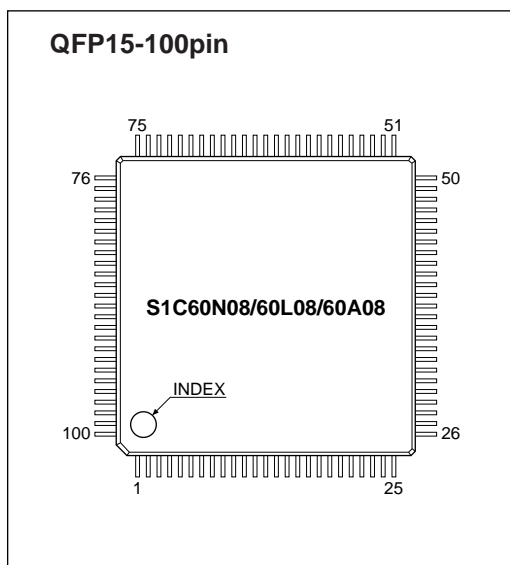

No.	Pin name	No.	Pin name	No.	Pin name	No.	Pin name	No.	Pin name
1	SEG47	21	SEG27	41	SEG9	61	K00	81	R10
2	SEG46	22	SEG26	42	SEG8	62	SIN	82	R13
3	SEG45	23	SEG25	43	SEG7	63	SOUT	83	V _{SS}
4	SEG44	24	SEG24	44	SEG6	64	N.C.	84	RESET
5	SEG43	25	TEST	45	SEG5	65	SCLK	85	OSC4
6	SEG42	26	SEG23	46	SEG4	66	N.C.	86	OSC3
7	SEG41	27	SEG22	47	SEG3	67	P03	87	V _{S1}
8	SEG40	28	SEG21	48	SEG2	68	P02	88	OSC2
9	SEG39	29	SEG20	49	SEG1	69	P01	89	OSC1
10	SEG38	30	SEG19	50	SEG0	70	P00	90	V _{DD}
11	SEG37	31	SEG18	51	AMPP	71	P13	91	V _{L3}
12	SEG36	32	SEG17	52	AMPM	72	P12	92	V _{L2}
13	SEG35	33	SEG16	53	K23	73	P11	93	V _{L1}
14	SEG34	34	SEG15	54	K22	74	P10	94	CA
15	SEG33	35	SEG14	55	K21	75	R03	95	CB
16	SEG32	36	SEG13	56	K20	76	R02	96	N.C.
17	SEG31	37	SEG12	57	K10	77	R01	97	COM3
18	SEG30	38	N.C.	58	K03	78	R00	98	COM2
19	SEG29	39	SEG11	59	K02	79	R12	99	COM1
20	SEG28	40	SEG10	60	K01	80	R11	100	COM0

N.C. = No Connection

● S1C60N08/60L08/60A08 Pin Description

Pin name	Pin No.		I/O	Function
	QFP5-100	QFP15-100		
VDD	92	90	(I)	Power supply pin (+)
VSS	85	83	(I)	Power supply pin (-)
VS1	89	87	-	Oscillation and internal logic system voltage output pin
VL1	95	93	-	LCD drive voltage output pin (approx. -1.05 V or 1/2·VL2)
VL2	94	92	-	LCD drive voltage output pin (2·VL1 or approx. -2.10 V)
VL3	93	91	-	LCD drive voltage output pin (3·VL1 or 3/2·VL2)
CA, CB	96, 97	94, 95	-	Boost capacitor connecting pin
OSC1	91	89	I	Crystal oscillation input pin
OSC2	90	88	O	Crystal oscillation output pin
OSC3	88	86	I	CR or ceramic oscillation input pin * (N.C. for S1C60N08 and S1C60L08)
OSC4	87	85	O	CR or ceramic oscillation output pin * (N.C. for S1C60N08 and S1C60L08)
K00-K03	62-59	61-58	I	Input port pin
K10	58	57	I	Input port pin
K20-K23	57-54	56-53	I	Input port pin
P00-P03	70-67	70-67	I/O	I/O port pin
P10-P13	76-73	74-71	I/O	I/O port pin
R00-R03	80-77	78-75	O	Output port pin
R10	83	81	O	Output port pin or BZ output pin *
R13	84	82	O	Output port pin or BZ output pin *
R11	82	80	O	Output port pin or SIOF output pin *
R12	81	79	O	Output port pin or FOUT output pin *
SIN	63	62	I	Serial interface data input pin
SOUT	64	63	O	Serial interface data output pin
SCLK	66	65	I/O	Serial interface clock input/output pin
AMPP	52	51	I	Analog comparator non-inverted input pin
AMPM	53	52	I	Analog comparator inverted input pin
SEG0-47	51-28, 26-3	50-39, 37-26, 24-1	O	LCD segment output pin or DC output pin *
COM0-3	2, 1, 100, 99	100-97	O	LCD common output pin (1/2, 1/3 or 1/4 duty are selectable *)
RESET	86	84	I	Initial reset input pin
TEST	27	25	I	Input pin for test

* Can be selected by mask option

S1C60N08/60R08

● S1C60R08 Pin Configuration

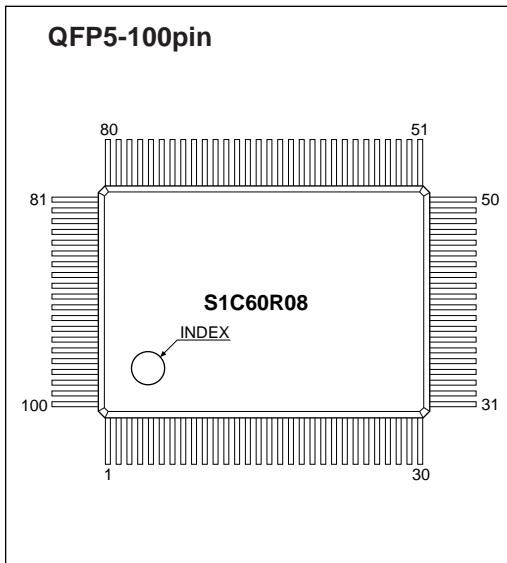

No.	Pin name	No.	Pin name	No.	Pin name	No.	Pin name	No.	Pin name
1	COM1	21	SEG29	41	SEG10	61	K01	81	R12
2	COM0	22	SEG28	42	SEG9	62	K00	82	R11
3	SEG47	23	SEG27	43	SEG8	63	SIN	83	R10
4	SEG46	24	SEG26	44	SEG7	64	SOUT	84	R13
5	SEG45	25	SEG25	45	SEG6	65	OTPRST	85	Vss
6	SEG44	26	SEG24	46	SEG5	66	SCLK	86	RESET
7	SEG43	27	TEST	47	SEG4	67	P03	87	OSC4
8	SEG42	28	SEG23	48	SEG3	68	P02	88	OSC3
9	SEG41	29	SEG22	49	SEG2	69	P01	89	Vs1
10	SEG40	30	SEG21	50	SEG1	70	P00	90	OSC2
11	SEG39	31	SEG20	51	SEG0	71	SCL	91	OSC1
12	SEG38	32	SEG19	52	AMPP	72	SDA	92	VDD
13	SEG37	33	SEG18	53	AMPM	73	P13	93	VL3
14	SEG36	34	SEG17	54	K23	74	P12	94	VL2
15	SEG35	35	SEG16	55	K22	75	P11	95	VL1
16	SEG34	36	SEG15	56	K21	76	P10	96	CA
17	SEG33	37	SEG14	57	K20	77	R03	97	CB
18	SEG32	38	SEG13	58	K10	78	R02	98	ERROUT
19	SEG31	39	SEG12	59	K03	79	R01	99	COM3
20	SEG30	40	SEG11	60	K02	80	R00	100	COM2

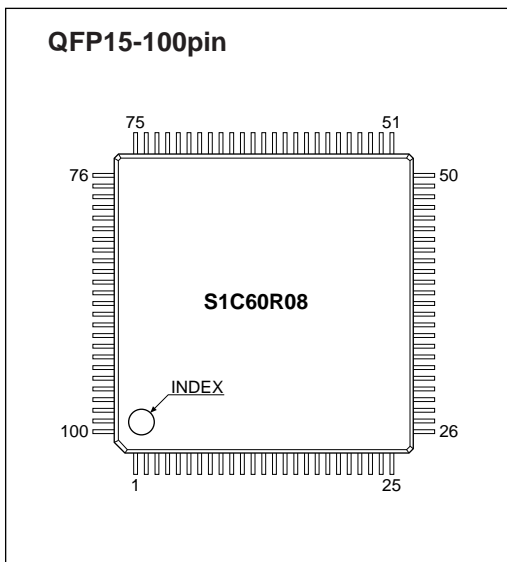

No.	Pin name	No.	Pin name	No.	Pin name	No.	Pin name	No.	Pin name
1	SEG47	21	SEG27	41	SEG8	61	SIN	81	R10
2	SEG46	22	SEG26	42	SEG7	62	SOUT	82	R13
3	SEG45	23	SEG25	43	SEG6	63	OTPRST	83	Vss
4	SEG44	24	SEG24	44	SEG5	64	SCLK	84	RESET
5	SEG43	25	TEST	45	SEG4	65	P03	85	OSC4
6	SEG42	26	SEG23	46	SEG3	66	P02	86	OSC3
7	SEG41	27	SEG22	47	SEG2	67	P01	87	Vs1
8	SEG40	28	SEG21	48	SEG1	68	P00	88	OSC2
9	SEG39	29	SEG20	49	SEG0	69	SCL	89	OSC1
10	SEG38	30	SEG19	50	AMPP	70	SDA	90	VDD
11	SEG37	31	SEG18	51	AMPM	71	P13	91	VL3
12	SEG36	32	SEG17	52	K23	72	P12	92	VL2
13	SEG35	33	SEG16	53	K22	73	P11	93	VL1
14	SEG34	34	SEG15	54	K21	74	P10	94	CA
15	SEG33	35	SEG14	55	K20	75	R03	95	CB
16	SEG32	36	SEG13	56	K10	76	R02	96	ERROUT
17	SEG31	37	SEG12	57	K03	77	R01	97	COM3
18	SEG30	38	SEG11	58	K02	78	R00	98	COM2
19	SEG29	39	SEG10	59	K01	79	R12	99	COM1
20	SEG28	40	SEG9	60	K00	80	R11	100	COM0

● S1C60R08 Pin Description

Pin name	Pin No.		I/O	Function
	QFP5-100	QFP15-100		
V _{DD}	92	90	(I)	Power supply pin (+)
V _{SS}	85	83	(I)	Power supply pin (-)
V _{S1}	89	87	–	Oscillation and internal logic system voltage output pin
V _{L1}	95	93	–	LCD drive voltage output pin (approx. -1.05 V or 1/2·V _{L2})
V _{L2}	94	92	–	LCD drive voltage output pin (2·V _{L1} or approx. -2.10 V)
V _{L3}	93	91	–	LCD drive voltage output pin (3·V _{L1} or 3/2·V _{L2})
CA, CB	96, 97	94, 95	–	Boost capacitor connecting pin
OSC1	91	89	I	Crystal oscillation input pin
OSC2	90	88	O	Crystal oscillation output pin
OSC3	88	86	I	CR or ceramic oscillation input pin *
OSC4	87	85	O	CR or ceramic oscillation output pin *
K00–K03	62–59	60–57	I	Input port pin
K10	58	56	I	Input port pin
K20–K23	57–54	55–52	I	Input port pin
P00–P03	70–67	68–65	I/O	I/O port pin
P10–P13	76–73	74–71	I/O	I/O port pin
R00–R03	80–77	78–75	O	Output port pin
R10	83	81	O	Output port pin or BZ output pin *
R11	82	80	O	Output port pin or SIOF output pin *
R12	81	79	O	Output port pin or FOUT output pin *
R13	84	82	O	Output port pin or $\overline{\text{BZ}}$ output pin *
SIN	63	61	I	Serial interface data input pin
SOUT	64	62	O	Serial interface data output pin
SCLK	66	64	I/O	Serial interface clock input/output pin
AMPP	52	50	I	Analog comparator non-inverted input pin
AMPM	53	51	I	Analog comparator inverted input pin
SEG0–47	51–28, 26–3	49–26, 24–1	O	LCD segment output pin or DC output pin *
COM0–3	2, 1, 100, 99	100–97	O	LCD common output pin (1/2, 1/3 or 1/4 duty are selectable *)
RESET	86	84	I	Initial reset input pin
TEST	27	25	I	Input pin for test
SCL	71	69	O	Serial EEPROM clock output pin
SDA	72	70	I/O	Serial EEPROM data input/output pin
ERROUT	98	96	O	Error detecting signal output for download program
OTPRST	65	63	I	Cold reset pin for re-start download program from EEPROM

* Can be selected by mask option

S1C60N08/60R08

■ OPTION LIST

1. DEVICE TYPE		
• DEVICE TYPE	<input type="checkbox"/> 1. S1C60N08 (Normal Type)	
	<input type="checkbox"/> 2. S1C60L08 (Low Power Type) (Note)	
	<input type="checkbox"/> 3. S1C60A08 (Twin Clock Type)	
• CLOCK TYPE (for Evaluation board)	<input type="checkbox"/> 1. 32 kHz	<input type="checkbox"/> 2. 38 kHz
2. OSC3 SYSTEM CLOCK (only for S1C60A08)		
	<input type="checkbox"/> 1. CR	<input type="checkbox"/> 2. Ceramic
3. MULTIPLE KEY ENTRY RESET		
• COMBINATION	<input type="checkbox"/> 1. Not Use	
	<input type="checkbox"/> 2. Use K00, K01	
	<input type="checkbox"/> 3. Use K00, K01, K02	
	<input type="checkbox"/> 4. Use K00, K01, K02, K03	
• TIME AUTHORIZE	<input type="checkbox"/> 1. Use	<input type="checkbox"/> 2. Not Use
4. WATCHDOG TIMER		
	<input type="checkbox"/> 1. Use	<input type="checkbox"/> 2. Not Use
5. INPUT INTERRUPT NOISE REJECTOR		
• K00–K03	<input type="checkbox"/> 1. Use	<input type="checkbox"/> 2. Not Use
• K10	<input type="checkbox"/> 1. Use	<input type="checkbox"/> 2. Not Use
• K20–K23	<input type="checkbox"/> 1. Use	<input type="checkbox"/> 2. Not Use
6. INPUT PORT PULL DOWN RESISTOR		
• K00	<input type="checkbox"/> 1. With Resistor	<input type="checkbox"/> 2. Gate Direct
• K01	<input type="checkbox"/> 1. With Resistor	<input type="checkbox"/> 2. Gate Direct
• K02	<input type="checkbox"/> 1. With Resistor	<input type="checkbox"/> 2. Gate Direct
• K03	<input type="checkbox"/> 1. With Resistor	<input type="checkbox"/> 2. Gate Direct
• K10	<input type="checkbox"/> 1. With Resistor	<input type="checkbox"/> 2. Gate Direct
• K20	<input type="checkbox"/> 1. With Resistor	<input type="checkbox"/> 2. Gate Direct
• K21	<input type="checkbox"/> 1. With Resistor	<input type="checkbox"/> 2. Gate Direct
• K22	<input type="checkbox"/> 1. With Resistor	<input type="checkbox"/> 2. Gate Direct
• K23	<input type="checkbox"/> 1. With Resistor	<input type="checkbox"/> 2. Gate Direct
7. OUTPUT PORT SPECIFICATION (R00–R03)		
• R00	<input type="checkbox"/> 1. Complementary	<input type="checkbox"/> 2. Pch-OpenDrain
• R01	<input type="checkbox"/> 1. Complementary	<input type="checkbox"/> 2. Pch-OpenDrain
• R02	<input type="checkbox"/> 1. Complementary	<input type="checkbox"/> 2. Pch-OpenDrain
• R03	<input type="checkbox"/> 1. Complementary	<input type="checkbox"/> 2. Pch-OpenDrain
8. R10 SPECIFICATION		
• OUTPUT SPECIFICATION	<input type="checkbox"/> 1. Complementary	<input type="checkbox"/> 2. Pch-OpenDrain
• OUTPUT TYPE	<input type="checkbox"/> 1. DC Output	<input type="checkbox"/> 2. Buzzer Output
9. R11 SPECIFICATION		
• OUTPUT SPECIFICATION	<input type="checkbox"/> 1. Complementary	<input type="checkbox"/> 2. Pch-OpenDrain
• OUTPUT TYPE	<input type="checkbox"/> 1. DC Output	<input type="checkbox"/> 2. SIO Flag
10. R12 SPECIFICATION		
• OUTPUT SPECIFICATION	<input type="checkbox"/> 1. Complementary	<input type="checkbox"/> 2. Pch-OpenDrain
• OUTPUT TYPE	<input type="checkbox"/> 1. DC Output	
	<input type="checkbox"/> 2. FOUT 32768 or 38400 [Hz]	
	<input type="checkbox"/> 3. FOUT 16384 or 19200 [Hz]	
	<input type="checkbox"/> 4. FOUT 8192 or 9600 [Hz]	
	<input type="checkbox"/> 5. FOUT 4096 or 4800 [Hz]	
	<input type="checkbox"/> 6. FOUT 2048 or 2400 [Hz]	
	<input type="checkbox"/> 7. FOUT 1024 or 1200 [Hz]	
	<input type="checkbox"/> 8. FOUT 512 or 600 [Hz]	
	<input type="checkbox"/> 9. FOUT 256 or 300 [Hz]	

11. R13 SPECIFICATION

- OUTPUT SPECIFICATION 1. Complementary 2. Pch-OpenDrain
- OUTPUT TYPE 1. DC Output
 2. Buzzer Inverted Output (R13 Control)
 3. Buzzer Inverted Output (R10 Control)

12. I/O PORT SPECIFICATION

- P00 1. Complementary 2. Pch-OpenDrain
- P01 1. Complementary 2. Pch-OpenDrain
- P02 1. Complementary 2. Pch-OpenDrain
- P03 1. Complementary 2. Pch-OpenDrain
- P10 1. Complementary 2. Pch-OpenDrain
- P11 1. Complementary 2. Pch-OpenDrain
- P12 1. Complementary 2. Pch-OpenDrain
- P13 1. Complementary 2. Pch-OpenDrain

13. SIN PULL DOWN RESISTOR

- 1. With Resistor 2. Gate Direct

14. SOUT SPECIFICATION

- 1. Complementary 2. Pch-OpenDrain

15. SCLK SPECIFICATION

- PULL DOWN RESISTOR 1. With Resistor 2. Gate Direct
- OUTPUT SPECIFICATION 1. Complementary 2. Pch-OpenDrain
- LOGIC 1. Positive 2. Negative

16. SIO DATA PERMUTATION

- 1. MSB First 2. LSB First

17. EVENT COUNTER NOISE REJECTOR

- 1. 2048 or 2400 [Hz] 2. 256 or 300 [Hz]

18. LCD SPECIFICATION

• BIAS SELECTION

- S1C60N08 1. 1/3 Bias, Regulator Used, LCD 3 V
 2. 1/3 Bias, Regulator Not Used, LCD 3 V
 3. 1/2 Bias, Regulator Not Used, LCD 3 V
 4. 1/3 Bias, Regulator Not Used, LCD 4.5 V
- S1C60L08 (Note) 1. 1/3 Bias, Regulator Used, LCD 3 V
 2. 1/2 Bias, Regulator Not Used, LCD 3 V
 3. 1/3 Bias, Regulator Not Used, LCD 4.5 V
- S1C60A08 1. 1/3 Bias, Regulator Used, LCD 3 V
 2. 1/3 Bias, Regulator Not Used, LCD 3 V
 3. 1/2 Bias, Regulator Not Used, LCD 3 V
 4. 1/3 Bias, Regulator Not Used, LCD 4.5 V

• DUTY SELECTION

- 1. 1/4 Duty
- 2. 1/3 Duty
- 3. 1/2 Duty

19. SEGMENT MEMORY ADDRESS

- 1. 0 Page (040–06F) 2. 2 Page (240–26F)

Note: The S1C60R08 does not support the S1C60L08.

S1C60N08/60R08

■ S1C60R08 ROM EMULATOR/ROM EMULATOR PROGRAMMER

The S1C60R08 has a built-in ROM emulator, which is constructed by RAM, to emulate mask ROM. The ROM emulator is programmed from outside through the serial interface (programmer) circuit and then its data is read by the CPU. This chapter explain the ROM emulator and the Programmer circuit.

● Configuration of ROM Emulator

The built-in ROM emulator is the same structure with the mask ROM built-in S1C60N08. And used for loading the user-program. That has a capacity of 4,096 steps × 12 bits. The program area consists of 16 (0–15) pages × 256 (00H–FFH) steps. After initial reset, the program beginning address is set to bank 0, page 1, step 00H. The interrupt vector is allocated to page 1, steps 01H–0FH.

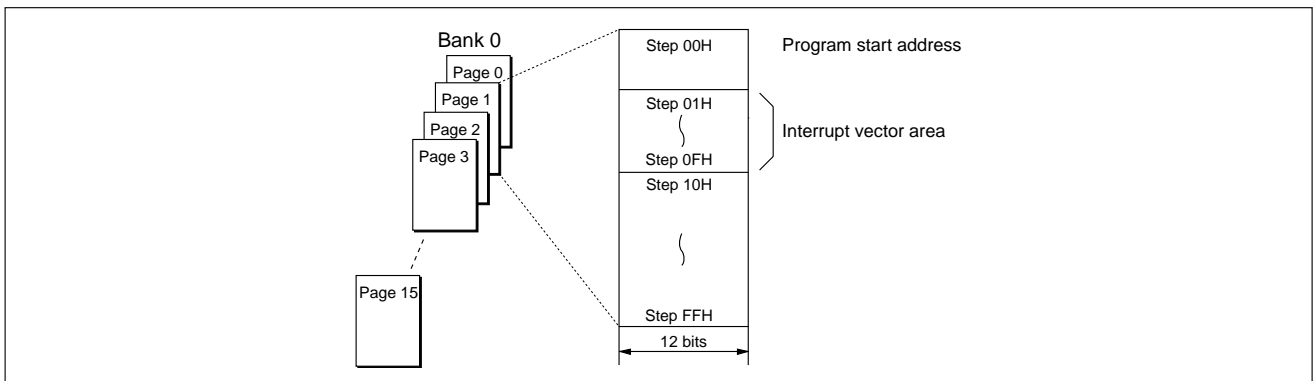

The ROM emulator data is downloaded from an external Serial EEPROM through the Programmer circuit. After power on or a HIGH pulse is input to the OTPRST pin, the ROM emulator data is initialized and downloading will be started.

● Configuration of ROM Emulator Programmer

The ROM emulator data is written through the Programmer. The Programmer supports data transmit/receive communication with Serial EEPROM, interface data error check and system reset signal generation.

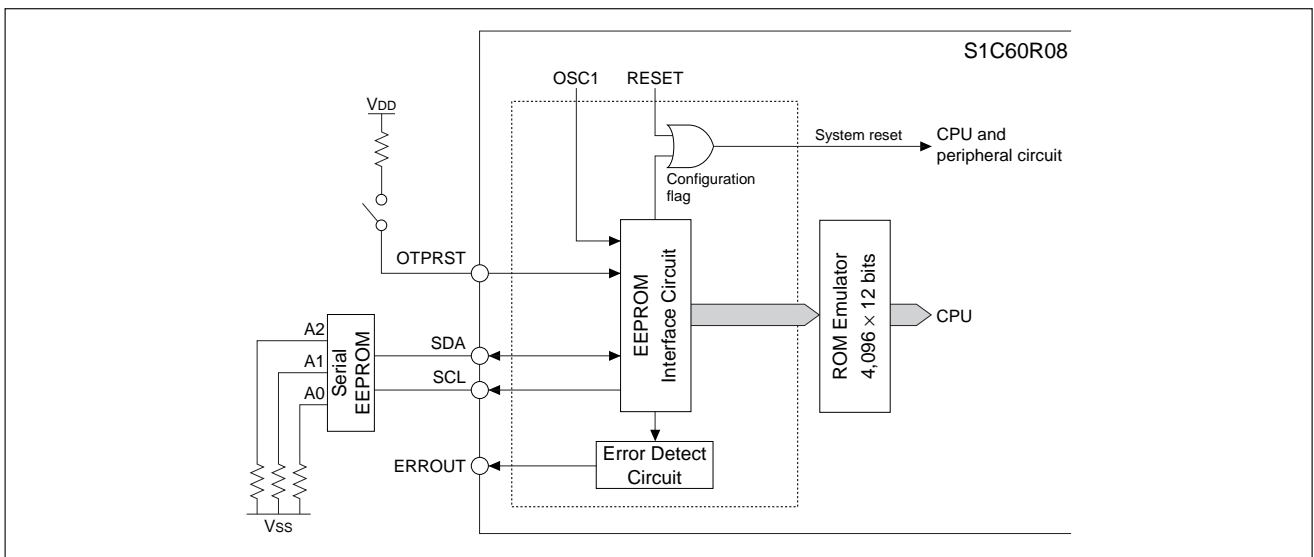

Terminals

The Programmer uses the following input/output terminals.

- SCL: Serial EEPROM control clock output terminal
- SDA: Serial EEPROM data transmit/receive terminal
- ERRROUT: Data check result output terminal
- OTPRST: Data re-loading start input terminal

● Operation

The S1C60R08 has two operation modes,

- Programming mode: Load the data from the Serial EEPROM
- Normal mode: Work as if the mask ROM type

The following describes how to operate the S1C60R08.

- 1) Make an application software.
- 2) Convert the software to the Serial EEPROM format with `winedg` in the S1C60R08 package.
- 3) Write the program which is converted to the Serial EEPROM format to the Serial EEPROM.
- 4) Set up the S1C60R08, the Serial EEPROM and the other peripheral components on the user target application. (The example is described in "BASIC EXTERNAL CONNECTION DIAGRAM".)
- 5) The application power on.
- 6) The S1C60R08 enters to the Programming mode, and starts data loading from the Serial EEPROM to the built-in ROM emulator automatically. In the loading, internal circuit is kept as system reset condition except the Programmer. And data error checking is done at the same time.
- 7) If the data error happens, the `ERROUT` pin goes HIGH level and data loading is terminated.
- 8) If the data has loaded without any error, the S1C60R08 enters to the Normal mode automatically. Then the CPU read the ROM emulator data as the instruction and start to run as if the mask ROM type.
- 9) If you want to re-load the data, input a HIGH pulse to the `OTPRST` pin. Then the S1C60R08 enters to Programming mode and starts re-loading.

■ SUMMARY OF NOTES

● Target Type for S1C60N08 Series

The S1C60N08 has 3 types (S1C60N08, S1C60A08 and S1C60L08).

In these models, the S1C60R08 supports the following 2 types as the ROM emulator model.

S1C60N08 $V_{DD} = 3.0\text{ V}$ (Typ.), OSC1

S1C60A08 $V_{DD} = 3.0\text{ V}$ (Typ.), OSC1/OSC3

Refer the "S1C60N08/60R08 Technical Manual".

● Mask/Segment Option

The S1C60R08 can load ROM emulator data. But cannot load the mask option and segment option. Therefore customer must make the function option data and segment option data by the S1C60R08 development tool at first. Then send the data to SEIKO EPSON and order the mask. SEIKO EPSON makes the S1C60R08 with a customized option according to this request.

● Serial EEPROM

The external Serial EEPROM is necessary for programming the ROM emulator data, and this component is recommended.

Recommended component: AK6010A/12A (AKM)
M24C64/32 (SGS-THOMSON)
BR24C64 (ROHM)
24AA64 (Microchip)

Note: Use larger EEPROM than program memory size.

S1C60N08/60R08

■ ELECTRICAL CHARACTERISTICS

● Absolute Maximum Ratings

S1C60N08/60A08/60R08

(V_{DD}=0V)

Rating	Symbol	Value	Unit
Supply voltage	V _{SS}	-5.0 to 0.5	V
Input voltage (1)	V _I	V _{SS} -0.3 to 0.5	V
Input voltage (2)	V _I OSC	V _{S1} -0.3 to 0.5	V
Permissible total output current *1	ΣI _{VSS}	10	mA
Operating temperature	T _{opr}	-20 to 70	°C
Storage temperature	T _{stg}	-65 to 150	°C
Soldering temperature / time	T _{sol}	260°C, 10sec (lead section)	—
Permissible dissipation *2	P _D	250	mW

*1: The permissible total output current is the sum total of the current (average current) that simultaneously flows from the output pins (or is draw in).

*2: In case of plastic package.

S1C60L08

(V_{DD}=0V)

Rating	Symbol	Value	Unit
Supply voltage	V _{SS}	-2.0 to 0.5	V
Input voltage (1)	V _I	V _{SS} -0.3 to 0.5	V
Input voltage (2)	V _I OSC	V _{S1} -0.3 to 0.5	V
Permissible total output current *1	ΣI _{VSS}	10	mA
Operating temperature	T _{opr}	-20 to 70	°C
Storage temperature	T _{stg}	-65 to 150	°C
Soldering temperature / time	T _{sol}	260°C, 10sec (lead section)	—
Permissible dissipation *2	P _D	250	mW

*1: The permissible total output current is the sum total of the current (average current) that simultaneously flows from the output pins (or is draw in).

*2: In case of plastic package.

● Recommended Operating Conditions

S1C60N08

(T_a=-20 to 70°C)

Condition	Symbol	Remark	Min.	Typ.	Max.	Unit
Supply voltage	V _{SS}	V _{DD} =0V	-3.5	-3.0	-1.8	V
Oscillation frequency	f _{OSC1}	Either one is selected	—	32.768	—	kHz
			—	38.400	—	kHz

S1C60L08

(T_a=-20 to 70°C)

Condition	Symbol	Remark	Min.	Typ.	Max.	Unit
Supply voltage	V _{SS}	V _{DD} =0V	-1.7	-1.5	-1.1	V
		V _{DD} =0V, with software control *1	-1.7	-1.5	-0.9 *2	V
		V _{DD} =0V, when analog comparator is used	-1.7	-1.5	-1.2	V
Oscillation frequency	f _{OSC1}	Either one is selected	—	32.768	—	kHz
			—	38.400	—	kHz

*1: When switching to heavy load protection mode.

*2: The possibility of LCD panel display differs depending on the characteristics of the LCD panel.

S1C60A08/60R08

(T_a=-20 to 70°C)

Condition	Symbol	Remark	Min.	Typ.	Max.	Unit
Supply voltage	V _{SS}	V _{DD} =0V	-3.5	-3.0	-2.2 *1	V
Oscillation frequency (1)	f _{OSC1}	Either one is selected	—	32.768	—	kHz
			—	38.400	—	kHz
Oscillation frequency (2)	f _{OSC3}	duty 50±5%, V _{SS} =-2.2 to -3.5V	50	500	600	kHz

*1: -1.8V when the S1C60R08 is used as the S1C60N08.

● DC Characteristics

S1C60N08/60A08/60R08

(Unless otherwise specified: $V_{DD}=0V$, $V_{SS}=-3.0V$, $f_{osc1}=32.768kHz$, $T_a=25^{\circ}C$, $V_{S1}/V_{L1}-V_{L3}$ are internal voltage, $C_1-C_5=0.1\mu F$)

Characteristic	Symbol	Condition	Min.	Typ.	Max.	Unit
High level input voltage (1)	V_{IH1}	K00-03, K10, K20-23, P00-03, P10-13 SIN, (SDA) *1	$0.2 \cdot V_{SS}$		0	V
High level input voltage (2)	V_{IH2}	SCLK, RESET, TEST, (OTPRST) *1	$0.1 \cdot V_{SS}$		0	V
Low level input voltage (1)	V_{IL1}	K00-03, K10, K20-23, P00-03, P10-13 SIN, (SDA) *1	V_{SS}		$0.8 \cdot V_{SS}$	V
Low level input voltage (2)	V_{IL2}	SCLK, RESET, TEST, (OTPRST) *1	V_{SS}		$0.9 \cdot V_{SS}$	V
High level input current (1)	I_{IH1}	$V_{IH1}=0V$ No pull-down K00-03, K10, K20-23, P00-03, P10-13 SIN, SCLK, AMPP, AMPM (SDA) *1	0		0.5	μA
High level input current (2)	I_{IH2}	$V_{IH2}=0V$ With pull-down K00-03, K10, K20-23 SIN, SCLK	4		16	μA
High level input current (3)	I_{IH3}	$V_{IH3}=0V$ With pull-down P00-03, P10-13, RESET, TEST (OTPRST) *1	25		100	μA
Low level input current	I_{IL}	$V_{IL}=V_{SS}$ K00-03, K10, K20-23, P00-03, P10-13 SIN, SCLK, AMPP, AMPM, RESET, TEST (OTPRST), (SDA) *1	-0.5		0	μA
High level output current (1)	I_{OH1}	$V_{OH1}=0.1 \cdot V_{SS}$ R10, R11, R13			-1.8	mA
High level output current (2)	I_{OH2}	$V_{OH2}=0.1 \cdot V_{SS}$ R00-03, R12, P00-03, P10-13, SOUT SCLK, (SDA), (ERROUT), (SCL) *1			-0.9	mA
Low level output current (1)	I_{OL1}	$V_{OL1}=0.9 \cdot V_{SS}$ R10, R11, R13	6.0			mA
Low level output current (2)	I_{OL2}	$V_{OL2}=0.9 \cdot V_{SS}$ R00-03, R12, P00-03, P10-13, SOUT SCLK, (SDA), (ERROUT), (SCL) *1	3.0			mA
Common output current	I_{OH3}	$V_{OH3}=-0.05V$ COM0-3			-3	μA
	I_{OL3}	$V_{OL3}=V_{L3}+0.05V$	3			μA
Segment output current (during LCD output)	I_{OH4}	$V_{OH4}=-0.05V$ SEG0-47			-3	μA
	I_{OL4}	$V_{OL4}=V_{L3}+0.05V$	3			μA
Segment output current (during DC output)	I_{OH5}	$V_{OH5}=0.1 \cdot V_{SS}$ SEG0-47			-200	μA
	I_{OL5}	$V_{OL5}=0.9 \cdot V_{SS}$	200			μA

*1: () indicate the S1C60R08 pins.

S1C60L08

(Unless otherwise specified: $V_{DD}=0V$, $V_{SS}=-1.5V$, $f_{osc1}=32.768kHz$, $T_a=25^{\circ}C$, $V_{S1}/V_{L1}-V_{L3}$ are internal voltage, $C_1-C_5=0.1\mu F$)

Characteristic	Symbol	Condition	Min.	Typ.	Max.	Unit
High level input voltage (1)	V_{IH1}	K00-03, K10, K20-23, P00-03, P10-13 SIN	$0.2 \cdot V_{SS}$		0	V
High level input voltage (2)	V_{IH2}	SCLK, RESET, TEST	$0.1 \cdot V_{SS}$		0	V
Low level input voltage (1)	V_{IL1}	K00-03, K10, K20-23, P00-03, P10-13 SIN	V_{SS}		$0.8 \cdot V_{SS}$	V
Low level input voltage (2)	V_{IL2}	SCLK, RESET, TEST	V_{SS}		$0.9 \cdot V_{SS}$	V
High level input current (1)	I_{IH1}	$V_{IH1}=0V$ No pull-down K00-03, K10, K20-23, P00-03, P10-13 SIN, SCLK AMPP, AMPM	0		0.5	μA
High level input current (2)	I_{IH2}	$V_{IH2}=0V$ With pull-down K00-03, K10, K20-23 SIN, SCLK	2		10	μA
High level input current (3)	I_{IH3}	$V_{IH3}=0V$ With pull-down P00-03, P10-13 RESET, TEST	12		60	μA
Low level input current	I_{IL}	$V_{IL}=V_{SS}$ K00-03, K10, K20-23, P00-03, P10-13 SIN, SCLK, AMPP, AMPM RESET, TEST	-0.5		0	μA
High level output current (1)	I_{OH1}	$V_{OH1}=0.1 \cdot V_{SS}$ R10, R11, R13			-300	μA
High level output current (2)	I_{OH2}	$V_{OH2}=0.1 \cdot V_{SS}$ R00-03, R12, P00-03, P10-13 SOUT, SCLK			-150	μA
Low level output current (1)	I_{OL1}	$V_{OL1}=0.9 \cdot V_{SS}$ R10, R11, R13	1400			μA
Low level output current (2)	I_{OL2}	$V_{OL2}=0.9 \cdot V_{SS}$ R00-03, R12, P00-03, P10-13 SOUT, SCLK	700			μA
Common output current	I_{OH3}	$V_{OH3}=-0.05V$ COM0-3			-3	μA
	I_{OL3}	$V_{OL3}=V_{L3}+0.05V$	3			μA
Segment output current (during LCD output)	I_{OH4}	$V_{OH4}=-0.05V$ SEG0-47			-3	μA
	I_{OL4}	$V_{OL4}=V_{L3}+0.05V$	3			μA
Segment output current (during DC output)	I_{OH5}	$V_{OH5}=0.1 \cdot V_{SS}$ SEG0-47			-100	μA
	I_{OL5}	$V_{OL5}=0.9 \cdot V_{SS}$	100			μA

S1C60N08/60R08

● Analog Circuit Characteristics and Current Consumption

S1C60N08 (Normal Operating Mode)

(Unless otherwise specified: $V_{DD}=0V$, $V_{SS}=-3.0V$, $f_{osc1}=32.768kHz$, $T_a=25^\circ C$, $C_G=25pF$, $V_{S1}/V_{L1}-V_{L3}$ are internal voltage, $C_1-C_5=0.1\mu F$)

Characteristic	Symbol	Condition	Min.	Typ.	Max.	Unit
LCD drive voltage	V_{L1}	Connect 1 M Ω load resistor between V_{DD} and V_{L1} (without panel load)	$1/2 \cdot V_{L2}$ - 0.1		$1/2 \cdot V_{L2}$ $\times 0.9$	V
	V_{L2}	Connect 1 M Ω load resistor between V_{DD} and V_{L2} (without panel load)	-2.30	-2.10	-1.90	V
	V_{L3}	Connect 1 M Ω load resistor between V_{DD} and V_{L3} (without panel load)	$3/2 \cdot V_{L2}$ - 0.1		$3/2 \cdot V_{L2}$ $\times 0.9$	V
BLD voltage *1	V_{B0}	BLC="0"	-2.35	-2.20	-2.05	V
	V_{B1}	BLC="1"	-2.40	-2.25	-2.10	V
	V_{B2}	BLC="2"	-2.45	-2.30	-2.15	V
	V_{B3}	BLC="3"	-2.50	-2.35	-2.20	V
	V_{B4}	BLC="4"	-2.55	-2.40	-2.25	V
	V_{B5}	BLC="5"	-2.60	-2.45	-2.30	V
	V_{B6}	BLC="6"	-2.65	-2.50	-2.35	V
	V_{B7}	BLC="7"	-2.70	-2.55	-2.40	V
BLD circuit response time	t_B				100	μsec
Sub-BLD voltage	V_{BS}		-2.55	-2.40	-2.25	V
Sub-BLD circuit response time	t_{BS}				100	μsec
Analog comparator input voltage	V_{IP}	Non-inverted input (AMPP)	$V_{SS}+0.3$		$V_{DD}-0.9$	V
	V_{IM}	Inverted input (AMPM)				
Analog comparator offset voltage	V_{OF}				10	mV
Analog comparator response time	t_{AMP}	$V_{IP}=-1.5V$ $V_{IM}=V_{IP}\pm 15mV$			3	msec
Current consumption	I_{OP}	During HALT		1.0	2.0	μA
		During operation *2	Without panel load	2.2	4.0	μA

*1: The relationships among $V_{B0}-V_{B7}$ are $V_{B0}>V_{B1}>V_{B2}>...>V_{B5}>V_{B6}>V_{B7}$.

*2: The BLD circuit, sub-BLD circuit and analog comparator are in the OFF status.

S1C60N08 (Heavy Load Protection Mode)

(Unless otherwise specified: $V_{DD}=0V$, $V_{SS}=-3.0V$, $f_{osc1}=32.768kHz$, $T_a=25^\circ C$, $C_G=25pF$, $V_{S1}/V_{L1}-V_{L3}$ are internal voltage, $C_1-C_5=0.1\mu F$)

Characteristic	Symbol	Condition	Min.	Typ.	Max.	Unit
LCD drive voltage	V_{L1}	Connect 1 M Ω load resistor between V_{DD} and V_{L1} (without panel load)	$1/2 \cdot V_{L2}$ - 0.1		$1/2 \cdot V_{L2}$ $\times 0.9$	V
	V_{L2}	Connect 1 M Ω load resistor between V_{DD} and V_{L2} (without panel load)	-2.30	-2.10	-1.90	V
	V_{L3}	Connect 1 M Ω load resistor between V_{DD} and V_{L3} (without panel load)	$3/2 \cdot V_{L2}$ - 0.1		$3/2 \cdot V_{L2}$ $\times 0.9$	V
BLD voltage *1	V_{B0}	BLC="0"	-2.35	-2.20	-2.05	V
	V_{B1}	BLC="1"	-2.40	-2.25	-2.10	V
	V_{B2}	BLC="2"	-2.45	-2.30	-2.15	V
	V_{B3}	BLC="3"	-2.50	-2.35	-2.20	V
	V_{B4}	BLC="4"	-2.55	-2.40	-2.25	V
	V_{B5}	BLC="5"	-2.60	-2.45	-2.30	V
	V_{B6}	BLC="6"	-2.65	-2.50	-2.35	V
	V_{B7}	BLC="7"	-2.70	-2.55	-2.40	V
BLD circuit response time	t_B				100	μsec
Sub-BLD voltage	V_{BS}		-2.55	-2.40	-2.25	V
Sub-BLD circuit response time	t_{BS}				100	μsec
Analog comparator input voltage	V_{IP}	Non-inverted input (AMPP)	$V_{SS}+0.3$		$V_{DD}-0.9$	V
	V_{IM}	Inverted input (AMPM)				
Analog comparator offset voltage	V_{OF}				10	mV
Analog comparator response time	t_{AMP}	$V_{IP}=-1.5V$ $V_{IM}=V_{IP}\pm 15mV$			3	msec
Current consumption	I_{OP}	During HALT		10	20	μA
		During operation *2	Without panel load	12	25	μA

*1: The relationships among $V_{B0}-V_{B7}$ are $V_{B0}>V_{B1}>V_{B2}>...>V_{B5}>V_{B6}>V_{B7}$.

*2: The BLD circuit and sub-BLD circuit are in the ON status (HLMOD="1", BLS="0").

The analog comparator is in the OFF status.

S1C60L08 (Normal Operating Mode)

(Unless otherwise specified: $V_{DD}=0V$, $V_{SS}=-1.5V$, $f_{osc1}=32.768kHz$, $T_a=25^{\circ}C$, $C_G=25pF$, $V_{S1}/V_{L1}-V_{L3}$ are internal voltage, $C_1-C_5=0.1\mu F$)

Characteristic	Symbol	Condition	Min.	Typ.	Max.	Unit
LCD drive voltage	V_{L1}	Connect 1 M Ω load resistor between V_{DD} and V_{L1} (without panel load)	-1.15	-1.05	-0.95	V
	V_{L2}	Connect 1 M Ω load resistor between V_{DD} and V_{L2} (without panel load)	2· V_{L1} - 0.1		2· V_{L1} ×0.9	V
	V_{L3}	Connect 1 M Ω load resistor between V_{DD} and V_{L3} (without panel load)	3· V_{L1} - 0.1		3· V_{L1} ×0.9	V
BLD voltage *1	V_{B0}	BLC="0"	-1.15	-1.05	-0.95	V
	V_{B1}	BLC="1"	-1.20	-1.10	-1.00	V
	V_{B2}	BLC="2"	-1.25	-1.15	-1.05	V
	V_{B3}	BLC="3"	-1.30	-1.20	-1.10	V
	V_{B4}	BLC="4"	-1.35	-1.25	-1.15	V
	V_{B5}	BLC="5"	-1.40	-1.30	-1.20	V
	V_{B6}	BLC="6"	-1.45	-1.35	-1.25	V
	V_{B7}	BLC="7"	-1.50	-1.40	-1.30	V
BLD circuit response time	t_B				100	μ sec
Sub-BLD voltage	V_{BS}		-1.30	-1.20	-1.10	V
Sub-BLD circuit response time	t_{BS}				100	μ sec
Analog comparator input voltage	V_{IP}	Non-inverted input (AMPP)	$V_{SS}+0.3$		$V_{DD}-0.9$	V
	V_{IM}	Inverted input (AMPM)				
Analog comparator offset voltage	V_{OF}				20	mV
Analog comparator response time	t_{AMP}	$V_{IP}=-1.1V$ $V_{IM}=V_{IP}\pm 30mV$			3	msec
Current consumption	IOP	During HALT	Without panel load	1.0	2.0	μ A
		During operation *2		2.2	4.0	μ A

*1: The relationships among $V_{B0}-V_{B7}$ are $V_{B0}>V_{B1}>V_{B2}>...>V_{B5}>V_{B6}>V_{B7}$.

*2: The BLD circuit, sub-BLD circuit and analog comparator are in the OFF status.

S1C60L08 (Heavy Load Protection Mode)

(Unless otherwise specified: $V_{DD}=0V$, $V_{SS}=-1.5V$, $f_{osc1}=32.768kHz$, $T_a=25^{\circ}C$, $C_G=25pF$, $V_{S1}/V_{L1}-V_{L3}$ are internal voltage, $C_1-C_5=0.1\mu F$)

Characteristic	Symbol	Condition	Min.	Typ.	Max.	Unit
LCD drive voltage	V_{L1}	Connect 1 M Ω load resistor between V_{DD} and V_{L1} (without panel load)	-1.15	-1.05	-0.95	V
	V_{L2}	Connect 1 M Ω load resistor between V_{DD} and V_{L2} (without panel load)	2· V_{L1} - 0.1		2· V_{L1} ×0.85	V
	V_{L3}	Connect 1 M Ω load resistor between V_{DD} and V_{L3} (without panel load)	3· V_{L1} - 0.1		3· V_{L1} ×0.85	V
BLD voltage *1	V_{B0}	BLC="0"	-1.15	-1.05	-0.95	V
	V_{B1}	BLC="1"	-1.20	-1.10	-1.00	V
	V_{B2}	BLC="2"	-1.25	-1.15	-1.05	V
	V_{B3}	BLC="3"	-1.30	-1.20	-1.10	V
	V_{B4}	BLC="4"	-1.35	-1.25	-1.15	V
	V_{B5}	BLC="5"	-1.40	-1.30	-1.20	V
	V_{B6}	BLC="6"	-1.45	-1.35	-1.25	V
	V_{B7}	BLC="7"	-1.50	-1.40	-1.30	V
BLD circuit response time	t_B				100	μ sec
Sub-BLD voltage	V_{BS}		-1.30	-1.20	-1.10	V
Sub-BLD circuit response time	t_{BS}				100	μ sec
Analog comparator input voltage	V_{IP}	Non-inverted input (AMPP)	$V_{SS}+0.3$		$V_{DD}-0.9$	V
	V_{IM}	Inverted input (AMPM)				
Analog comparator offset voltage	V_{OF}				20	mV
Analog comparator response time	t_{AMP}	$V_{IP}=-1.1V$ $V_{IM}=V_{IP}\pm 30mV$			3	msec
Current consumption	IOP	During HALT	Without panel load	6.5	10	μ A
		During operation *2		8.5	15	μ A

*1: The relationships among $V_{B0}-V_{B7}$ are $V_{B0}>V_{B1}>V_{B2}>...>V_{B5}>V_{B6}>V_{B7}$.

*2: The BLD circuit and sub-BLD circuit are in the ON status (HLMOD="1", BLS="0").
The analog comparator is in the OFF status.

S1C60N08/60R08

S1C60A08 (Normal Operating Mode)

(Unless otherwise specified: V_{DD}=0V, V_{SS}=-3.0V, f_{osc1}=32.768kHz, T_a=25°C, C_G=25pF, V_{s1}/V_{L1}-V_{L3} are internal voltage, C₁-C₅=0.1μF)

Characteristic	Symbol	Condition	Min.	Typ.	Max.	Unit
LCD drive voltage	V _{L1}	Connect 1 MΩ load resistor between V _{DD} and V _{L1} (without panel load)	-1.15	-1.05	-0.95	V
	V _{L2}	Connect 1 MΩ load resistor between V _{DD} and V _{L2} (without panel load)	2·V _{L1} - 0.1		2·V _{L1} ×0.9	V
	V _{L3}	Connect 1 MΩ load resistor between V _{DD} and V _{L3} (without panel load)	3·V _{L1} - 0.1		3·V _{L1} ×0.9	V
BLD voltage *1	V _{B0}	BLC="0"	-2.35	-2.20	-2.05	V
	V _{B1}	BLC="1"	-2.40	-2.25	-2.10	V
	V _{B2}	BLC="2"	-2.45	-2.30	-2.15	V
	V _{B3}	BLC="3"	-2.50	-2.35	-2.20	V
	V _{B4}	BLC="4"	-2.55	-2.40	-2.25	V
	V _{B5}	BLC="5"	-2.60	-2.45	-2.30	V
	V _{B6}	BLC="6"	-2.65	-2.50	-2.35	V
	V _{B7}	BLC="7"	-2.70	-2.55	-2.40	V
BLD circuit response time	t _B				100	μsec
Sub-BLD voltage	V _{BS}		-2.55	-2.40	-2.25	V
Sub-BLD circuit response time	t _{BS}				100	μsec
Analog comparator input voltage	V _{IP}	Non-inverted input (AMPP)	V _{SS} +0.3		V _{DD} -0.9	V
	V _{IM}	Inverted input (AMPM)				
Analog comparator offset voltage	V _{OF}				10	mV
Analog comparator response time	t _{AMP}	V _{IP} =-1.5V V _{IM} =V _{IP} ±15mV			3	msec
Current consumption	I _{OP}	During HALT		1.1	2.0	μA
		During operation *2	Without panel load	3.0	5.0	μA
		During operation at 500kHz *2		50	70	μA

*1: The relationships among V_{B0}-V_{B7} are V_{B0}>V_{B1}>V_{B2}>...V_{B5}>V_{B6}>V_{B7}.

*2: The BLD circuit, sub-BLD circuit and analog comparator are in the OFF status.

S1C60A08 (Heavy Load Protection Mode)

(Unless otherwise specified: V_{DD}=0V, V_{SS}=-3.0V, f_{osc1}=32.768kHz, T_a=25°C, C_G=25pF, V_{s1}/V_{L1}-V_{L3} are internal voltage, C₁-C₅=0.1μF)

Characteristic	Symbol	Condition	Min.	Typ.	Max.	Unit
LCD drive voltage	V _{L1}	Connect 1 MΩ load resistor between V _{DD} and V _{L1} (without panel load)	-1.15	-1.05	-0.95	V
	V _{L2}	Connect 1 MΩ load resistor between V _{DD} and V _{L2} (without panel load)	2·V _{L1} - 0.1		2·V _{L1} ×0.9	V
	V _{L3}	Connect 1 MΩ load resistor between V _{DD} and V _{L3} (without panel load)	3·V _{L1} - 0.1		3·V _{L1} ×0.9	V
BLD voltage *1	V _{B0}	BLC="0"	-2.35	-2.20	-2.05	V
	V _{B1}	BLC="1"	-2.40	-2.25	-2.10	V
	V _{B2}	BLC="2"	-2.45	-2.30	-2.15	V
	V _{B3}	BLC="3"	-2.50	-2.35	-2.20	V
	V _{B4}	BLC="4"	-2.55	-2.40	-2.25	V
	V _{B5}	BLC="5"	-2.60	-2.45	-2.30	V
	V _{B6}	BLC="6"	-2.65	-2.50	-2.35	V
	V _{B7}	BLC="7"	-2.70	-2.55	-2.40	V
BLD circuit response time	t _B				100	μsec
Sub-BLD voltage	V _{BS}		-2.55	-2.40	-2.25	V
Sub-BLD circuit response time	t _{BS}				100	μsec
Analog comparator input voltage	V _{IP}	Non-inverted input (AMPP)	V _{SS} +0.3		V _{DD} -0.9	V
	V _{IM}	Inverted input (AMPM)				
Analog comparator offset voltage	V _{OF}				10	mV
Analog comparator response time	t _{AMP}	V _{IP} =-1.5V V _{IM} =V _{IP} ±15mV			3	msec
Current consumption	I _{OP}	During HALT		6.5	10	μA
		During operation *2	Without panel load	8.5	15	μA
		During operation at 500kHz *2		55	75	μA

*1: The relationships among V_{B0}-V_{B7} are V_{B0}>V_{B1}>V_{B2}>...V_{B5}>V_{B6}>V_{B7}.

*2: The BLD circuit and sub-BLD circuit are in the ON status (HLMOD="1", BLS="0").
The analog comparator is in the OFF status.

S1C60R08 (Normal Operating Mode) Target: S1C60N08

(Unless otherwise specified: $V_{DD}=0V$, $V_{SS}=-3.0V$, $f_{osc1}=32.768kHz$, $T_a=25^{\circ}C$, $C_G=25pF$, $V_{S1}/V_{L1}-V_{L3}$ are internal voltage, $C_1-C_5=0.1\mu F$)

Characteristic	Symbol	Condition	Min.	Typ.	Max.	Unit
LCD drive voltage	V _{L1}	Connect 1 MΩ load resistor between V _{DD} and V _{L1} (without panel load)	1/2·V _{L2} - 0.1		1/2·V _{L2} ×0.9	V
	V _{L2}	Connect 1 MΩ load resistor between V _{DD} and V _{L2} (without panel load)	-2.30	-2.10	-1.90	V
	V _{L3}	Connect 1 MΩ load resistor between V _{DD} and V _{L3} (without panel load)	3/2·V _{L2} - 0.1		3/2·V _{L2} ×0.9	V
BLD voltage *1	V _{B0}	BLC="0"	-2.35	-2.20	-2.05	V
	V _{B1}	BLC="1"	-2.40	-2.25	-2.10	V
	V _{B2}	BLC="2"	-2.45	-2.30	-2.15	V
	V _{B3}	BLC="3"	-2.50	-2.35	-2.20	V
	V _{B4}	BLC="4"	-2.55	-2.40	-2.25	V
	V _{B5}	BLC="5"	-2.60	-2.45	-2.30	V
	V _{B6}	BLC="6"	-2.65	-2.50	-2.35	V
	V _{B7}	BLC="7"	-2.70	-2.55	-2.40	V
BLD circuit response time	t _B				100	μsec
Sub-BLD voltage	V _{BS}		-2.55	-2.40	-2.25	V
Sub-BLD circuit response time	t _{BS}				100	μsec
Analog comparator input voltage	V _{IP}	Non-inverted input (AMPP)	V _{SS} +0.3		V _{DD} -0.9	V
	V _{IM}	Inverted input (AMPM)				
Analog comparator offset voltage	V _{OF}				10	mV
Analog comparator response time	t _{AMP}	V _{IP} =-1.5V V _{IM} =V _{IP} ±15mV			3	msec
Current consumption	I _{OP}	During HALT	Without panel load	1.0	2.0	μA
		During operation *2		6.5	9.0	μA

*1: The relationships among V_{B0}-V_{B7} are V_{B0}>V_{B1}>V_{B2}>...>V_{B5}>V_{B6}>V_{B7}.

*2: The BLD circuit, sub-BLD circuit and analog comparator are in the OFF status.

S1C60R08 (Heavy Load Protection Mode) Target: S1C60N08

(Unless otherwise specified: $V_{DD}=0V$, $V_{SS}=-3.0V$, $f_{osc1}=32.768kHz$, $T_a=25^{\circ}C$, $C_G=25pF$, $V_{S1}/V_{L1}-V_{L3}$ are internal voltage, $C_1-C_5=0.1\mu F$)

Characteristic	Symbol	Condition	Min.	Typ.	Max.	Unit
LCD drive voltage	V _{L1}	Connect 1 MΩ load resistor between V _{DD} and V _{L1} (without panel load)	1/2·V _{L2} - 0.1		1/2·V _{L2} ×0.9	V
	V _{L2}	Connect 1 MΩ load resistor between V _{DD} and V _{L2} (without panel load)	-2.30	-2.10	-1.90	V
	V _{L3}	Connect 1 MΩ load resistor between V _{DD} and V _{L3} (without panel load)	3/2·V _{L2} - 0.1		3/2·V _{L2} ×0.9	V
BLD voltage *1	V _{B0}	BLC="0"	-2.35	-2.20	-2.05	V
	V _{B1}	BLC="1"	-2.40	-2.25	-2.10	V
	V _{B2}	BLC="2"	-2.45	-2.30	-2.15	V
	V _{B3}	BLC="3"	-2.50	-2.35	-2.20	V
	V _{B4}	BLC="4"	-2.55	-2.40	-2.25	V
	V _{B5}	BLC="5"	-2.60	-2.45	-2.30	V
	V _{B6}	BLC="6"	-2.65	-2.50	-2.35	V
	V _{B7}	BLC="7"	-2.70	-2.55	-2.40	V
BLD circuit response time	t _B				100	μsec
Sub-BLD voltage	V _{BS}		-2.55	-2.40	-2.25	V
Sub-BLD circuit response time	t _{BS}				100	μsec
Analog comparator input voltage	V _{IP}	Non-inverted input (AMPP)	V _{SS} +0.3		V _{DD} -0.9	V
	V _{IM}	Inverted input (AMPM)				
Analog comparator offset voltage	V _{OF}				10	mV
Analog comparator response time	t _{AMP}	V _{IP} =-1.5V V _{IM} =V _{IP} ±15mV			3	msec
Current consumption	I _{OP}	During HALT	Without panel load	6.5	10	μA
		During operation *2		11.5	20	μA

*1: The relationships among V_{B0}-V_{B7} are V_{B0}>V_{B1}>V_{B2}>...>V_{B5}>V_{B6}>V_{B7}.

*2: The BLD circuit and sub-BLD circuit are in the ON status (HLMOD="1", BLS="0").

The analog comparator is in the OFF status.

S1C60N08/60R08

S1C60R08 (Normal Operating Mode) Target: S1C60A08

(Unless otherwise specified: $V_{DD}=0V$, $V_{SS}=-3.0V$, $f_{osc1}=32.768kHz$, $T_a=25^\circ C$, $C_G=25pF$, $V_{S1}/V_{L1}-V_{L3}$ are internal voltage, $C_1-C_5=0.1\mu F$)

Characteristic	Symbol	Condition	Min.	Typ.	Max.	Unit
LCD drive voltage	VL1	Connect 1 MΩ load resistor between VDD and VL1 (without panel load)	-1.15	-1.05	-0.95	V
	VL2	Connect 1 MΩ load resistor between VDD and VL2 (without panel load)	2·VL1 - 0.1		2·VL1 ×0.9	V
	VL3	Connect 1 MΩ load resistor between VDD and VL3 (without panel load)	3·VL1 - 0.1		3·VL1 ×0.9	V
BLD voltage *1	VB0	BLC="0"	-2.35	-2.20	-2.05	V
	VB1	BLC="1"	-2.40	-2.25	-2.10	V
	VB2	BLC="2"	-2.45	-2.30	-2.15	V
	VB3	BLC="3"	-2.50	-2.35	-2.20	V
	VB4	BLC="4"	-2.55	-2.40	-2.25	V
	VB5	BLC="5"	-2.60	-2.45	-2.30	V
	VB6	BLC="6"	-2.65	-2.50	-2.35	V
BLD circuit response time	t _b				100	μsec
Sub-BLD voltage	V _{BS}		-2.55	-2.40	-2.25	V
Sub-BLD circuit response time	t _{BS}				100	μsec
Analog comparator input voltage	V _{IP}	Non-inverted input (AMPP)	V _{SS} +0.3		V _{DD} -0.9	V
	V _{IM}	Inverted input (AMPM)				
Analog comparator offset voltage	V _{OF}				10	mV
Analog comparator response time	t _{AMP}	V _{IP} =-1.5V V _{IM} =V _{IP} ±15mV			3	msec
Current consumption	I _{OP}	During HALT		1.1	2.0	μA
		During operation *2	Without panel load	7.5	10	μA
		During operation at 500kHz *2		115	150	μA

*1: The relationships among V_{B0}-V_{B7} are V_{B0}>V_{B1}>V_{B2}>...>V_{B5}>V_{B6}>V_{B7}.

*2: The BLD circuit, sub-BLD circuit and analog comparator are in the OFF status.

S1C60R08 (Heavy Load Protection Mode) Target: S1C60A08

(Unless otherwise specified: $V_{DD}=0V$, $V_{SS}=-3.0V$, $f_{osc1}=32.768kHz$, $T_a=25^\circ C$, $C_G=25pF$, $V_{S1}/V_{L1}-V_{L3}$ are internal voltage, $C_1-C_5=0.1\mu F$)

Characteristic	Symbol	Condition	Min.	Typ.	Max.	Unit
LCD drive voltage	VL1	Connect 1 MΩ load resistor between VDD and VL1 (without panel load)	-1.15	-1.05	-0.95	V
	VL2	Connect 1 MΩ load resistor between VDD and VL2 (without panel load)	2·VL1 - 0.1		2·VL1 ×0.9	V
	VL3	Connect 1 MΩ load resistor between VDD and VL3 (without panel load)	3·VL1 - 0.1		3·VL1 ×0.9	V
BLD voltage *1	VB0	BLC="0"	-2.35	-2.20	-2.05	V
	VB1	BLC="1"	-2.40	-2.25	-2.10	V
	VB2	BLC="2"	-2.45	-2.30	-2.15	V
	VB3	BLC="3"	-2.50	-2.35	-2.20	V
	VB4	BLC="4"	-2.55	-2.40	-2.25	V
	VB5	BLC="5"	-2.60	-2.45	-2.30	V
	VB6	BLC="6"	-2.65	-2.50	-2.35	V
BLD circuit response time	t _b				100	μsec
Sub-BLD voltage	V _{BS}		-2.55	-2.40	-2.25	V
Sub-BLD circuit response time	t _{BS}				100	μsec
Analog comparator input voltage	V _{IP}	Non-inverted input (AMPP)	V _{SS} +0.3		V _{DD} -0.9	V
	V _{IM}	Inverted input (AMPM)				
Analog comparator offset voltage	V _{OF}				10	mV
Analog comparator response time	t _{AMP}	V _{IP} =-1.5V V _{IM} =V _{IP} ±15mV			3	msec
Current consumption	I _{OP}	During HALT		6.5	10	μA
		During operation *2	Without panel load	12.5	20	μA
		During operation at 500kHz *2		120	160	μA

*1: The relationships among V_{B0}-V_{B7} are V_{B0}>V_{B1}>V_{B2}>...>V_{B5}>V_{B6}>V_{B7}.

*2: The BLD circuit and sub-BLD circuit are in the ON status (HLMOD="1", BLS="0").
The analog comparator is in the OFF status.

● Oscillation Characteristics

Oscillation characteristics will vary according to different conditions (elements used, board pattern). Use the following characteristics as reference values.

S1C60N08/60R08 (OSC1 Crystal Oscillation)

(Unless otherwise specified: $V_{DD}=0V$, $V_{SS}=-3.0V$, Crystal: Q13MC146, $C_G=25pF$, $C_D=$ built-in, $T_a=25^\circ C$)

Characteristic	Symbol	Condition	Min.	Typ.	Max.	Unit
Oscillation start voltage	V_{sta}	$t_{sta} \leq 5\text{sec}$ (V_{ss})	-1.8			V
Oscillation stop voltage	V_{stp}	$t_{stp} \leq 10\text{sec}$ (V_{ss})	-1.8			V
Built-in capacitance (drain)	C_D	Including the parasitic capacitance inside the chip		20		pF
Frequency/voltage deviation	$\Delta f/\Delta V$	$V_{ss}=-1.8$ to $-3.5V$			5	ppm
Frequency/IC deviation	$\Delta f/\Delta IC$		-10		10	ppm
Frequency adjustment range	$\Delta f/\Delta C_G$	$C_G=5$ to $25pF$	35	45		ppm
Harmonic oscillation start voltage	V_{hho}	(V_{ss})			-3.5	V
Permitted leak resistance	R_{leak}	Between OSC1 and V_{DD}	200			M Ω

S1C60L08 (OSC1 Crystal Oscillation)

(Unless otherwise specified: $V_{DD}=0V$, $V_{SS}=-1.5V$, Crystal: Q13MC146, $C_G=25pF$, $C_D=$ built-in, $T_a=25^\circ C$)

Characteristic	Symbol	Condition	Min.	Typ.	Max.	Unit
Oscillation start voltage	V_{sta}	$t_{sta} \leq 5\text{sec}$ (V_{ss})	-1.1			V
Oscillation stop voltage	V_{stp}	$t_{stp} \leq 10\text{sec}$ (V_{ss})	-1.1 (-0.9)*1			V
Built-in capacitance (drain)	C_D	Including the parasitic capacitance inside the chip		20		pF
Frequency/voltage deviation	$\Delta f/\Delta V$	$V_{ss}=-1.1$ (-0.9)*1 to $-1.7V$			5	ppm
Frequency/IC deviation	$\Delta f/\Delta IC$		-10		10	ppm
Frequency adjustment range	$\Delta f/\Delta C_G$	$C_G=5$ to $25pF$	35	45		ppm
Harmonic oscillation start voltage	V_{hho}	(V_{ss})			-1.7	V
Permitted leak resistance	R_{leak}	Between OSC1 and V_{DD}	200			M Ω

*1: Parentheses indicate value for operation in heavy load protection mode.

S1C60A08 (OSC1 Crystal Oscillation)

(Unless otherwise specified: $V_{DD}=0V$, $V_{SS}=-3.0V$, Crystal: Q13MC146, $C_G=25pF$, $C_D=$ built-in, $T_a=25^\circ C$)

Characteristic	Symbol	Condition	Min.	Typ.	Max.	Unit
Oscillation start voltage	V_{sta}	$t_{sta} \leq 5\text{sec}$ (V_{ss})	-2.2			V
Oscillation stop voltage	V_{stp}	$t_{stp} \leq 10\text{sec}$ (V_{ss})	-2.2			V
Built-in capacitance (drain)	C_D	Including the parasitic capacitance inside the chip		20		pF
Frequency/voltage deviation	$\Delta f/\Delta V$	$V_{ss}=-2.2$ to $-3.5V$			5	ppm
Frequency/IC deviation	$\Delta f/\Delta IC$		-10		10	ppm
Frequency adjustment range	$\Delta f/\Delta C_G$	$C_G=5$ to $25pF$	35	45		ppm
Harmonic oscillation start voltage	V_{hho}	(V_{ss})			-3.5	V
Permitted leak resistance	R_{leak}	Between OSC1 and V_{DD}	200			M Ω

S1C60A08/60R08 (OSC3 CR Oscillation)

(Unless otherwise specified: $V_{DD}=0V$, $V_{SS}=-3.0V$, $R_{CR}=82k\Omega$, $T_a=25^\circ C$)

Characteristic	Symbol	Condition	Min.	Typ.	Max.	Unit
Oscillation frequency dispersion	f_{osc3}		-30	480kHz	30	%
Oscillation start voltage	V_{sta}	(V_{ss})	-2.2			V
Oscillation start time	t_{sta}	$V_{ss}=-2.2$ to $-3.5V$			3	msec
Oscillation stop voltage	V_{stp}	(V_{ss})	-2.2			V

S1C60A08/60R08 (OSC3 Ceramic Oscillation)

(Unless otherwise specified: $V_{DD}=0V$, $V_{SS}=-3.0V$, Ceramic oscillator: 500kHz, $C_{GC}=C_{DC}=100pF$, $T_a=25^\circ C$)

Characteristic	Symbol	Condition	Min.	Typ.	Max.	Unit
Oscillation start voltage	V_{sta}	(V_{ss})	-2.2			V
Oscillation start time	t_{sta}	$V_{ss}=-2.2$ to $-3.5V$			5	msec
Oscillation stop voltage	V_{stp}	(V_{ss})	-2.2			V

S1C60N08/60R08

■ BASIC EXTERNAL CONNECTION DIAGRAM

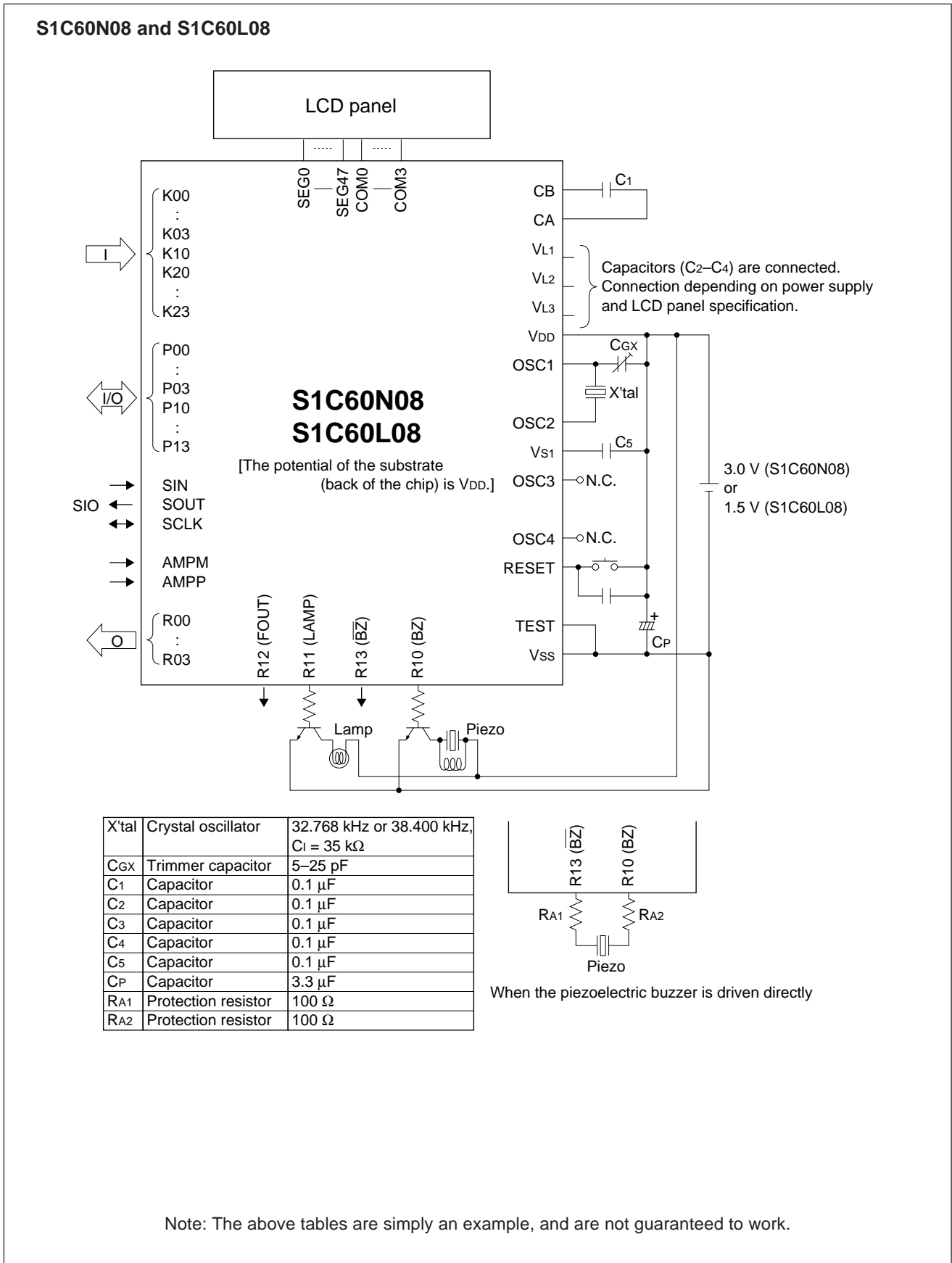

S1C60A08

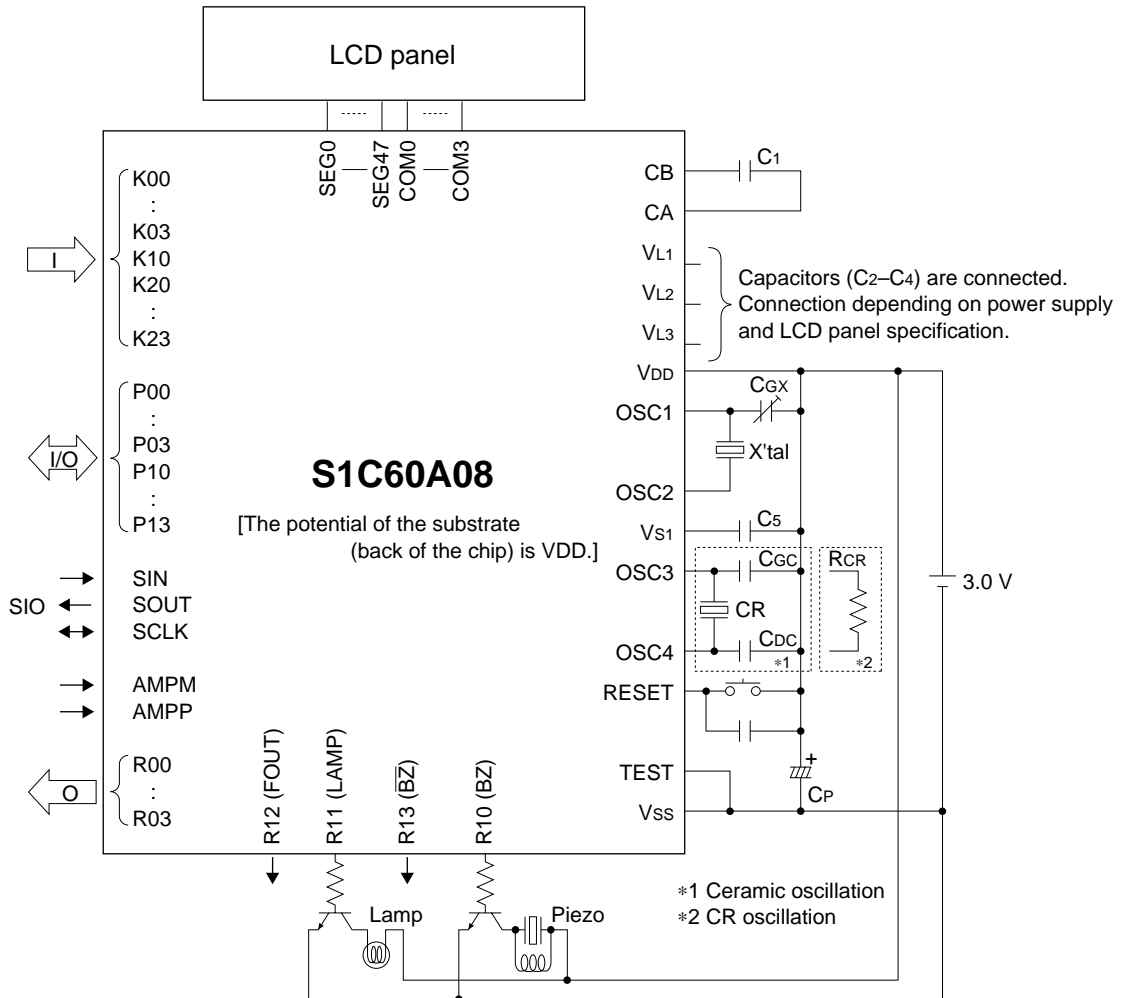

X'tal	Crystal oscillator	32.768 kHz or 38.400 kHz, C _i = 35 kΩ
C _{GX}	Trimmer capacitor	5–25 pF
CR	Ceramic oscillator	500 kHz
C _{ec}	Gate capacitor	100 pF
C _{dc}	Drain capacitor	100 pF
R _{CR}	Resistor for CR oscillation	82 kΩ
C ₁	Capacitor	0.1 μF
C ₂	Capacitor	0.1 μF
C ₃	Capacitor	0.1 μF
C ₄	Capacitor	0.1 μF
C ₅	Capacitor	0.1 μF
C _P	Capacitor	3.3 μF
R _{A1}	Protection resistor	100 Ω
R _{A2}	Protection resistor	100 Ω

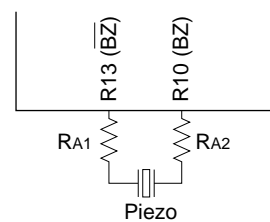

When the piezoelectric buzzer is driven directly

Note: The above tables are simply an example, and are not guaranteed to work.

S1C60N08/60R08

S1C60R08 (Target for S1C60N08)

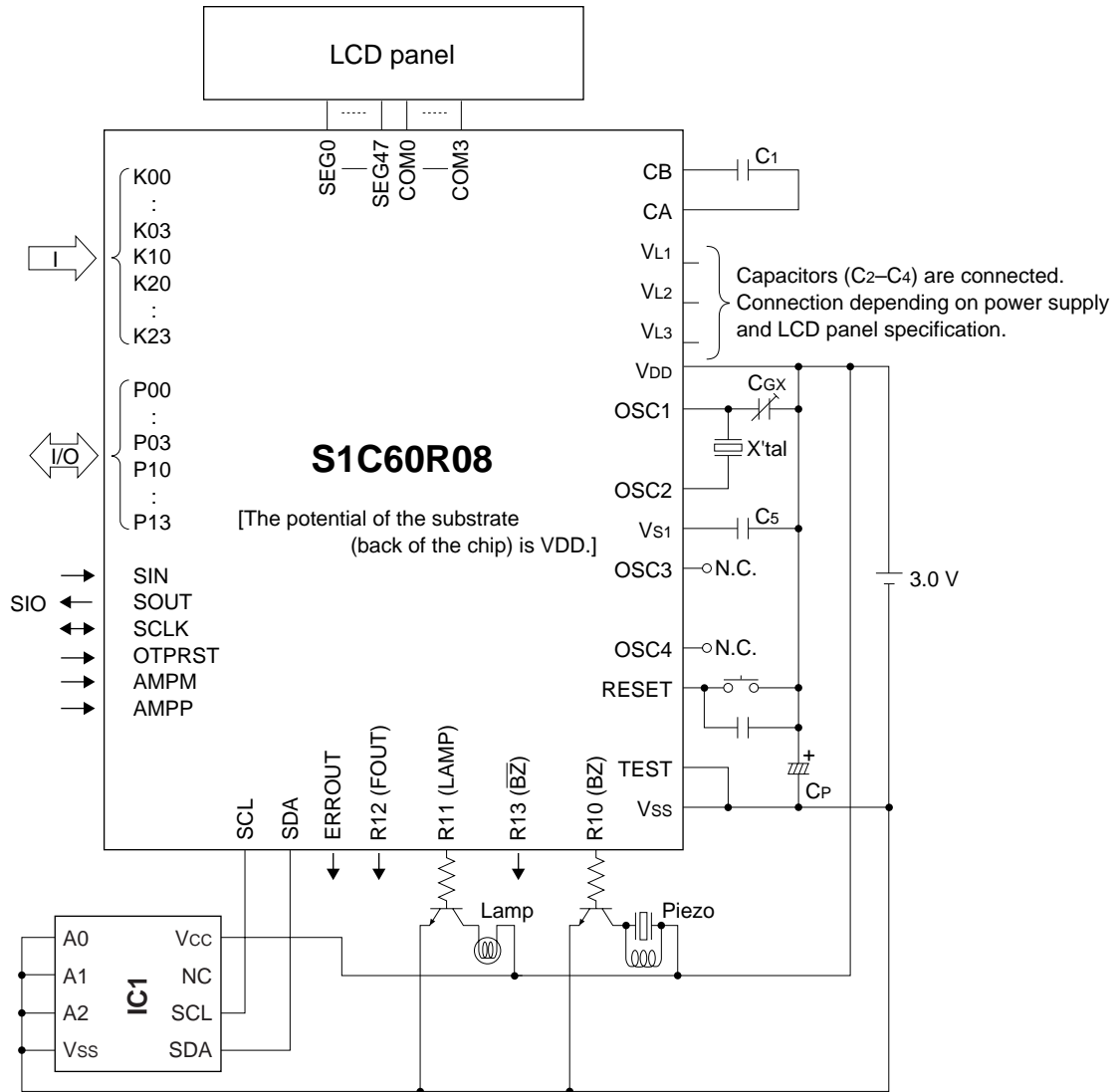

X'tal	Crystal oscillator	32.768 kHz or 38.400 kHz
C _{GX}	Trimmer capacitor	5–25 pF
C ₁	Capacitor	0.1 μF
C ₂	Capacitor	0.1 μF
C ₃	Capacitor	0.1 μF
C ₄	Capacitor	0.1 μF
C ₅	Capacitor	0.1 μF
C _P	Capacitor	3.3 μF
RA ₁	Protection resistor	100 Ω
RA ₂	Protection resistor	100 Ω
IC ₁	Serial EEPROM	*

*: See "Serial EEPROM"

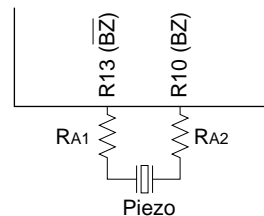

When the piezoelectric buzzer is driven directly

Note: The above tables are simply an example, and are not guaranteed to work.

S1C60R08 (Target for S1C60A08)

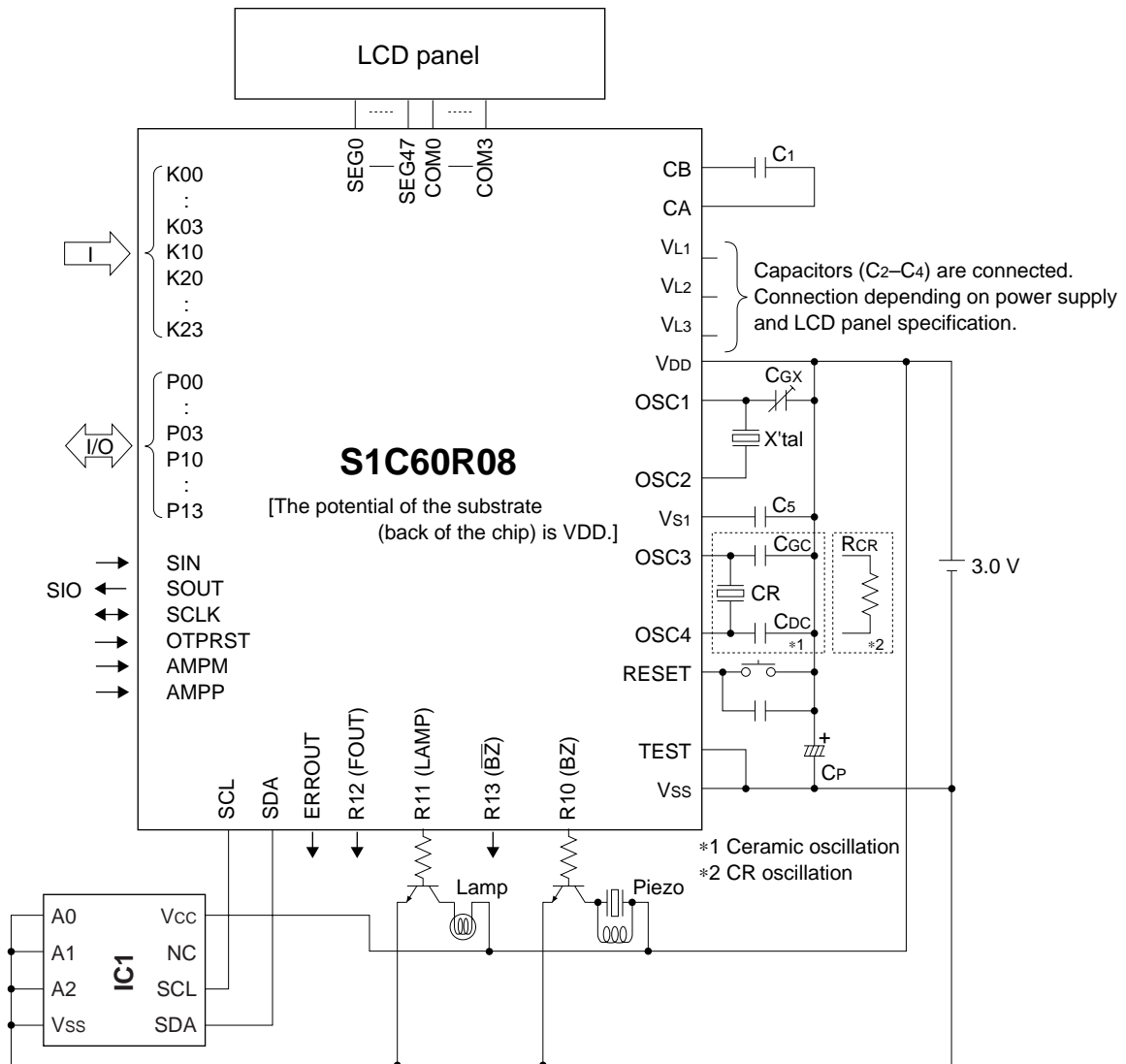

X'tal	Crystal oscillator	32.768 kHz or 38.400 kHz
CGX	Trimmer capacitor	5–25 pF
CR	Ceramic oscillator	500 kHz
CGC	Gate capacitor	100 pF
CDC	Drain capacitor	100 pF
RCR	Resistor for CR oscillation	82 kΩ
C1	Capacitor	0.1 μF
C2	Capacitor	0.1 μF
C3	Capacitor	0.1 μF
C4	Capacitor	0.1 μF
C5	Capacitor	0.1 μF
CP	Capacitor	3.3 μF
RA1	Protection resistor	100 Ω
RA2	Protection resistor	100 Ω
IC1	Serial EEPROM	*

*: See "Serial EEPROM"

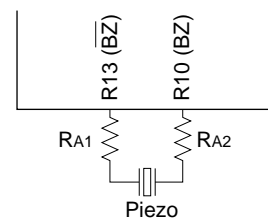

When the piezoelectric buzzer is driven directly

Note: The above tables are simply an example, and are not guaranteed to work.

S1C60N08/60R08

PACKAGE

Plastic QFP5-100pin

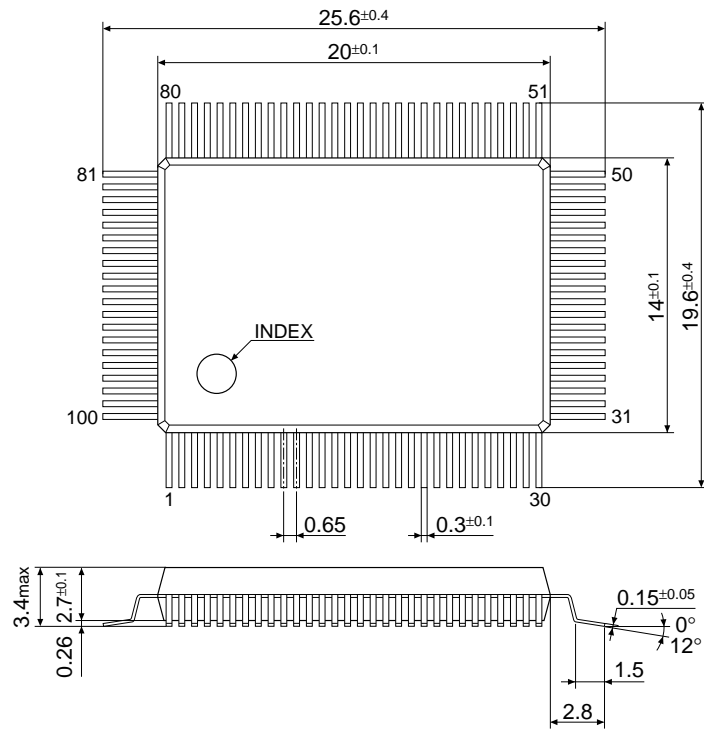

Plastic QFP15-100pin

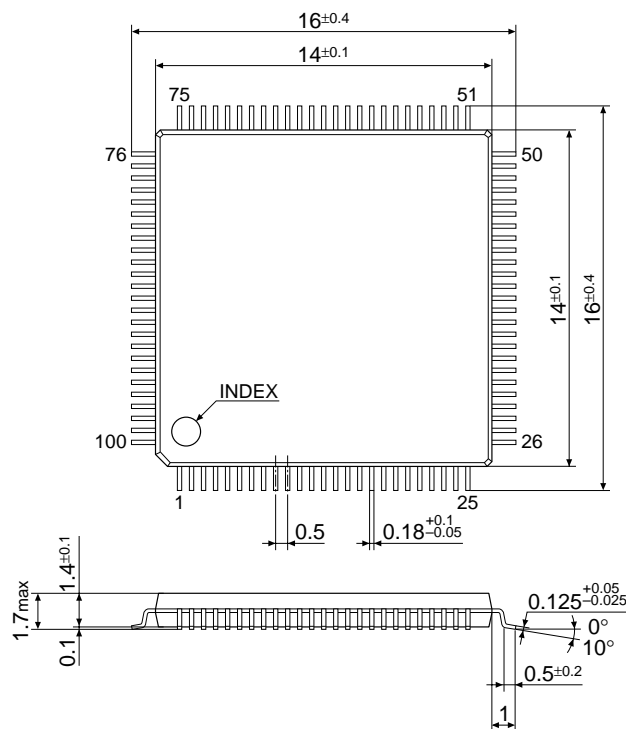

Unit: mm

■ PAD LAYOUT

● S1C60N08/60L08/60A08 Diagram of Pad Layout

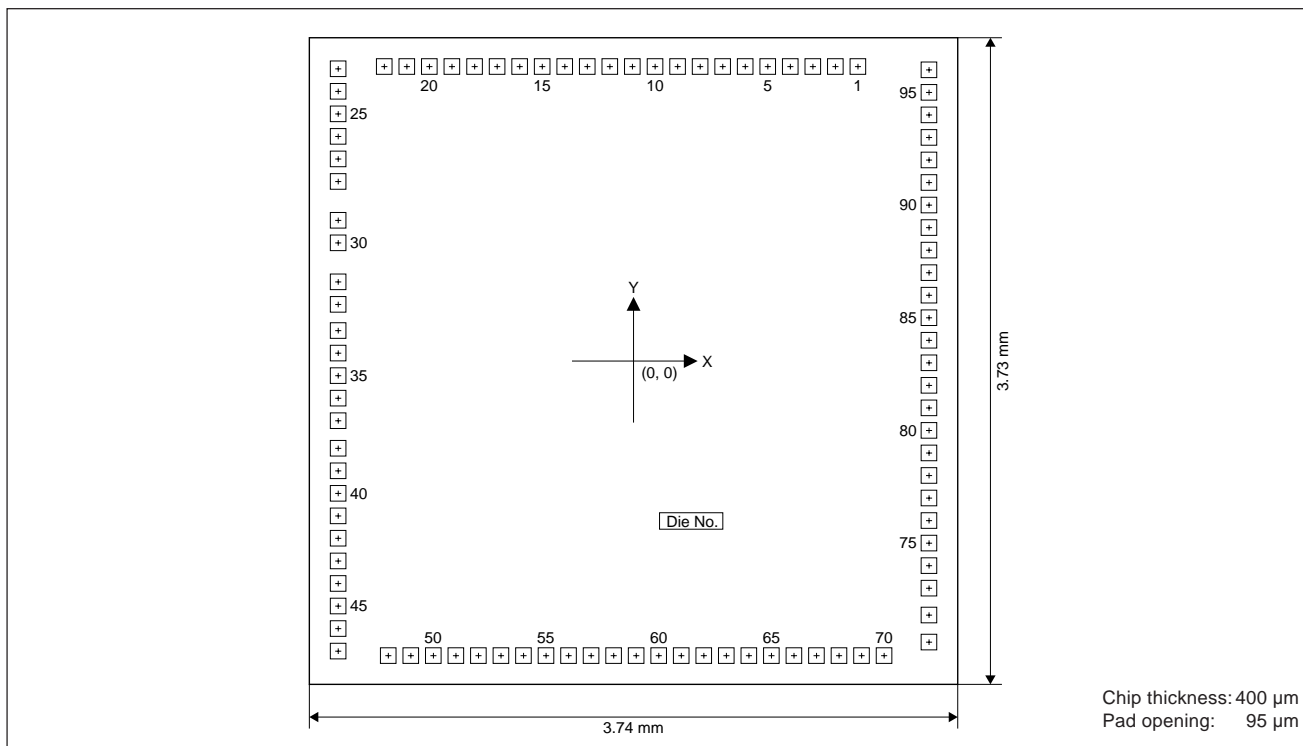

● S1C60N08/60L08/60A08 Pad Coordinates

Unit: μm

No.	Pad name	X	Y	No.	Pad name	X	Y	No.	Pad name	X	Y
1	AMPP	1,294	1,699	33	OSC4 *	-1,704	176	65	SEG30	795	-1,699
2	AMPM	1,164	1,699	34	OSC3 *	-1,704	46	66	SEG29	925	-1,699
3	K23	1,034	1,699	35	Vs1	-1,704	-84	67	SEG28	1,055	-1,699
4	K22	904	1,699	36	OSC2	-1,704	-214	68	SEG27	1,185	-1,699
5	K21	774	1,699	37	OSC1	-1,704	-344	69	SEG26	1,315	-1,699
6	K20	644	1,699	38	VDD	-1,704	-503	70	SEG25	1,445	-1,699
7	K10	514	1,699	39	VL3	-1,704	-633	71	SEG24	1,704	-1,621
8	K03	384	1,699	40	VL2	-1,704	-763	72	TEST	1,704	-1,465
9	K02	254	1,699	41	VL1	-1,704	-893	73	SEG23	1,704	-1,310
10	K01	124	1,699	42	CA	-1,704	-1,022	74	SEG22	1,704	-1,180
11	K00	-7	1,699	43	CB	-1,704	-1,153	75	SEG21	1,704	-1,050
12	SIN	-137	1,699	44	COM3	-1,704	-1,283	76	SEG20	1,704	-920
13	SOUT	-267	1,699	45	COM2	-1,704	-1,413	77	SEG19	1,704	-790
14	SCLK	-397	1,699	46	COM1	-1,704	-1,543	78	SEG18	1,704	-660
15	P03	-527	1,699	47	COM0	-1,704	-1,673	79	SEG17	1,704	-530
16	P02	-657	1,699	48	SEG47	-1,415	-1,699	80	SEG16	1,704	-400
17	P01	-787	1,699	49	SEG46	-1,285	-1,699	81	SEG15	1,704	-270
18	P00	-917	1,699	50	SEG45	-1,155	-1,699	82	SEG14	1,704	-140
19	P13	-1,048	1,699	51	SEG44	-1,025	-1,699	83	SEG13	1,704	-10
20	P12	-1,178	1,699	52	SEG43	-895	-1,699	84	SEG12	1,704	120
21	P11	-1,308	1,699	53	SEG42	-765	-1,699	85	SEG11	1,704	250
22	P10	-1,438	1,699	54	SEG41	-635	-1,699	86	SEG10	1,704	380
23	R03	-1,704	1,686	55	SEG40	-505	-1,699	87	SEG9	1,704	510
24	R02	-1,704	1,556	56	SEG39	-375	-1,699	88	SEG8	1,704	640
25	R01	-1,704	1,426	57	SEG38	-245	-1,699	89	SEG7	1,704	770
26	R00	-1,704	1,296	58	SEG37	-115	-1,699	90	SEG6	1,704	900
27	R12	-1,704	1,166	59	SEG36	15	-1,699	91	SEG5	1,704	1,030
28	R11	-1,704	1,036	60	SEG35	145	-1,699	92	SEG4	1,704	1,160
29	R10	-1,704	812	61	SEG34	275	-1,699	93	SEG3	1,704	1,290
30	R13	-1,704	682	62	SEG33	405	-1,699	94	SEG2	1,704	1,420
31	Vss	-1,704	457	63	SEG32	535	-1,699	95	SEG1	1,704	1,550
32	RESET	-1,704	327	64	SEG31	665	-1,699	96	SEG0	1,704	1,680

*: S1C60A08 only

S1C60N08/60R08

● S1C60R08 Diagram of Pad Layout

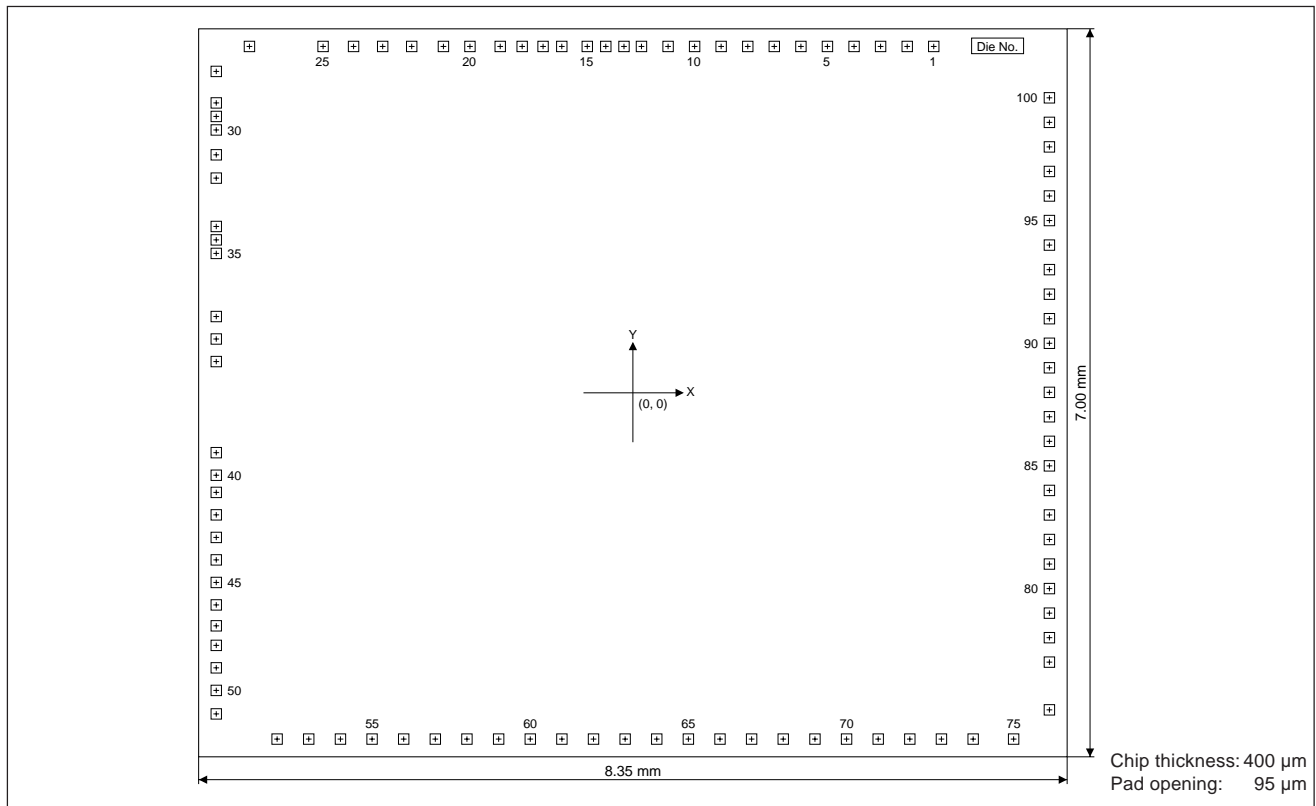

● S1C60R08 Pad Coordinates

Unit: μm

No.	Pad name	X	Y	No.	Pad name	X	Y	No.	Pad name	X	Y
1	AMPP	2,893	3,330	35	REST	-4,005	1,340	69	SEG30	1,751	-3,330
2	AMPM	2,638	3,330	36	OSC4	-4,005	733	70	SEG29	2,055	-3,330
3	K23	2,382	3,330	37	OSC3	-4,005	517	71	SEG28	2,359	-3,330
4	K22	2,127	3,330	38	Vs1	-4,005	300	72	SEG27	2,663	-3,330
5	K21	1,871	3,330	39	OSC2	-4,005	-576	73	SEG26	2,967	-3,330
6	K20	1,616	3,330	40	OSC1	-4,005	-793	74	SEG25	3,272	-3,330
7	K10	1,360	3,330	41	VDD	-4,005	-958	75	SEG24	3,661	-3,330
8	K03	1,105	3,330	42	VL3	-4,005	-1,174	76	TEST	4,005	-3,049
9	K02	849	3,330	43	VL2	-4,005	-1,391	77	SEG23	4,005	-2,590
10	K01	594	3,330	44	VL1	-4,005	-1,607	78	SEG22	4,005	-2,355
11	K00	339	3,330	45	CA	-4,005	-1,824	79	SEG21	4,005	-2,119
12	SIN	83	3,330	46	CB	-4,005	-2,040	80	SEG20	4,005	-1,883
13	SOUT	-85	3,330	47	ERROUT	-4,005	-2,241	81	SEG19	4,005	-1,647
14	OTPRST	-260	3,330	48	COM3	-4,005	-2,429	82	SEG18	4,005	-1,411
15	SCLK	-438	3,330	49	COM2	-4,005	-2,645	83	SEG17	4,005	-1,175
16	P03	-683	3,330	50	COM1	-4,005	-2,862	84	SEG16	4,005	-939
17	P02	-863	3,330	51	COM0	-4,005	-3,088	85	SEG15	4,005	-703
18	P01	-1,064	3,330	52	SEG47	-3,420	-3,330	86	SEG14	4,005	-467
19	P00	-1,275	3,330	53	SEG46	-3,116	-3,330	87	SEG13	4,005	-231
20	SCL	-1,566	3,330	54	SEG45	-2,811	-3,330	88	SEG12	4,005	4
21	SDA	-1,821	3,330	55	SEG44	-2,507	-3,330	89	SEG11	4,005	240
22	P13	-2,126	3,330	56	SEG43	-2,203	-3,330	90	SEG10	4,005	476
23	P12	-2,405	3,330	57	SEG42	-1,899	-3,330	91	SEG9	4,005	712
24	P11	-2,685	3,330	58	SEG41	-1,595	-3,330	92	SEG8	4,005	948
25	P10	-2,978	3,330	59	SEG40	-1,290	-3,330	93	SEG7	4,005	1,184
26	R03	-3,686	3,330	60	SEG39	-986	-3,330	94	SEG6	4,005	1,420
27	R02	-4,005	3,090	61	SEG38	-682	-3,330	95	SEG5	4,005	1,656
28	R01	-4,005	2,787	62	SEG37	-378	-3,330	96	SEG4	4,005	1,892
29	R00	-4,005	2,657	63	SEG36	-74	-3,330	97	SEG3	4,005	2,128
30	R12	-4,005	2,527	64	SEG35	230	-3,330	98	SEG2	4,005	2,364
31	R11	-4,005	2,288	65	SEG34	534	-3,330	99	SEG1	4,005	2,600
32	R10	-4,005	2,064	66	SEG33	838	-3,330	100	SEG0	4,005	2,836
33	R13	-4,005	1,599	67	SEG32	1,142	-3,330				
34	Vss	-4,005	1,470	68	SEG31	1,446	-3,330				

THIS PAGE IS BLANK.

S1C60N08/60R08

NOTICE:

No part of this material may be reproduced or duplicated in any form or by any means without the written permission of Seiko Epson. Seiko Epson reserves the right to make changes to this material without notice. Seiko Epson does not assume any liability of any kind arising out of any inaccuracies contained in this material or due to its application or use in any product or circuit and, further, there is no representation that this material is applicable to products requiring high level reliability, such as, medical products. Moreover, no license to any intellectual property rights is granted by implication or otherwise, and there is no representation or warranty that anything made in accordance with this material will be free from any patent or copyright infringement of a third party. This material or portions thereof may contain technology or the subject relating to strategic products under the control of the Foreign Exchange and Foreign Trade Law of Japan and may require an export license from the Ministry of International Trade and Industry or other approval from another government agency.

© Seiko Epson Corporation 2001 All right reserved.

SEIKO EPSON CORPORATION

ELECTRONIC DEVICES MARKETING DIVISION

IC Marketing & Engineering Group

ED International Marketing Department Europe & U.S.A.

421-8, Hino, Hino-shi, Tokyo 191-8501, JAPAN
Phone : 042-587-5812 FAX : 042-587-5564

ED International Marketing Department Asia

421-8, Hino, Hino-shi, Tokyo 191-8501, JAPAN
Phone : 042-587-5814 FAX : 042-587-5110

■ EPSON Electronic Devices Website

<http://www.epson.co.jp/device/>