

SR1080 THRU SR10100



10 AMP SCHOTTKY BARRIER RECTIFIERS



FEATURES

- * Low forward voltage drop
- * High current capability
- * High reliability
- * High surge current capability
- * Epitaxial construction

MECHANICAL DATA

- * Case: Molded plastic
- * Epoxy: UL 94V-0 rate flame retardant
- * Lead: Lead solderable per MIL-STD-202, method 208 guaranteed
- * Polarity: As Marked
- * Mounting position: Any
- * Weight: 2.24 grams

VOLTAGE RANGE

80 to 100 Volts

CURRENT

10 Ampere

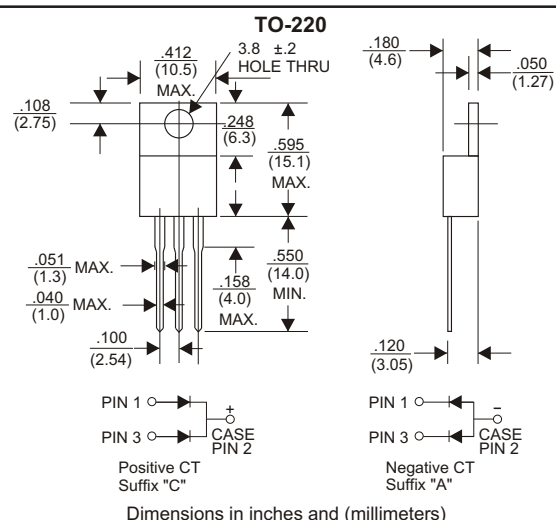

MAXIMUM RATINGS AND ELECTRICAL CHARACTERISTICS

Rating 25°C ambient temperature unless otherwise specified.
Single phase half wave, 60Hz, resistive or inductive load.
For capacitive load, derate current by 20%.

TYPE NUMBER	SR1080	SR10100	UNITS
Maximum Recurrent Peak Reverse Voltage	80	100	V
Maximum RMS Voltage	56	70	V
Maximum DC Blocking Voltage	80	100	V
Maximum Average Forward Rectified Current			
.375"(9.5mm) Lead Length at Tc=100°C	10		A
Peak Forward Surge Current, 8.3 ms single half sine-wave superimposed on rated load (JEDEC method)	120		A
Maximum Instantaneous Forward Voltage at 5A	0.85		V
Maximum DC Reverse Current Ta=25°C	0.1		mA
at Rated DC Blocking Voltage Ta=125°C	15		mA
Typical Junction Capacitance (Note1)	300		pF
Typical Thermal Resistance R JA (Note 2)	3.0		°C/W
Operating Temperature Range Tj	-55 — +150		°C
Storage Temperature Range Tstg	-55 — +175		°C

NOTES:

1. Measured at 1MHz and applied reverse voltage of 4.0V D.C.
2. Thermal Resistance Junction to Ambient Vertical PC Board Mounting 0.5"(12.7mm) Lead Length.

RATING AND CHARACTERISTIC CURVES (SR1080 THRU SR10100)

FIG.1-TYPICAL FORWARD CURRENT DERATING CURVE

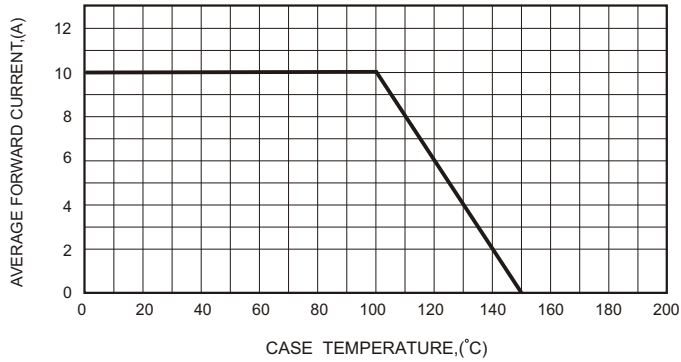

FIG.2-TYPICAL FORWARD CHARACTERISTICS

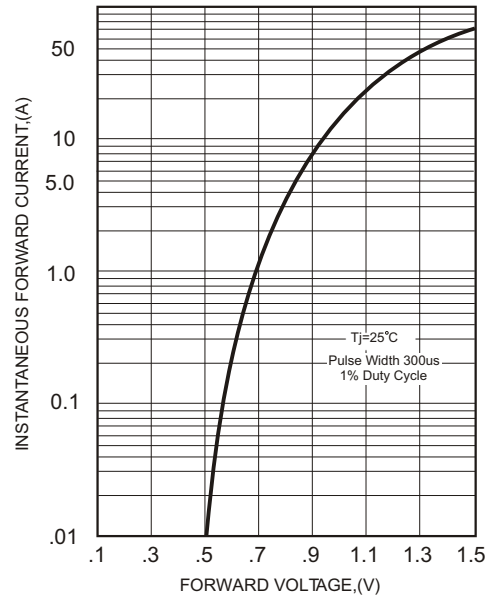

FIG.3-MAXIMUM NON-REPETITIVE FORWARD SURGE CURRENT

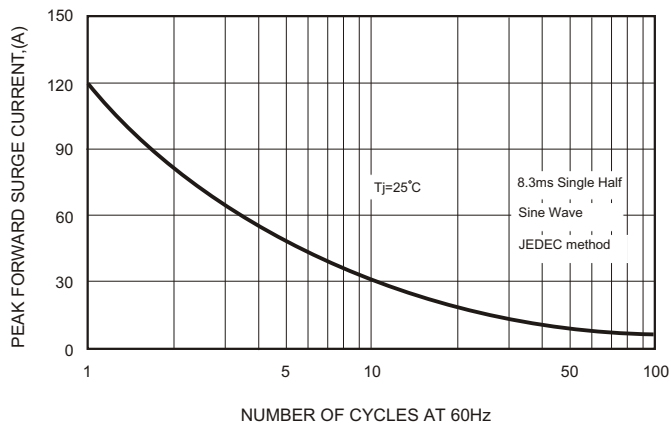

FIG.4-TYPICAL JUNCTION CAPACITANCE

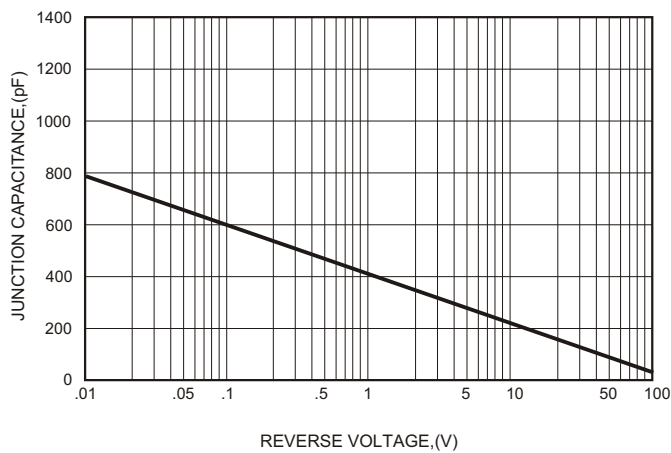

FIG.5 - TYPICAL REVERSE CHARACTERISTICS

