

2-Bit Level Shifting Buffer/Transceiver with Configurable Dual Supply Voltage

Features

- Operation Voltage: $1.65V \leq V_{CCA} \leq 3.6V$
 $2.3V \leq V_{CCB} \leq 5.5V$
 $V_{CCA} \leq V_{CCB}$
- High Speed: $t_{pd} = 5ns$ typical into $30pF$ @ $3V V_{CC}$
- Power down high-impedance inputs and outputs
- High output drive: $\pm 12mA$ at $3V V_{CCA}/V_{CCB}$
 $\pm 24mA$ at $5V V_{CCB}$
- Industrial operation at $-40^{\circ}C$ to $+85^{\circ}C$
- Packaging (Pb-free & Green available):
 - 8-pin MSOP (U)
 - 12-pin TDFN (ZE)

Description

Pericom Semiconductor's PI74STX2G4245, a 2-bit noninverting buffer/transceiver, contains two separate supply rails: A port (V_{CCA}), set to operate from 1.8V to 3.3V; B port (V_{CCB}), set to operate from 2.5V to 5V. The A1 to B1 translation is configured as an unidirectional buffer; the translation between A2 and B2 is bidirectional and its direction is controlled by the DIR pin. The DIR pin is supplied by V_{CCB} .

Block Diagram

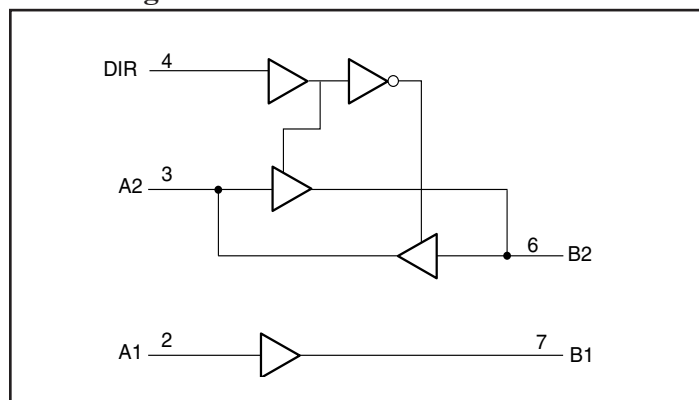

Pin Configuration (MSOP)

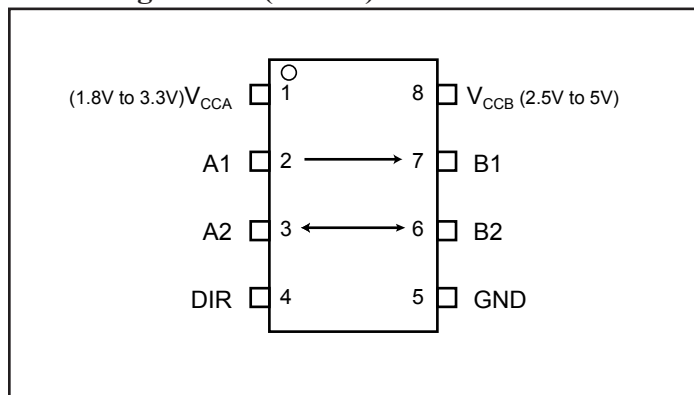

Function Table

Input		Output
DIR	DATA	
L	B2	A2
H	A2	B2
X	A1	B1

Pin Description

Pin Name	Description
DIR	Direction Control
A1	Data Input
B1	Data Output
A2, B2	Data Input/Output
V_{CCA}, V_{CCB}	Power Supply

Pin Configuration (TDFN)

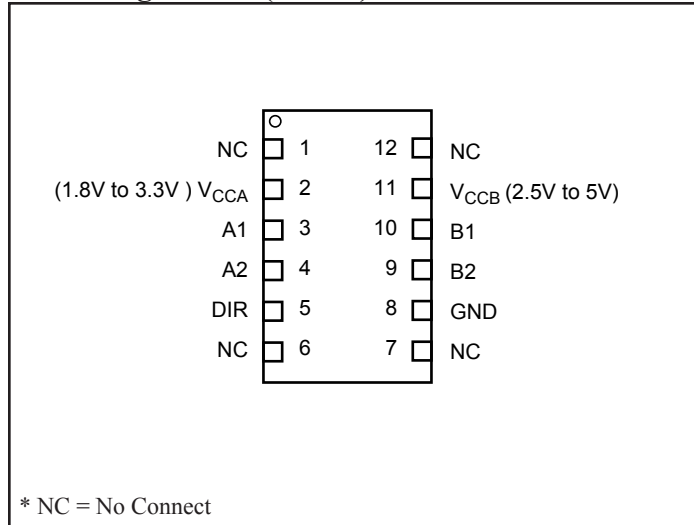

Maximum Ratings

(Absolute maximum ratings over operating free-air temperature range from V_{CCB} at 2.5V & V_{CCA} at 1.2V, unless otherwise noted)

Supply voltage range: V_{CCA} -0.5V to +6V	DC Input Diode Current, I_{IK} ($V_O < 0$)..... -50mA
V_{CCB} -0.5V to +6V	DC Output Diode Current, I_{OK} ($V_O < 0$)..... -50mA
Input Voltage Range, V_I :	DC Output Current, (I_{OUT}) ± 50 mA
Input A1 ⁽¹⁾ -0.5V to +6V	DC V_{CC} or GND Current (I_{CC}/I_{GND})..... ± 100 mA
I/O A2 ^(1,2) -0.5V to $V_{CCA}+0.5$ V	Storage temperature range, T_{STG} -65°C to 150°C
I/O B2 ^(1,2) -0.5V to $V_{CCB}+0.5$ V	Junction Lead Temperature (I_{OS}) 260°C
Output Voltage Range, V_O	Power Dissipation: MSOP 200mW
Output B1 ^(1,2) ... -0.5V to $V_{CCB} +0.5$ V	

Notes:

Stresses greater than those listed under MAXIMUM RATINGS may cause permanent damage to the device. This is a stress rating only and functional operation of the device at these or any other conditions above those indicated in the operational sections of this specification is not implied. Exposure to absolute maximum rating conditions for extended periods may affect reliability.

1. The input negative voltage and output voltage ratings may be exceeded if the input and output current ratings are observed.
2. This value is limited to 6V.

Recommended Operating Conditions for A Port (V_{CCA})⁽¹⁾

Parameter	Description	Test Conditions	Min.	Max.	Units
V_{CCA}	Supply Voltage		1.65	3.6	V
V_{IH}	High-level input voltage	$V_{CCA} = 1.65$ V to 1.95V	$0.7 \times V_{CCA}$		
		$V_{CCA} = 2.3$ V to 3.6V	$0.7 \times V_{CCA}$		
V_{IL}	Low-level input voltage	$V_{CCA} = 1.65$ to 1.95V		$0.3 \times V_{CCA}$	
		$V_{CCA} = 2.3$ V to 3.6V		$0.3 \times V_{CCA}$	
V_{IA}	Input Voltage		0	V_{CCA}	
V_{OA}	Output Voltage		0	V_{CCA}	
I_{OH}	High-level Output Current	$V_{CCA} = 1.65$ V to 1.95V		-4	mA
		$V_{CCA} = 2.3$ V to 2.7V		-8	
		$V_{CCA} = 3$ V to 3.6V		-12	
I_{OL}	Low-level Output Current	$V_{CCA} = 1.65$ V to 1.95V		4	
		$V_{CCA} = 2.3$ V to 2.7V		8	
		$V_{CCA} = 3$ V to 3.6V		12	
$\Delta t/\Delta V$	Input transition rise or fall rate	$V_{CCA} = 1.65$ V to 1.95V		20	ns/V
		$V_{CCA} = 2.3$ V to 3.6V		10	
T_A	Operation free-air temperature		-40	85	°C

Notes:

1. To ensure proper device operation, all unused inputs must be held at V_{CCA} or GND.

Recommended Operating Conditions for B Port (V_{CCB})⁽¹⁾

Parameters	Description	Test Conditions	Min.	Max.	Units
V_{CCB}	Supply Voltage		2.3	5.5	V
V_{IH}	High-level input voltage	Data Inputs	$V_{CCB} = 2.3V$ to $5.5V$	$0.7 \times V_{CCB}$	
		DIR pin			
V_{IL}	Low-level input voltage	Data Inputs	$V_{CCB} = 2.3V$ to $5.5V$	$0.3 \times V_{CCB}$	
		DIR pin			
V_{IB}	Input Voltage		0	V_{CCB}	
V_{OB}	Output Voltage		0	V_{CCB}	
I_{OH}	High-level Output Current	$V_{CCB} = 2.3V$ to $2.7V$		-8	mA
		$V_{CCB} = 3V$ to $3.6V$		-12	
		$V_{CCB} = 4.5V$ to $5.5V$		-24	
I_{OL}	Low-level Output Current	$V_{CCB} = 2.3V$ to $2.7V$		8	
		$V_{CCB} = 3V$ to $3.6V$		12	
		$V_{CCB} = 4.5V$ to $5.5V$		24	
$\Delta t/\Delta V$	Input transition rise or fall rate	$V_{CCB} = 2.3V$ to $5.5V$		10	m/V
T_A	Operation free-air temperature		-40	85	°C

Notes:

- To ensure proper device operation, all unused inputs must be held at V_{CCB} or GND.

Electrical Characteristics (Over recommended operating free-air temperature range)

Parameters		Test Conditions	$V_{CCA}^{(1)}$	$V_{CCB}^{(1)}$	Min.	Typ. ⁽²⁾	Max.	Units	
V_{OHA} (B to A)		$I_{OH} = -100\mu A$	1.65V to 3.6V	$2.3V \leq V_{CCB} \leq 5.5V$ and $V_{CCB} \geq V_{CCA}$	$V_{CCB}-0.1$			V	
		$I_{OH} = -4mA$	1.65V		1.3				
		$I_{OH} = -8mA$	2.3V		1.8				
		$I_{OH} = -12mA$	3.0V		2.4				
V_{OLA} (B to A)		$I_{OH} = 100\mu A$	1.65V to 3.6V						0.1
		$I_{OH} = 4mA$	1.65V						0.24
		$I_{OH} = 8mA$	2.3V						0.3
		$I_{OH} = 12mA$	3.0V						0.4
V_{OHB} (A to B)		$I_{OH} = -100\mu A$	$1.65V \leq V_{CCA} \leq 3.6V$ and $V_{CCB} \geq V_{CCA}$	2.3V to 5.5V	$V_{CCB}-0.1$				
		$I_{OH} = -8mA$		2.3V	1.8				
		$I_{OH} = -12mA$		3.0V	2.4				
		$I_{OH} = -24mA$		4.5V	3.8				
V_{OLB} (A to B)		$I_{OH} = 100\mu A$			2.3V to 5.5V			0.1	
		$I_{OH} = 8mA$			2.3V			0.3	
		$I_{OH} = 12mA$			3.0V			0.4	
		$I_{OH} = 24mA$			4.5V			0.55	
$I_I^{(3)}$	$V_I = V_{CCA}/V_{CCB}$ or GND	1.65V to 3.6V and $V_{CCB} \geq V_{CCA}$	2.3V to 5.5V and $V_{CCB} \geq V_{CCA}$				± 5	μA	
I_{OFF}	V_I or $V_O = V_{CCB}$ or GND	0V	0 to 5.5V				± 10		
	V_I or $V_O = V_{CCA}$ or GND	0 to 3.6V	0V				± 10		
I_{CCA}	$V_I = V_{CCA}$ or GND, $I_O = 0$	1.65V to 3.6V and $V_{CCB} \geq V_{CCA}$	2.3 to 5.5V and $V_{CCB} \geq V_{CCA}$				10		
I_{CCB}	$V_I = V_{CCB}$ or GND, $I_O = 0$							10	
C_I	A1, DIR	$V_I = V_{CCA}$ or GND	1.8V	3.3V		4.5		pF	
C_O	B1	$V_O = V_{CCB}$ or GND	1.8V	3.3V		4.5			
C_{IO}	A2, B2	V_I or $V_O = V_{CCA}/V_{CCB}$ or GND	1.8V	3.3V		6.0			

Notes:

- When $1.65 \leq V_{CCA} \leq 1.95V$, V_{CCB} can not be greater than 3.6V
- All Typical values are at $T_A = 25^\circ C$
- For I/O ports, the parameter I_I includes the output leakage current.

Switching Characteristics for $V_{CCA} = 1.8V \pm 0.15V$

(Over recommended operating free-air temperature range, see figure 1)

Parameter	From (Input)	To (Output)	$V_{CCB} = 2.5V \pm 0.2V$		$V_{CCB} = 3.3V \pm 0.3V$		Units
			Min.	Max.	Min.	Max.	
t_{PHL}	A	B	1.0	8	1.0	8	ns
t_{PLH}			1.0	8	1.0	8	
t_{PHL}	B	A	1.0	7	1.0	7	
t_{PLH}			1.0	7	1.0	7	
$t_{SK(O)}$				1.5		1	

Switching Characteristics for $V_{CCA} = 2.5V \pm 0.2V$

(Over recommended operating free-air temperature range, see figure 1)

Parameter	From (Input)	To (Output)	$V_{CCB} = 2.5V \pm 0.2V$		$V_{CCB} = 3.3V \pm 0.3V$		$V_{CCB} = 5V \pm 0.5V$		Units
			Min.	Max.	Min.	Max.	Min.	Max.	
t_{PHL}	A	B	1.0	7	1.0	6.5	1.0	6	ns
t_{PLH}			1.0	7	1.0	6.5	1.0	6	
t_{PHL}	B	A	1.0	6	1.0	6	1.0	5	
t_{PLH}			1.0	6	1.0	6	1.0	5	
$t_{SK(O)}$				1.5		1		1	

Switching Characteristics for $V_{CCA} = 3.3V \pm 0.3V$

(Over recommended operating free-air temperature range, see figure 1)

Parameter	From (Input)	To (Output)	$V_{CCB} = 3.3V \pm 0.3V$		$V_{CCB} = 5V \pm 0.5V$		Units
			Min.	Max.	Min.	Max.	
t_{PHL}	A	B	1.0	5	1.0	5	ns
t_{PLH}			1.0	5	1.0	5	
t_{PHL}	B	A	1.0	5	1.0	5	
t_{PLH}			1.0	5	1.0	5	
$t_{SK(O)}$				1		1	

AC Loading and Waveforms

$V_{CCA/B}$	C_L	R_L
$1.8 \pm 0.15V$	15pF	1K Ω
$2.5V \pm 0.2V$	15pF	500 Ω
3.0V to 3.6V	30pF	500 Ω
$5V \pm 0.5V$	50pF	500 Ω

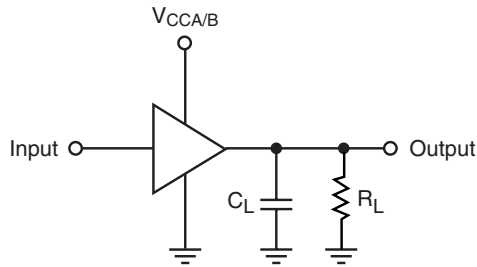

C_L includes load and stray capacitance
 Input PRR = 1.0 MHz; $t_W = 500ns$

Figure 1. AC Test Circuit

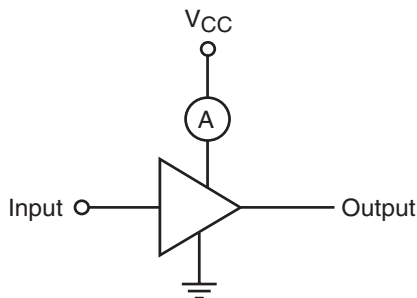

Input = AC Waveform; $t_r = t_f = 1.8ns$;
 PRR = 10 MHz; Duty Cycle = 50%

Figure 2. ICCD Test Circuit

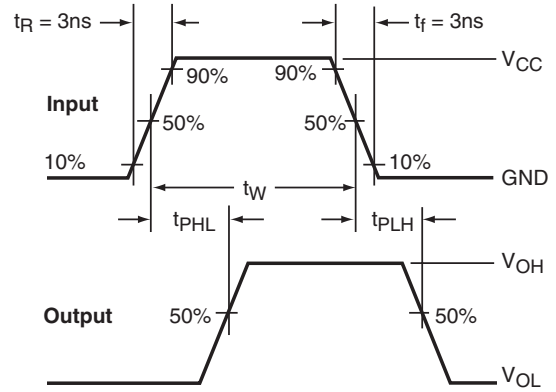
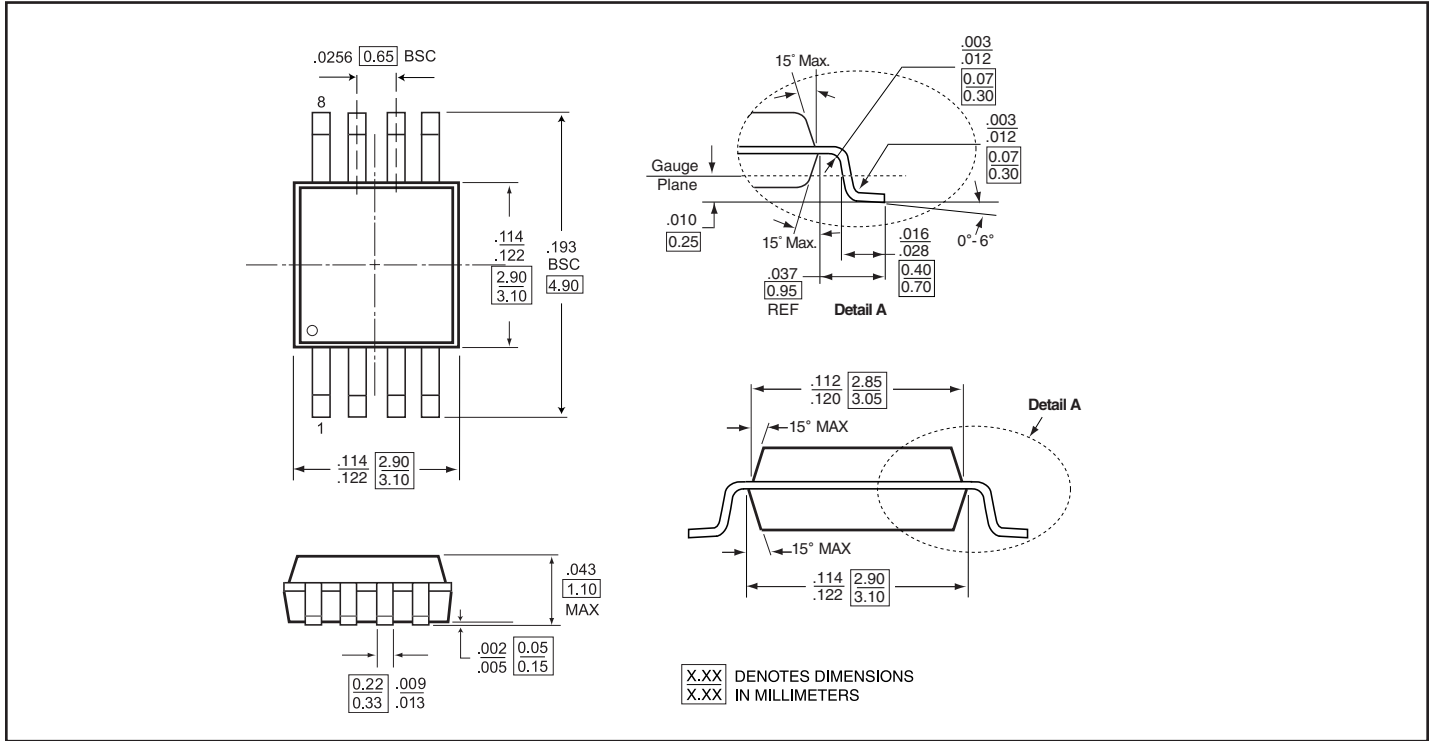
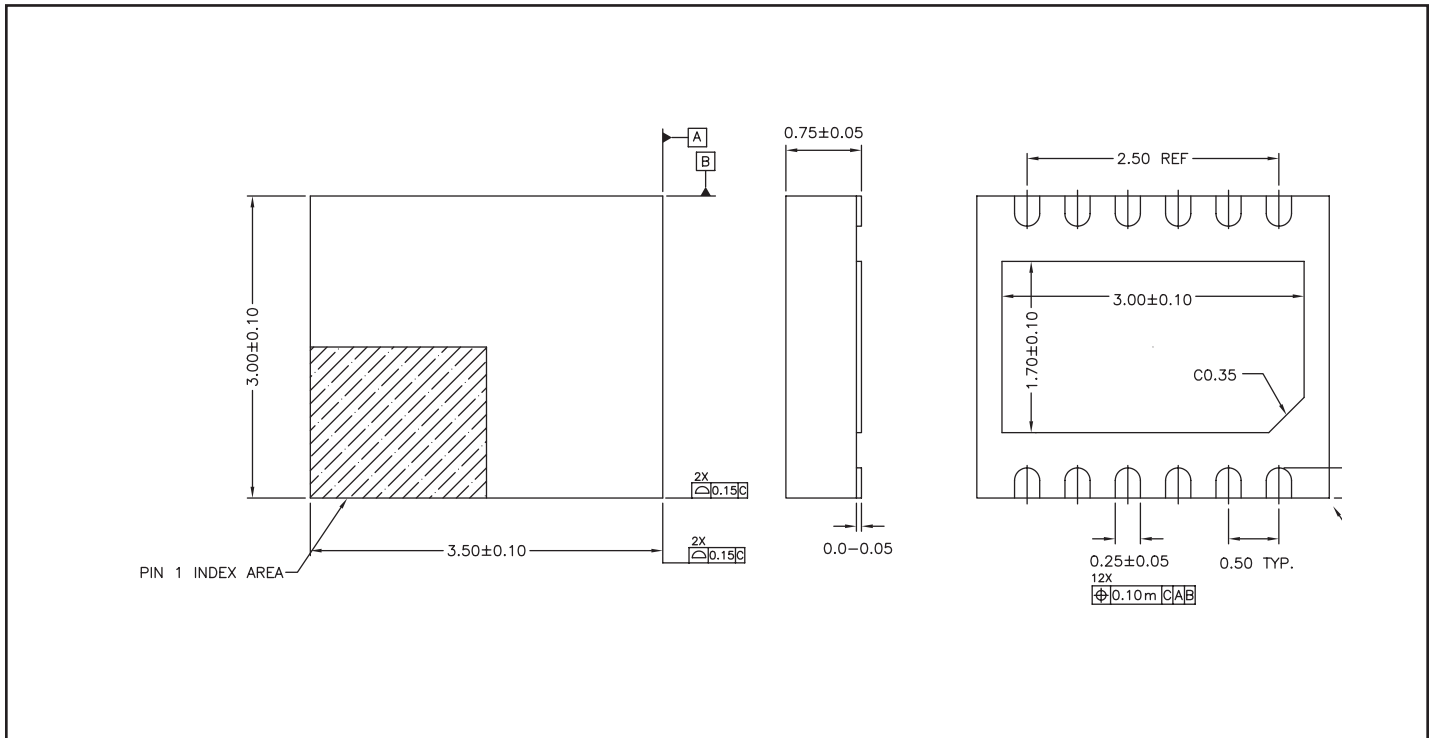

Figure 3. AC Waveforms

Packaging Mechanical: 8-Pin MSOP (U)



Packaging Mechanical: 12-pin TDFN (ZE)



Ordering Information

Ordering Code	Package Code	Package Type	Package Top Marking
PI74STX2G4245UX	U	8-pin MSOP	DE
PI74STX2G4245UEX	U	Pb-free & Green, 8-pin MSOP	$\overline{\text{DE}}$
PI74STX2G4245ZEEX	ZE	Pb-free & Green, 12-pin TDFN	$\overline{\text{DE}}$

Notes:

- Thermal characteristics can be found on the company web site at www.pericom.com/packaging/
- E = Pb-free & Green
- X suffix = Tape/Reel