



# TAI-SAW TECHNOLOGY CO., LTD.

No. 3, Industrial 2nd Rd., Ping-Chen Industrial District,  
Taoyuan, 324, Taiwan, R.O.C.

TEL: 886-3-4690038 FAX: 886-3-4697532

E-mail: [tstsales@mail.taisaw.com](mailto:tstsales@mail.taisaw.com) Web: [www.taisaw.com](http://www.taisaw.com)

## Approval Sheet For Product Specification

Issued Date:

Product Name: SAW Filter 467.5375MHz SMD3.8X3.8mm

TST Parts No.: TA0476A

Customer Parts No.: \_\_\_\_\_

Company: _____
Division: _____
Approved by : _____
Date: _____

Checked by: \_\_\_\_\_ Asin Lin

Approval by: \_\_\_\_\_ Francis Chen

Date: \_\_\_\_\_ 2005/7/04



# TAI-SAW TECHNOLOGY CO., LTD.

No. 3, Industrial 2nd Rd., Ping-Chen Industrial District,  
Taoyuan, 324, Taiwan, R.O.C.

TEL: 886-3-4690038 FAX: 886-3-4697532

E-mail: [tstsales@mail.taisaw.com](mailto:tstsales@mail.taisaw.com) Web: [www.taisaw.com](http://www.taisaw.com)

## SAW Filter 467.5375 MHz

MODEL NO.: TA0476A

REV. NO.:1

### A. MAXIMUM RATING:

1. Input Power Level: 0 dBm
2. DC voltage: 5 V
3. Operating Temperature: -40°C to +85°C
4. Storage Temperature: -40°C to +85°C

RoHS Compliant  
Lead free  
Lead-free soldering

### B. ELECTRICAL CHARACTERISTICS:

TA= -40°C to +85°C

Item	Min.	Typ.	Max.	Note
Center frequency $F_c$ (MHz)	-	467.5375	-	1
Minimum I.L. (dB) $IL_{min}$	-	3.1	4	
Pass band (relative to $IL_{min}$ ) 467.2875~467.7875 MHz (dB)	-	0.7	3	1
Pass bandwidth (relative to $IL_{min}$ ) $BW_3$ (KHz)	500	950	-	
Attenuation:( relative to $IL_{min}$ ) (dB )				
10~442.46 MHz (dB )	40	47	-	
442.46~453.26 MHz (dB )	40	44	-	
453.6~466.0 MHz (dB )	15	23	-	
469.2~478.6 MHz (dB )	10	16	-	
478.6~490.6 MHz (dB )	38	42	-	1
490.6~1000 MHz (dB )	40	45	-	

Note1. The standard definitions is in JIS C 6703

### C. FREQUENCY CHARACTERISTICS:

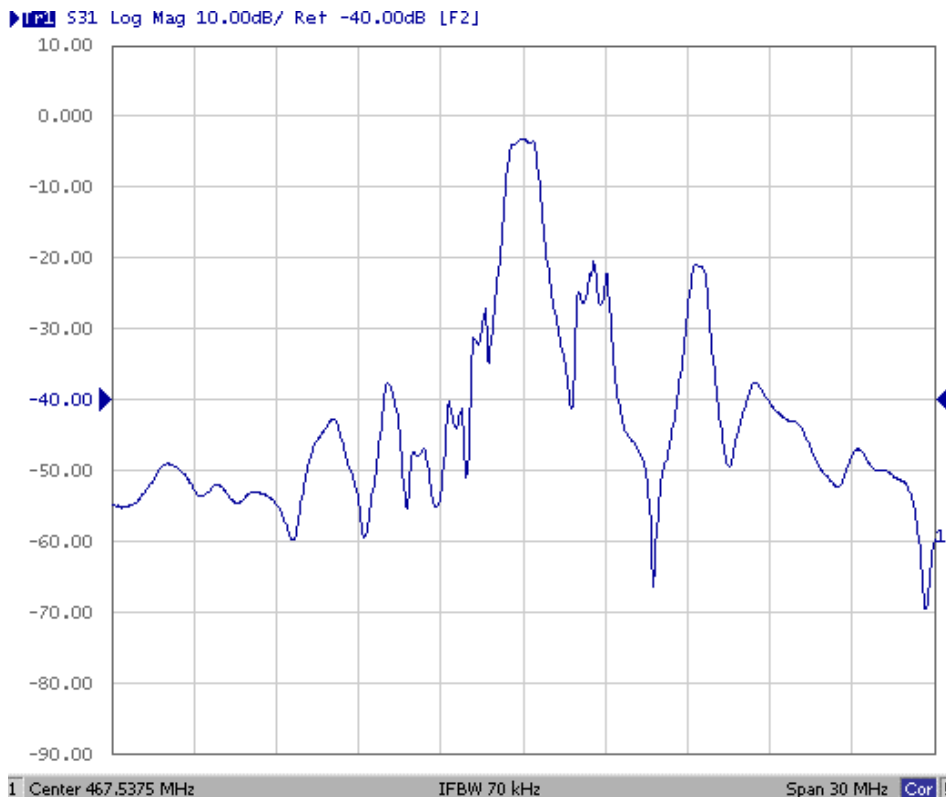

**D. MEASUREMENT CIRCUIT:**

HP Network analyzer

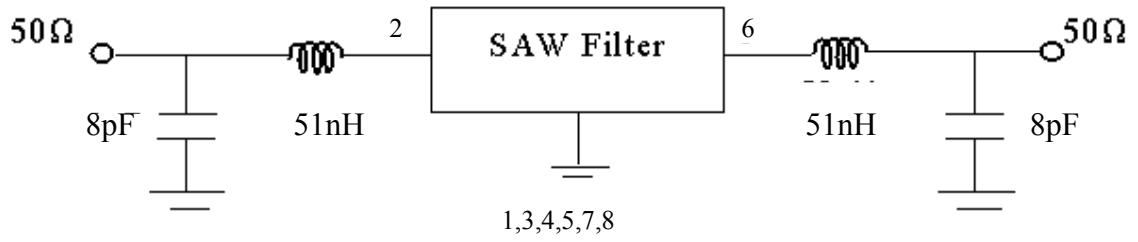

**E. OUTLINE DRAWING:**

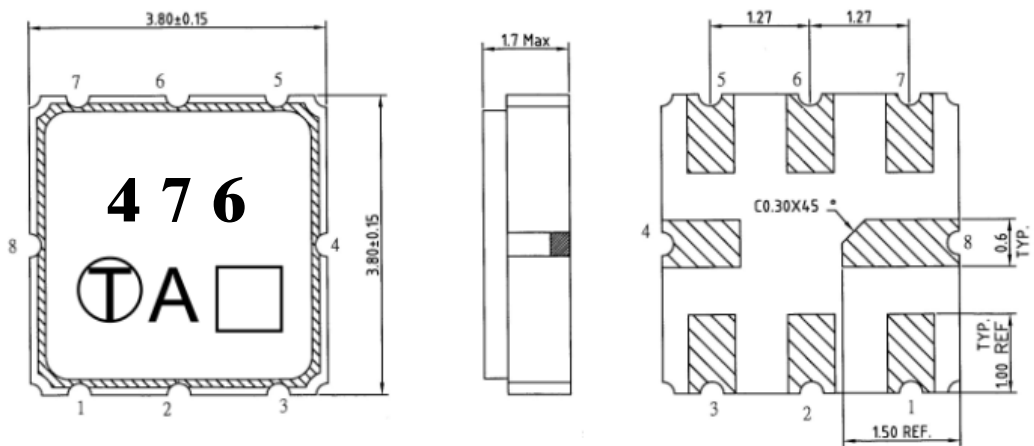

Pin2: Input  
 Pin6: Output  
 Pin1,3,4,5,7,8 to be ground  
 □ : Date code  
 Unit : mm

**F. PCB FOOTPRINT**

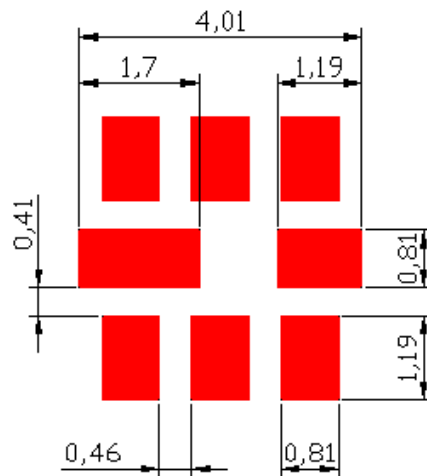

G. PACKING:

1. REEL DIMENSION

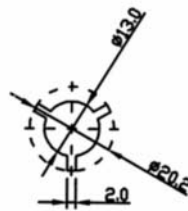
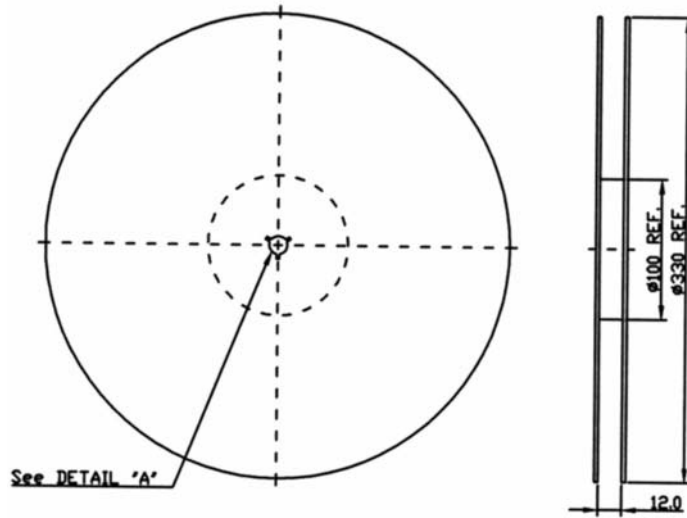

2. TAPE DIMENSION

