

isc Silicon NPN Power Transistor

2SD1544

DESCRIPTION

- High Breakdown Voltage-
: $V_{CBO}= 1500V$ (Min)
- High Switching Speed
- Low Saturation Voltage

APPLICATIONS

- Color TV horizontal output applications

ABSOLUTE MAXIMUM RATINGS($T_a=25^{\circ}C$)

SYMBOL	PARAMETER	VALUE	UNIT
V_{CBO}	Collector-Base Voltage	1500	V
V_{CEO}	Collector-Emitter Voltage	600	V
V_{EBO}	Emitter-Base Voltage	5	V
I_C	Collector Current- Continuous	3.5	A
I_B	Base Current- Continuous	1	A
P_C	Collector Power Dissipation @ $T_C=25^{\circ}C$	40	W
T_J	Junction Temperature	150	$^{\circ}C$
T_{stg}	Storage Temperature Range	-55~150	$^{\circ}C$

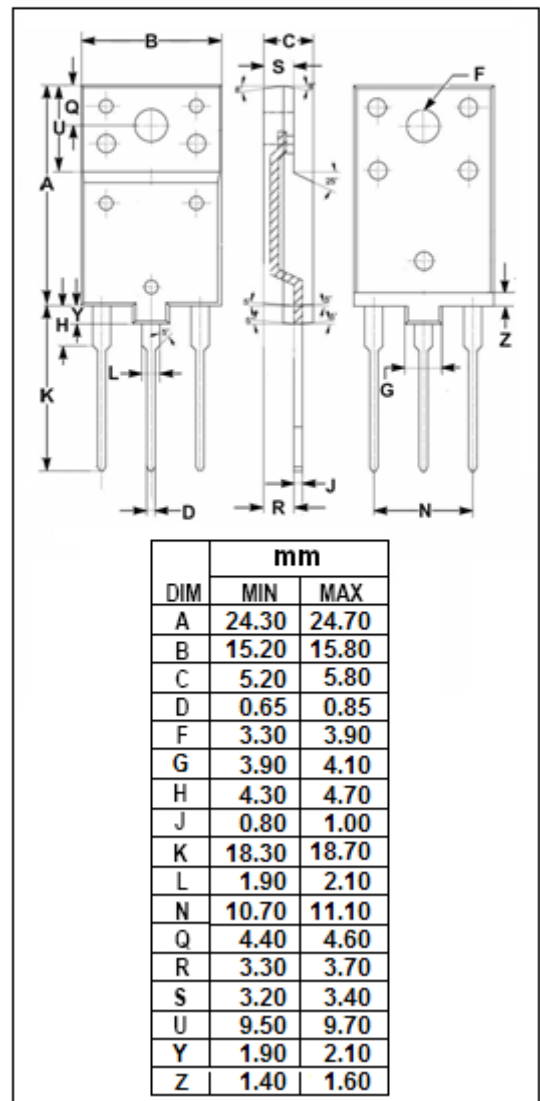
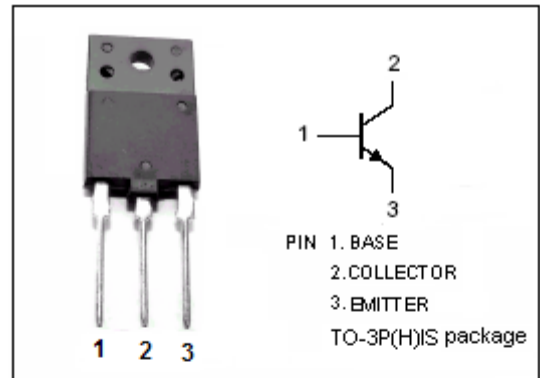

isc Silicon NPN Power Transistor**2SD1544****ELECTRICAL CHARACTERISTICS** $T_C=25^{\circ}\text{C}$ unless otherwise specified

SYMBOL	PARAMETER	CONDITIONS	MIN	TYP.	MAX	UNIT
$V_{CE(sat)}$	Collector-Emitter Saturation Voltage	$I_C=3\text{A}; I_B=0.8\text{A}$			8.0	V
$V_{BE(sat)}$	Base-Emitter Saturation Voltage	$I_C=3\text{A}; I_B=0.8\text{A}$			1.5	V
I_{CBO}	Collector Cutoff Current	$V_{CB}=500\text{V}; I_E=0$			10	μA
I_{EBO}	Emitter Cutoff Current	$V_{EB}=5\text{V}; I_C=0$			1.0	mA
h_{FE}	DC Current Gain	$I_C=0.5\text{A}; V_{CE}=5\text{V}$	8			
f_T	Current-Gain—Bandwidth Product	$I_C=0.1\text{A}; V_{CE}=10\text{V}$		3		MHz
C_{OB}	Output Capacitance	$I_E=0; V_{CB}=10\text{V}; f_{test}=1.0\text{MHz}$		95		pF
t_f	Fall Time	$I_{CP}=3\text{A}, I_{B1(end)}=0.8\text{A}$		0.5	1.0	μs