



5N70Z

Power MOSFET

5A, 700V LOGIC N-CHANNEL MOSFET

DESCRIPTION

The UTC **5N70Z** is an N-Channel enhancement MOSFET, it uses UTC's advanced technology to provide customers with a minimum on-state resistance, high switching speed and low gate charge. It can also withstand high energy pulse in the avalanche and commutation modes.

The UTC **5N70Z** is suitable for high efficiency switching DC/DC converter, motor control and switch mode power supply.

FEATURES

- * $R_{DS(ON)} < 2.5\Omega @ V_{GS}=10V$
- * Low gate charge (Typ=4.8nC)
- * Low C_{RSS} (Typ=6.0pF)
- * High switching speed
- * ESD Capability

SYMBOL

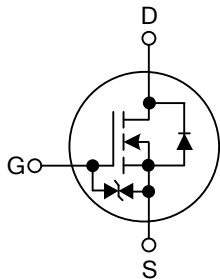

ORDERING INFORMATION

Ordering Number		Package	Pin Assignment			Packing
Lead Free	Halogen Free		1	2	3	
5N70ZL-TF3-T	5N70ZG-TF3-T	TO-220F	G	D	S	Tube
5N70ZL-TF1-T	5N70ZG-TF1-T	TO-220F1	G	D	S	Tube
5N70ZL-TF2-T	5N70ZG-TF2-T	TO-220F2	G	D	S	Tube
5N70ZL-TM3-T	5N70ZG-TM3-T	TO-251	G	D	S	Tube
5N70ZL-TN3-R	5N70ZG-TN3-R	TO-252	G	D	S	Tape Reel

Note: Pin Assignment: G: Gate D: Drain S: Source

<p>5N70ZL-TF3-T</p> <p>(1)Packing Type</p> <p>(2)Package Type</p> <p>(3)Lead Free</p>	<p>(1) T: Tube, R: Tape Reel</p> <p>(2) TF3: TO-220F, TF1: TO-220F1, TF2: TO-220F2</p> <p>TM3: TO-251, TN3: TO-252</p> <p>(3) L: Lead Free, G: Halogen Free</p>
---	---

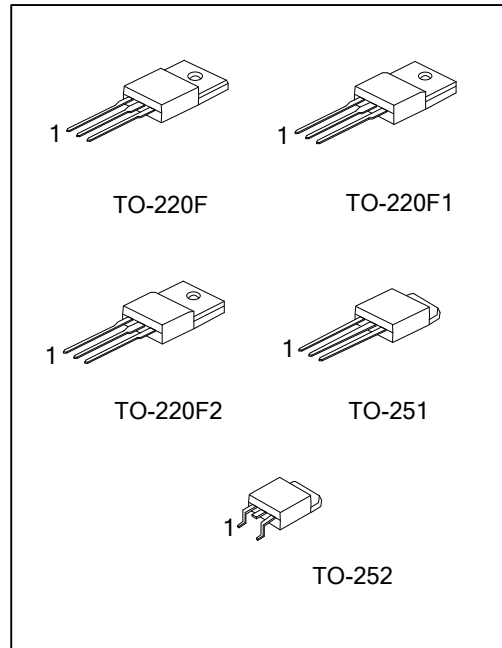

■ MARKING INFORMATION

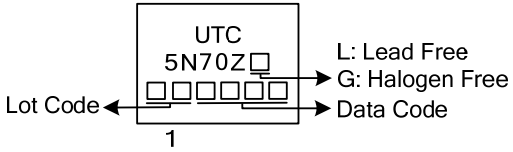
PACKAGE	MARKING
TO-220F TO-220F1 TO-220F2 TO-251 TO-252	 <p> L: Lead Free G: Halogen Free Data Code </p> <p>1</p>

■ ABSOLUTE MAXIMUM RATINGS ($T_c=25^\circ\text{C}$, unless otherwise noted)

PARAMETER		SYMBOL	RATINGS	UNIT
Drain-Source Voltage		V_{DSS}	700	V
Gate-Source Voltage		V_{GSS}	± 20	V
Avalanche Current (Note 2)		I_{AR}	5	A
Drain Current	Continuous	I_D	5	A
	Pulsed (Note 2)	I_{DM}	20	A
Avalanche Energy	Single Pulsed (Note 3)	E_{AS}	100	mJ
	Repetitive (Note 2)	E_{AR}	10	mJ
Peak Diode Recovery dv/dt (Note 4)		dv/dt	4.5	V/ns
Power Dissipation	TO-220F/TO-220F1	P_D	36	W
	TO-220F2			
	TO-251/TO-252		28	W
Junction Temperature		T_J	+150	$^\circ\text{C}$
Operation Temperature		T_{OPR}	-55~+150	$^\circ\text{C}$
Storage Temperature		T_{STG}	-55~+150	$^\circ\text{C}$

Notes: 1. Absolute maximum ratings are those values beyond which the device could be permanently damaged.

Absolute maximum ratings are stress ratings only and functional device operation is not implied.

2. Repetitive Rating: Pulse width limited by maximum junction temperature.

3. $L=6.2\text{mH}$, $I_{AS}=5\text{A}$, $V_{DD}=50\text{V}$, $R_G=25\Omega$, Starting $T_J=25^\circ\text{C}$.

4. $I_{SD}\leq 4.5\text{A}$, $di/dt\leq 300\text{A}/\mu\text{s}$, $V_{DD}\leq BV_{DSS}$, Starting $T_J=25^\circ\text{C}$

■ THERMAL CHARACTERISTICS

PARAMETER		SYMBOL	RATINGS	UNIT
Junction to Ambient	TO-220F/TO-220F1	θ_{JA}	62.5	$^\circ\text{C}/\text{W}$
	TO-220F2			
	TO-251/TO-252		110	$^\circ\text{C}/\text{W}$
Junction to Case	TO-220F/TO-220F1	θ_{JC}	3.47	$^\circ\text{C}/\text{W}$
	TO-220F2			
	TO-251/TO-252		4.53	$^\circ\text{C}/\text{W}$

■ ELECTRICAL CHARACTERISTICS ($T_C=25^\circ\text{C}$, unless otherwise noted)

PARAMETER		SYMBOL	TEST CONDITIONS	MIN	TYP	MAX	UNIT
OFF CHARACTERISTICS							
Drain-Source Breakdown Voltage		BV_{DSS}	$I_D=250\mu\text{A}$, $V_{GS}=0\text{V}$	700			V
Breakdown Voltage Temperature Coefficient		$\Delta BV_{DSS}/\Delta T_J$	Reference to 25°C , $I_D=250\mu\text{A}$		0.18		$^\circ\text{V}/^\circ\text{C}$
Drain-Source Leakage Current		I_{DSS}	$V_{DS}=700\text{V}$, $V_{GS}=0\text{V}$			1	μA
			$V_{DS}=560\text{V}$, $V_{GS}=0\text{V}$, $T_C=125^\circ\text{C}$			10	μA
Gate-Source Leakage Current	Forward	I_{GSS}	$V_{GS}=+20\text{V}$, $V_{DS}=0\text{V}$			+10	μA
	Reverse		$V_{GS}=-20\text{V}$, $V_{DS}=0\text{V}$			-10	μA
ON CHARACTERISTICS							
Gate Threshold Voltage		$V_{GS(TH)}$	$V_{DS}=V_{GS}$, $I_D=250\mu\text{A}$	2		4	V
Static Drain-Source On-State Resistance		$R_{DS(ON)}$	$V_{GS}=10\text{V}$, $I_D=2.5\text{A}$		2.15	2.5	Ω
DYNAMIC PARAMETERS							
Input Capacitance		C_{ISS}	$V_{GS}=0\text{V}$, $V_{DS}=25\text{V}$, $f=1.0\text{MHz}$		420	625	pF
Output Capacitance		C_{OSS}			55	65	pF
Reverse Transfer Capacitance		C_{RSS}			9	12	pF
SWITCHING PARAMETERS							
Turn-ON Delay Time		$t_{D(ON)}$	$V_{DD}=30\text{V}$, $I_D=0.5\text{A}$, $R_G=25\Omega$ (Note 1, 2)		40	60	ns
Rise Time		t_R			42	60	ns
Turn-OFF Delay Time		$t_{D(OFF)}$			135	155	ns
Fall-Time		t_F			48	60	ns
Total Gate Charge		Q_G	$V_{GS}=5\text{V}$, $V_{DS}=160\text{V}$, $I_D=4.5\text{A}$ (Note 1, 2)		70	90	nC
Gate to Source Charge		Q_{GS}			20		nC
Gate to Drain Charge		Q_{GD}			15		nC
SOURCE- DRAIN DIODE RATINGS AND CHARACTERISTICS							
Maximum Body-Diode Continuous Current		I_S				5	A
Maximum Body-Diode Pulsed Current		I_{SM}				20	A
Drain-Source Diode Forward Voltage		V_{SD}	$I_S=5\text{A}$, $V_{GS}=0\text{V}$			1.4	V
Body Diode Reverse Recovery Time		t_{rr}	$I_S=4.5\text{A}$, $V_{GS}=0\text{V}$, $di_F/dt=100\text{A}/\mu\text{s}$		95		ns
Body Diode Reverse Recovery Charge		Q_{RR}	(Note 1)		0.3		μC

Notes: 1. Pulse Test: Pulse width $\leq 300\mu\text{s}$, Duty cycle $\leq 2\%$

2. Essentially independent of operating temperature

■ TEST CIRCUITS AND WAVEFORMS

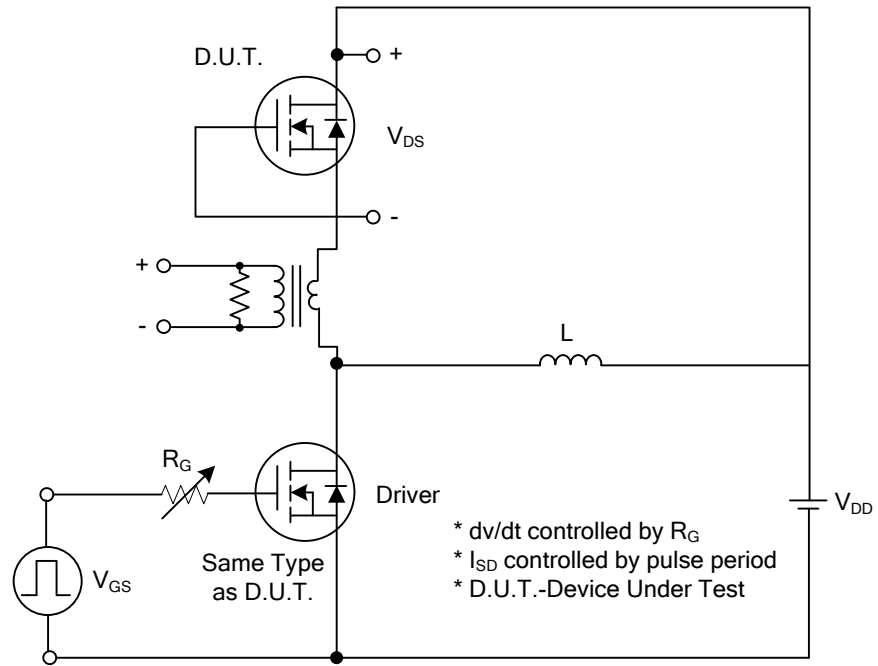

Peak Diode Recovery dv/dt Test Circuit

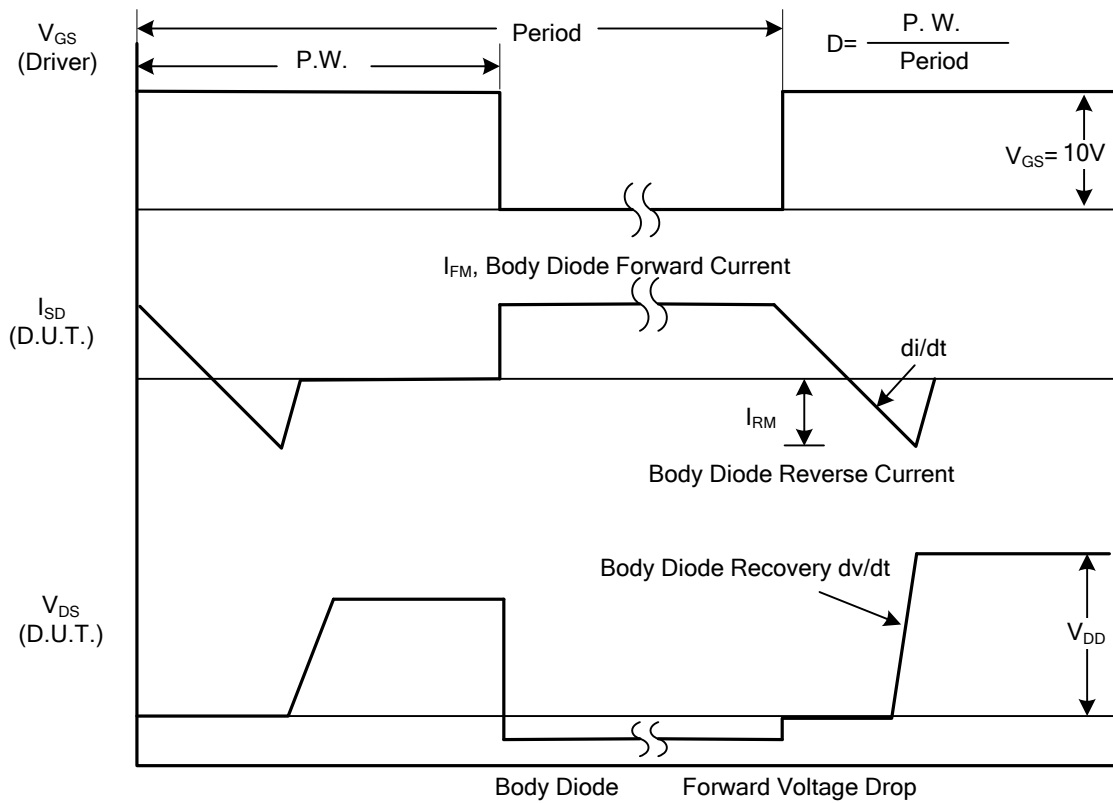

TEST CIRCUITS AND WAVEFORMS(Cont.)

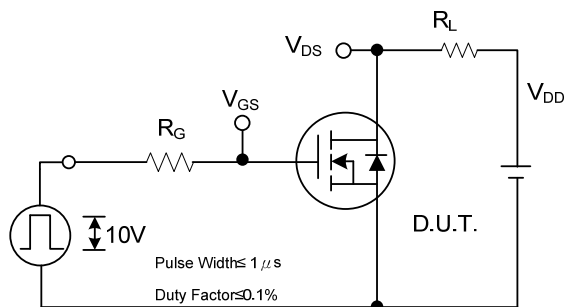

Switching Test Circuit

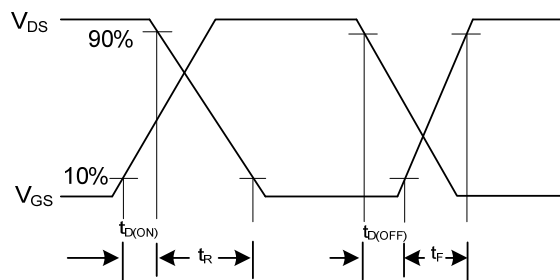

Switching Waveforms

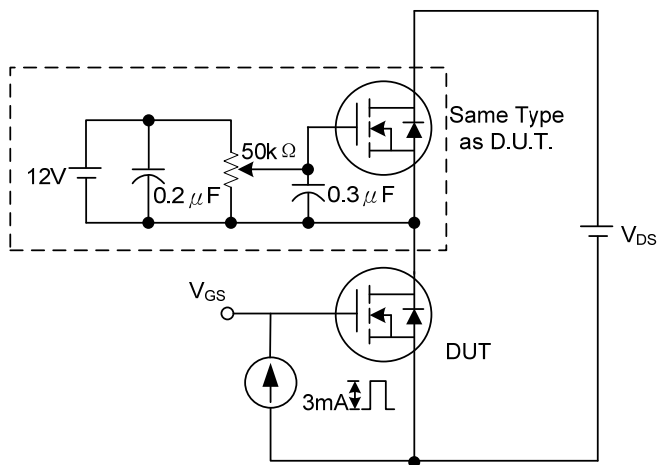

Gate Charge Test Circuit

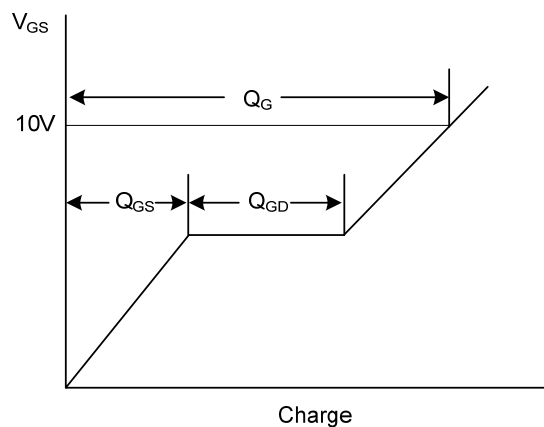

Gate Charge Waveform

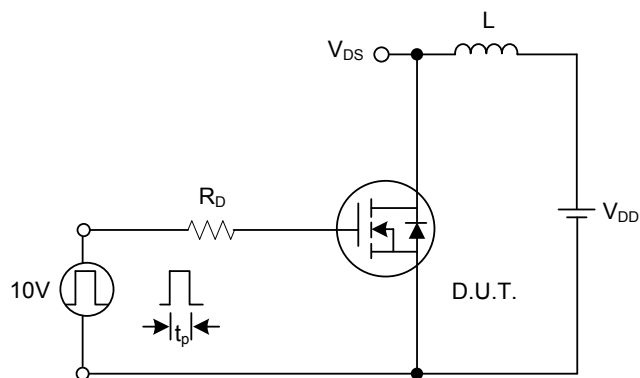

Unclamped Inductive Switching Test Circuit

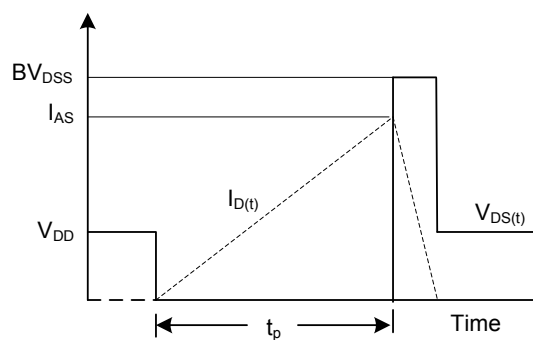

Unclamped Inductive Switching Waveforms

TYPICAL CHARACTERISTICS

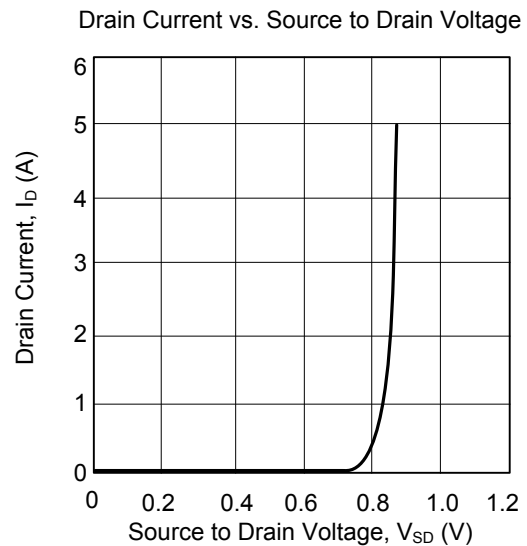
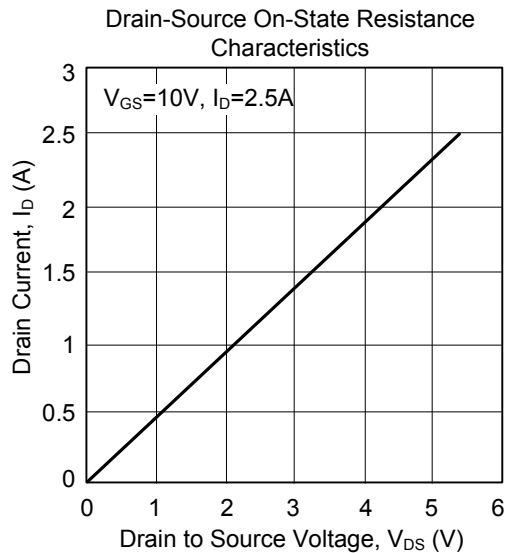
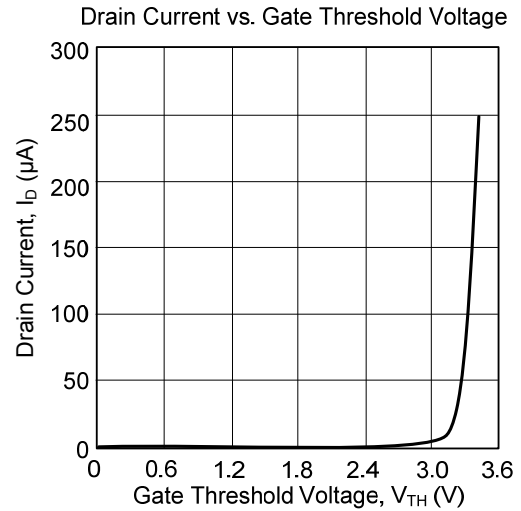
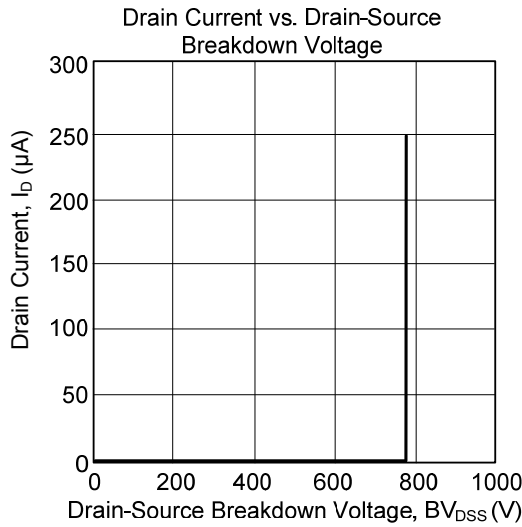

UTC assumes no responsibility for equipment failures that result from using products at values that exceed, even momentarily, rated values (such as maximum ratings, operating condition ranges, or other parameters) listed in products specifications of any and all UTC products described or contained herein. UTC products are not designed for use in life support appliances, devices or systems where malfunction of these products can be reasonably expected to result in personal injury. Reproduction in whole or in part is prohibited without the prior written consent of the copyright owner. The information presented in this document does not form part of any quotation or contract, is believed to be accurate and reliable and may be changed without notice.