

High Power Leaded Chip Attenuators

Style LA1

General Specifications

- **Frequency Range:** DC to 3 GHz
- **Input Power*:** 150 Watts
- **Operating Temp Range:** -55 to +150°C
- **Attenuation Stability**:** 0.0001 dB/dB/°C, Max.
- **Resistive Elements:** Tantalum Nitride
- **Substrate Material:** Aluminum Nitride
- **Tabs:** 99.99% Pure Silver, .004 inches thick, Cover: Alumina
- **RoHS Compliant**
- **Reliability:** MIL-PRF-55342

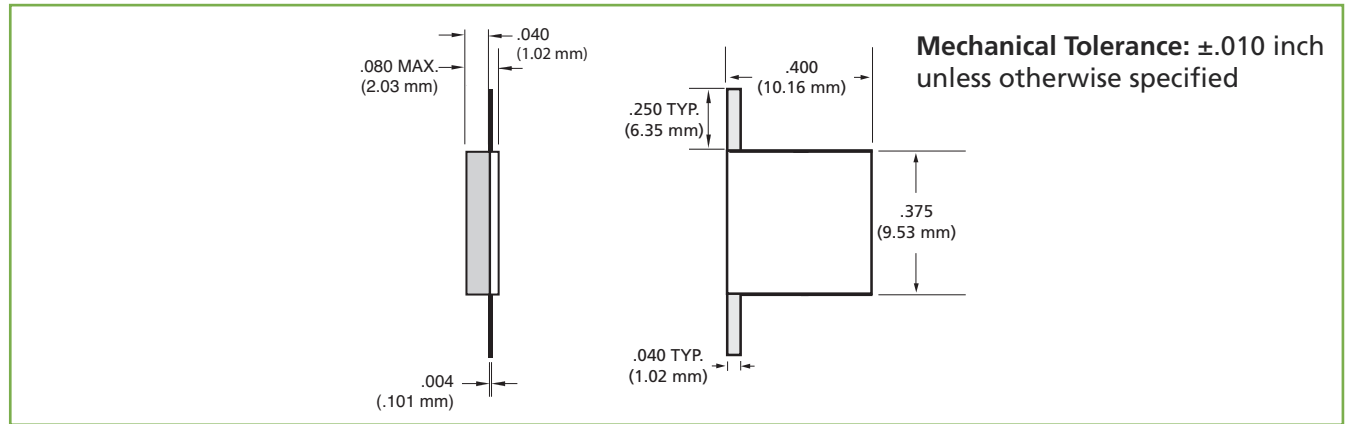

ATC Part Number	Nominal Attenuation (dB)	Frequency Sensitivity (dB, max.)	Maximum Deviation from Nominal (dB)	VSWR (max.)
LA13740P01DBFBK	1	± 0.20	+0.45 / -0.15	1.55
LA13740P02DBFBK	2	± 0.30	0.50 / -0.30	1.50
LA13740P03DBFBK	3	± 0.30	0.60 / -0.30	1.50
LA13740P06DBFBK	6	± 0.30	+0.60 / -0.20	1.30
LA13740P09DBFBK	9	± 0.30	+0.60 / -0.20	1.30
LA13740P10DBFBK	10	± 0.20	+0.40 / -0.30	1.25
LA13740P17DBFBK	17	± 1.00	+1.00 / -1.20	1.30
LA13740P20DBFBK	20	± 1.00	+1.00 / -1.20	1.25
LA13740P30DBFBK	30	± 1.05	+1.75 / -1.20	1.25

For Attenuator Power Handling vs. Mounting Surface Temperature, see following page.

ATC Leaded Chip Attenuators Part Number Code

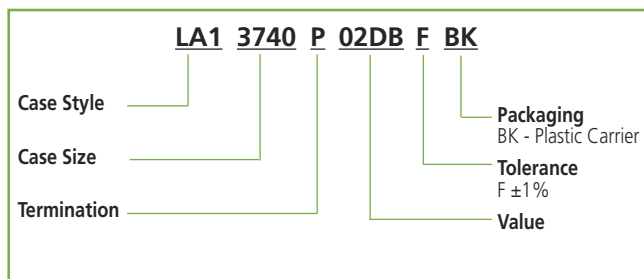

Attenuator Power Handling vs. Mounting Surface Temperature

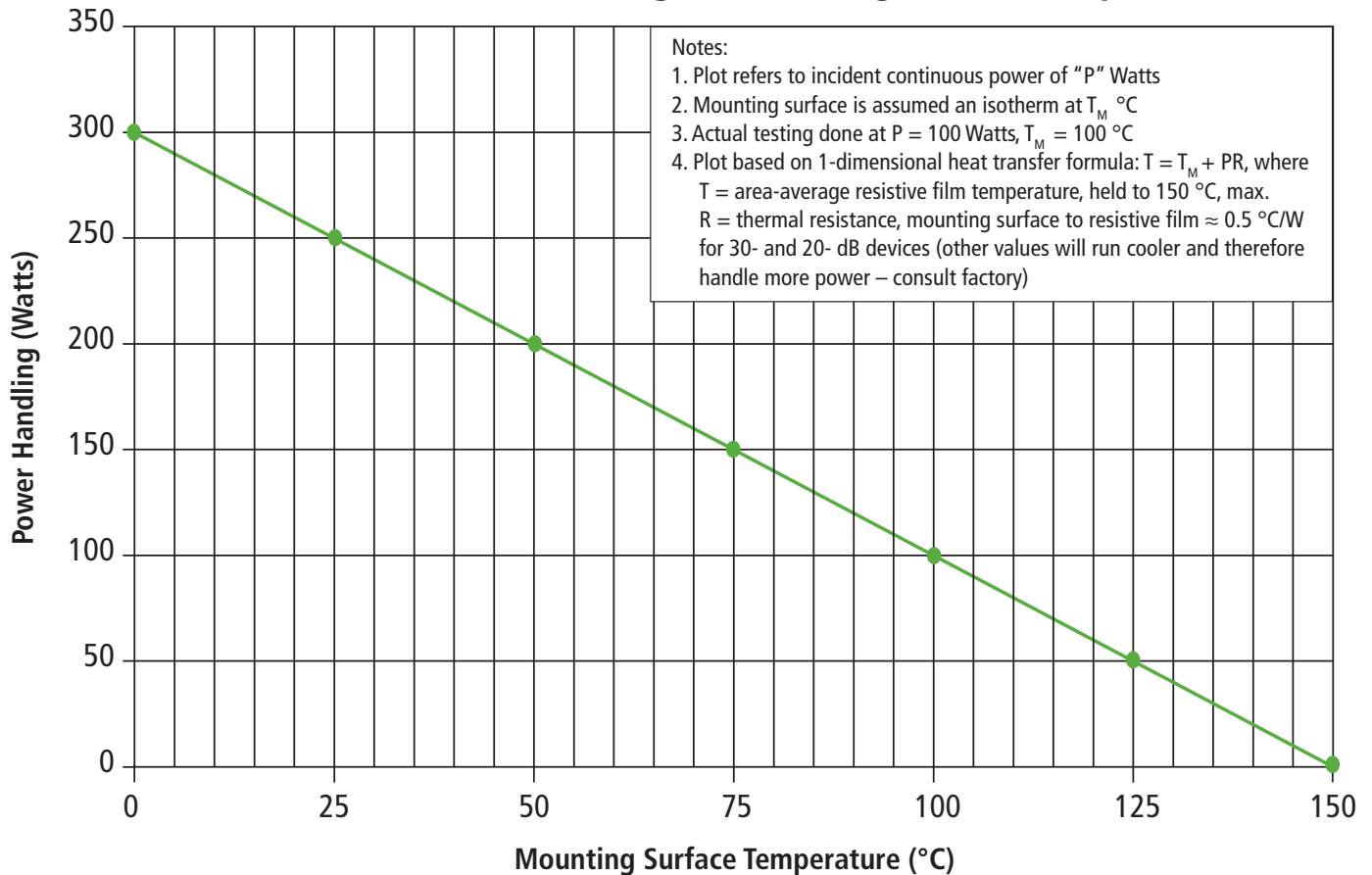

* Test Condition: With mounting surface temperature = 75 °C, max. (see plot above). Actual test conditions are as follows: Flange attached to a large copper carrier whose surface, directly under the flange center, is held at 100 °C; power applied = 100 Watts. Specification: The attenuation shall change no more that 0.2 dB during and after a 100-hr. Burn-in per MIL-PRF-55342.

** Attenuation vs. frequency as a function of temperature, -55°C to +125°C

Sales of ATC products are subject to the terms and conditions contained in American Technical Ceramics Corp. Terms and Conditions of Sale (ATC document #001-992 Rev. B 12/05). Copies of these terms and conditions will be provided upon request. They may also be viewed on ATC's website at www.atceramics.com/productfinder/default.asp. Click on the link for Terms and Conditions of Sale.

ATC has made every effort to have this information as accurate as possible. However, no responsibility is assumed by ATC for its use, nor for any infringements of rights of third parties which may result from its use. ATC reserves the right to revise the content or modify its product without prior notice.

© 2012 American Technical Ceramics Corp. All Rights Reserved.

Excerpt from ATC # 001-944; Rev. R, 11/13

A M E R I C A N T E C H N I C A L C E R A M I C S

ATC North America
sales@atceramics.com

ATC Europe
saleseur@atceramics.com

ATC Asia
sales@atceramics-asia.com

www.atceramics.com