

FEATURES

- ▶ SMD Package with Industry Standard Pinout
- ▶ Package Dimension:
 - 12.7 x 9.3 x 8.9 mm (0.5" x 0.37" x 0.35") Single Output Models
 - 15.3 x 9.3 x 8.9 mm (0.6" x 0.37" x 0.35") Dual Output Models
- ▶ I/O-Isolation 1000 VDC
- ▶ Operating Temp. Range -40° to +85°C
- ▶ High Accuracy of Pin Planarity
- ▶ Qualified for lead-free reflow solder process according IPC/JEDEC J-STD-020D
- ▶ Tape & Reel Package available
- ▶ 3 Year Product Warranty



PRODUCT OVERVIEW

The MINMAX MSAU400 series is a range of 2W DC/DC converters in a SMD- Package featuring I/O-isolation of 1000VDC. The small footprint makes this product the ideal solution for many applications where a voltage has to be isolated i.e for noise reduction, ground loop elimination, in digital interfaces or where a converted voltage is required.

A high efficiency allows an operating temperature range of -40°C to +85°C (with derating). These converters are fully qualified for the higher temperature profile used in lead-free reflow solder processes. For automated SMD production lines the product can also be supplied in tape & reel package.

Model Selection Guide

Model Number	Input Voltage (Range) VDC	Output Voltage VDC	Output Current		Input Current		Load Regulation % (max.)	Max. capacitive Load uF	Efficiency (typ.)
			Max.	Min.	@Max. Load	@No Load			@Max. Load
			mA	mA	mA(typ.)	mA(typ.)			%
MSAU401	5 (4.5 ~ 5.5)	5	400	8	519	60	11	47	77
MSAU403		12	165	3	488		11	10	81
MSAU406		±5	±200	±4	519		12	10#	77
MSAU408		±12	±83	±1.5	504		7	4.7#	79
MSAU409		±15	±66	±1	501		7	4.7#	79
MSAU411	12 (10.8 ~ 13.2)	5	400	8	213	30	8	47	78
MSAU413		12	165	3	201		6	10	82
MSAU418		±12	±83	±1.5	202		5	4.7#	82
MSAU419		±15	±66	±1	201		5	4.7#	82
MSAU421		5	400	8	106		8	47	78
MSAU423	24 (21.6 ~ 26.4)	12	165	3	101	15	5	10	81
MSAU428		±12	±83	±1.5	102		5	4.7#	81
MSAU429		±15	±66	±1	100		5	4.7#	82

For each output

Input Specifications

Parameter	Model	Min.	Typ.	Max.	Unit
Input Voltage Range	5V Input Models	4.5	5	5.5	VDC
	12V Input Models	10.8	12	13.2	
	24V Input Models	21.6	24	26.4	
Input Surge Voltage (1 sec. max.)	5V Input Models	-0.7	---	9	VDC
	12V Input Models	-0.7	---	18	
	24V Input Models	-0.7	---	30	
Reverse Polarity Input Current	All Models	---	---	0.3	A
Input Filter		Internal Capacitor			
Internal Power Dissipation		---	---	650	mW

Output Specifications

Parameter	Conditions	Min.	Typ.	Max.	Unit
Output Voltage Accuracy		---	±1.5	±4.0	%
Output Voltage Balance	Dual Output, Balanced Loads	---	±0.1	±1.0	%
Line Regulation	For Vin Change of 1%	---	±1.2	±1.5	%
Load Regulation	Io=20% to 100%	See Model Selection Guide			
Ripple & Noise (20MHz)		---	100	120	mV _{P-P}
Ripple & Noise (20MHz)	Over Line, Load & Temp.	---	---	200	mV _{P-P}
Ripple & Noise (20MHz)		---	---	15	mV _{rms}
Temperature Coefficient		---	±0.01	±0.02	%/°C
Short Circuit Protection		0.5 Second Max.			

General Specifications

Parameter	Conditions	Min.	Typ.	Max.	Unit
I/O Isolation Voltage (rated)	60 Seconds	1000	---	---	VDC
I/O Isolation Resistance	500 VDC	1000	---	---	MΩ
I/O Isolation Capacitance	100KHz, 1V	---	60	100	pF
Switching Frequency		50	100	120	KHz
MTBF (calculated)	MIL-HDBK-217F@25°C, Ground Benign	2,000,000	---	---	Hours
Moisture Sensitivity Level (MSL)	IPC/JEDEC J-STD-020D	Level 3			

Input Fuse

5V Input Models	12V Input Models	24V Input Models
100mA Slow-Blow Type	500mA Slow-Blow Type	200mA Slow-Blow Type

Environmental Specifications

Parameter	Conditions	Min.	Max.	Unit
Operating Temperature Range (with Derating)	Ambient	-40	+85	°C
Case Temperature		---	+90	°C
Storage Temperature Range		-50	+125	°C
Humidity (non condensing)		---	95	% rel. H
Cooling	Free-Air convection			
Lead Temperature (1.5mm from case for 10Sec.)		---	300	°C

Power Derating Curve

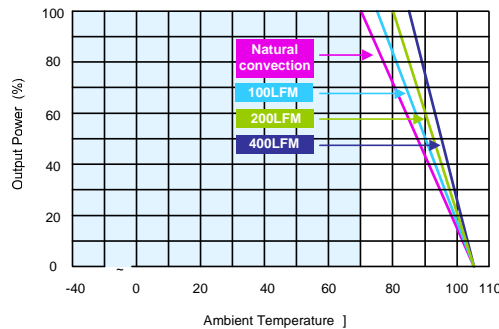

Notes

- Specifications typical at Ta=+25°C, resistive load, nominal input voltage and rated output current unless otherwise noted.
- Ripple & Noise measurement bandwidth is 0-20MHz.
- These power converters require a minimum output loading to maintain specified regulation, operation under no-load conditions will not damage these modules; however they may not meet all specifications listed.
- All DC/DC converters should be externally fused at the front end for protection.
- Other input and output voltage may be available, please contact factory.
- Specifications subject to change without notice.

Package Specifications

Mechanical Dimensions (Single Output)

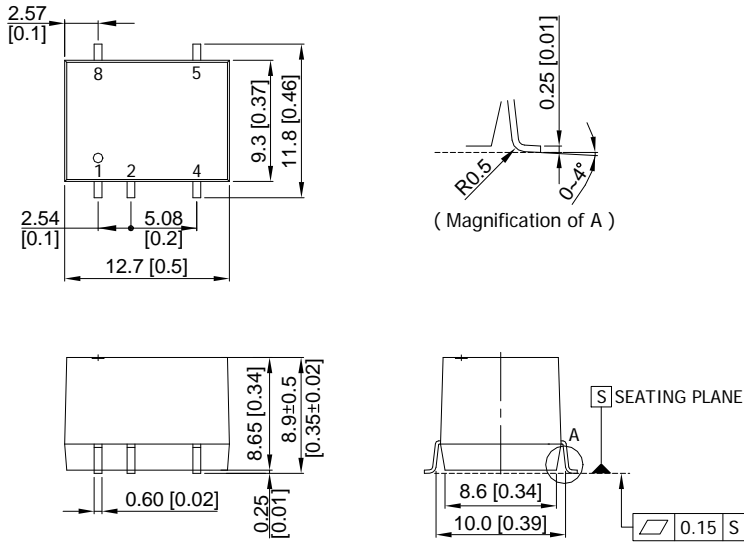

Connecting Pin Patterns

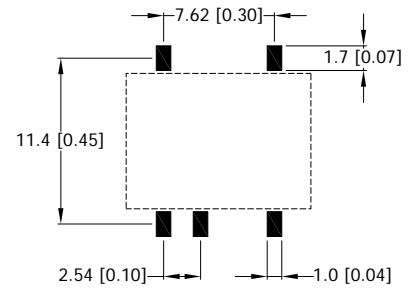

Package Specifications

Mechanical Dimensions (Dual Output)

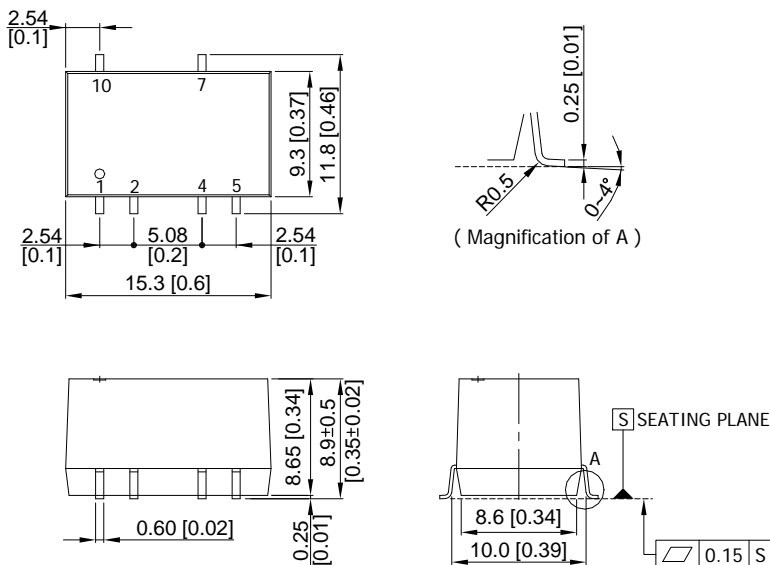

Connecting Pin Patterns

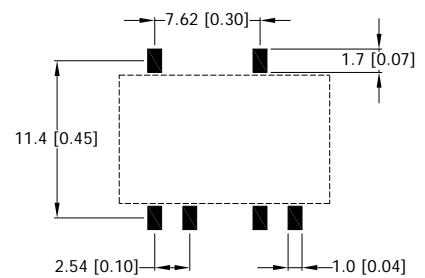

- ▶ All dimensions in mm (inches)
- ▶ Tolerance: X.X±0.25 (X.XX±0.01)
X.XX±0.13 (X.XXX±0.005)
- ▶ Pins ±0.05(±0.002)

Pin Connections	Single Output	Dual Output
Pin		
1	-Vin	-Vin
2	+Vin	+Vin
4	-Vout	Common
5	+Vout	-Vout
7	No Pin	+Vout
8	NA	No Pin
10	No Pin	NA

NA : Not Available for Electrical Connection

Physical Characteristics	
Case Size (Single Output)	: 12.7x9.3x8.65mm (0.50x0.37x0.34 Inches)
Case Size (Dual Output)	: 15.3x9.3x8.65mm (0.60x0.37x0.34 Inches)
Case Material	: Molding (flammability to UL 94V-0 rated)
Weight (Single Output)	: 1.5g
Weight (Dual Output)	: 2.2g

Test Configurations

Input Reflected-Ripple Current Test Setup

Input reflected-ripple current is measured with an inductor L_{in} (4.7uH) and C_{in} (220uF, ESR < 1.0Ω at 100 KHz) to simulate source impedance. Capacitor C_{in} , offsets possible battery impedance. Current ripple is measured at the input terminals of the module, measurement bandwidth is 0-500 KHz.

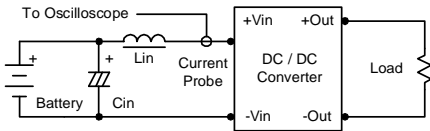

Peak-to-Peak Output Noise Measurement Test

Use a C_{out} 0.33uF ceramic capacitor. Scope measurement should be made by using a BNC socket, measurement bandwidth is 0-20 MHz. Position the load between 50 mm and 75 mm from the DC/DC Converter.

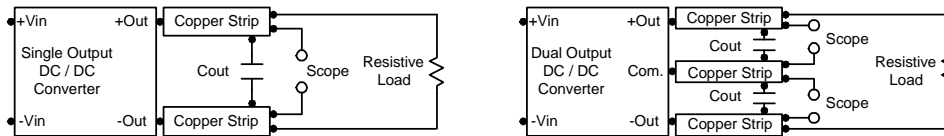

Design & Feature Considerations

Maximum Capacitive Load

The MSAU400 series has limitation of maximum connected capacitance at the output. The power module may be operated in current limiting mode during start-up, affecting the ramp-up and the startup time. The maximum capacitance can be found in the data sheet.

Input Source Impedance

The power module should be connected to a low ac-impedance input source. Highly inductive source impedances can affect the stability of the power module. In applications where power is supplied over long lines and output loading is high, it may be necessary to use a capacitor at the input to ensure startup. Capacitor mounted close to the power module helps ensure stability of the unit, it is recommended to use a good quality low Equivalent Series Resistance (ESR < 1.0Ω at 100 KHz) capacitor of a 2.2uF for the 5V input devices, a 1.0uF for the 12V input devices and a 0.47uF for the 24V devices.

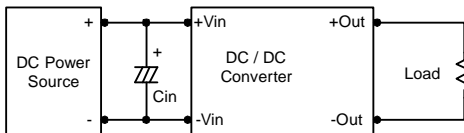

Output Ripple Reduction

A good quality low ESR capacitor placed as close as practicable across the load will give the best ripple and noise performance. To reduce output ripple, it is recommended to use 1.5uF capacitors at the output.

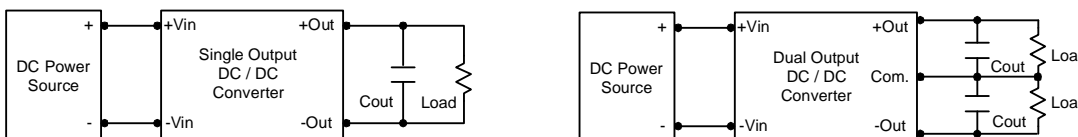

Thermal Considerations

Many conditions affect the thermal performance of the power module, such as orientation, airflow over the module and board spacing. To avoid exceeding the maximum temperature rating of the components inside the power module, the case temperature must be kept below 90°C. The derating curves are determined from measurements obtained in a test setup.

