

Datasheet

**LambdaDriver® – Optical Band Splitters Module  
(EM800-MP2, EM800-MP2-50, EM800/EM1600-RBBS)**



**Features**

- Hot swappable
- Functional in non-powered mode

**Applications**

- DWDM networks In-service upgrade
- In-service optical monitoring

**Overview**

The optical passive splitter and interleaver modules are important building blocks of the LambdaDriver Optical Transport System and serve at optical communication nodes to divide /split and transport the optical bandwidth as portions of optical sub-bands. The applications include:

- a. In service **Power monitoring** – A portion (usually 5%) of the incoming optical signal is taken to a “monitor” port for connecting to measurement equipment while the rest of the signal is transported transparently to the output port.
- b. Separating the Optical spectrum to different bands - **Band Splitter** devices transport a specific band of DWDM channels to an output port.

As an example the “Red”/“Blue” Band Splitter separates the Incoming optical signal between two Output ports, each forwarding only the channels that belong to the specific band (Red or Blue).

- c. Combining/Splitting DWDM 100Ghz spaced channels over 50Ghz spacing transport – **Interleaver**. In order to increase the number of DWDM wavelength forwarded over existing infrastructure, 100GHz spaced channels shifted by 50Ghz are combined by the interleaver thus doubling the number of channels transported over the same media.

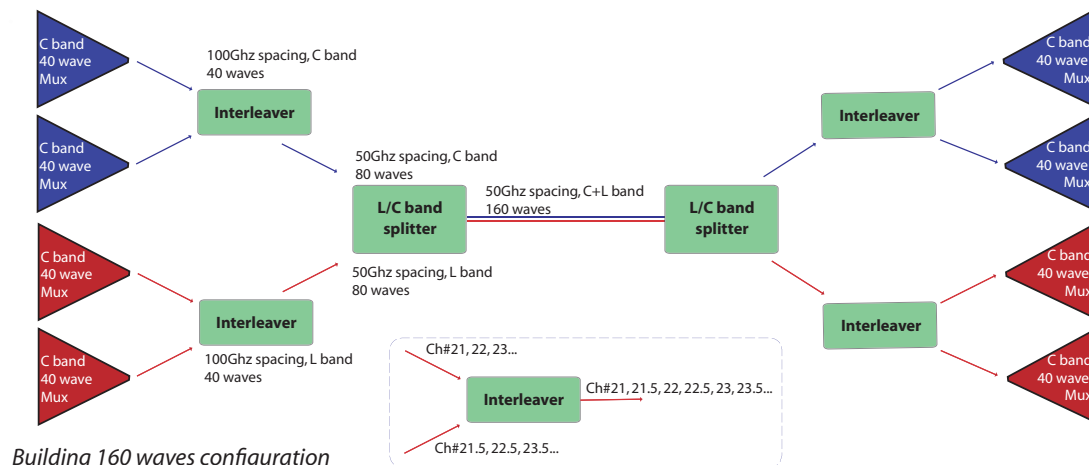

The functionality of the above mentioned modules permits performing seamless and uninterrupted network scalability and addition of new services.

Dual and quad Red/Blue and L-band/C-band Band Splitter modules are available as part of the Lambda Driver Optical Transport System.

The Optical Power Monitoring device is a special splitter that filters 5% of the incoming optical signal to a separate interface on the module while the remaining 95% continues its path without being additionally affected due to the high (min 40db) isolation between the monitoring port and the main path.

Measuring and analysis equipment can be attached to the monitoring port for troubleshooting or advanced alert purposes. 50% power splitters are also available.

### Environmental

<b>Operating Temperature</b>	-5 °C to +65 °C
<b>Storage Temperature</b>	-20 °C to +75 °C
<b>Relative Humidity</b>	85% max, non-condensing
<b>Dimensions (W x H x D)</b>	26.93 x 130.7 x 227mm ( 1.06 x 5.145 x 8.956 in)
<b>Weight</b>	EM800: 0.42 kg (0.9 lb)    EM1600: 0.84 kg (1.8 lb)
<b>Power consumption</b>	0.33 Watt

### Technical Specifications

RBBS	
<b>Red Band</b>	ch 21 to ch 36
<b>Blue Band</b>	ch 43 to ch 58
<b>Insertion loss RED - Pass</b>	1.2 db
<b>Insertion loss BLUE - Reflect</b>	0.8 db
<b>Isolation Common - Pass</b>	30db min.
<b>Isolation Common - Reflect</b>	13db min.
<b>Return loss</b>	50db min.
Interleaver	
<b>Insertion loss</b>	2.0db
<b>Return loss</b>	45db min.
Power Splitter	
<b>Insertion loss 50/50 %</b>	typical 3.2dB/3.2dB
<b>Directivity</b>	40db min.
<b>Insertion loss 5/95 %</b>	typical 13.5dB/0.8dB
<b>Directivity</b>	40db min.

All parameters include connectors

Order Info	Product	Description
	<b>EM1600-RBBS4</b>	Red - Blue quad Band Splitter for LD1600
	<b>EM1600-RBBS2</b>	Red - Blue dual Band Splitter for LD1600
	<b>EM1600-CLBS2</b>	C - L dual Band Splitter for LD1600
	<b>EM800-MP2-50</b>	Dual 50% Splitter ports module for LD800
	<b>EM800-MP2</b>	Dual 5% Monitoring ports module for LD400/800
	<b>EM800-MP2E2</b>	Dual 5% Monitoring ports module with E2000 connectors at line ports
	<b>EM800-RBBS4</b>	Red - Blue quad Band Splitter for LD800
	<b>EM800-RBBS2</b>	Red - Blue dual Band Splitter for LD800
	<b>EM800-CLBS2</b>	C - L dual Band Splitter for LD800
	<b>EM800-CIN502</b>	C - Band dual 50Ghz Interleaver for LD800

All statements, technical information and recommendations related to the products herein are based upon information believed to be reliable or accurate. However, the accuracy or completeness thereof is not guaranteed, and no responsibility is assumed for any inaccuracies. Please contact MRV Communications for more information. MRV Communications and the MRV Communications logo are trademarks of MRV Communications, Inc. Other trademarks are the property of their respective holders.