HA13558AFH

CD-ROM Combo Driver

HITACHI

ADE-207-235C (Z)

4th Edition

November 1, 1997

Description

The HA13558AFH is combination of Spindle, Focus, Tracking, Slider, Tray designed for CD-ROM and have following function and features.

Functions

- 1.5 A sensorless spindle driver
- 0.5 A BTL focus driver
- 0.5 A BTL tracking driver
- 1.5 A H bridge slider motor driver
- 1.0 A H bridge tray motor driver
- Amplitude detector circuit
- Over temperature shut down (OTSD)

Features

- Sensorless spindle driver
- Soft switching Drive
- Low output saturation voltage (spindle)

HA13558AFH

Pin Arrangement

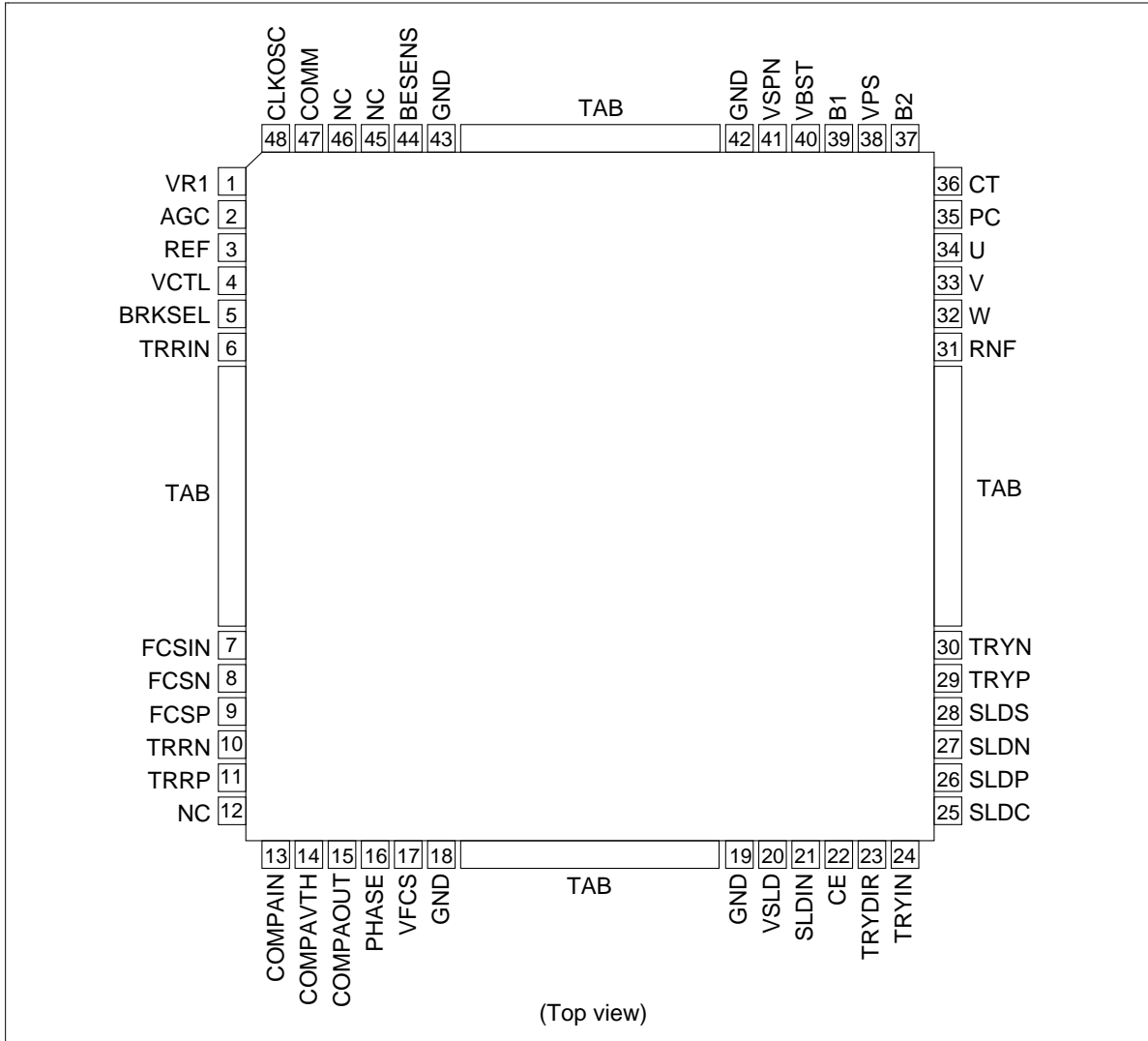

Pin Description

Pin No.	Pin Name	Function
1	VR1	Reference voltage. The IC's internal reference current is determined by this voltage and the external resistor Rref.
2	AGC	AGC for the soft switching function. Holds the level used for IC internal processing fixed even if the B-EMF level fluctuates due to the rotation speed.
3	REF	Reference voltage for the spindle control input, the FCS driver control input, the TRR driver control input, and the SLD driver control input.
4	VCTL	Spindle control input. Generates forward torque when a voltage higher than REF is applied, and brake when a voltage lower than REF is applied.
5	BRKSEL	To select the brake (L: Short brake, H: Reverse brake)
6	TRRIN	TRR driver control input. Takes the REF pin voltage as the reference.
7	FCSIN	FCS driver control input. Takes the REF pin voltage as the reference.
8, 9	FCSN & P	FCS driver output
10, 11	TRRN & P	TRR driver output
12	NC	No connection
13	COMPAIN	Amplitude detection comparator input. Connect either the FCS or TRR driver output to this pin.
14	COMPAVTH	Amplitude detection comparator threshold setting input. (Vin = 0.3 to 1.8 V)
15	COMPAOUT	Amplitude detection comparator output
16	PHASE	Outputs the B-EMF zero cross phase.
17	VFCS	Power supply for the FCS driver, TRR driver, and control block
20	VSLD	Power supply for the slide motor driver and tray motor driver
21	SLDIN	Slide control input. Takes the REF pin voltage as the reference.
22	CE	Chip enable
23	TRYDIR	Tray motor direction control
24	TRYIN	Tray motor drive PWM control input
25	SLDC	Slide off timer time constant. The PWM off time is determined by the external capacitor and resistor Cslid and Rref.
26, 27	SLDP & N	Slide motor driver output
28	SLDS	Slide driver current detection
29, 30	TRYP & N	Tray motor driver output
31	RNF	Spindle driver current detection
32, 33, 34	W, V, U	Spindle driver output
35	PC	Spindle driver output
36	CT	Spindle center tap
37, 39	BC2 & 1	Booster pumping capacitor connection

HA13558AFH

Pin Description (cont)

Pin No.	Pin Name	Function
38	VPS	DC-DC converter control block power supply
40	VBST	Booster output. This circuit generates a voltage about 1.5 V above that of the VPS pin.
41	VSPN	Spindle power supply
44	BESENS	Spindle B-EMF input sensitivity switching pin. 12V: GND short, 5V: open
45	NC	No connection
46	NC	No connection
47	COMM	Sensorless motor startup oscillation time constant. The startup oscillation frequency is determined by the external capacitor and resistor Ccom and Rref.
48	CLKOSC	Clock oscillator circuit. The clock oscillator frequency is determined by the external capacitor and resistor Cclk and Rref.

Block Diagram

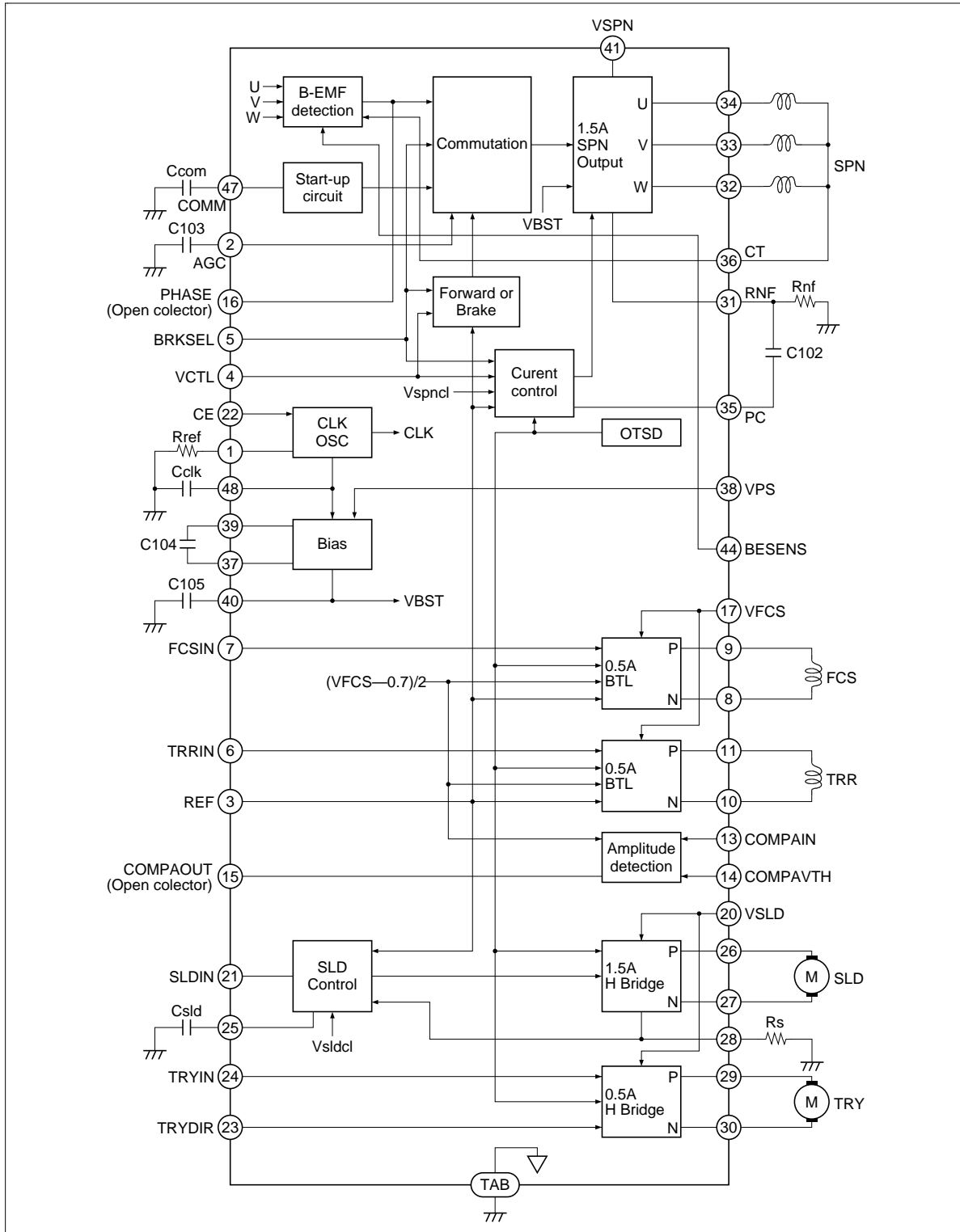

HA13558AFH

Truth Table

Table 1 Overall

CE	OTSD	SPN Driver	FCS Driver	TRR Driver	SLD Driver	TRY Driver
L	X	Z	Z	Z	Z	Z
H	ON	Z	Z	Z	Z	Z
	OFF	ON	ON	ON	ON	ON

Table 2 SPN Driver

BRKSEL	VCTL	SPN Driver
L	$> \text{REF} + \text{Vdzspn}$	Forward torque
	$\text{REF} \pm \text{Vdzspn}$	Z
	$< \text{REF} - \text{Vdzspn}$	Short brake
H	$> \text{REF} + \text{Vdzspn}$	Forward torque
	$\text{REF} \pm \text{Vdzspn}$	Z
	$< 0.8\text{V}$	Reverse brake (Full)

Table 3 FCS & TRR Drivers

FCS & TRRIN	P Output	N Output
$\leq \text{REF}$	SINK	SOURCE
$\geq \text{REF}$	SOURCE	SINK

Table 4 SLD Driver

SLDIN	P Output	N Output
$> \text{REF} + \text{Vdzsld}$	H	PWM
$\text{REF} \pm \text{Vdzsld}$	H	Z
$< \text{REF} - \text{Vdzsld}$	PWM	H

Table 5 TRY Driver

TRYDIR	TRYIN	P Output	N Output
L	L	Z	H
L	H	L	H
H	L	H	Z
H	H	H	L

Timing Chart

1. Start-up of Spindle

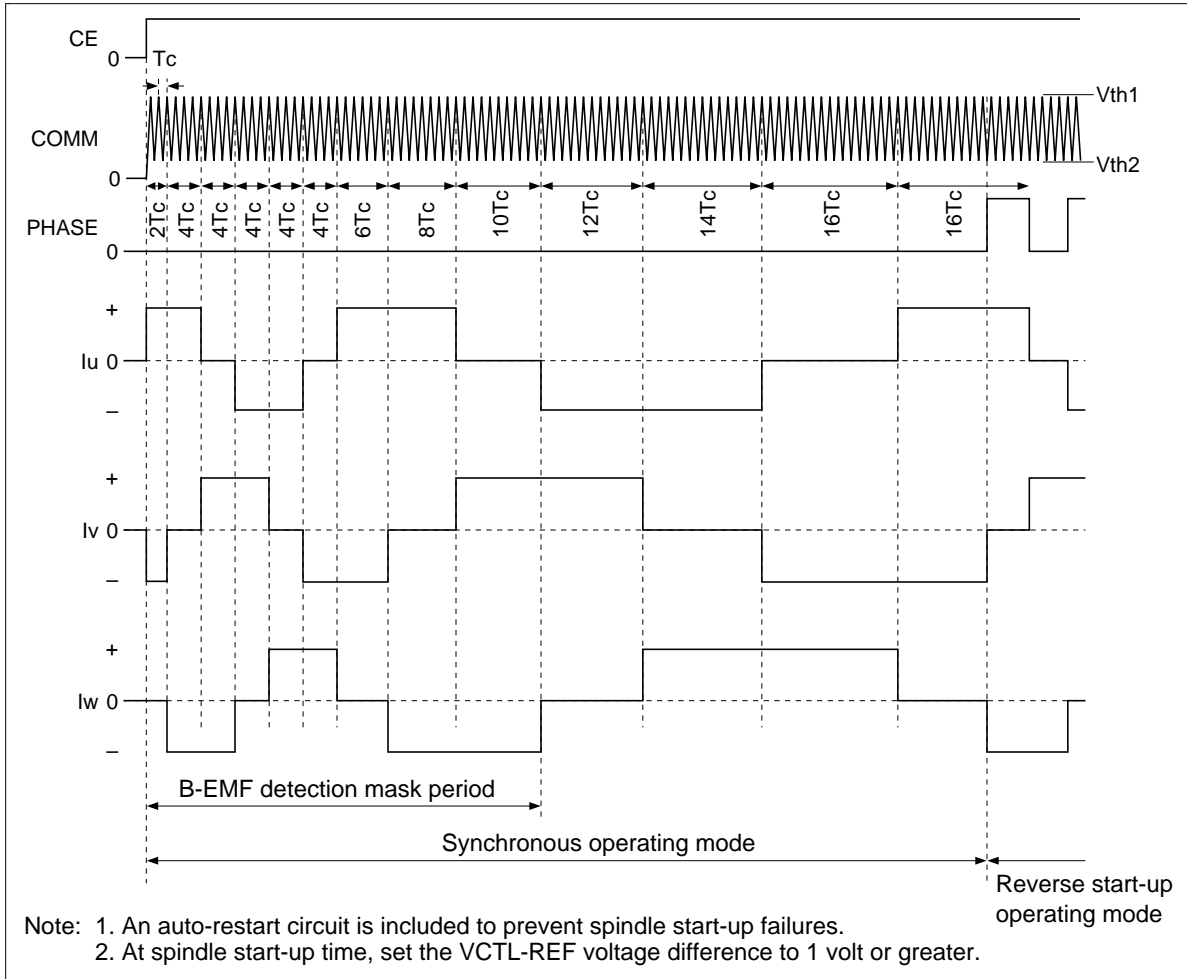

2. Commutation of Spindle

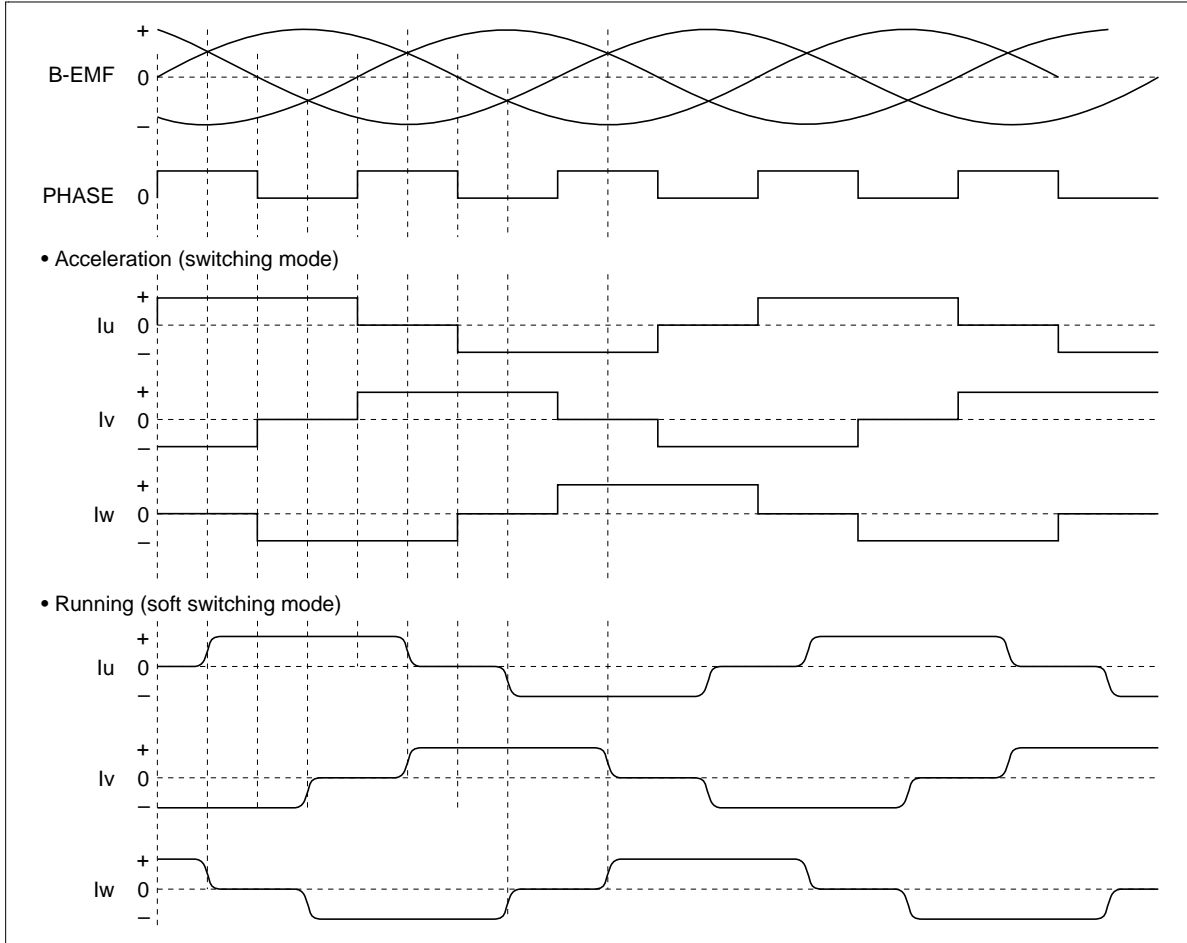

Application

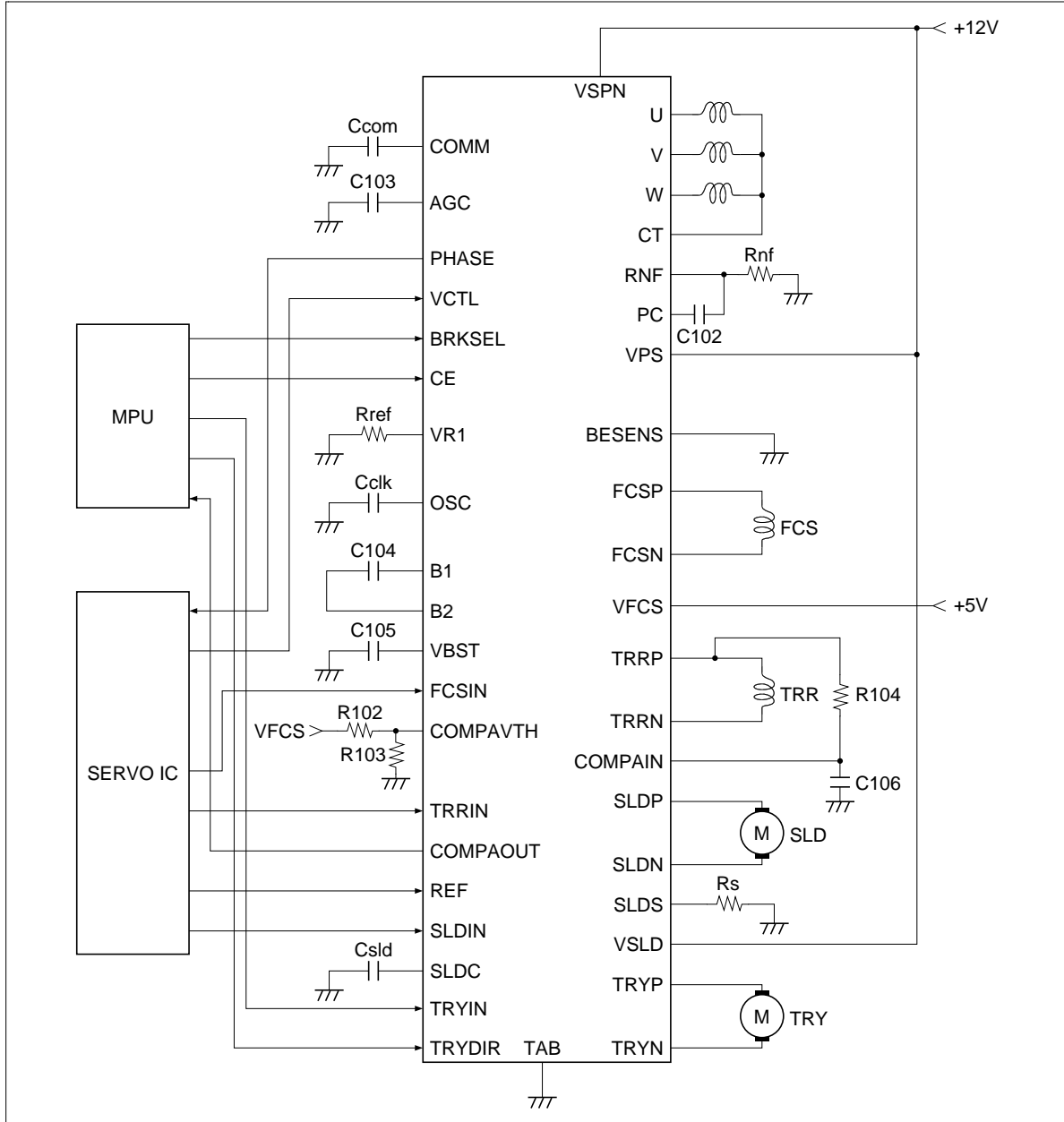

HA13558AFH

External Components

Parts No.	Recommended Value	Recommended range	Purpose	Note
R102, R103	—	—	for Amplitude detection voltage setting	
R104	—	—	for Amplitude detection filter	
Rnf	0.47Ω	≥ 0.27Ω	SPN driver current detection resistor	1
Rref	3.3kΩ	≥ 3.3kΩ	for Reference current setting	2 to 4
Rs	0.47Ω	≥ 0.27Ω	SLD driver current detection resistor	5
C102	0.1μF		for Phase compensation for SPN driver current control	
C103	0.1μF		for B-EMF amplitude AGC	
C104	0.1μF		for Booster pumping	
C105	0.47μF		for Booster output smoothing	
C106	—		for Amplitude detection filter	
Ccom	—		for Start-up oscillation	2
Cclk	47pF		for CLK oscillation	3
Csld	680pF		for Slide control offtime determining time constant	4

Notes: 1. The SPN driver maximum output current is determined by the following formula. Here, V_{spncl} is the current limiter reference voltage. (See the electrical characteristics table.)

$$I_{ospnmax} = \frac{V_{spncl}}{R_{nf}}$$

2. Determine this value using the following formula as a guideline.

$$T_{com} = \frac{1}{8} \sqrt{\frac{J}{P \cdot K_t \cdot I_{ospnmax}}} \sim \frac{1}{4} \sqrt{\frac{J}{P \cdot K_t \cdot I_{ospnmax}}}$$

$$C_{com} = \frac{T_{com} \cdot V_{r1}}{16 \cdot R_{ref} \cdot \Delta V_{thcom}}$$

where, J : Spindle inertia [kg · cm · s²]

P : Number of spindle motor poles [poles]

K_t : Spindle motor torque constant [kg · cm / A]

ΔV_{thcom} : Potential difference between the upper and lower V_{th} in the startup circuit
(ΔV_{thcom} ≈ 1.5V)

- Determine this value using the following formula as a guideline. Vr1 is the VR1 (pin 7) voltage (See the electrical characteristics table.) and ΔVthclk is the potential difference between the upper and lower Vth. (ΔVthclk is about 1.0 V)

$$C_{clk} = \frac{V_{r1}}{16 \cdot f_{clk} \cdot R_{ref} \cdot \Delta V_{thclk}}$$

Also, the maximum spindle rotation speed depend on the Cclk as following figure.

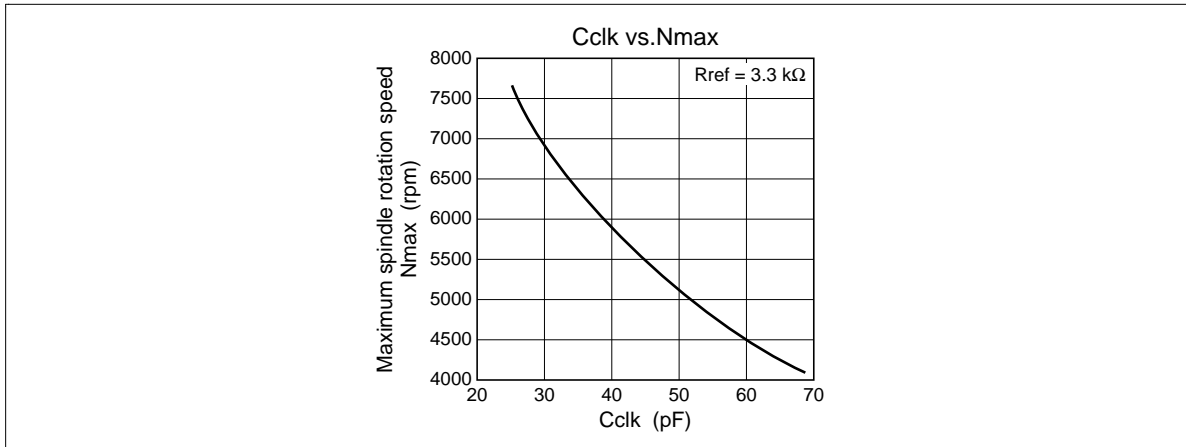

- Determine this value using the following formula as a guideline. Here, Vthslid is the SLD control circuit internal threshold voltage. (See the electrical characteristics table.)

$$C_{sld} = \frac{t_{offslid} \cdot V_{r1}}{8 \cdot R_{ref} \cdot V_{thslid}}$$

- The SLD driver maximum output current losldmax is determined by the following formula. Here, Vslidcl is the current limiter reference voltage. (See the electrical characteristics table.)

$$I_{osldmax} = \frac{V_{slidcl}}{R_s}$$

HA13558AFH

Absolute Maximum Ratings (Ta = 25°C)

Item	Symbol	Rating	Unit	Notes
Power supply voltage	Vps	15	V	1
SPN supply voltage	Vspn	15	V	
FCS & TRR supply voltage	Vfcs	7	V	
FCS & TRY supply voltage	Vsld	15	V	
Input voltage	Vin	0 to Vfcs	V	2
SPN output current	Iospn	1.5	A	3
FCS & TRR output current	Iofcs	0.5	A	
TRY output current	Iotry	1.0	A	
SLD output current	Iosld	1.5	A	
Power dissipation	P _T	5	W	4
Junction temperature	T _j	150	°C	1
Storage temperature	T _{stg}	-55 to +125	°C	

Notes: 1. Operating voltage range is shown below.

$$V_{ps} = 4.25 \text{ to } 13.8\text{V}$$

$$V_{spn} = 2.50 \text{ to } 15.0\text{V}$$

$$V_{fcs} = 4.25 \text{ to } 5.75\text{V}$$

$$V_{sld} = 4.25 \text{ to } 13.8\text{V}$$

$$T_{jopr} = 0 \text{ to } +135^{\circ}\text{C}$$

2. Applied to CE, VCTL, FCSIN, TRRIN, SLDIN, TRYIN, TRYDIR and BRKSEL.

3. ASO of each output transistor is shown below.

4. Thermal resistance is shown below.

$$\theta_{j-tab} \leq 12^{\circ}\text{C/W (preliminary)}$$

$$\theta_{j-a1} \leq 30^{\circ}\text{C/W (when mounted on 4 layer multi glass-epoxy board)}$$

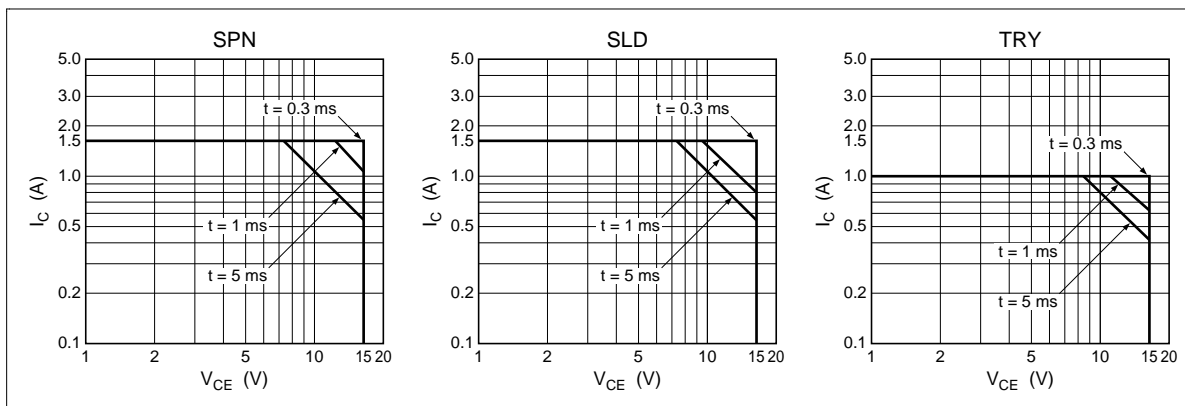

Electrical Characteristics ($T_a = 25^\circ\text{C}$, $V_{ps} = 12\text{V}$, $V_{spn} = 12\text{V}$, $V_{fcs} = 5\text{V}$, $V_{sld} = 12\text{V}$)

Item	Symbol	Min	Typ	Max	Unit	Test Conditions	Applicable Pins	Note	
Quiescent current	Ips0	0	0.01	0.10	mA	$V_{ps}=15.0\text{V}$, CE=L	38		
	Ifcs0	0.25	0.38	0.56	mA	$V_{fcs}=7.0\text{V}$, CE=L	17		
	Ispn0	0	0.135	0.17	mA	$V_{spn}=14\text{V}$, CE=L	41		
	Isld0	0	0.01	0.10	mA	$V_{sld}=15\text{V}$, CE=L	20		
	Ips	7.0	12.0	18.0	mA	$V_{ps}=15.0\text{V}$, CE=H	38		
	Ifcs	26.0	40.0	54.0	mA	$V_{fcs}=7.0\text{V}$, CE=H	17	1	
	Ispn	0	0.11	0.3	mA	$V_{spn}=14\text{V}$, CE=H	41		
	Isld	2.2	3.0	4.5	mA	$V_{sld}=15\text{V}$, CE=H	20		
Logic input	Input current	Iin	0	70	100	μA	$V_{in}=0$ to V_{fcs}	22	
		Iin	-10	0	+10	μA		5, 23, 24	
	Low level voltage	Vil	—	—	0.8	V			
	High level voltage	Vih	2.0	—	—	V			
Logic output	Low level voltage	Vol	0.08	0.15	0.4	V	$I_o=1\text{mA}$	15, 16	
	Leak current	Icer1	-10	—	+10	μA	$V_{ce}=15\text{V}$		
SPN driver	Output saturation voltage	Vsatspn	0.5	1.0	1.4	V	$I_{ospn}=1.0\text{A}$	32, 33, 34	7
	Leak current	Icer2	0	2.2	3.0	mA	$V_{ce}=15\text{V}$		
	Current limiter voltage	Vspncl	0.30	0.33	0.36	V		31	2
Logic input	Input current	Iinctl	-10	0	+10	μA	$V_{ctl}=0$ to V_{fcs}	4	
		Iinref	-20	0	+20	μA	$V_{REF}=2$ to 3	3	
	REF voltage range	Vref	2.0	—	3.0	V			
	Dead zone voltage	Vdzspn	± 50	± 75	± 100	mV	V_{ref} reference	3, 4	2
	Soft switch voltage range	Vsoft1	0.4	—	0.6	V	V_{ref} reference	4	3
		Vsoft2	—	2.0	—	Vp-p	VBEMF		
Current control gain	Gctl	-14	-12.5	-11	dB		3, 4, 31	2	

HA13558AFH

Electrical Characteristics ($T_a = 25^\circ\text{C}$, $V_{ps} = 12\text{V}$, $V_{spn} = 12\text{V}$, $V_{fcs} = 5\text{V}$, $V_{sld} = 12\text{V}$) (cont)

Item	Symbol	Min	Typ	Max	Unit	Test Conditions	Applicable Pins	Note
FCS &	Input current	linfcs	-2	0	+2	μA	$V_{fcsin}=0$ to V_{fcs}	3, 6, 7
TRR driver	Output saturation voltage	Vsatfcs	0.8	1.45	1.8	V	$I_o=0.33\text{A}$	8, 9,10,11
	Output quiescent voltage	Vqfcs	2.04	2.15	2.22	V	FCSIN=REF TRRIN=REF	
	Input conversion offset voltage	Vosfcs	-20	0	+20	mV		
	Voltage gain	Gvfcs	5	6	7	dB		
	Gain band width	Bfcs	100	200	—	kHz	$\Delta G_v=-3\text{dB}$	
SLD &	Output saturation voltage	Vsatsld	1.3	2.0	2.4	V	$I_{osld}=0.75\text{A}$	26, 27
TRY driver	Leak current	Icer3	-100	-10	0	μA	$V_{ce}=15\text{V}$	26 to 30
	Penetration current	Iovlap	0	0	100	mA		20 6
	Transient response time	tph1	0	0.2	5	μs		26 to 30
	Current limiter voltage	Vsldcl	0.297	0.33	0.363	V		28 4
SLD control	Input current	linsld	-10	0	+10	μA	$V_{sldin}=0$ to V_{fcs}	21
	Current control gain	Gsld	-14	-12.5	-11	dB		3, 21, 28 4
	Dead zone voltage	Vdzsld	± 50	± 75	± 100	mV	V_{ref} reference	
	Threshold voltage	Vthsld	1.7	2.0	2.3	V		25
	Charge current	Ichsld	44	50	56	μA	$R_{ref}=3.3\text{k}\Omega$	
Amplitude detection	VTH input voltage range	Vinth	0.3	—	1.8	V		14
	Input current	linco	-10	0	+10	μA	$V_{compain}=0$ to $V_{FCS}-0.3\text{V}$	13, 14 5
	Hysteresis	Vhysco	70	100	130	mV		
	Offset voltage	Vofco	-200	0	+200	mV		

Electrical Characteristics (Ta = 25°C, Vps = 12V, Vspn = 12V, Vfcs = 5V, Vsld = 12V) (cont)

Item	Symbol	Min	Typ	Max	Unit	Test Conditions	Applicable Pins	Note
CLK OSC	Reference voltage	Vr1	1.3	1.4	1.5	V	Rref=3.3kΩ	1
	Oscillation frequency	f _{CLK}	212	250	288	kHz	Rref=3.3kΩ, Cclk=100pF	48
Start-up circuit	Oscillation frequency	fcom	140	165	190	Hz	Rref=3.3kΩ, Ccom=0.1μF	47
	B-EMF Comp input sensitivity	Viemf	80	100	130	mV	BESENS=0V	32, 33,
40			52	70	mV	BESENS OPEN	34, 36	
OTSD	Operating temperature	Tsd	135	160	—	°C		6
	Hysteresis	Thys		50	—	°C		

- Note: 1. Ifcs shows a spec with the following conditions.
Vcompavth = 0V, Vctl = Vsldin = Vfcsin = Vtrrin = REF = 2.5V, Vtryin = 0V, Rref = 3.3kΩ, pin DDBST open.
2. See figure 1.

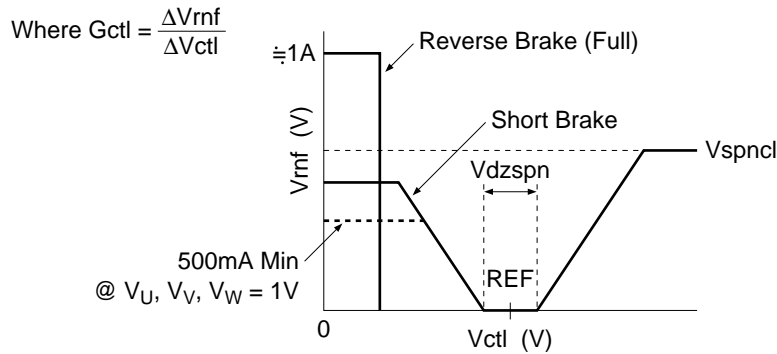

Figure 1

3. Figure 2 show how switching occurs in SW mode and in SOFT SW mode.

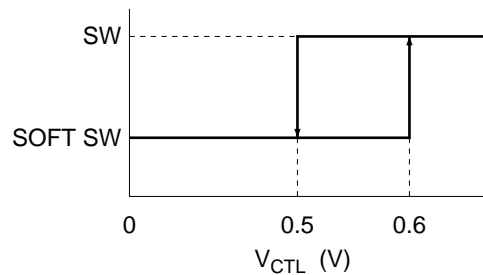

Figure 2

HA13558AFH

4. See figure 3.

$$\text{Where } G_{sld} = \frac{\Delta V_{rs}}{\Delta V_{sldin}}$$

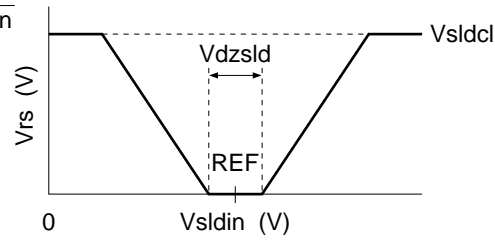

Figure 3

5. See figure 4.

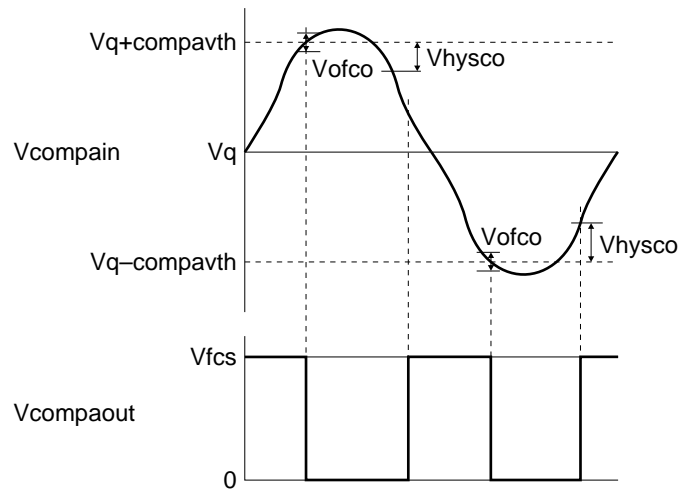

Figure 4

6. Design guide only.

7. When the W → U phase is powered: $V_{satspn} = 1.3V$ Typ, $\Delta 1.6V$ Max.

Package Dimensions

Unit: mm

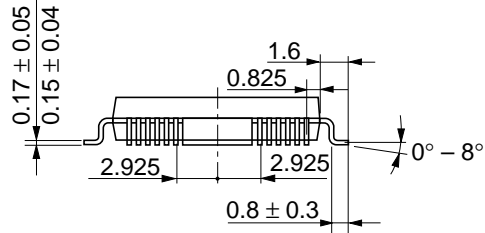
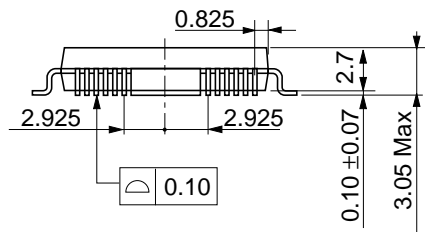
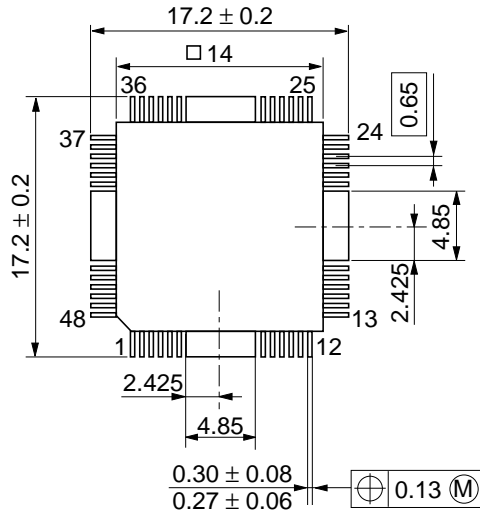

Dimension including the plating thickness
Base material dimension

Hitachi Code	FP-48T
JEDEC	—
EIAJ	—
Weight (reference value)	1.2 g

When using this document, keep the following in mind:

1. This document may, wholly or partially, be subject to change without notice.
2. All rights are reserved: No one is permitted to reproduce or duplicate, in any form, the whole or part of this document without Hitachi's permission.
3. Hitachi will not be held responsible for any damage to the user that may result from accidents or any other reasons during operation of the user's unit according to this document.
4. Circuitry and other examples described herein are meant merely to indicate the characteristics and performance of Hitachi's semiconductor products. Hitachi assumes no responsibility for any intellectual property claims or other problems that may result from applications based on the examples described herein.
5. No license is granted by implication or otherwise under any patents or other rights of any third party or Hitachi, Ltd.
6. **MEDICAL APPLICATIONS:** Hitachi's products are not authorized for use in **MEDICAL APPLICATIONS** without the written consent of the appropriate officer of Hitachi's sales company. Such use includes, but is not limited to, use in life support systems. Buyers of Hitachi's products are requested to notify the relevant Hitachi sales offices when planning to use the products in **MEDICAL APPLICATIONS**.

HITACHI

Hitachi, Ltd.

Semiconductor & IC Div.
Nippon Bldg., 2-6-2, Ohte-machi, Chiyoda-ku, Tokyo 100, Japan
Tel: Tokyo (03) 3270-2111
Fax: (03) 3270-5109

For further information write to:

Hitachi America, Ltd.
Semiconductor & IC Div.
2000 Sierra Point Parkway
Brisbane, CA. 94005-1835
U S A
Tel: 415-589-8300
Fax: 415-583-4207

Hitachi Europe GmbH
Electronic Components Group
Continental Europe
Dornacher StraÙe 3
D-85622 Feldkirchen
M nchen
Tel: 089-9 91 80-0
Fax: 089-9 29 30 00

Hitachi Europe Ltd.
Electronic Components Div.
Northern Europe Headquarters
Whitebrook Park
Lower Cookham Road
Maidenhead
Berkshire SL6 8YA
United Kingdom
Tel: 0628-585000
Fax: 0628-778322

Hitachi Asia Pte. Ltd.
16 Collyer Quay #20-00
Hitachi Tower
Singapore 0104
Tel: 535-2100
Fax: 535-1533

Hitachi Asia (Hong Kong) Ltd.
Unit 706, North Tower,
World Finance Centre,
Harbour City, Canton Road
Tsim Sha Tsui, Kowloon
Hong Kong
Tel: 27359218
Fax: 27306071

Copyright © Hitachi, Ltd., 1997. All rights reserved. Printed in Japan.