

3 PHASE CONTROLLER FOR DC BRUSHLESS MOTOR

Features:

- Up to 50 KHz PWM switching capability.
- No bootstrap capacitor.
- Trapezoidal 120° or 60° compatibility.
- Forward and reverse direction.
- Regeneration mode.
- Programmable over current shutdown.
- Programmable over temperature shutdown.
- E.S.D protection.
- Lead-free, RoHS compliant.

Application:

- E-bike
- Fan and pump
- Actuators system
- Compressor

Package:



Description:

The IR3230 is a three-phase brushless DC motor controller/driver with many integrated features. They provide large flexibility in adapting the IR3230 to a specific system requirement and simplify the system design.

Typical connection:

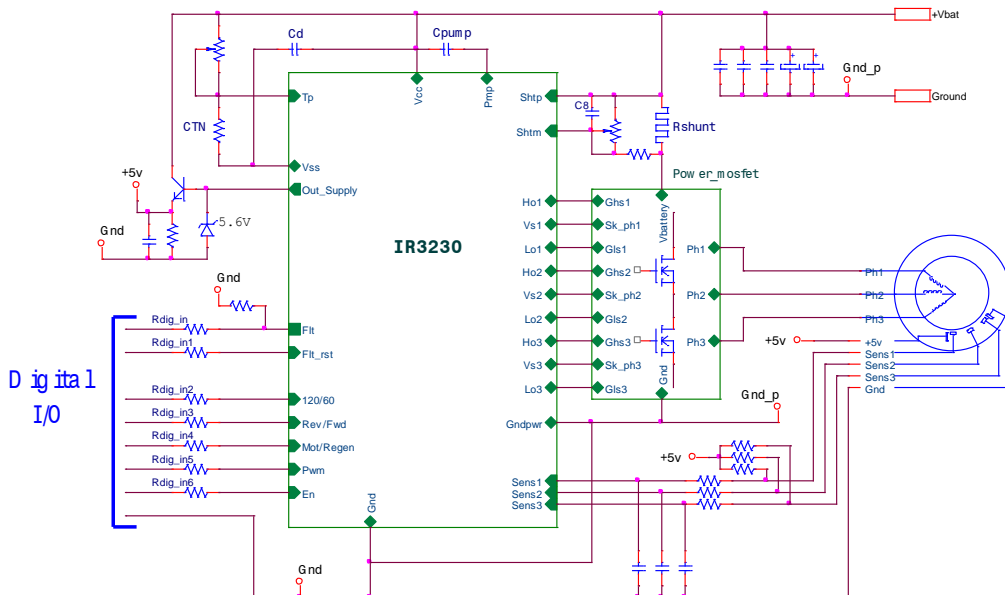

Qualification Information[†]

Qualification Level		<i>Industrial</i> ^{††}	
		<i>Comments: This family of ICs has passed JEDEC industrial qualification. IR's Consumer qualification level is granted by extension of the higher Industrial level.</i>	
Moisture Sensitivity Level		SOIC28W	MSL3260°C (per IPC/JEDEC J-STD-020)
ESD	<i>Machine Model</i>	Class A (per JEDEC standard JESD22-A115)	
	<i>Human Body Model</i>	Class 1C (per JEDEC standard JESD22-A114)	
	<i>Charged Device Model</i>	Class IV (per JEDEC standard JESD22-C101)	
IC Latch-Up Test		Class II, Level A (per JEDEC standard JESD78)	
RoHS Compliant		Yes	

† Qualification standards can be found at International Rectifier's web site <http://www.irf.com/>

†† Higher qualification ratings may be available should the user have such requirement. Please contact your International Rectifier sales representative for further information.

Absolute Maximum Ratings

Absolute maximum ratings indicate sustained limits beyond which damage to the device may occur. ($T_j = -40^{\circ}\text{C}..150^{\circ}\text{C}$, $V_{cc} = 6..65\text{V}$ unless otherwise specified).

Symbol	Parameter	Min.	Max.	Units
$V_{Gnd\ to\ Vcc}$	Maximum Gnd to Vcc voltage	-0.3	75	V
$V_{Gndpwr\ to\ Vcc}$	Maximum Gndpwr to Vcc voltage	-0.3	65	V
$V_{Gnd\ to\ Gndpwr}$	Maximum Gnd to Gndpwr voltage	-40	40	V
$V_{Latch\ test}$	Maximum power supply voltage to perform the latch test	—	50	V
$V_{Dig\ in\ to\ Vcc}$	Maximum all digital input to Vcc voltage	-0.3	75	V
$V_{Flt\ to\ Vcc}$	Maximum Flt to Vcc voltage	-0.3	75	V
$V_{Vsx\ to\ Vcc}$	Maximum Vsx to Vcc voltage	-1.5	75	V
$V_{Shtp\ to\ Vcc}$	Maximum Shtp to Vcc voltage	-0.3	0.3	V
$V_{Shtm\ to\ Vcc}$	Maximum Shtm to Vcc voltage	-0.3	75	V
$V_{Out_supply\ to\ Vcc}$	Maximum Out_supply to Vcc voltage	-0.3	75	V
$V_{Tp\ to\ Vcc}$	Maximum Tp to Vcc voltage	-0.3	75	V
I_{flt}	Maximum continous output current on the Flt pin	—	4	mA
$Pd\ 3230s$	Maximum power dissipation (1) $R_{th}=80^{\circ}\text{C}/\text{W}$	—	1.5	W
$T_j\ max.$	Max. storage & operating temperature junction temperature	-40	150	$^{\circ}\text{C}$

Thermal Characteristics

Symbol	Parameter	Typ.	Max.	Units
$R_{th}\ 3230s$	Thermal resistance junction to ambient	80	—	$^{\circ}\text{C}/\text{W}$

Recommended Operating Conditions

These values are given for a quick design. For operation outside these conditions, please consult the application notes.

Symbol	Parameter	Min.	Max.	Units
Vcc opp	Power supply voltage	6	60	V
Cpump	Charge pump capacitor	0.22	4.7	μ F
Max consumption Vss	Maximum consumption on the Vss		100	μ A
Cd	Recommended capacitor between Vcc and Vss	10	100	nF
R Dig in	Recommended resistor in series with digital input pin	0	10	k Ω
R pld Flt	Recommended pull down resistor on the Flt pin (no internal pull down)	1.5	-	k Ω
RVsx	Recommended resistor in series with high side source (recommended RVsx = RLox)	5	100	Ω
RLox	Recommended resistor in series with low side gate	5	100	Ω
F_Hox max	Maximum recommended high side MOSFET frequency (Hox-Vsx) load =2.2nF, Cpump = 220nF		2	kHz
F_Lox max	Maximum recommended low side MOSFET frequency Lox load =2.2nF, Cpump = 220nF		50	kHz

Static Electrical Characteristics

Tj=25°C, Vcc=48V (unless otherwise specified), Dig in = All except Hox, Lox, Vsx, Flt, Pmp, Tp, Shtp, Shtm, Vcc, Gnd, Gndpwr, Out_supply.

Symbol	Parameter	Min.	Typ.	Max.	Units	Test Conditions
I Gnd Slp	Supply current in low consumption mode	0.3	1	2	mA	En = 0;
I Gnd On	Gnd current when the device is awake	1.2	2.5	4	mA	En = 1;
I Out_supply	Out_supply output current	1	1.7	3.1	mA	Vout_Vcc >6V
I Flt	Flt pin output current	3	6.6	10	mA	Flt = Gnd when fault
V Flt	Flt pin output voltage	4.5	5	5.8	V	I Flt = 10 μ A
V dig_in Off	All digital input Low threshold voltage	0.6	1	1.6	V	
V dig_in On	All digital input High threshold voltage	1.9	2.8	3.8	V	
V dig_in Hyst	All digital input hysteresis	1.3	1.8	2.5	V	
I dig_in On	All digital input On state current	3.8	8	16	μ A	Vdig in= 5v
I sensor	All digital input On state current	8.8	18	36	μ A	Vsensx = ov
V Hox-Vsx	High side gate voltage	5.8	6.1	7	V	
V Lox	Low side gate voltage	5.8	6.5	11	V	
I Hox Out_Gndpwr	High side gate output current Vsx < Vcc	38	50	85	mA	Hox = Vsx
I Hox Out_Vcc	High side gate output current Vsx > Vcc	7	15	19	mA	Hox = Vsx
I Hox In	High side gate input current	70	110	250	mA	(Hox - Vsx)=6V, Vsx = Vcc
I Lox Out	Low side gate output current	250	350	700	mA	Lox = Gndpwr
I Lox In	Low side gate input current	250	350	700	mA	Lox = 6V

Switching Electrical Characteristics

$V_{CC}=48V$, $T_J=25^{\circ}C$ (unless otherwise specified)

Motor & Regen mode							
	Symbol	Parameter	Min.	Typ.	Max.	Units	Conditions
	C_{pump}	Time to charge the pump capacitor	1.5	5	8	ms	$C_{pump} = 220nF$ from $EN = hi$ to $(V_{cpump} - V_{CC}) = 5.3v$
	$T_{pwr_on_rst}$	Power on reset time	180	600	1200	μs	$C_{pump} = 6V$
High side	$Tr1$ Hox-Vsx	Rise time high side gate with $V_{sx} = gndpwr$	0.1	0.3	0.5	μs	(Hox-Vsx) load =2.2nF From 10% to 90%
	$Tr2$ Hox-Vsx	Rise time high side gate with $V_{sx} = V_{CC}$	0.8	2.5	5	μs	(Hox-Vsx) load =2.2nF From 10% to 90%
	$Tf1$ Hox-Vsx	Fall time high side gate with $V_{sx} = Gndpwr$	0.05	0.15	0.25	μs	(Hox-Vsx) load =2.2nF From 90% to 10%
	$Tf2$ Hox-Vsx	Fall time high side gate with $V_{sx} = V_{CC}$	0.15	0.7	1.4	μs	(Hox-Vsx) load =2.2nF From 90% to 10%
	$Td1$ MtoR Hox off	Motor to Regen mode High side turn-off delay time $V_{sx} = gndpwr$	0.1	0.3	0.5	μs	(Hox-Vsx) load =2.2nF from 50% of Reg/mot to 90% of (Hox - Vsx)
	$Td2$ MtoR Hox off	Motor to Regen mode High side turn-off delay time $V_{sx} = V_{CC}$	0.8	2.5	5	μs	(Hox-Vsx) load =2.2nF from 50% of Reg/mot to 90% of (Hox - Vsx)
	$Td1$ RtoM Hox on	Regen to Motor mode High side turn-on delay time $V_{sx} = gndpwr$	0.1	0.3	0.5	μs	(Hox-Vsx) load =2.2nF from 50% of Reg/mot to 10% of (Hox - Vsx)
	$Td2$ RtoM Hox on	Regen to Motor mode High side turn-on delay time $V_{sx} = V_{CC}$	0.8	2.5	5	μs	(Hox-Vsx) load =2.2nF from 50% of Reg/mot to 10% of (Hox - Vsx)
Low side	Tr Lox	Low side rise time to turn on	0.04	0.1	0.3	μs	Lox load =2.2nF From 10% to 90%
	Tf Lox	Low side fall time to turn off	0.04	0.1	0.3	μs	Lox load =2.2nF From 90% to 10%
	Td MtoR Lox on	Motor to Regen mode low side turn-on delay time	0.1	0.25	0.5	μs	Lox load =2.2nF from 50% of Reg/mot to 10% of Lox
	Td RtoM Lox off	Regen to Motor mode low side turn-off delay time	0.1	0.25	0.5	μs	Lox load =2.2nF from 50% of Reg/mot to 10% of Lox

Regen mode							
	Symbol	Parameter	Min.	Typ.	Max.	Units	Conditions
Low side	<i>Td Pwm Lox on</i>	<i>Pwm to low side turn-on delay time</i>	0.1	0.25	0.5	μs	<i>Lox load =2.2nF from 50% of Pwm to 10% of Lox</i>
	<i>Td Pwm Lox off</i>	<i>Pwm to low side turn-off delay time</i>	0.1	0.25	0.5	μs	<i>Lox load =2.2nF from 50% of Pwm to 90% of Lox</i>
Motor Mode							
	Symbol	Parameter	Min.	Typ.	Max.	Units	Conditions
High side	<i>Td1 Sensx Hox on</i>	<i>Sensor to high side turn-on delay time Vsx = gndpwr</i>	0.1	0.25	0.5	μs	<i>(Hox-Vsx) load =2.2nF from 50% of Sensx to 10% of (Hox - Vsx)</i>
	<i>Td2 Sensx Hox on</i>	<i>Sensor to high side turn-on delay time Vsx = Vcc</i>	0.8	2.5	5	μs	<i>(Hox-Vsx) load =2.2nF from 50% of Sensx to 10% of (Hox - Vsx)</i>
	<i>Td1 Sensx Hox off</i>	<i>Sensor to high side turn-off delay time Vsx = gndpwr</i>	0.1	0.25	0.5	μs	<i>(Hox-Vsx) load =2.2nF from 50% of Sensx to 90% of (Hox - Vsx)</i>
	<i>Td2 Sensx Hox off</i>	<i>Sensor to high side turn-off delay time Vsx = Vcc</i>	0.8	2	5	μs	<i>(Hox-Vsx) load =2.2nF from 50% of Sensx to 90% of (Hox - Vsx)</i>
Low side	<i>Td Pwm Lox on</i>	<i>Pwm to low side turn-on delay time</i>	0.1	0.25	0.5	μs	<i>Lox load =2.2nF from 50% of Pwm to 10% of Lox</i>
	<i>Td Pwm Lox off</i>	<i>Pwm to low side turn-off delay time</i>	0.1	0.25	0.5	μs	<i>Lox load =2.2nF from 50% of Pwm to 90% of Lox</i>
	<i>Td Sensx Lox on</i>	<i>Sensor to low side turn-off delay time</i>	0.1	0.25	0.5	μs	<i>Lox load =2.2nF from 50% of Sensx to 10% of Lox</i>
	<i>Td Sensx Lox off</i>	<i>Sensor to low side turn-off delay time</i>	0.1	0.25	0.5	μs	<i>Lox load =2.2nF from 50% of sensx to 90% of Lox</i>

Protection Characteristics

Vcc=48V, Tj=25°C (unless otherwise specified).

Symbol	Parameter	Min.	Typ.	Max.	Units	Conditions
<i>Vth Isd</i>	<i>Maximum over current shutdown threshold between Shtp and Shtm</i>	65	80	97	mV	<i>Rshunt =5 mΩ → Imax =20A</i>
<i>Vth Tsd</i>	<i>External over temperature threshold</i>	45	50	55	%	<i>(Vtemp-VSht+)/(Vss-VSht+)</i>
<i>Tsd int</i>	<i>Internal over temperature threshold</i> <i>Guaranteed by design</i>	150	165		°C	
<i>Dly Latch set</i>	<i>Delay to set the latch</i>	0.3	1	3	μs	<i>Delay fault from Vth(Isd) = 200mV</i>
<i>Dly Latch reset</i>	<i>Delay to reset the latch by Fit_rst pin</i>	5	25	60	μs	

UV Pump on	Shtp – Pmp charge pump under voltage on	4.9	5.3	5.75	V	
UV Pump off	Shtp – Pmp charge pump under voltage off	4.5	4.9	5.4	V	
UV Pump hyst	Shtp – Pmp charge pump under voltage hysteresis	0.2	0.37	0.6	V	
UV Vss	Vcc (Shtp)- Vss under voltage	3.9	4.8	5.7	V	
UV Vcc gnd	Vcc (Shtp)-Gnd under voltage	4.6	5.4	6	V	
UV Vcc gndpwr	Vcc-Gndpwp under voltage	4.6	5.4	6	V	

Lead Assignments 4.6

Part number						IR3230SPbF	
Lead assignments						 <i>SOIC-28L Wide Body</i>	
1	120/60	11	Shtm	21	Vs1		
2	Rev/Fwd	12	Tp	22	Ho2		
3	Mot/Regen	13	Vss	23	Vs2		
4	Pwm	14	Lo1	24	Ho3		
5	En	15	Lo2	25	Vs3		
6	Flt_rst	16	Lo3	26	Sens3		
7	Flt	17	Gndpwr	27	Sens2		
8	Out_supply	18	Vcc	28	Sens1		
9	Gnd	19	Pmp				
10	Shtp	20	Ho1				

Typical Schematic:

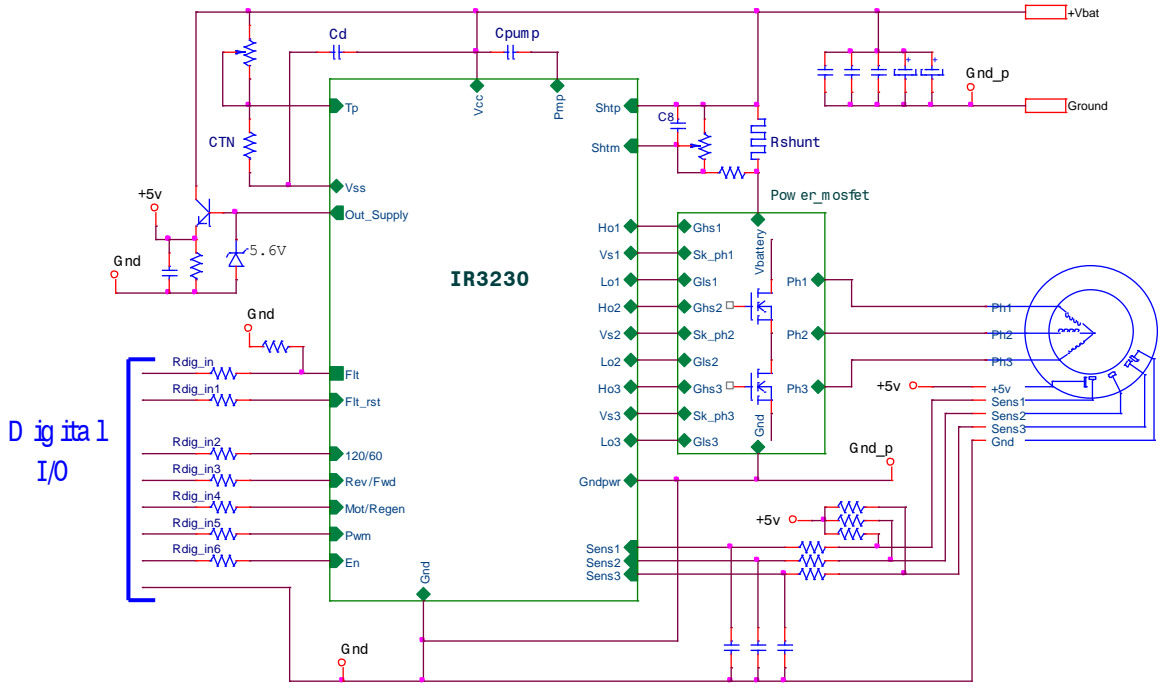

High side source connection for high current application:

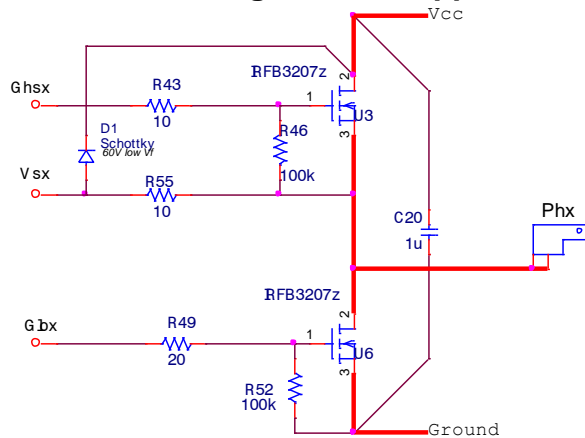

Functional Block Diagram

All values are typical

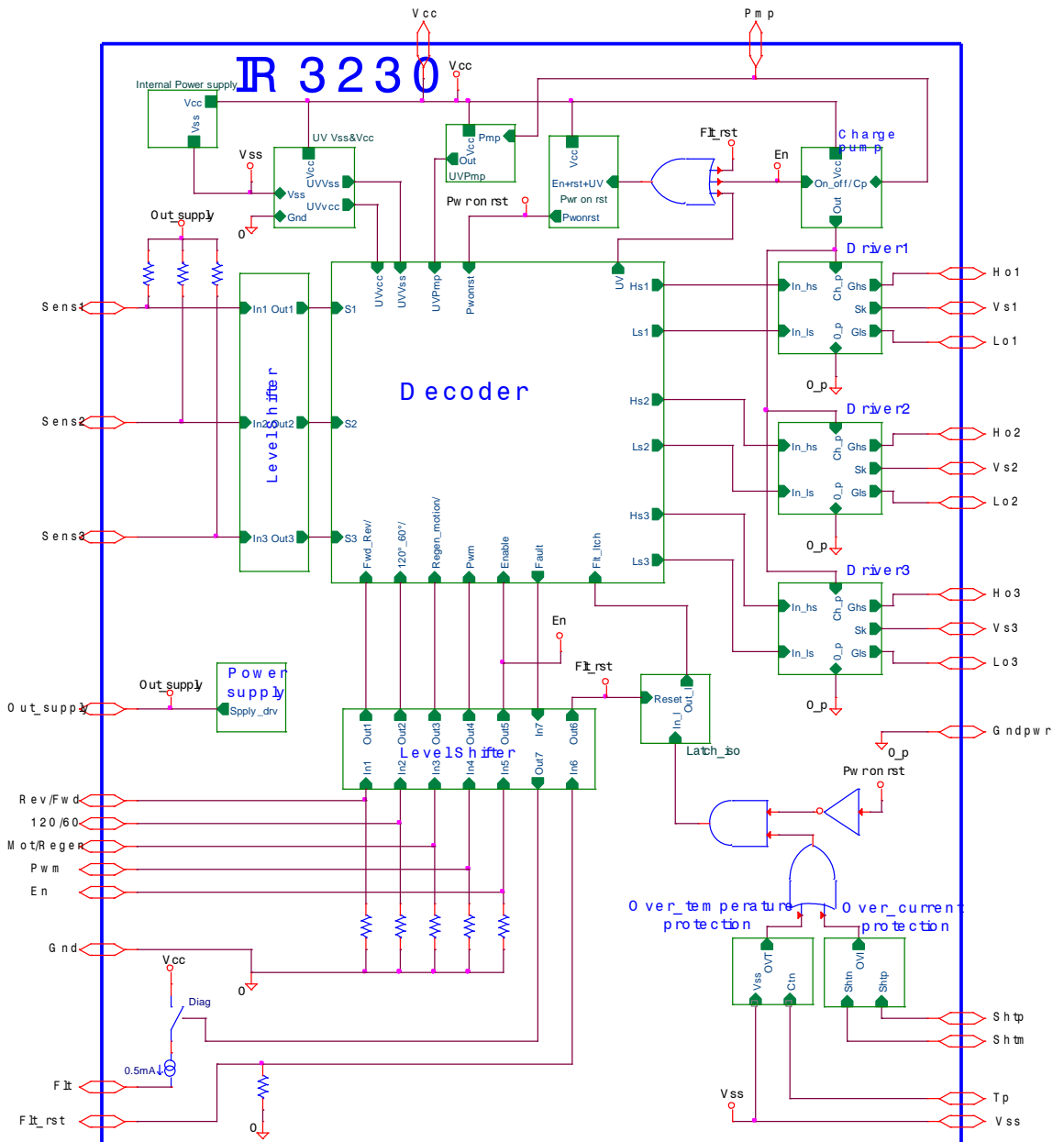

Simplified schematic:

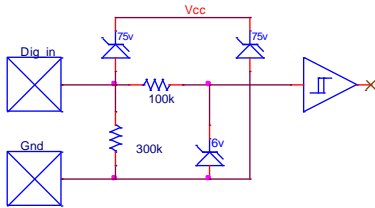

Figure 1: Digital input

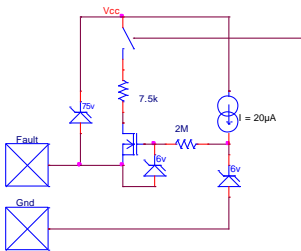

Figure 2: Fault output

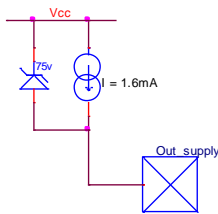

Figure 3: Out_supply

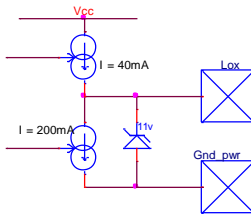

Figure 4: Lo output

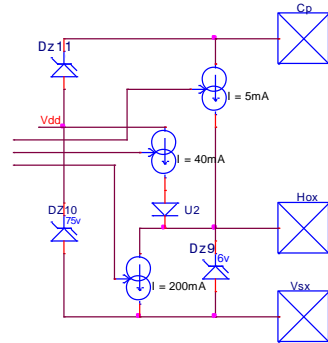

Figure 5: Hox output

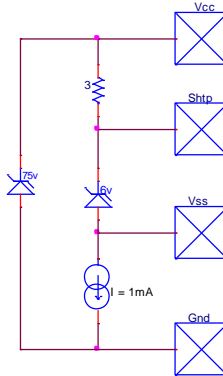

Figure 6: Vss pin

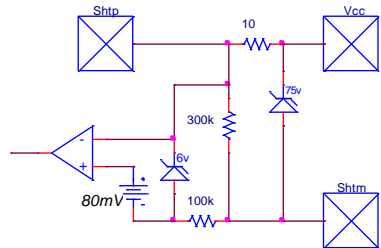

Figure 7: Sht_in

Decoder Table:

Inputs									Outputs						Motor				
Sensor electrical phasing			Operating mode selection						Diagnostic	Top drives			Bottom drives			Ph1	Ph2	Ph3	Direction
120/60 =0 ⇒60° mode	120/60 =1 ⇒120° mode																		
S1	S2	S3	S1	S2	S3	Rev/Fwd	Mot/Regen	En	Flt	Ho1	Ho2	Ho3	Lo1	Lo2	Lo3				
Motor mode																			
0	0	0	1	0	1	0	1	1	0	1	0	0	0	Pwm	0	1	0	Hz	Fwd direction
1	0	0	1	0	0	0	1	1	0	1	0	0	0	0	Pwm	1	Hz	0	
1	1	0	1	1	0	0	1	1	0	0	1	0	0	0	Pwm	Hz	1	0	
1	1	1	0	1	0	0	1	1	0	0	1	0	Pwm	0	0	0	1	Hz	
0	1	1	0	1	1	0	1	1	0	0	0	1	Pwm	0	0	0	Hz	1	
0	0	1	0	0	1	0	1	1	0	0	0	1	0	Pwm	0	Hz	0	1	
0	0	0	1	0	1	1	1	1	0	0	1	0	Pwm	0	0	0	1	Hz	Rev direction
1	0	0	1	0	0	1	1	1	0	0	0	1	Pwm	0	0	0	Hz	1	
1	1	0	1	1	0	1	1	1	0	0	0	1	0	Pwm	0	Hz	0	1	
1	1	1	0	1	0	1	1	1	0	1	0	0	0	Pwm	0	1	0	Hz	
0	1	1	0	1	1	1	1	1	0	1	0	0	0	0	Pwm	1	Hz	0	
0	0	1	0	0	1	1	1	1	0	0	1	0	0	0	Pwm	Hz	1	0	
Regen mode																			
x	x	x	x	x	x	x	0	1	0	0	0	0	Pwm	Pwm	Pwm	Buck converter	Generator		
Disable mode																			
x	x	x	x	x	x	x	x	0	0	0	0	0	0	0	0	Hz	Hz	Hz	Off
Fault mode																			
1	0	1	1	1	1	x	x	1	1	0	0	0	0	0	0	Hz	Hz	Hz	Off
0	1	0	0	0	0	x	x	1	1	0	0	0	0	0	0	Hz	Hz	Hz	

Keys	
x	Don't care
1	Active
0	not active
Hz	High impedance
Pwm	Signal on the pwm input

Fault Table:

latched fault	
Flt = 1	If $[V(\text{Sht}+) - V(\text{Sht}-)] > 80\text{mv}$
	or
	If $[V(\text{Vcc}) - V(\text{Tp})] > 50\%$ of $[V(\text{Vcc}) - V(\text{Vss})]$
	or
	If the sensor code is wrong

Not latched fault	
Flt = 1	If Flt_rst = 5v
	or
	If one of all UV is activated
	or
	If En is not activated
	or
	If the Tpwr_on_rst is activated

Logical equation:

1) 120° mode:

➤ *Forward direction:*

- | | |
|------------------------------------|------------------------------------|
| ○ $Ho1 = S1 \bullet \overline{S2}$ | ○ $Lo1 = \overline{S1} \bullet S2$ |
| ○ $Ho2 = S2 \bullet \overline{S3}$ | ○ $Lo2 = \overline{S2} \bullet S3$ |
| ○ $Ho3 = S3 \bullet \overline{S1}$ | ○ $Lo3 = \overline{S3} \bullet S1$ |

➤ *Reverse direction:*

- | | |
|------------------------------------|------------------------------------|
| ○ $Ho1 = \overline{S1} \bullet S2$ | ○ $Lo1 = S1 \bullet \overline{S2}$ |
| ○ $Ho2 = \overline{S2} \bullet S3$ | ○ $Lo2 = S2 \bullet \overline{S3}$ |
| ○ $Ho3 = \overline{S3} \bullet S1$ | ○ $Lo3 = S3 \bullet \overline{S1}$ |

2) 60° mode:

➤ *Forward direction:*

- | | |
|---|---|
| ○ $Ho1 = \overline{S2} \bullet \overline{S3}$ | ○ $Lo1 = S2 \bullet S3$ |
| ○ $Ho2 = S1 \bullet S2$ | ○ $Lo2 = \overline{S1} \bullet \overline{S2}$ |
| ○ $Ho3 = \overline{S1} \bullet S3$ | ○ $Lo3 = S1 \bullet \overline{S3}$ |

➤ *Reverse direction:*

- | | |
|---|---|
| ○ $Ho1 = S2 \bullet S3$ | ○ $Lo1 = \overline{S2} \bullet \overline{S3}$ |
| ○ $Ho2 = \overline{S1} \bullet \overline{S2}$ | ○ $Lo2 = S1 \bullet S2$ |
| ○ $Ho3 = S1 \bullet \overline{S3}$ | ○ $Lo3 = \overline{S1} \bullet S3$ |

Shtp & Shtm, over Current protection:

The IR3230 has shunt interface input: Shtp & Shtm. This shunt measurement is referenced to the Vcc (measurement on the battery line). Thanks to the shunt value and an external divider resistor, the user can adjust the maximum current in the motor. The internal threshold is Vth Isd. This protection is latched so the Flt output is activated (High state) to provide a diagnostic to the μP . This protection can be reset by activating Flt_rst high for more than Trst time. This protection works only in the motor mode.

Tp & Vss, over temperature protection:

The IR3230 has CTN interface input: Tp, Vss. This CTN is referenced to the Vss. Thanks to an external resistor in series with the CTN resistor; the user can adjust the maximum temperature threshold. The internal threshold is Vth Tsd. This protection is latched so the Flt output is activated (high state) to provide a diagnostic to the μP . This protection can be reset by activating Flt_rst high for more than Trst time.

Mot/Regen:

This digital input allows selecting the motor mode or the regeneration mode (braking mode). The μP needs to implement a delay to switch from one to the other to avoid shoot through short circuit and activate the over current fault. This can be calculating by using the "Td xxx xx" parameters in the Switching electrical characteristics. Use the following parameters as a simple rule:

- Delay to go from the motor mode to the regen mode: use the maximum of the Td2 MtoR Hox off + the maximum of the Tf2_Hox-Vsx parameter.
- Delay to go from the regen mode to the motor mode: use the maximum of the Td1 RtoM Lox off + the maximum of the Tf Lox parameter.

Pwm:

In motion mode, through the pwm input, the μP controls the speed of the motor. This input provides duty cycle and the frequency to the low side switches in order of the sensor table selected by logical sensor input.

In regen mode (buck converter operation), It provides the duty cycle and the frequency to the 3 low side switches in same time independently of the sensor input sequence. So the μP can controls the regeneration current level in the battery and breaking the motor.

En:

The input Pin enable allows switching off all output power Mosfets and the Charge pump. This reduces the consumption of the device. The Out_supply output stays active to power supply the μP even if the Enable is set at 0V. En pin high wake up the device. When the voltage of charge pump capacitor reaches the UV pump threshold, the device wait for the power reset (Pwr on rst) and then it is ready to operate.

120/60°:

This digital input selects the right sensor table in order to the sensor electrical position 120° or 60°.

Out_supply:

This output provides a 1.6mA regulated current. This output can be used as a biasing to create a power supply thanks to an external zener diode and a bipolar ballast transistor. The created voltage of this power supply is defined by the value of the zener diode implemented. This power supply could be used to supply all external circuitries (Sensor, μP ...).

Rev/Fwd:

This digital input selects the right sensor table in order to choose the motor direction forward and reverse.

Fault:

A minimum pull down resistor to gnd must be used to limit the current on this output. Please refer to the Absolute maximum ratings table. There is no internal pull down: value is undefined when not in fault if no external pull down resistor is used.

Refer to Fault table to check witch event will be latched or not.

Parameters curves:

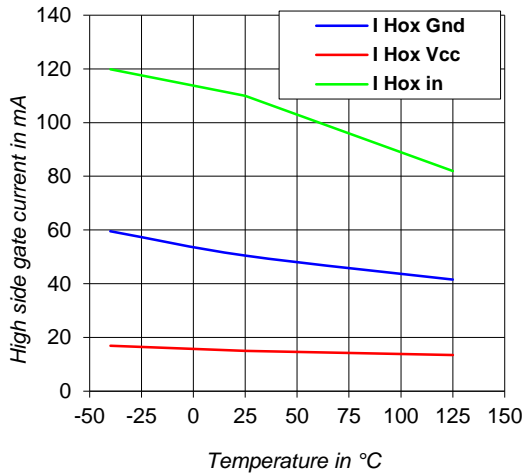

Figure 1: High side gate current vs. temperature

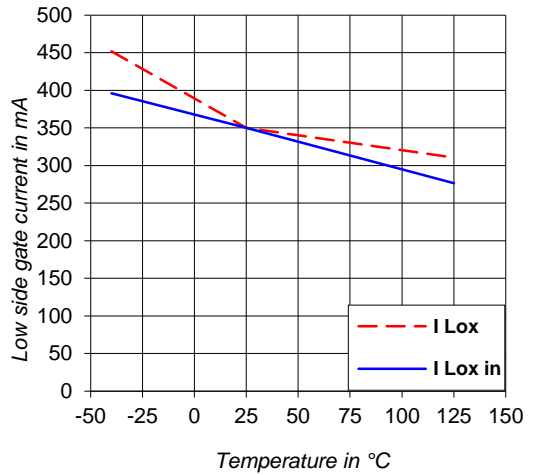

Figure 2: Low side gate current vs. temperature

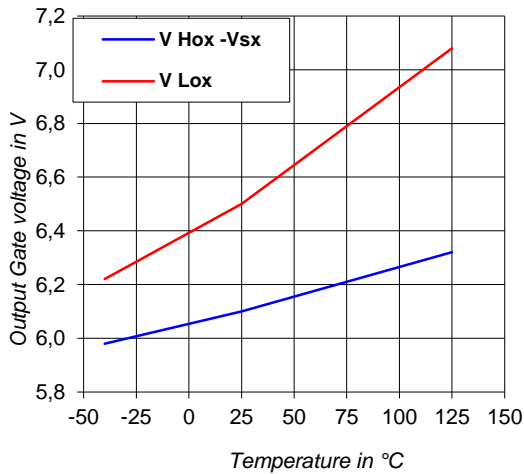

Figure3: Output gate voltage vs. temperature

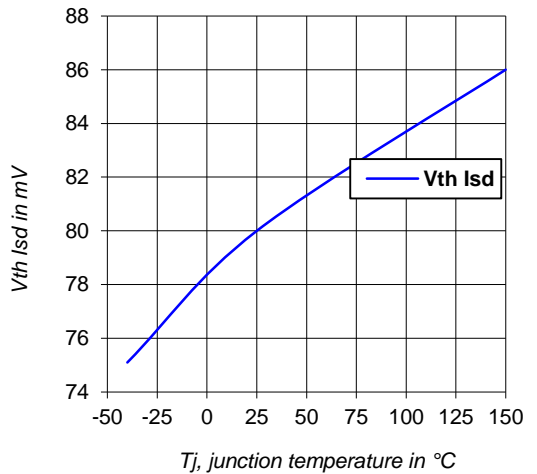
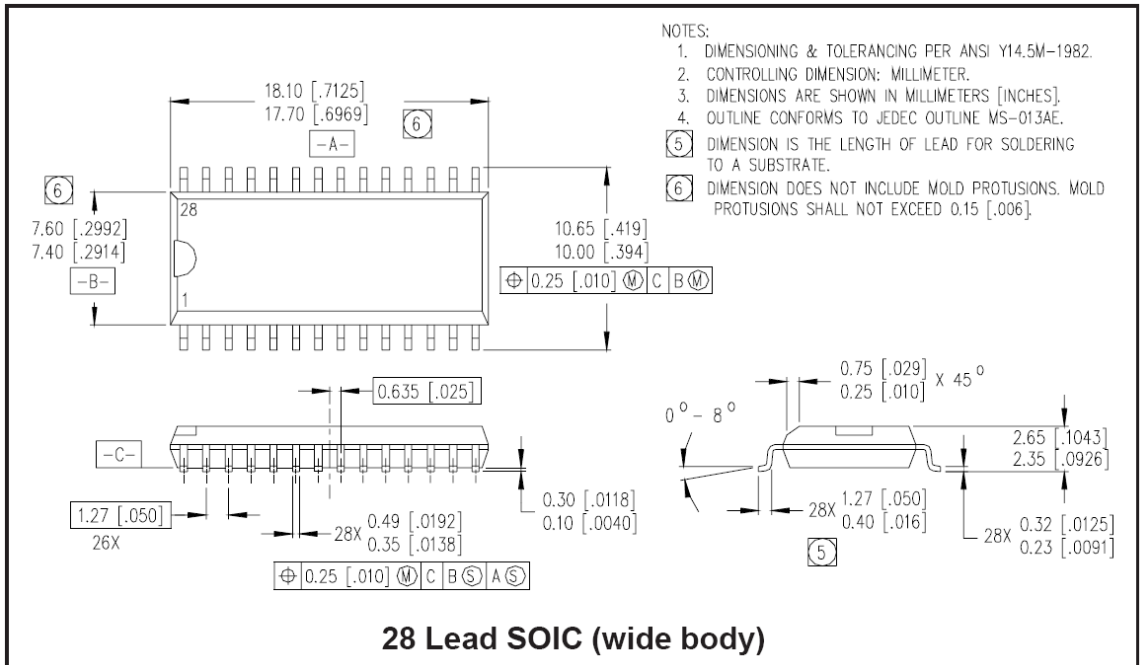
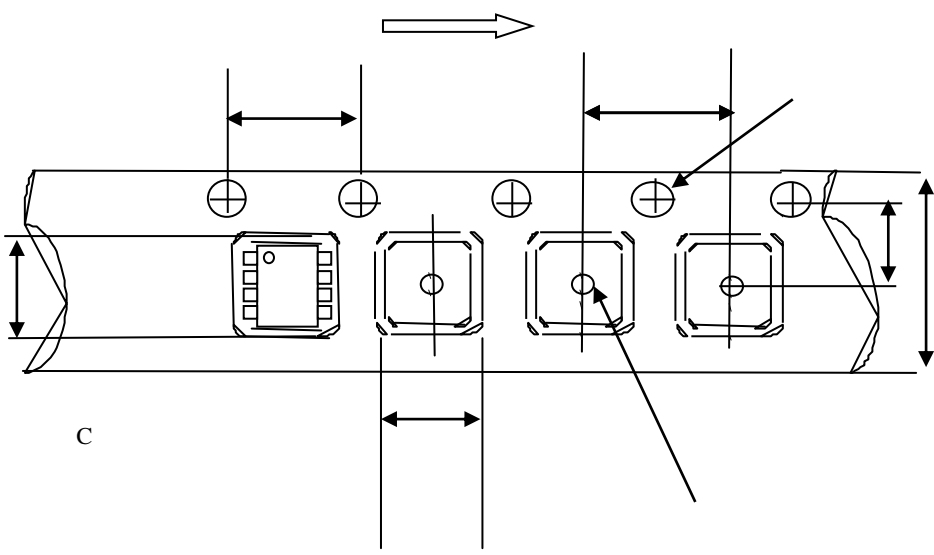

Figure4: Vth Isd Vs Tj

Package outline:





CARRIER TAPE DIMENSION FOR 28SOICW

Code	Metric		Imperial	
	Min	Max	Min	Max
A	11.90	12.10	0.468	0.476
B	3.90	4.10	0.153	0.161
C	23.70	24.30	0.933	0.956
D	11.40	11.60	0.448	0.456
E	10.80	11.00	0.425	0.433
F	18.20	18.40	0.716	0.724
G	1.50	n/a	0.059	n/a
H	1.50	1.60	0.059	0.062

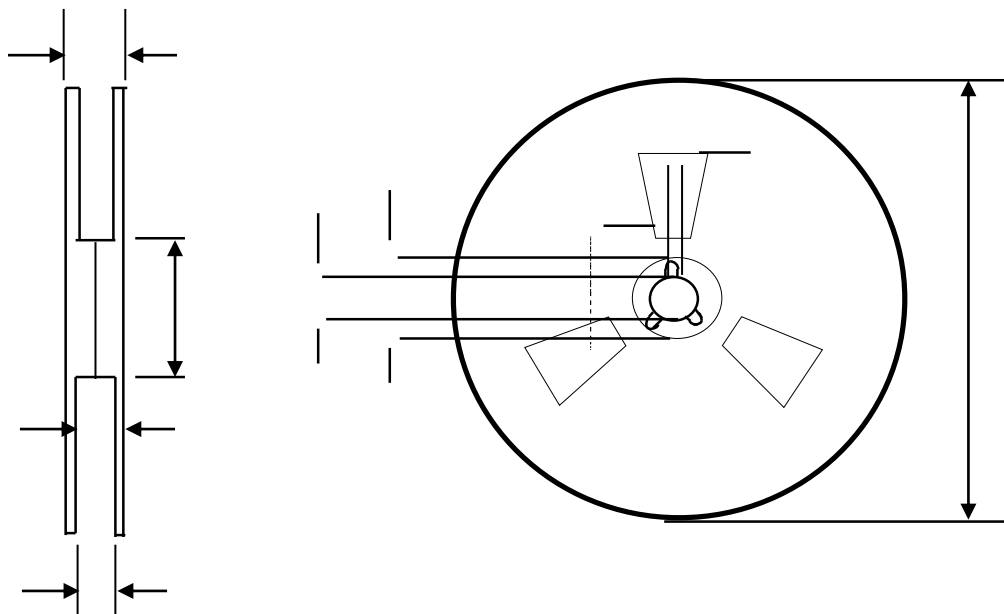

REEL DIMENSIONS FOR 28SOICW

Code	Metric		Imperial	
	Min	Max	Min	Max
A	329.60	330.25	12.976	13.001
B	20.95	21.45	0.824	0.844
C	12.80	13.20	0.503	0.519
D	1.95	2.45	0.767	0.096
E	98.00	102.00	3.858	4.015
F	n/a	30.40	n/a	1.196
G	26.50	29.10	1.04	1.145
H	24.40	26.40	0.96	1.039

Part Marking Information

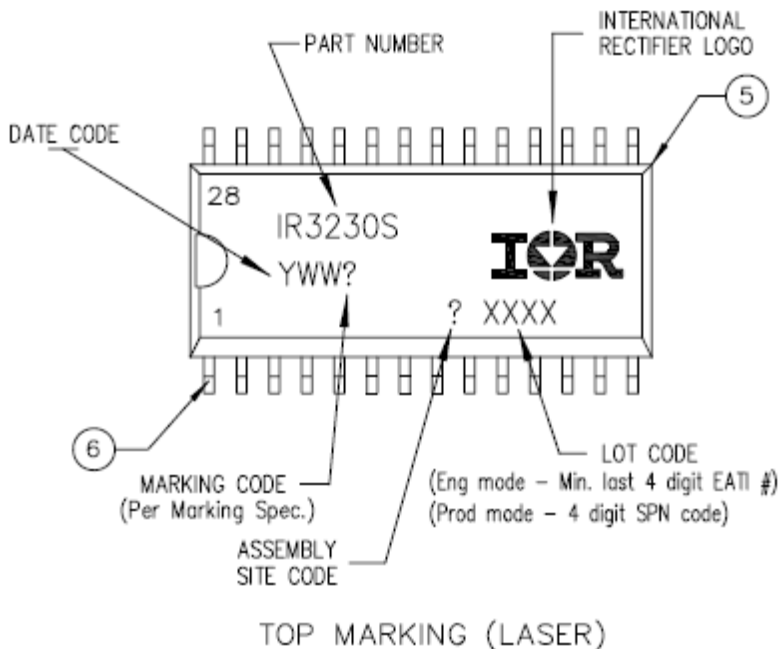

Ordering Information

Base Part Number	Package Type	Standard Pack		Complete Part Number
		Form	Quantity	
IR3230SPBF	SOIC28W	Tube/Bulk	25	IR3230SPBF
		Tape and Reel	1000	IR3230STRPBF

IMPORTANT NOTICE

Unless specifically designated for the automotive market, International Rectifier Corporation and its subsidiaries (IR) reserve the right to make corrections, modifications, enhancements, improvements, and other changes to its products and services at any time and to discontinue any product or services without notice. Part numbers designated with the "AU" prefix follow automotive industry and / or customer specific requirements with regards to product discontinuance and process change notification. All products are sold subject to IR's terms and conditions of sale supplied at the time of order acknowledgment.

IR warrants performance of its hardware products to the specifications applicable at the time of sale in accordance with IR's standard warranty. Testing and other quality control techniques are used to the extent IR deems necessary to support this warranty. Except where mandated by government requirements, testing of all parameters of each product is not necessarily performed.

IR assumes no liability for applications assistance or customer product design. Customers are responsible for their products and applications using IR components. To minimize the risks with customer products and applications, customers should provide adequate design and operating safeguards.

Reproduction of IR information in IR data books or data sheets is permissible only if reproduction is without alteration and is accompanied by all associated warranties, conditions, limitations, and notices. Reproduction of this information with alterations is an unfair and deceptive business practice. IR is not responsible or liable for such altered documentation. Information of third parties may be subject to additional restrictions.

Resale of IR products or serviced with statements different from or beyond the parameters stated by IR for that product or service voids all express and any implied warranties for the associated IR product or service and is an unfair and deceptive business practice. IR is not responsible or liable for any such statements.

IR products are not designed, intended, or authorized for use as components in systems intended for surgical implant into the body, or in other applications intended to support or sustain life, or in any other application in which the failure of the IR product could create a situation where personal injury or death may occur. Should Buyer purchase or use IR products for any such unintended or unauthorized application, Buyer shall indemnify and hold International Rectifier and its officers, employees, subsidiaries, affiliates, and distributors harmless against all claims, costs, damages, and expenses, and reasonable attorney fees arising out of, directly or indirectly, any claim of personal injury or death associated with such unintended or unauthorized use, even if such claim alleges that IR was negligent regarding the design or manufacture of the product.

Only products certified as military grade by the Defense Logistics Agency (DLA) of the US Department of Defense, are designed and manufactured to meet DLA military specifications required by certain military, aerospace or other applications. Buyers acknowledge and agree that any use of IR products not certified by DLA as military-grade, in applications requiring military grade products, is solely at the Buyer's own risk and that they are solely responsible for compliance with all legal and regulatory requirements in connection with such use.

IR products are neither designed nor intended for use in automotive applications or environments unless the specific IR products are designated by IR as compliant with ISO/TS 16949 requirements and bear a part number including the designation "AU". Buyers acknowledge and agree that, if they use any non-designated products in automotive applications, IR will not be responsible for any failure to meet such requirements.

For technical support, please contact IR's Technical Assistance Center
<http://www.irf.com/technical-info/>

WORLD HEADQUARTERS:

101 N. Sepulveda Blvd., El Segundo, California 90245
Tel: (310) 252-7105

Revision History

Revision	Date	Notes/Changes
<i>A</i>	<i>26/03/12</i>	<i>First release</i>
<i>B</i>	<i>August 7, 2012</i>	<i>Typo correction front page</i>