

# LR5810

## Description

The LR5810 series switcher ICs cost effectively replace all power supplies up to 5W output power based on unregulated isolated linear transformer (50/60HZ). Unlike conventional PWM (pulse width modulation) controllers, they regulate the output voltage in a new method of off-time modulation control. The controller consists of a VCO (voltage control oscillator), Sense and logic circuit, VDD pin, under-voltage lockout circuit, protection for over-voltage, current limited circuit, leading edge blanking, over load protection and fault condition auto-restart. They are ideal low power AC/DC adapter/charger solution for portable devices,

## Features

- Low start-up current: Typ.15  $\mu$ A Max.25  $\mu$ A
- UVLO(under voltage lockout):Typ.12V start-up Typ.6V shut-down
- Low operating current:Typ.2 mA Max.5 mA
  - LEB(leading edge blanking): Typ.300ns
  - OVP(over voltage protection): Typ.28 V
  - Operation Frequency: Typ.54KHZ(VDD=21V)
  - Output Driver Ability: Typ.15 mA
  - OLP(over load protection)
  - Universal AC input range
  - Constant voltage and constant current
  - Small SOT-23-6 and SOP-8 package.

## Applications

? AC/DC adapter/charger for cell/cordless phones, digital cameras, MP3/portable audio devices etc

- LED Lighting
- Replacements for linear transformers and RCC SMTPS

## Package

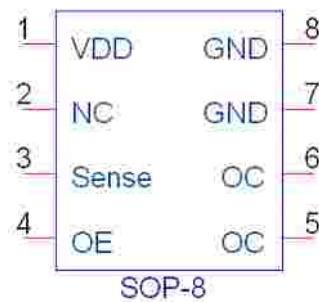
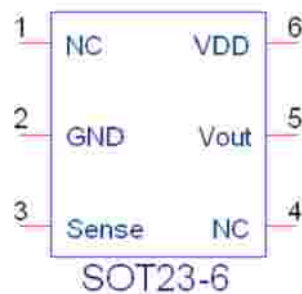

# LR5810

## Application Circuit

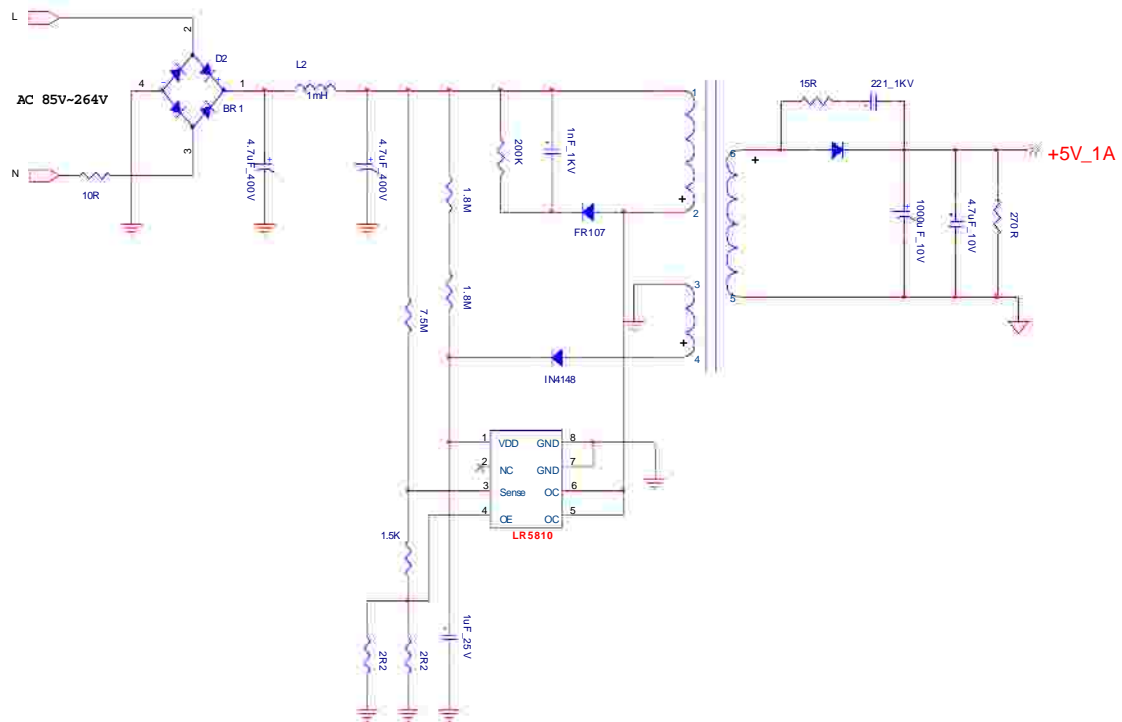
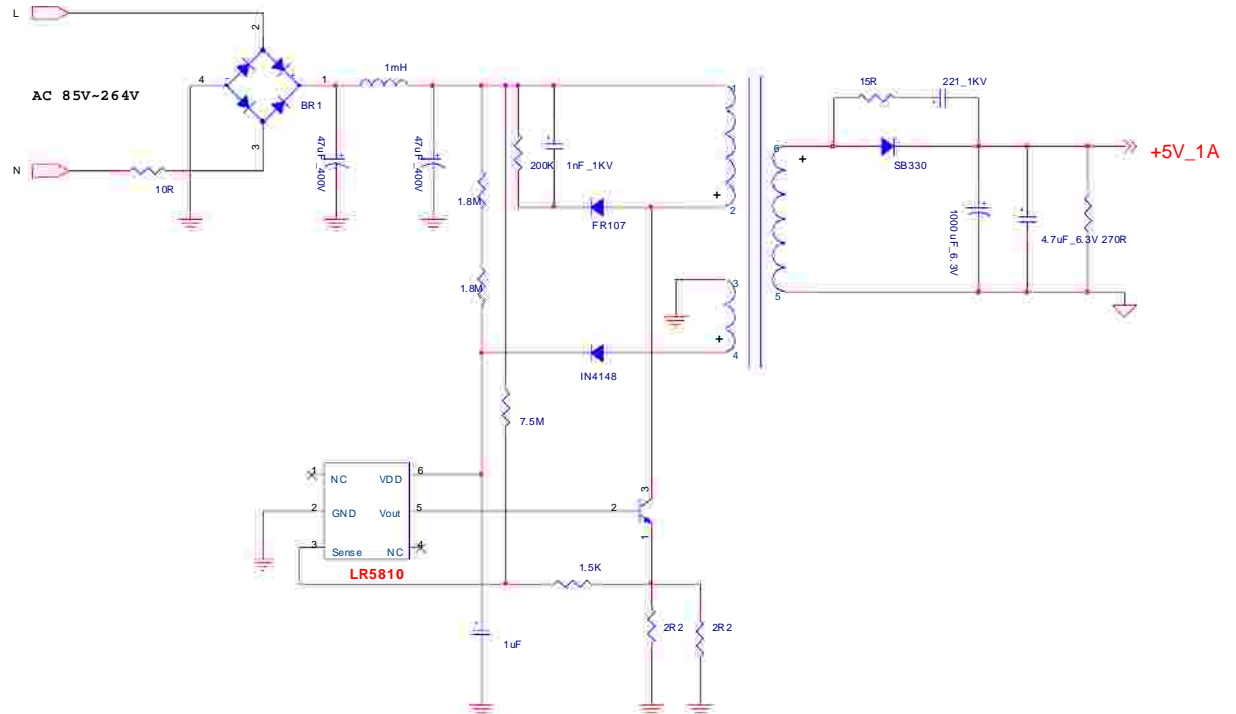

SOP-8 Application Circuit

## Block Diagram

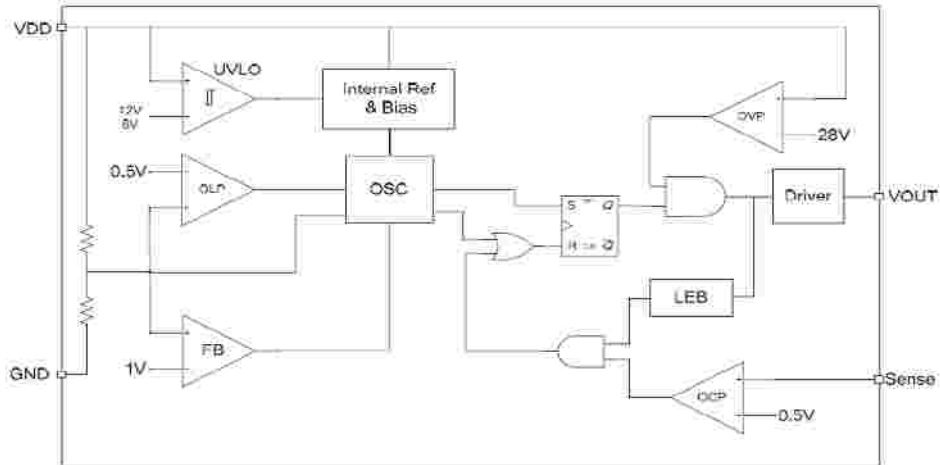

## Pin Connection (Top View)

Package	Function	Description
	PIN 1: NC	Not Connected
	PIN 2: GND	Ground
	PIN 3: Sense	Current sensor, it senses the voltage via a sensed resistor
	PIN 4: NC	Not Connected
	PIN 5: Vout	Gate drive output for the external power BJT switch.
	PIN 6: VDD	Power Supply
Package	Function	Description
	PIN 1: VDD	Power Supply
	PIN 2: NC	Not Connected
	PIN 3: Sense	Current sensor, it senses the voltage via a sensed resistor
	PIN 4: OE	Emitter Pin of the power BJT switch.
	PIN 5, 6: OC	Output Pin( Connect to switching transformer)
	PIN 7, 8: GND	Ground

## Function Description

### 1. Under Voltage Lockout

The turn-on and turn-off thresholds of the LR5810 are fixed internally at 12V/6V. During start-up, the hold-up capacitor must be charged to 12V through the start-up resistor, so that the LR5810 can be enabled. The hold-up capacitor will continue to supply VDD until power can be delivered from the auxiliary winding of the main transformer. When VDD drops below 6V, IC will be shut-down, and have to start-up again. This UVLO hysteretic window ensures that LR5810 can start-up very well.

### 2. Leading Edge Blanking

When the power BJT is switched on, a voltage spike will inevitably occur at the sense pin. To avoid premature termination of the switching pulse, a 300 ns leading-edge blanking time is built in LR5810. Conventional RC filtering can be omitted. During this blanking period, the current-limit comparator is disabled and it cannot switch off the gate driver.

### 3. Voltage Control Oscillator

The sense circuit of LR5810 series will sense the voltage of VDD pin (also the power pin of LR5810) and then control the frequency of the oscillator. The max frequency of LR5810 series is set to the rated output power point, for example LR5810 is set to 54 KHZ. Two signals are generated from the oscillator: the maximum duty cycle signal (DC max) and the clock signal that indicates the beginning of each switching cycle.

### 4. Sense Circuit

A resistor voltage divider circuit is connected between the VDD pin and GND pin in order to sample the feedback voltage at VDD pin. When the voltage of VDD pin exceeds 21V, IC will come into constant voltage control mode, shut-down the output pin and start a bypass circuit. This bypass circuit is linearly controlled by the feedback voltage. When the voltage of VDD pin falls below 21V, the off-time linearly increases in order to have a constant current output.

### 5. Gate Output

Unlike other chips, LR5810 used a constant current circuit to drive the output BJT. The output current is fixed at 15mA, select the appropriate HFE of BJT could have a different output power.

### 6. Fault Condition Auto-restart

In the event of a fault condition such as output over-load or short circuit, LR5810 series enter into auto-restart operation. It is using the turn-on and turn-off threshold again. LR5810 series are working in start mode to protect the system from damage caused by the fault condition.

### 7. Current Limit

The current through the power BJT is detected by the current limit circuit. Then the current flows through the sense-resistor and makes the voltage on Sense pin ramp up. And when this voltage exceeds the internal threshold (Vlimit), the power BJT is turned off immediately.



## Electrical Characteristic

Item	Conditions	MIN.	TYP.	MAX.	Unit
<b>Supply Voltage</b>					
Start-up Current	VDD=VDD(ON)-0.1		15	25	uA
Operation Voltage	25		21		V
Turn-on Threshold Voltage	VDD ON	11	12	13	V
Turn-off Threshold Voltage	VDD OFF	5.5	6	6.5	V
Over-voltage Thershold	Vovp		28	30	V
<b>Oscillator</b>					
Operation Frequency	25	45	50	55	KHZ
Duty Cycle	Vsense=0			75	%
Green Mode Frequency	25	15	20	25	KHZ
<b>Current Sensing</b>					
Leading Edge Blanking	25	250	300	350	nS
Current Sense Detection Voltage	VDD=15V	0.45	0.5	0.55	V
<b>Else</b>					
Output Delay Time	25		150		nS
Output Driver Current	25	12	15	18	mA

## Absolute Maximum Ratings

Item	Symbol	Value	Unit
VDD pin input voltage	VDD	40	V
SENSE pin input voltage	VSENSE	7	V
Power Dissipation	PD	400	mW
Operating Junction Temperature	TJ	-40 to +125	°C
Storage Temperature Range	TSTJ	-55 to +150	°C
Lead temperature	TL	260	°C

**Attention:** Stresses beyond those listed under "absolute maximum ratings" may cause permanent damage to the device. Exposure to absolute-maximum-rated conditions for extended periods may affect device reliability.

## Ordering info

LR5810-AL	SOT-26
LR5810-BL	SOP-8 内置三极管 13003

## SOT-26 Dimension

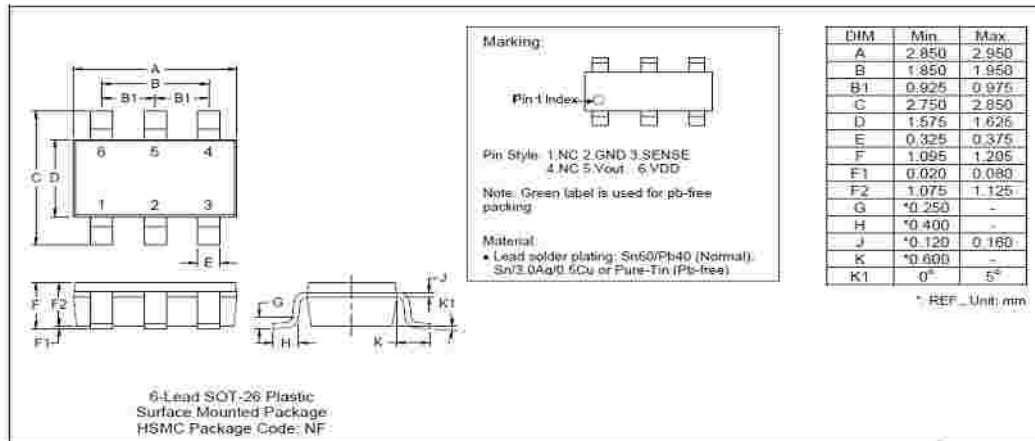

## SOP-8 Dimension

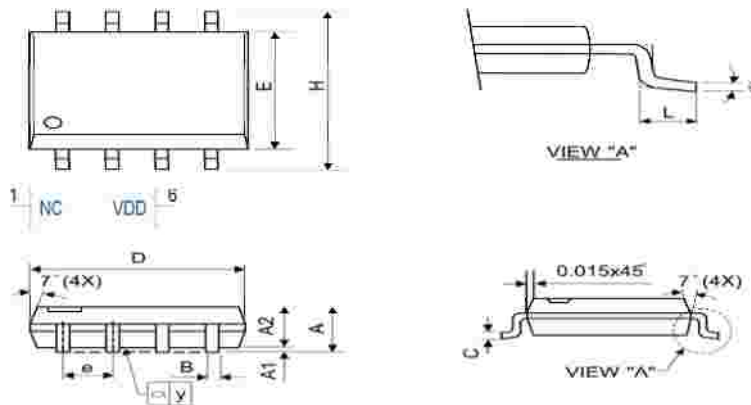

Symbol	Dimensions In Millimeters			Dimensions In Inches		
	Min.	Nom.	Max.	Min.	Nom.	Max.
A	1.40	1.60	1.75	0.055	0.063	0.069
A1	0.10	-	0.25	0.040	-	0.100
A2	1.30	1.45	1.50	0.051	0.057	0.059
B	0.33	0.41	0.51	0.013	0.016	0.020
C	0.19	0.20	0.25	0.0075	0.008	0.010
D	4.80	5.05	5.30	0.189	0.199	0.209
E	3.70	3.90	4.10	0.146	0.154	0.161
e	-	1.27	-	-	0.050	-
H	5.79	5.99	6.20	0.228	0.236	0.244
L	0.38	0.71	1.27	0.015	0.028	0.050
y	-	-	0.10	-	-	0.004
?	0°	-	8°	0°	-	8°