

Pin Configuration

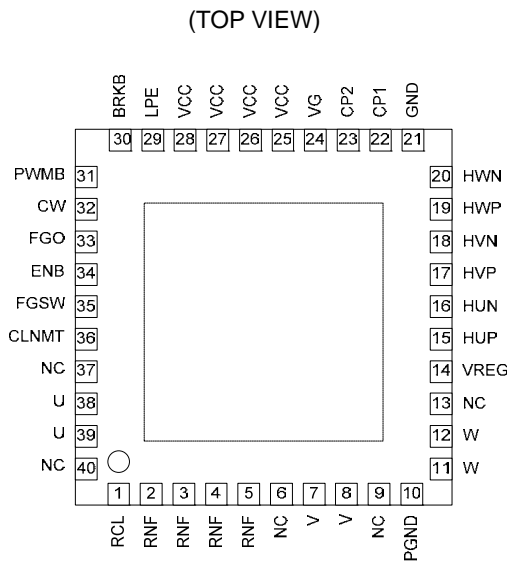

Figure 2. Pin Configuration

Block Diagram

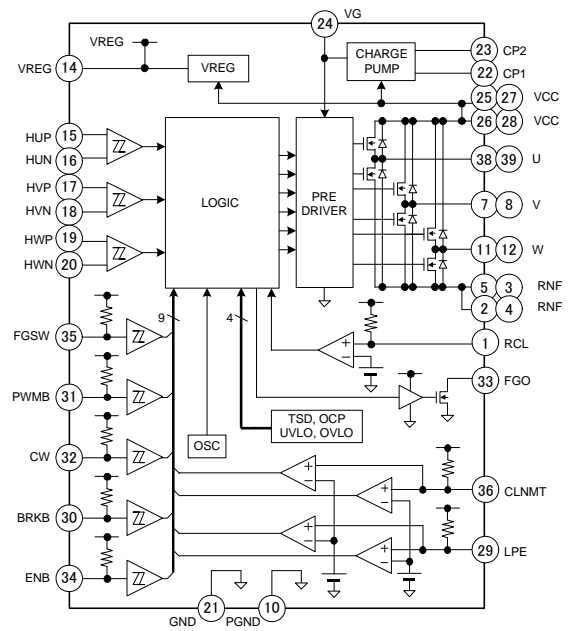

Figure 3. Block Diagram

Pin Description

Pin No.	Pin Name	Function	Pin No.	Pin Name	Function
1	RCL	Detect voltage input for over current	21	GND	Ground
2	RNF	Detect resistor for over current	22	CP1	Charge pump setting 1
3	RNF	Detect resistor for over current	23	CP2	Charge pump setting 2
4	RNF	Detect resistor for over current	24	VG	Charge pump output
5	RNF	Detect resistor for over current	25	VCC	Power supply
6	NC	NC	26	VCC	Power supply
7	V	V phase output	27	VCC	Power supply
8	V	V phase output	28	VCC	Power supply
9	NC	NC	29	LPE	Setting about motor lock protection (H/M/L input)
10	PGND	Ground	30	BRKB	Brake input (negative logic)
11	W	W phase output	31	PWMB	PWM input (negative logic)
12	W	W phase output	32	CW	CW/CCW input (H: CW, L: CCW)
13	NC	NC	33	FGO	FG output (1FG or 3FG)
14	VREG	Regulator output (OFF at stand-by)	34	ENB	Enable input (negative logic)
15	HUP	U phase Hall input +	35	FGSW	1FG/3FG switching (H: 3FG, L: 1FG)
16	HUN	U phase Hall input -	36	CLNMT	Current limit mask time setting (H/M/L input)
17	HVP	V phase Hall input +	37	NC	NC
18	HVN	V phase Hall input -	38	U	U phase output
19	HWP	W phase Hall input +	39	U	U phase output
20	HWN	W phase Hall input -	40	NC	NC

Absolute Maximum Ratings (Ta = 25°C)

Item	Symbol	Limit	Unit
Power Supply Voltage	V _{CC}	-0.3 to +33.0	V
VG Voltage	V _G	-0.3 to +38.0	V
Control Input Voltage	V _{IN} , V _{IN2}	-0.3 to +5.5	V
FGO Terminal Voltage	V _{FGO}	-0.3 to +7.0	V
RNF Maximum Apply Voltage	V _{RNF}	0.7	V
VREG Output Current	I _{VREG}	-30 ^(Note 1)	mA
FGO Output Current	I _{FGO}	5 ^(Note 1)	mA
Driver Output Current (continuous)	I _{OUT(DC)}	2.0 ^(Note 1)	A/Phase
Driver Output Current (peak) ^(Note2)	I _{OUT(PEAK)}	3.5 ^(Note 1)	A/Phase
Operating Temperature Range	T _{OPR}	-25 to +85	°C
Storage Temperature Range	T _{STG}	-55 to +150	°C
Power Dissipation	Pd	1.00 ^(Note 3)	W
		4.66 ^(Note 4)	W
Junction Temperature	T _{Jmax}	150	°C

(Note 1) Do not exceed Pd, ASO, and T_J=150°C.

(Note 2) Pulse width tw≤1ms, duty=20% pulse.

(Note 3) 74.2mm × 74.2mm × 1.6mm glass epoxy standard board. Reduce by 8.0mW/°C over Ta=25°C.

(Note 4) 4-layer recommended board. Reduce by 37.3mW/°C over Ta=25°C.

Caution: Operating the IC over the absolute maximum ratings may damage the IC. The damage can either be a short circuit between pins or an open circuit between pins and the internal circuitry. Therefore, it is important to consider circuit protection measures, such as adding a fuse, in case the IC is operated over the absolute maximum ratings.

Recommended Operating Conditions (Ta= -25°C to +85°C)

Item	Symbol	Min	Typ	Max	Unit
Supply Voltage	V _{CC}	10	24	28	V

Description of Block(s)

1) Commutation Logic

This IC adopts 120° commutation mode, and the truth table is as follows:

HU	HV	HW	CW (CW=H or Open)			CCW (CW=L)			FGO	
			U	V	W	U	V	W	1FG	3FG
H	L	H	PWM*	H	Hi-z	H	PWM*	Hi-z	L	Hi-z
H	L	L	PWM*	Hi-z	H	H	Hi-z	PWM*	L	L
H	H	L	Hi-z	PWM*	H	Hi-z	H	PWM*	L	Hi-z
L	H	L	H	PWM*	Hi-z	PWM*	H	Hi-z	Hi-z	L
L	H	H	H	Hi-z	PWM*	PWM*	Hi-z	H	Hi-z	Hi-z
L	L	H	Hi-z	H	PWM*	Hi-z	PWM*	H	Hi-z	L

* When PWMB="L", PWM="L", When PWMB="H", PWM="H".

2) Regulator Output Terminal (VREG)

This is constant voltage output terminal of 5V(Typ). It is recommended to connect capacitors of 0.01μF to 1μF. Please be careful that VREG current does not exceed ratings in case of being used for bias power supply of hall elements.

3) Enable Input Terminal (ENB)

Output of each phase can be set to ON/OFF (negative logic) through ENB terminal. When applied voltage is V_{ENA}, the motor is driven (enable). When applied voltage is V_{STBY} or OPEN, the motor stops (stand-by). Stand-by mode has precedence to other control input signal and VREG output is OFF. In addition, ENB terminal is pulled up by internal power supply through a resistance of 100kΩ (Typ) ±30kΩ.

ENB	Operation
H or OPEN	Stand-by
L	Enable

4) PWM Input Terminal (PWMB)

Speed can be controlled by inputting PWM signal into PWMB terminal (negative logic). Synchronous rectifier PWM can be achieved through lower switching. When PWMB="L", driver output that belongs to Hall input logic is "L". When PWMB="H" or open, driver output is "H". When PWMB="H" or OPEN status is detected 104μs (Typ), the synchronous rectifier is OFF. Synchronous rectifier is ON through falling edges of subsequent PWMB. Additionally, PWMB terminal is pulled up by VREG through a resistance of 100kΩ (Typ) ±30kΩ.

PWMB	Driver Output
H or OPEN	H (Hi-z)
L	L

5) Brake Input Terminal (BRKB)

Motor rotation can be quickly stopped by BRKB terminal (negative logic). When BRKB="L", all driver outputs are "L" (short brake). When BRKB="H" or OPEN, then short brake action is released. In addition, BRKB terminal is pulled up by VREG through a resistance of 100kΩ (Typ) ±30kΩ.

BRKB	Operation
H or OPEN	Normal
L	Short brake

6) CW/CCW Input Terminal (CW)

Rotation direction can be switched with CW terminal. When CW="H" or OPEN, the direction is CW. When CW="L", the direction is CCW. Though we do not recommend switching rotation direction when motor is rotating, because if rotation direction is switched when rotating, the rotation speed becomes hall frequency that is up to less than 40Hz (Typ) and it is switched to the set rotation direction after the action short brake. In addition, CW terminal is pulled up by VREG through resistance of 100kΩ (Typ) ±30kΩ.

CW	Direction
H or OPEN	CW
L	CCW

7) 1FG/3FG Switching Terminal (FGSW)

FG signal that is output from FGO terminal can be switched to 1FG/3FG. It becomes 3FG by FGSW="H" or OPEN, and 1 FG by FGSW="L". Moreover, FGSW terminal is pulled up by VREG through resistance of 100kΩ (Typ)±30kΩ.

FGSW	FGO
H or OPEN	3FG
L	1FG

8) Hall Input (HALL: HUP, HUN, HVP, HVN, HWP, HWN)

Hall input amplifier is designed with hysteresis (±15mV (Typ)) in order to prevent incorrect action due to noise inside. So please set bias current for Hall element to make amplitude of Hall input voltage over minimum input voltage ($V_{HALLMIN}$). Here, we recommend you to connect the ceramic capacitor with about 100pF to 0.01μF between difference input terminals of Hall amplifier. The in-phase input voltage range designed for Hall input Amplifier is V_{HALLCM} , 0V to VREG-1.7V, so please set within this range when applying bias to Hall element. When all Hall inputs become "H" or "L", detect circuit detects these Hall input abnormalities and makes all driver outputs "Hi-z".

9) FG Output Terminal (FGO)

1FG or 3FG signal that is reshaped by hall signal is output from FGO terminal. It does not have output in stand-by mode. In addition, because FG terminal is output from open drain, please use resistance of about 10kΩ to 100kΩ pulled up from outside. In that case, please be careful that FGO voltage or current never exceed rating.

10) Power Supply Terminal (VCC)

Please make low impedance thick and short since motor drive current flows. Please stabilize V_{CC} by placing bypass capacitor near terminal as much as possible because V_{CC} might be changed considerably by motor BEMF and PWM switching. Please add capacity of capacitor as necessary when using large current and motor with large BEMF. Moreover, it is recommended to place laminated ceramic capacitor of around 0.01μF to 0.1μF in parallel on the purpose of decreasing impedance of power supply broadband. Please be careful that V_{CC} never exceeds ratings. VCC terminal has clamp element for preventing ESD damage. If applying steep pulse signal and voltage such as surge more than ratings, this clamp element operates, which might be a cause of destruction. It is effective to put zener diode that corresponds to V_{CC} absolute maximum ratings. Diode for preventing ESD damage is inserted between VCC and GND terminals. Please note that IC might be destroyed when BEMF is applied to VCC and GND terminals.

11) Ground Terminal (GND, PGND)

Wiring impedance from this terminal should be as low as possible for reducing noise of switching current and stabilizing basic voltage inside of IC, and the impedance also should be the lowest potential in any operating condition. In addition, please do pattern design not to have same impedance as other GND pattern.

12) Driver Output Terminal (U, V, W)

Impedance wiring should be thick, short, and low due to motor drive current. When using big current, in case that driver current changes considerably toward positive and negative (when BEMF is large), malfunction or destruction of IC might occur. It is effective to add shot key diode. Moreover, clamp element is built in driver output terminal in order to prevent ESD damage. If applying steep pulse signal or voltage such as surge more than ratings, this clamp element operates. Then it might cause destruction of IC, so that please pay attention not to exceed ratings. Additionally, When driver output converts "L"→"H" or "H"→"L", for example when synchronous rectification PWM operating, dead time (1μs to 2μs(Typ)) can be set to prevent simultaneous ON of output top & bottom MOS.

13) Capacitor Connection Terminal for Boosting, Boosting Output Terminal (CP1, CP2, VG)

Charge pump is built-in for upper Nch MOS drive signal of driver output. Boosting voltage of $V_{CC}+5V$ (Typ) occurs in VG terminal by connecting capacitor between CP1 to CP2 terminals and VG to VCC terminals. It is recommended to use capacitor more than 0.1μF.

14) Resistor Connection Terminal for Detecting Output Current (RNF)

Please insert resistor for detecting current 0.05Ω to 0.5Ω between RNF and GND. When deciding resistor value, it should be careful that consumption electricity of resistor for detecting current $I_{OUT}^2 \cdot R[W]$ does not exceed rating of resistor. In addition, please do not have same impedance as other GND patterns by using low impedance wiring, since motor drive current flows into pattern of RNF terminal to resistor for detecting current to GND. In case that RNF voltage goes over rating ($0.7V$), circuit malfunction might occur. Therefore please do not exceed rating. When RNF terminal is shorted to GND, big current flows due to a lack of normal current limit operation. Please be careful that OCP or TSD might operate in that case. Similarly, if RNF terminal is OPEN, output current might not flow, which also becomes a cause of malfunction.

15) Comparator Input Terminal for Detecting Output Current (RCL)

RCL terminal is placed individually as input terminal of current detect comparator in order to avoid deterioration of current detect accuracy by wire impedance inside IC of RNF terminal. Therefore, when operating current limit, please be sure to connect RNF terminal and RCL terminal. Moreover, it is possible to reduce deterioration of current detect accuracy by impedance of board pattern between RNF terminal and resistor for detecting current by connecting wiring from RCL terminal most adjacent to resistor for detecting current. Please design pattern considering wiring that is less influenced by noise. Additionally, when RCL terminal is shorted to GND, big current might flow due to a lack of normal current limit operation. Please be careful that OCP or TSD might operate in that case.

16) Non-connection Terminal (NC)

It is not connected to internal circuit electrically.

17) Control Signal Sequence

Though we recommend you input control signals of ENB, PWMB, BRKB, FGSW, CW, CLNMT, LPE terminals after inputting V_{CC} , there is no problem if you input control signals before inputting V_{CC} . If LPE terminal is set to "H" or "M" when being started, please be informed that if motor rotation cannot be detected within the set time (edge of FGO signal cannot be input), then the MLP circuit starts and motor fails to start. Moreover, the order of priority is set to control signal and IC internal signal. Please refer to the following table.

Priority of Control Signal

Priority	Input / Internal Signals
1 st	ENB, UVLO
2 nd	BRKB $\uparrow\downarrow$, CW $\uparrow\downarrow$, PWMB \downarrow
3 rd	TSD, OCP, MLP, HALLERR
4 th	OVLO
5 th	BRKB
6 th	CL
7 th	PWMB, CW

Note) $\uparrow\downarrow$ means rising and falling edges of signal.
For signal name, please see state transition diagram.

Protection Circuit

1) Current Limit Circuit (CL circuit)

Current limit of output (Current Limit: CL) can be achieved by changing voltage of output current with resistor between RNF and GND, and then inputting the voltage into RCL terminal. In order to avoid error detection of current detection comparator by RNF spike noise that occurs at output ON, using mask time can be efficient. Current detection is invalid during mask time after RCL voltage becomes more than 0.2V (Typ). Then please turn OFF all lower MOS of driver output, which is returned automatically after specified time (32 μ s (Typ)). This operation is not synchronized with PWM signal that is input into PWMB terminal. Moreover, it is possible to change mask time by CLNMT terminal. At CLNMT="H" or OPEN, 0.5 μ s (Typ). At CLNMT="M", 0.75 μ s (Typ). At CLNMT="L", 0.25 μ s (Typ). CLNMT terminal is also pulled up by VREG through a resistance of 100k Ω (Typ) \pm 30k Ω .

CLNMT	Mask time
H or OPEN	0.5 μ s (Typ) \pm 0.3 μ s
M	0.75 μ s (Typ) \pm 0.4 μ s
L	0.25 μ s (Typ) \pm 0.2 μ s

2) Thermal Shut Down Circuit (TSD Circuit)

When chip temperature of driver IC rises and exceeds the set temperature (175 $^{\circ}$ C (Typ)), the thermal shut down circuit (Thermal Shut Down: TSD) begins to work. At this time, the driver outputs all become "Hi-z". In addition, the TSD circuit is designed with hysteresis (25 $^{\circ}$ C (Typ)), therefore, when the chip temperature drops, it returns to normal working condition. Moreover, the purpose of the TSD circuit is to protect driver IC from thermal breakdown, therefore, temperature of this circuit will be over working temperature when it is started up. Thus, thermal design should have sufficient margin, so do not take continuous use and action of the circuit as a precondition.

3) Over Current Protection Circuit (OCP Circuit)

Over current protection (Over Current Protection : OCP) is built-in in order to prevent from destruction when being shorted between output terminals and also being VCC/GND shorted. Therefore output current exceeds ratings and specified current flows. In that case, driver outputs are all latched to Hi-z condition. Latch can be released by going through stand-by condition or switching BRKB/CW logic. However, output current rating is exceeded when this circuit operates. Thus, please design sufficient margin not to take continuous use and action of the circuit as a precondition.

4) Under Voltage Lock Out Circuit (UVLO Circuit)

There is a built-in under voltage lock out circuit (Under Voltage Lock Out: UVLO) used to ensure the lowest power supply voltage for drive IC to work and to prevent error action of IC. When V_{CC} declines to V_{UVL} (6V (Typ)), all of the driver outputs should be "Hi-z". At the same time, UVLO circuit is designed with hysteresis (1V (Typ)), so when V_{CC} reaches more than V_{UVH} (7V (Typ)), it enters normal working condition.

5) Over Voltage Lock Out Circuit (OVLO circuit)

There is built-in over voltage lock out circuit (Over Voltage Lock Out: OVLO) used to restrain rise of V_{CC} when motor is decelerating. When LPE terminal is at "M" and V_{CC} is over V_{OVH1} (16V (Typ)), and when LPE terminal is at "H" or "L" and V_{CC} is over V_{OVH2} (31V (Typ)), a certain time (4ms (Typ)) of short brake action is conducted. What's more, because OVLO circuit is designed with hysteresis, therefore, when V_{OVH1} is below V_{OVL1} (15V (Typ)) and when V_{OVH2} is below V_{OVL2} (30.5V (Typ)), it can return to normal working condition after a certain time of short brake action.

6) Motor Lock Protection Circuit (MLP circuit)

There is built-in motor lock protection circuit (Motor Lock Protection: MLP). The ON/OFF of MLP circuit and OVLO threshold can be set from LPE terminal. In monitoring Hall signals, when the LPE = "H" or "M" and Hall signal logic does not change to 1.1sec(Typ), all driver outputs are locked as "Hi-z". Latch can be released via standby status or through switching BRKB/CW logic. Moreover, when PWMB = "H" or OPEN state is detected for about 15ms, latch can be released by rising and falling edges of subsequent PWMB. However, when LPE = "L", MLP circuit does not work when short brake action (including switching rotation direction) enables or TSD circuit works. In addition, LPE terminal is pulled up by VREG through a resistance of 100k Ω (Typ) \pm 30 k Ω .

LPE	Monitoring Time	OVLO Threshold
H or OPEN	1.1sec(Typ) \pm 30%	V _{OVH2} , V _{OVL2}
M	1.1sec(Typ) \pm 30%	V _{OVH1} , V _{OVL1}
L	Disable	V _{OVH2} , V _{OVL2}

Electrical Characteristics (Unless otherwise specified Ta=25°C, V_{CC}=24V)

Item	Symbol	Limit			Unit	Condition
		Min	Typ	Max		
[Whole]						
Circuit Current	I _{CC}	-	3.9	7.8	mA	V _{ENB} =0V
Stand-by Current	I _{STBY}	-	0.6	1.2	mA	ENB=OPEN
VREG Voltage	V _{REG}	4.5	5.0	5.5	V	I _{VREG} =-10mA
[Driver output]						
Output On Resistance	R _{ON}	-	0.17	0.27	Ω	I _{OUT} =±1.5A(Upper + Lower)
[Hall input]						
Input Bias Current	I _{HALL}	-2.0	-0.1	+2.0	μA	V _{HALL} =0V
Range of In-phase Input Voltage	V _{HALLCM}	0	-	V _{REG} -1.7	V	
Minimum Input Voltage	V _{HALLMIN}	50	-	-	mV _{p-p}	
HYS Level +	V _{HALLHY+}	5	15	25	mV	
HYS Level -	V _{HALLHY-}	-25	-15	-5	mV	
[Input of Control : ENB]						
Input Current	I _{ENB}	-75	-45	-25	μA	V _{ENB} =0V
Standby Voltage	V _{STBY}	2.0	-	V _{REG}	V	
Enable Voltage	V _{ENA}	0	-	0.8	V	
[Input of Control : PWMB, CW, BRKB, FGSW]						
Input Current	I _{IN}	-80	-50	-30	μA	V _{IN} =0V
Voltage Input H	V _{INH}	2.0	-	V _{REG}	V	
Voltage Input L	V _{INL}	0	-	0.8	V	
Minimum Input Pulse Width	t _{PLSMIN}	1	-	-	msec	CW, BRKB
[Input of Control : LPE, CLNMT]						
Input Current	I _{IN2}	-80	-50	-30	μA	V _{IN2} =0V
Input Voltage "H"	V _{INH2}	0.8 × V _{REG}	-	V _{REG}	V	
Input Voltage "M"	V _{INM2}	0.4 × V _{REG}	-	0.6 × V _{REG}	V	
Input Voltage "L"	V _{INL2}	0	-	0.2 × V _{REG}	V	
[FG Output : FGO]						
Output Voltage L	V _{FGOL}	0	0.1	0.3	V	I _{FGO} =2mA
[Current Limit]						
Detect Voltage	V _{CL}	0.18	0.20	0.22	V	
[UVLO]						
Release Voltage	V _{UVH}	6.5	7.0	7.5	V	
Lockout Voltage	V _{UVL}	5.5	6.0	6.5	V	
[OVLO]						
Release Voltage1	V _{OVL1}	14.0	15.0	16.0	V	LPE="M"
Lockout Voltage1	V _{OVH1}	15.0	16.0	17.0	V	LPE="M"
Release Voltage2	V _{OVL2}	29.0	30.5	32.0	V	LPE="H" or "L"
Lockout Voltage2	V _{OVH2}	29.5	31.0	32.5	V	LPE="H" or "L"

Timing Chart

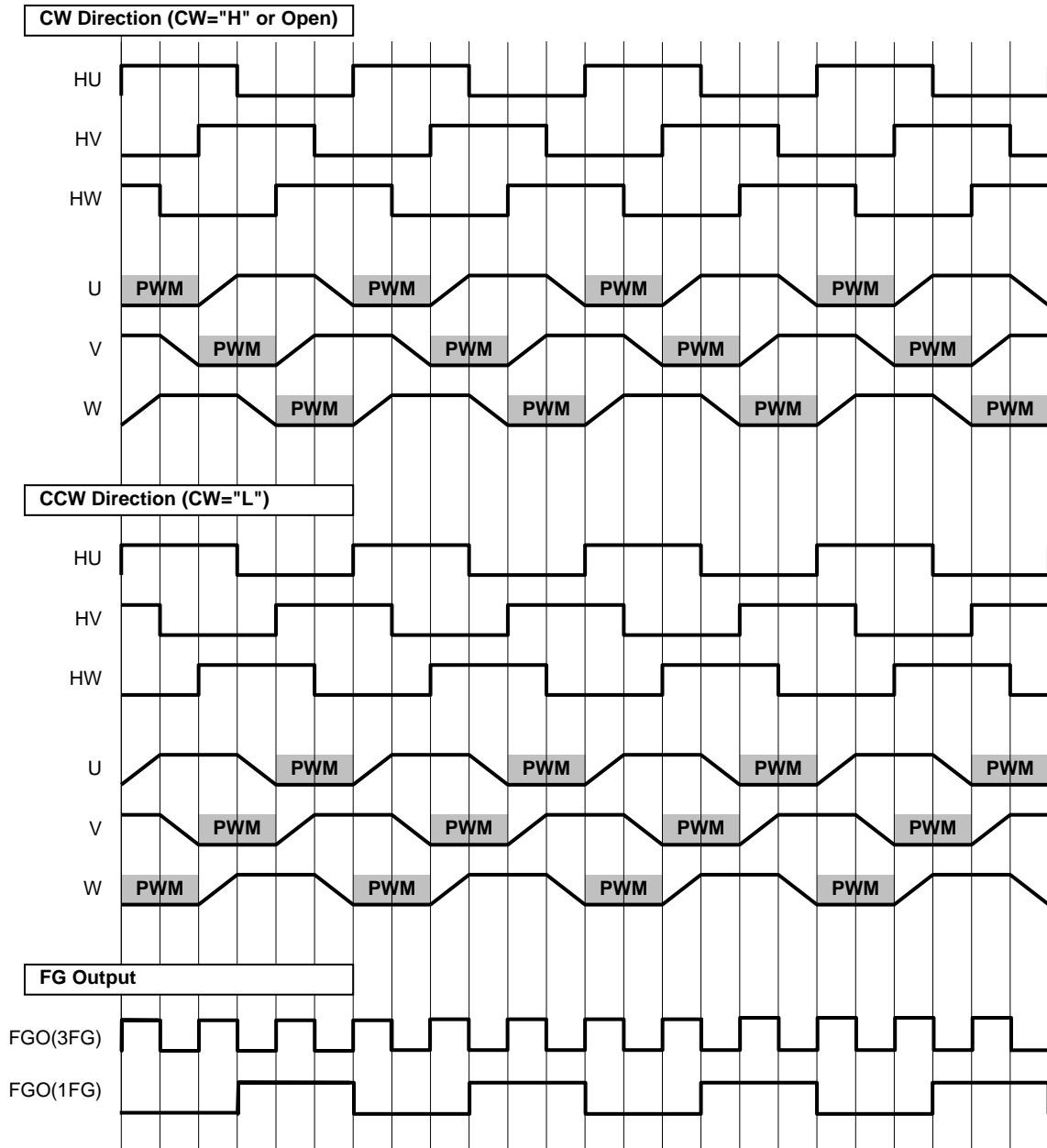

Figure 4. Timing Chart

I/O Equivalence Circuits

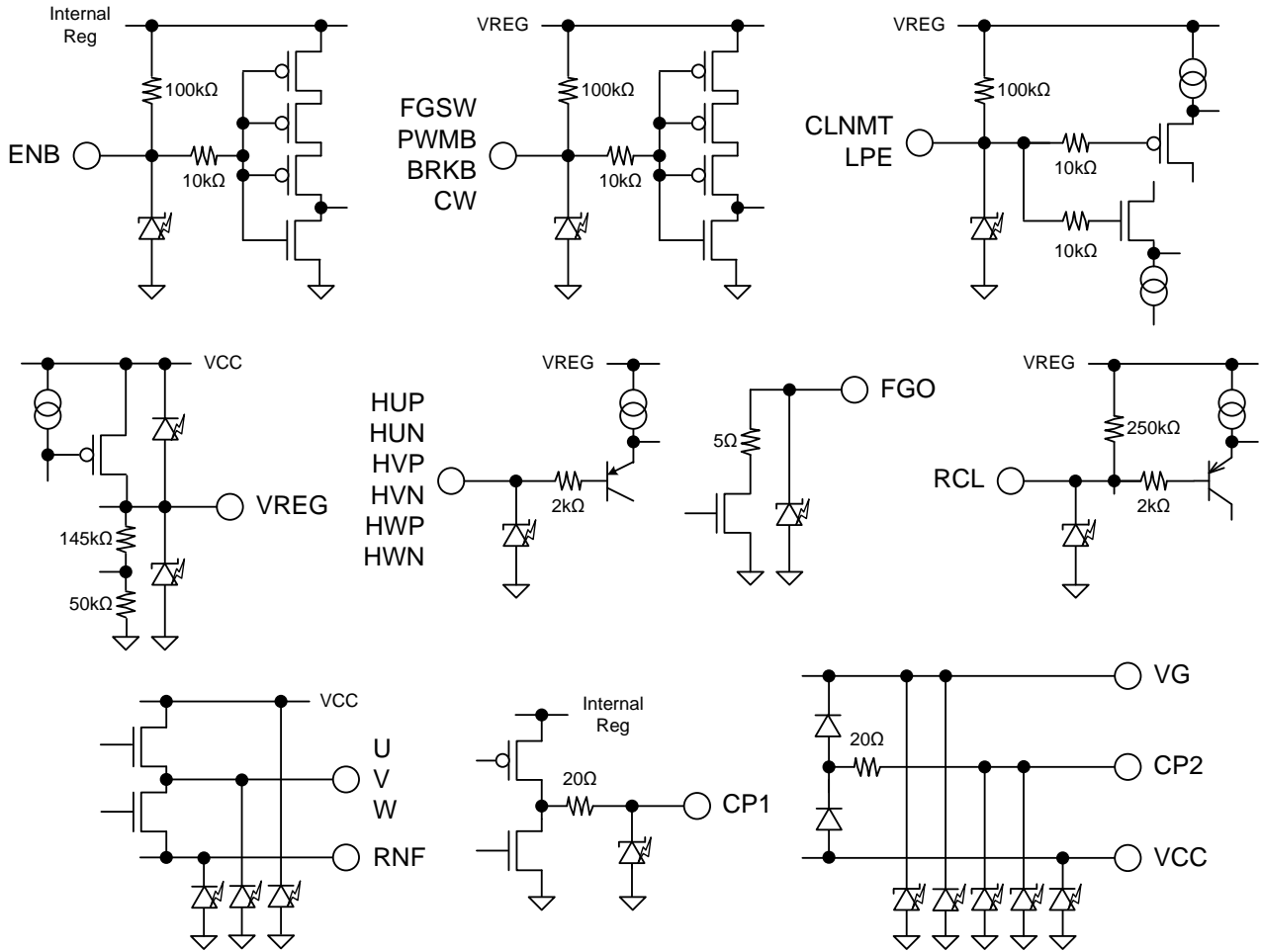

Figure 6. I/O Equivalence Circuits

Power Dissipation

VQFN040V6060 package has metal for heat dissipation on backside of IC. It is supposed to use this metal for processing heat dissipation, so please connect to GND plane on board by soldering and keep GND pattern as large as possible to get enough heat dissipation area. It is impossible to keep power dissipation as shown below without soldering. The Backside metal is shorted to backside of IC chip and it is also GND potential. Therefore please do not make wiring pattern other than GND right under backside metal of IC, since malfunction and destruction of IC might occur by being shorted to potential other than GND.

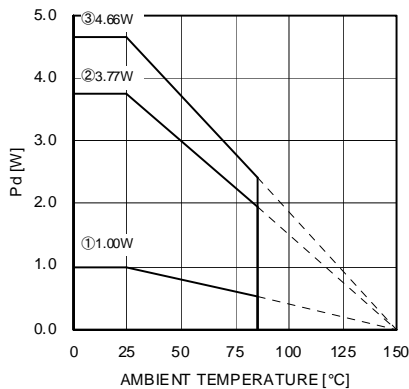

Figure 7. Derating Curve (VQFN040V6060)

Package thermal resistor

Board	θ_{j-a} [°C/W]
Board ①	125
Board ②	33.2
Board ③	26.8

PCB size : 74.2mm × 74.2mm × 1.6mm
 Board① : 1 layer PCB (1 layer : 23.69mm²)
 Board② : 4 layer PCB (1,4 layer : 23.69mm², 2,3 layer : 5505mm²)
 Board③ : 4 layer PCB (all layers : 5505mm²)
 () : Copper foil pattern area size
 Caution : Values about heat reducing curve and packaged thermal resistor are tested values.

Operational Notes

1. Reverse Connection of Power Supply

Connecting the power supply in reverse polarity can damage the IC. Take precautions against reverse polarity when connecting the power supply, such as mounting an external diode between the power supply and the IC's power supply pins.

2. Power Supply Lines

Design the PCB layout pattern to provide low impedance supply lines. Separate the ground and supply lines of the digital and analog blocks to prevent noise in the ground and supply lines of the digital block from affecting the analog block. Furthermore, connect a capacitor to ground at all power supply pins. Consider the effect of temperature and aging on the capacitance value when using electrolytic capacitors.

3. Ground Voltage

Ensure that no pins are at a voltage below that of the ground pin at any time, even during transient condition.

4. Ground Wiring Pattern

When using both small-signal and large-current ground traces, the two ground traces should be routed separately but connected to a single ground at the reference point of the application board to avoid fluctuations in the small-signal ground caused by large currents. Also ensure that the ground traces of external components do not cause variations on the ground voltage. The ground lines must be as short and thick as possible to reduce line impedance.

5. Thermal Consideration

Should by any chance the power dissipation rating be exceeded the rise in temperature of the chip may result in deterioration of the properties of the chip. The absolute maximum rating of the Pd stated in this specification is when the IC is mounted on a 74.2mm x 74.2mm x 1.6mm glass epoxy board. In case of exceeding this absolute maximum rating, increase the board size and copper area to prevent exceeding the Pd rating.

6. Recommended Operating Conditions

These conditions represent a range within which the expected characteristics of the IC can be approximately obtained. The electrical characteristics are guaranteed under the conditions of each parameter.

7. Inrush Current

When power is first supplied to the IC, it is possible that the internal logic may be unstable and inrush current may flow instantaneously due to the internal powering sequence and delays, especially if the IC has more than one power supply. Therefore, give special consideration to power coupling capacitance, power wiring, width of ground wiring, and routing of connections.

8. Operation Under Strong Electromagnetic Field

Operating the IC in the presence of a strong electromagnetic field may cause the IC to malfunction.

9. Testing on Application Boards

When testing the IC on an application board, connecting a capacitor directly to a low-impedance output pin may subject the IC to stress. Always discharge capacitors completely after each process or step. The IC's power supply should always be turned off completely before connecting or removing it from the test setup during the inspection process. To prevent damage from static discharge, ground the IC during assembly and use similar precautions during transport and storage.

10. Inter-pin Short and Mounting Errors

Ensure that the direction and position are correct when mounting the IC on the PCB. Incorrect mounting may result in damaging the IC. Avoid nearby pins being shorted to each other especially to ground, power supply and output pin. Inter-pin shorts could be due to many reasons such as metal particles, water droplets (in very humid environment) and unintentional solder bridge deposited in between pins during assembly to name a few.

Operational Notes – continued

11. Unused Input Terminals

Input pins of an IC are often connected to the gate of a MOS transistor. The gate has extremely high impedance and extremely low capacitance. If left unconnected, the electric field from the outside can easily charge it. The small charge acquired in this way is enough to produce a significant effect on the conduction through the transistor and cause unexpected operation of the IC. So unless otherwise specified, unused input pins should be connected to the power supply or ground line.

12. Regarding the Input Pins of the IC

This monolithic IC contains P+ isolation and P substrate layers between adjacent elements in order to keep them isolated. P-N junctions are formed at the intersection of the P layers with the N layers of other elements, creating a parasitic diode or transistor. For example (refer to figure below):

When $GND > Pin A$ and $GND > Pin B$, the P-N junction operates as a parasitic diode.
When $GND > Pin B$, the P-N junction operates as a parasitic transistor.

Parasitic diodes inevitably occur in the structure of the IC. The operation of parasitic diodes can result in mutual interference among circuits, operational faults, or physical damage. Therefore, conditions that cause these diodes to operate, such as applying a voltage lower than the GND voltage to an input pin (and thus to the P substrate) should be avoided.

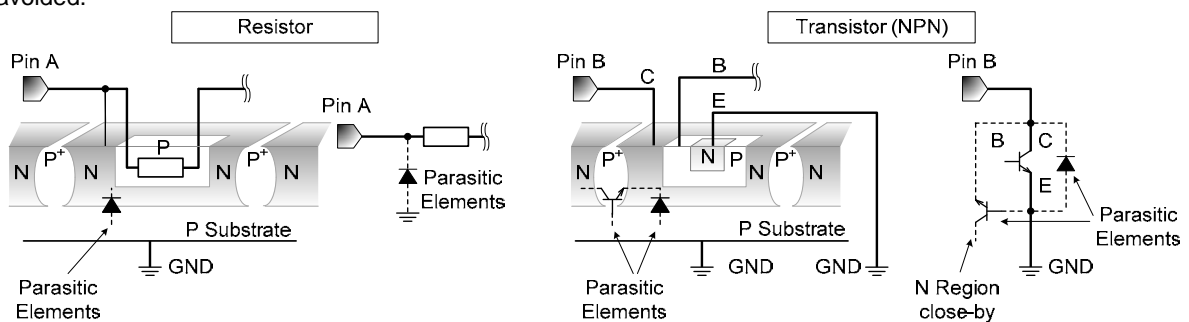

Figure 9. Example of monolithic IC structure

13. Ceramic Capacitor

When using a ceramic capacitor, determine the dielectric constant considering the change of capacitance with temperature and the decrease in nominal capacitance due to DC bias and others.

14. Area of Safe Operation (ASO)

Operate the IC such that the output voltage, output current, and power dissipation are all within the Area of Safe Operation (ASO).

15. Thermal Shutdown Circuit (TSD)

This IC has a built-in thermal shutdown circuit that prevents heat damage to the IC. Normal operation should always be within the IC's power dissipation rating. If however the rating is exceeded for a continued period, the junction temperature (T_j) will rise which will activate the TSD circuit that will turn OFF all output pins. When the T_j falls below the TSD threshold, the circuits are automatically restored to normal operation.

Note that the TSD circuit operates in a situation that exceeds the absolute maximum ratings and therefore, under no circumstances, should the TSD circuit be used in a set design or for any purpose other than protecting the IC from heat damage.

16. Over Current Protection Circuit (OCP)

This IC has a built-in overcurrent protection circuit that activates when the output is accidentally shorted. However, it is strongly advised not to subject the IC to prolonged shorting of the output.

Ordering Information

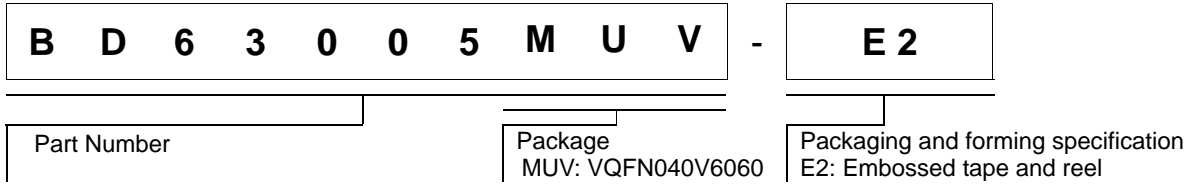

Marking Diagrams

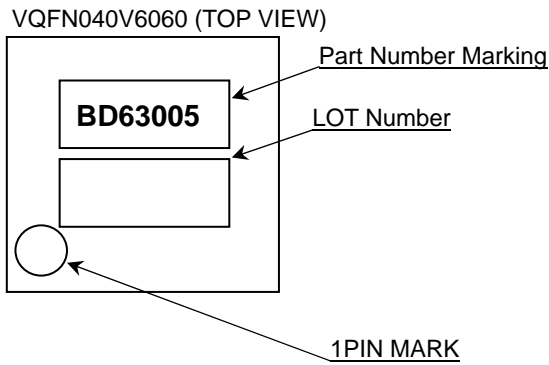

Part Number Marking	Package	Orderable Part Number
BD63005	VQFN040V6060	BD63005MUV-E2

Physical Dimension, Tape and Reel Information

Package Name	VQFN040V6060
--------------	--------------

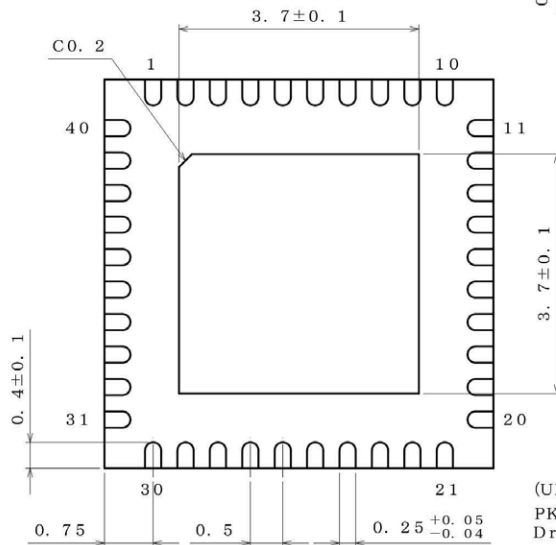
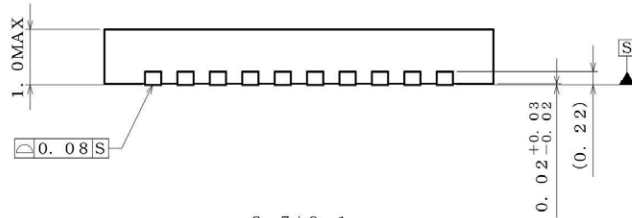
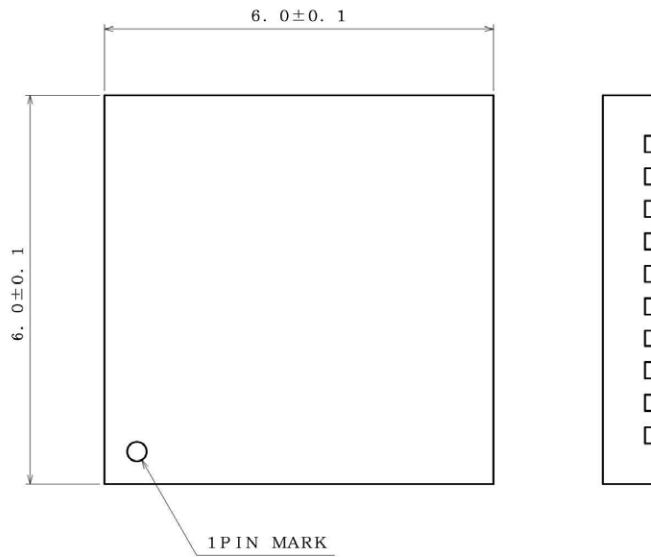

(UNIT : mm)
 PKG : VQFN040V6060
 Drawing No. EX464-5001-1

<Tape and Reel information>

Tape	Embossed carrier tape
Quantity	2000pcs
Direction of feed	E2 (The direction is the 1pin of product is at the upper left when you hold reel on the left hand and you pull out the tape on the right hand)

*Order quantity needs to be multiple of the minimum quantity.

Notice

Precaution on using ROHM Products

- Our Products are designed and manufactured for application in ordinary electronic equipments (such as AV equipment, OA equipment, telecommunication equipment, home electronic appliances, amusement equipment, etc.). If you intend to use our Products in devices requiring extremely high reliability (such as medical equipment ^(Note 1), transport equipment, traffic equipment, aircraft/spacecraft, nuclear power controllers, fuel controllers, car equipment including car accessories, safety devices, etc.) and whose malfunction or failure may cause loss of human life, bodily injury or serious damage to property ("Specific Applications"), please consult with the ROHM sales representative in advance. Unless otherwise agreed in writing by ROHM in advance, ROHM shall not be in any way responsible or liable for any damages, expenses or losses incurred by you or third parties arising from the use of any ROHM's Products for Specific Applications.

(Note1) Medical Equipment Classification of the Specific Applications

JAPAN	USA	EU	CHINA
CLASS III	CLASS III	CLASS II b	CLASS III
CLASS IV		CLASS III	

- ROHM designs and manufactures its Products subject to strict quality control system. However, semiconductor products can fail or malfunction at a certain rate. Please be sure to implement, at your own responsibilities, adequate safety measures including but not limited to fail-safe design against the physical injury, damage to any property, which a failure or malfunction of our Products may cause. The following are examples of safety measures:
 - Installation of protection circuits or other protective devices to improve system safety
 - Installation of redundant circuits to reduce the impact of single or multiple circuit failure
- Our Products are designed and manufactured for use under standard conditions and not under any special or extraordinary environments or conditions, as exemplified below. Accordingly, ROHM shall not be in any way responsible or liable for any damages, expenses or losses arising from the use of any ROHM's Products under any special or extraordinary environments or conditions. If you intend to use our Products under any special or extraordinary environments or conditions (as exemplified below), your independent verification and confirmation of product performance, reliability, etc. prior to use, must be necessary:
 - Use of our Products in any types of liquid, including water, oils, chemicals, and organic solvents
 - Use of our Products outdoors or in places where the Products are exposed to direct sunlight or dust
 - Use of our Products in places where the Products are exposed to sea wind or corrosive gases, including Cl₂, H₂S, NH₃, SO₂, and NO₂
 - Use of our Products in places where the Products are exposed to static electricity or electromagnetic waves
 - Use of our Products in proximity to heat-producing components, plastic cords, or other flammable items
 - Sealing or coating our Products with resin or other coating materials
 - Use of our Products without cleaning residue of flux (even if you use no-clean type fluxes, cleaning residue of flux is recommended); or Washing our Products by using water or water-soluble cleaning agents for cleaning residue after soldering
 - Use of the Products in places subject to dew condensation
- The Products are not subject to radiation-proof design.
- Please verify and confirm characteristics of the final or mounted products in using the Products.
- In particular, if a transient load (a large amount of load applied in a short period of time, such as pulse. is applied, confirmation of performance characteristics after on-board mounting is strongly recommended. Avoid applying power exceeding normal rated power; exceeding the power rating under steady-state loading condition may negatively affect product performance and reliability.
- De-rate Power Dissipation (Pd) depending on Ambient temperature (Ta). When used in sealed area, confirm the actual ambient temperature.
- Confirm that operation temperature is within the specified range described in the product specification.
- ROHM shall not be in any way responsible or liable for failure induced under deviant condition from what is defined in this document.

Precaution for Mounting / Circuit board design

- When a highly active halogenous (chlorine, bromine, etc.) flux is used, the residue of flux may negatively affect product performance and reliability.
- In principle, the reflow soldering method must be used; if flow soldering method is preferred, please consult with the ROHM representative in advance.

For details, please refer to ROHM Mounting specification

Precautions Regarding Application Examples and External Circuits

1. If change is made to the constant of an external circuit, please allow a sufficient margin considering variations of the characteristics of the Products and external components, including transient characteristics, as well as static characteristics.
2. You agree that application notes, reference designs, and associated data and information contained in this document are presented only as guidance for Products use. Therefore, in case you use such information, you are solely responsible for it and you must exercise your own independent verification and judgment in the use of such information contained in this document. ROHM shall not be in any way responsible or liable for any damages, expenses or losses incurred by you or third parties arising from the use of such information.

Precaution for Electrostatic

This Product is electrostatic sensitive product, which may be damaged due to electrostatic discharge. Please take proper caution in your manufacturing process and storage so that voltage exceeding the Products maximum rating will not be applied to Products. Please take special care under dry condition (e.g. Grounding of human body / equipment / solder iron, isolation from charged objects, setting of Ionizer, friction prevention and temperature / humidity control).

Precaution for Storage / Transportation

1. Product performance and soldered connections may deteriorate if the Products are stored in the places where:
 - [a] the Products are exposed to sea winds or corrosive gases, including Cl₂, H₂S, NH₃, SO₂, and NO₂
 - [b] the temperature or humidity exceeds those recommended by ROHM
 - [c] the Products are exposed to direct sunshine or condensation
 - [d] the Products are exposed to high Electrostatic
2. Even under ROHM recommended storage condition, solderability of products out of recommended storage time period may be degraded. It is strongly recommended to confirm solderability before using Products of which storage time is exceeding the recommended storage time period.
3. Store / transport cartons in the correct direction, which is indicated on a carton with a symbol. Otherwise bent leads may occur due to excessive stress applied when dropping of a carton.
4. Use Products within the specified time after opening a humidity barrier bag. Baking is required before using Products of which storage time is exceeding the recommended storage time period.

Precaution for Product Label

QR code printed on ROHM Products label is for ROHM's internal use only.

Precaution for Disposition

When disposing Products please dispose them properly using an authorized industry waste company.

Precaution for Foreign Exchange and Foreign Trade act

Since our Products might fall under controlled goods prescribed by the applicable foreign exchange and foreign trade act, please consult with ROHM representative in case of export.

Precaution Regarding Intellectual Property Rights

1. All information and data including but not limited to application example contained in this document is for reference only. ROHM does not warrant that foregoing information or data will not infringe any intellectual property rights or any other rights of any third party regarding such information or data. ROHM shall not be in any way responsible or liable for infringement of any intellectual property rights or other damages arising from use of such information or data.:
2. No license, expressly or implied, is granted hereby under any intellectual property rights or other rights of ROHM or any third parties with respect to the information contained in this document.

Other Precaution

1. This document may not be reprinted or reproduced, in whole or in part, without prior written consent of ROHM.
2. The Products may not be disassembled, converted, modified, reproduced or otherwise changed without prior written consent of ROHM.
3. In no event shall you use in any way whatsoever the Products and the related technical information contained in the Products or this document for any military purposes, including but not limited to, the development of mass-destruction weapons.
4. The proper names of companies or products described in this document are trademarks or registered trademarks of ROHM, its affiliated companies or third parties.

General Precaution

1. Before you use our Products, you are requested to carefully read this document and fully understand its contents. ROHM shall not be in any way responsible or liable for failure, malfunction or accident arising from the use of any ROHM's Products against warning, caution or note contained in this document.
2. All information contained in this document is current as of the issuing date and subject to change without any prior notice. Before purchasing or using ROHM's Products, please confirm the latest information with a ROHM sales representative.
3. The information contained in this document is provided on an "as is" basis and ROHM does not warrant that all information contained in this document is accurate and/or error-free. ROHM shall not be in any way responsible or liable for any damages, expenses or losses incurred by you or third parties resulting from inaccuracy or errors of or concerning such information.