

# High Precision Plate Resistors

The LM type resistors are super high precision plate resistors with a simple structure. Small temperature coefficient, excellent moisture resistance, excellent long-term stability and useful as a high voltage load.

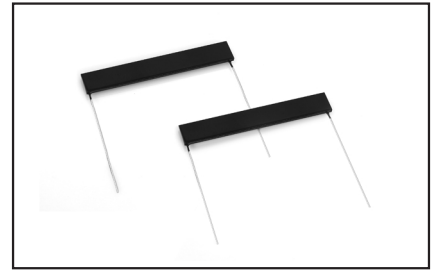

## GENERAL SPECIFICATIONS

Model	Rated Power [W]	Maximum Working Voltage DC [kV]	Voltage Coefficient [ppm/V]	Resistance Range[MΩ]			Resistance Tolerance [%]
				B [±25ppm/°C]	C [±50ppm/°C]	D [±100ppm/°C]	
LM3	0.15	0.5	<30	0.5 ~ 10	0.5 ~ 10	0.5 ~ 1000	* ≤100MΩ
LM5	0.25	0.5	<20	0.5 ~10	0.5 ~ 10	0.5 ~ 1000	B[±0.1], C[±0.25], D[±0.5]
LM10	0.5	1.0	<5	5 ~ 100	5 ~ 100	1 ~ 1000	* ≤1GΩ
LM15	0.75	1.5	<2	5 ~ 100	5 ~ 100	1 ~ 1000	F[±1], G[±2], J[±5], K[±10]
LM20	1.0	2.0	<1	5 ~ 100	5 ~ 100	1 ~ 1000	

\*The voltage coefficient are measured at rated voltage and 1/10 rated voltage.

## CHARACTERISTICS

Values in [ ] mean change in Ω after test

Operation Temperature Range		-55°C ~ +150°C
Temperature Coefficient [ppm/°C]	*A [±10] / B [±25] / C [±50] / D [±100]	Measured at 25°C and 75°C
Long-Term Stability	±[0,1%+0.05Ω]	At normal temperature and humidity for 1000hours
Moisture Resistance	±[0,1%+0.05Ω]	40°C, 90~95% RH, 1000hours
Heat Cycle	±[0,1%+0.05Ω]	-55°C~+150°C, 5cycles
Resistance to Soldering Heat	±[0,1%+0.05Ω]	260±5°C, 10seconds

\*Also consult your local dealer for the availability of resistors with a temperature coefficient of 'A' characteristic (±10ppm/°C)

## DERATING CURVE

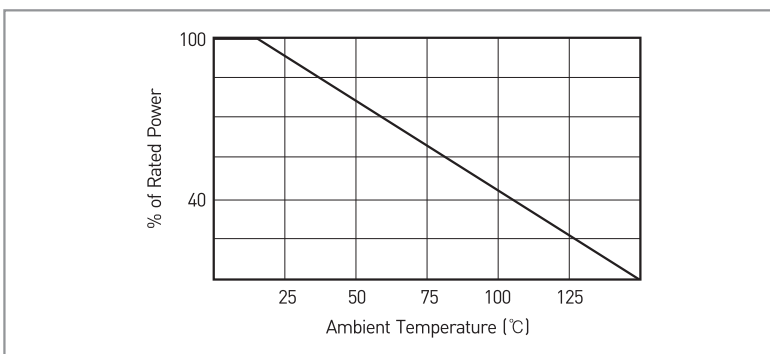

## SHAPE

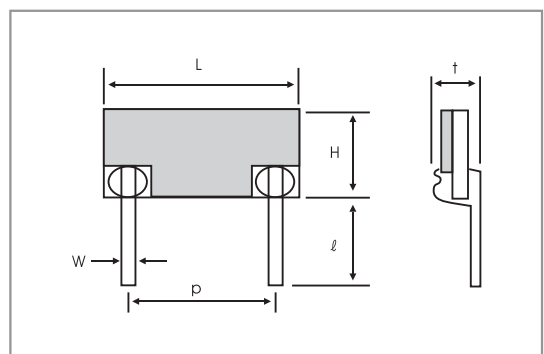

## DIMENSIONS [mm]

Model	L	H	t	P	l	W
LM3	6.3±0.4	2±0.4	1.7±0.5	5.08±0.3	7.5±0.4	0.5±0.1
LM5	6.3±0.4	3.1±0.4				
LM10	12.7±0.4	5±0.4	1.8±0.5	10.16±0.3		
LM15	17.8±0.4			15.24±0.3		
LM20	25.4±0.4			22.86±0.3		