



DUAL BAND(PCS+AMPS) PORTABLE TELEPHONE SCH-8500

SERVICE *Manual*

DUAL MODE TELEPHONE



CONTENTS

1. Specification
2. Nam Programming
3. Test Commands & Test Procedure List
4. Test Procedure
5. Exploded View & its Parts List
6. Electrical Parts List
7. Block Diagram
8. PCB Diagram
9. Schematic Diagrams



1. Specification

1-1 General

ITEM	CDMA	AMPS
Tx Freq. range	1850 ~ 1910MHz	824 ~ 849MHz
Rx Freq. range	1930 ~ 1990MHz	869 ~ 894MHz
Channel Bandwidth	1.23MHz	30KHz
Channel Spacing	50KHz	30KHz
Number of Channel	1200	832
Duplex Separation	80MHz	45MHz
Type of Emission	1M25F9W	40K0F8W,40K0F1D
In/Output Impedance	50	50
Tx Intermediate Freq.	130.38MHz	130.38MHz
Rx Intermediate Freq.	210.38MHz	85.38MHz
Tx Local Freq.	1st (FTX-130.38MHz) 2nd (260.76MHz)	1st (FTX+130.38MHz) 2nd (260.76MHz)
Rx Local Freq	1st (420.76MHz) 2nd (FRX-210.38MHz)	1st (170.76MHz) 2nd (FRX+85.38MHz)
TCXO freq.	19.68MHz	19.68MHz
Freq. Stability	(FRX-80MHz)±150Hz	±2.5ppm
Operating Temperature	-30°C ~ +60°C	-30°C ~ +60°C
Supply Voltage	3.6V	
Size and Weight	Slim : 88mm X 50mm X 23.5mm, 105 g, 500 mA STD : 88mm X 50mm X 25.7mm, 135 g, 1000 mA EXT : 88mm X 50mm X 27.5mm, 151 g, 1600 mA	

1-2. 1.9GHz CDMA(US PCS)

1) General

Frequency Range

- Transmitter : 1850-1910MHz
- Receiver : 1930-1990MHz

Channel Bandwidth : 1.23MHz

Channel Spacing : 50kHz

Number of Channels : 1200

Duplex Separation : 80 MHz

Type of Emission : 1M25F9W

Input/Output Impedance : 50

Intermediate Frequency

- Transmitter : 130.38MHz
- Receiver : 210.38MHz

Local Frequency

- Transmitter : 1st(FTX-130.38), 2nd(260.76MHz),
- Receiver : 1st(FRX-210.38MHz), 2nd(420.76MHz),

TCXO Frequency : 19.68MHz

Frequency Stability : (FRX-80MHz) ± 150 Hz

Operation Temperature : -30°C ~ 60°C

Supply Voltage : +3.6V

2) Transmitter

Waveform Quality : 0.944 or more

Open Loop Power Control Range

- -25dBm : -60.5dBm ~ -41.5dBm
- -65dBm : -20.5dBm ~ +1.5dBm
- -104dBm : +15.0dBm ~ +30dBm

Minimum Tx Power Control : below -50dBm

Closed Loop Power Control Range : ± 24 dB

Maximum RF Output Power : 200mW(+23dBm)

Occupied Bandwidth : 1.23MHz

Conducted Spurious Emission @1.25 MHz: -42dBc/30kHz

3) Receiver

Rx Sensitivity and Dynamic Range : -104dBm, FER = 0.5% or less
: - 25dBm, FER = 0.5% or less

Conducted Spurious Emission

- 1930 ~ 1990MHz : <-81dBm
- 1850 ~ 1910MHz : <-61dBm
- All Other Frequencies : <-47dBm

Single Tone Desensitization : lower than 1 %

Rx power = -101dBm

Tone power = -30dBm

Tone offset from carrier = ± 1.25 MHz

Intermodulation Spurious Response Attenuation : lower than 1 %

Rx power = -101dBm

Tone 1 power = -43dBm

Tone 2 power = -43dBm

Tone 1 : offset from carrier = ± 1.25 MHz

Tone 2 : offset from carrier = ± 2.05 MHz

1-3. 800MHz AMPS

1) General

Frequency Range

- Transmitter : 824~849 MHz
- Receiver : 869~894MHz

Channel Spacing : 30kHz

Number of Channels : 832

Duplex Spacing : 45MHz

Frequency Stability : ± 2.5 ppm($-30^{\circ}\text{C} \sim 60^{\circ}\text{C}$, $-22^{\circ}\text{F} \sim 140^{\circ}\text{F}$)

Modulation/Demodulation

- Voice : PM
- Data : FM

Operating Temperature : $-30^{\circ}\text{C} \sim 60^{\circ}\text{C}$, $-22^{\circ}\text{F} \sim 140^{\circ}\text{F}$

Supply Voltage : 3.6V

2) Transmitter

RF output power : 0.6W(+2/-4dB)

Carrier ON/OFF conditions

“ON” Condition : within ± 3 dB of specification output(in 2 ms)

“OFF” Condition : below -60dBm(in 2ms)

Compressor

Compression Rate : 2 : 1

Attack Time : 3ms

Recovery Time : 13.5ms

Reference Input : input power level for producing a nominal ± 2.9 kHz
: peak frequency deviation of transmitted carrier

Preamphasis : 6dB/OCT within 0.3 ~ 3 kHz

Maximum Frequency Deviation

F3 of G3 : ± 12 kHz

Supervisory Audio Tone : ± 2 kHz($\pm 10\%$)

Signaling Tone : ± 8 kHz($\pm 10\%$)

Wideband Data : ± 8 kHz($\pm 10\%$)

Post Deviation Limiter Filter

3.0 ~ 5.9 kHz : above 40 LOG(F/3000)dB

5.9 ~ 6.1 kHz : above 35dB

6.1 ~ 15 kHz : above 40 LOG(F/3000)dB

Over 15 kHz : above 28 dB

Spectrum Noise Suppression

For all modulation

fo +20 kHz ~ fo + 45 kHz : above 26dB

For modulation by voice and SAT

fo + 45 kHz : above 63dB+10LOG(PY)dB

For modulation by WBD(without SAT) and ST(with SAT)

fo +45 kHz ~ fo + 60 kHz : above 45 dB

fo +60 kHz ~ fo + 90 kHz : above 65 dB

fo +90 kHz ~ 2 fo : above 63 dB + 10 LOG(PY) dB

(where fo = carrier frequency

PY = mean output power in watts)

Harmonic and conducted Spurious Emissions : below 43 + 10 LOG(PY) dB

3) Receiver

De-emphasis : -6dB/OCT within 0.3 ~ 3 kHz

Expander

Expander Rate : 1 : 2

Attack time : within 3 ms

Recovery Time : within 13.5 ms

Reference input : output power level to a 1000Hz tone from a carrier within ± 2.9 kHz
peak frequency deviation

Sensitivity : 12 dB SINAD/-116dBm

Intermodulation Spurious Response Attenuation : above 65dB

RSSI Range : above 60dB

Protection Against Spurious Response Interference : above 60dB

In Band Conducted Spurious Emission

Transmit Band : below -60 dBm

Receive Band : below -80 dBm

Out of Band Conducted Spurious Emissions : below -47dBm

Radiated Spurious Emission

Frequency Range : Maximum Allowable EIRP

25 ~ 70MHz : -45dBm

70 ~ 130MHz : -41dBm

130 ~ 174 MHz : -41 ~ -32dBm

174 ~ 260 MHz : -32 dBm

260 ~ 470 MHz : -32 ~ -26 dBm

470 ~ 1G MHz : -21 dBm

2. Nam Programming

LCD Display	Key in	Function
	MENU, 8,2,0	- Selects NAM programming
Enter Lock ??????	222222	- Enter random 6-digit code(MSL)
SVC Menu 1: Phone # 2: General 3: NAM	1	- Choose 'Phone #'
Phone # 1234567890	keypad OK	- Phone number setup - To change phone number, enter phone #. - Store it.
Mobile ID # 1234567890	keypad OK	- Mobile ID setup - To change phone number, enter phone #. - Store it.
SVC Menu 1: Phone # 2: General 3: NAM	2	- Choose 'GENERAL'
ESN B0000000	OK	- Electronic Serial Number of the phone is displayed
CAI version 10	K	- Common Air Interface version is displayed
SCM 00001010	OK	- Station Class Mark displays the power class, transmission, slotted class, dual mode.
Lock Code 0000	4-digit code OK	Lock code, current status is displayed - to change, enter new code. - stores it
Slot Mode No	* or # OK	Slot mode. 'Yes' indicates the slot mode. - changes the status. - stores it.
Slot Index	20-7 OK	Slot mode index. The higher,the longer sleeping time - to change,enter new one. - stores it.

LCD Display	Key in	Function
Svc Menu 1: Phone # 2: General 3: NAM	3	- Choose 'Setup NAM'
IMSI_MCC 310	number OK	IMSI Mobile Country Code,current code is displayed. - To change,enter new one. - Stores it.
IMSI_MNC 00	number OK	IMSI Mobile Network Code,current code is displayed. - To change,enter new one. - Stores it.
CDMA ACCOLC 0	class number OK	CDMA Access Overload Class,current status is displayed. - To change,enter new one. - Stores it.
CDMA Home SID Yes	* or # OK	CDMA Home system ID,current status is displayed - Changes the status. - Stores it.
CDMA fSID Yes	* or # OK	CDMA foreign SID,current status is displayed. - Changes the system. - Stores it.
CDMA fNID Yes	* or # OK	CDMA foreign NID,current status is displayed. - Changes the system. - Stores it.
HOME SID 1700	number OK	SID written in the list,current status is displayed. - To change,enter new one. - Stores it.
NID 1	number OK	NID written in the list,current status is displayed. - To change,enter new one. - Stores it.
AMPS ACCOLC 0	class number OK	AMPS Access Overload Class,current status is displayed. - To change,enter new one. - Stores it.

LCD Display	Key in	Function
NAM program 1. General 2. Setup NAM1 3. Setup NAM2	3	choose 'Setup NAM2'
NAM2 Digital IMSI_MCC 000	number OK	IMSI Mobile Country Code, current code is displayed. - To change, enter new one. - Store it.
NAM2 Digital IMSI_MNC 00	number OK	IMSI Mobile Network Code, current code is displayed. - To change, enter new one. - Store it.
NAM2 Digital Phone # 1234567890	Phone number OK	- Phone number - To change, enter new one. - Store it.
NAM2 Digital Directory # 1234567890	Phone number OK	- Directory number - To change, enter new one. - Store it.
NAM2 Digital Home SID 01 1	Phone number OK	1st CDMA Home system ID, current status is displayed - To change, enter new one. - Store it.
NAM2 Digital Home NID 01 65535	Phone number OK	1st CDMA Home Network ID, current status is displayed - To change, enter new one. - Store it.
NAM2 Digital Home SID 02 1	Phone number OK	2nd CDMA Home system ID, current status is displayed - To change, enter new one. - Store it.
NAM2 Digital Home NID 02 65535	Phone number OK	2nd CDMA Home Network ID, current status is displayed - To change, enter new one. - Store it.
————— repeated to SID 20 & NID 20 —————		
NAM2 Digital Lockout SID01 0	ID number OK	1st lock system ID,current status is displayed. - To change, enter new one. - Store it.

LCD Display	Key in	Function
NAM2 Digital Lockout SID02 0	ID number OK	2nd lock system ID,current status is displayed. - To change, enter new one. - Store it.
----- repeated to Lockout SID10 -----		
NAM2 Digital CDMA Home SID Yes	< or > OK	CDMA Home system ID, current status is displayed - Changes the status. - Store it.
NAM2 Digital CDMA fSID Yes	< or > OK	CDMA foreign SID, current status is displayed. - Changes the system. - Store it.
NAM2 Digital CDMA fNID Yes	< or > OK	CDMA foreign NID, current status is displayed. - Changes the system. - Store it.
NAM2 Digital CDMA ACCOLC 6	class number OK	CDMA Access Overload Class, current status is displayed. - To change, enter new one. - Store it.
NAM2 Analog Phone # 1234567890	Phone number OK	-Phone number - To change, enter new one. - Store it.
NAM2 Analog Directory # 1234567890	Phone number OK	- Directory number - To change, enter new one. - Store it.
NAM2 Analog Home SID 1	Phone number OK	Analog Home system ID, current status is displayed - To change, enter new one. - Store it.
NAM2 Analog Auto Reg Yes	< or > OK	Auto Registration, current status is displayed - Changes the status. - Store it.
NAM2 Analog ACCOLC 6	class number OK	Analog Access Overload Class, current status is displayed. - To change, enter new one. - Store it

4. Test Procedure

4-1 List of Equipment

- DC Power Supply
- Test Jig
- Test Cable
- CDMA Mobile Station Test Set HP8924C, HP83236A, CMD-80, etc
- Spectrum Analyzer(include CDMA Test Mode) HP8596E

4-2 Configuration of Test

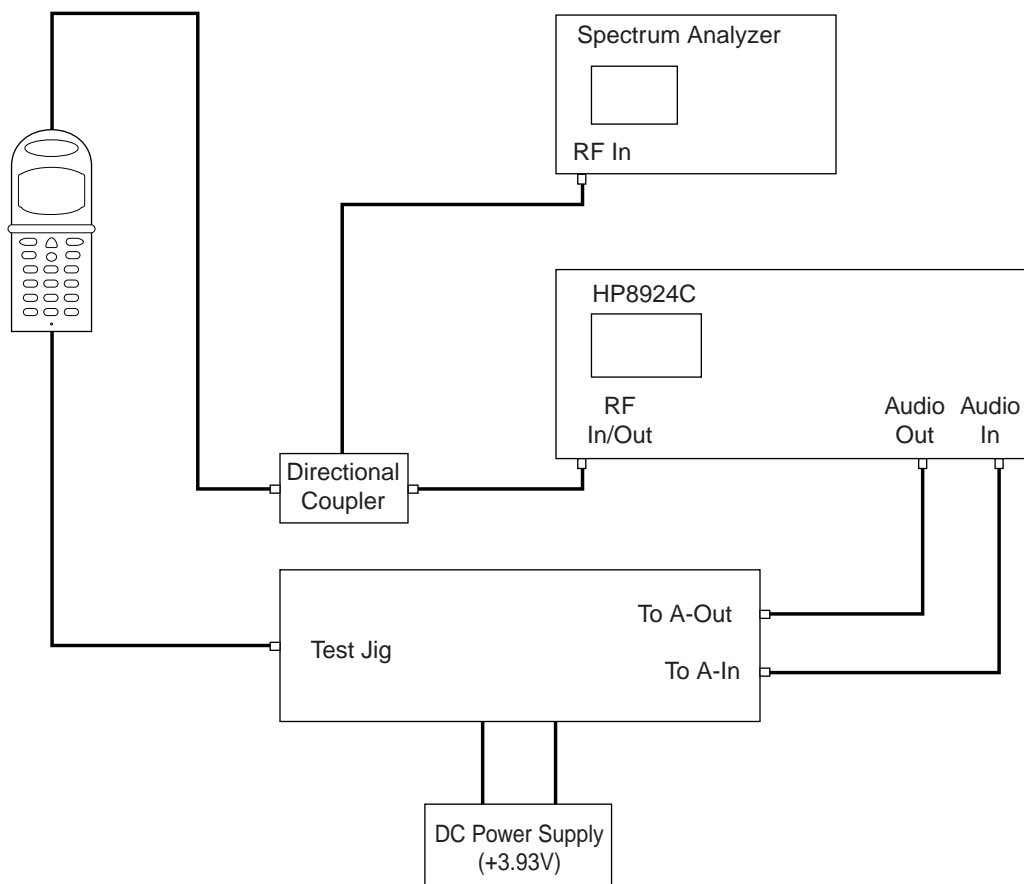

✱ CAUTION : The test jig and data cable has a voltage drop of 0.33V at FM Max power output, you'd better set the DC power supply to 3.93V for normal test condition. (Nominal voltage of battery is 3.6V at cellular phone)

4-3 TEST CABLE DESCRIPTION FOR SCH-8500

1. TEST CABLE

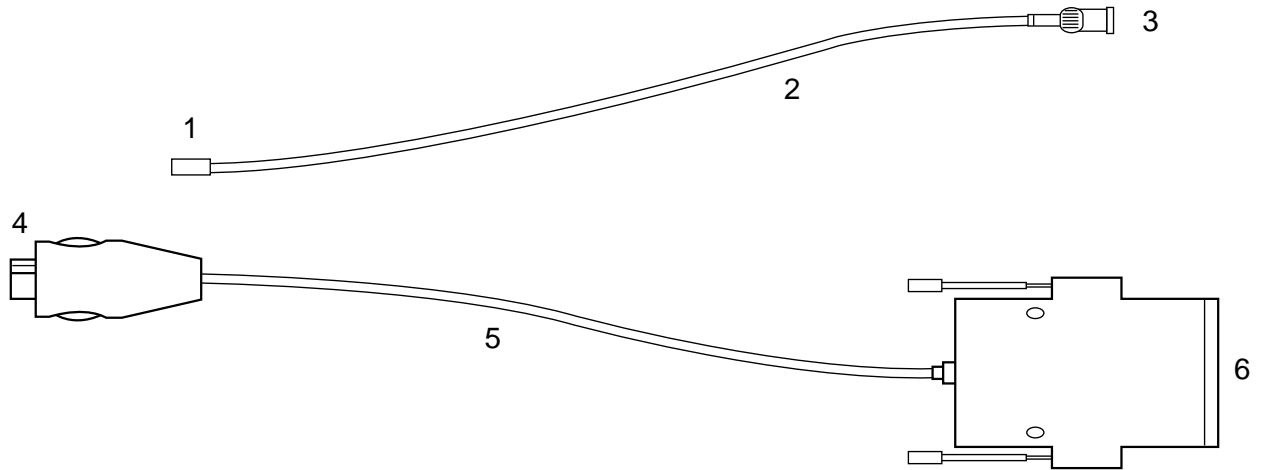

2. TEST CABLE CONNECTIONS

1	MHC 172
2	RF CABLE (1.4 dB Loss for AMPS, 2.2dB for PCS)
3	BNC CONNECTOR (RF)
4	PLUG CONNECT TO SCH-8500
5	DATA CABLE
6	Dsub 25PIN CONNECTOR (DATA)

3. Dsub 25 PIN CONNECTOR PIN DESCRIPTION (TEST CABLE 1, BACK SIDE)

DATA DESCRIPTION	Dsub CONN. PIN NO.	DATA DESCRIPTION	Dsub CONN. PIN NO.
V_F	12,21	DP_RX_DATA	8
DGND	2, 4, 6, 13, 19	HP_PWR	9
BATT	15, 16, 22	RI	10
C_F	3,20	CD	11
TX_AUDIO	5	RTS	14
DP_TX_DATA	7	CTS	17
RX_AUDIO	1	DTR	18

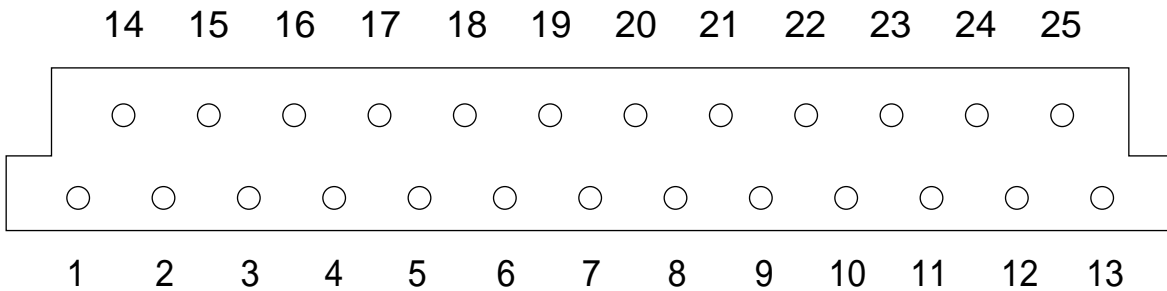

4. CONVERSION TABLE OF FREQUENCY vs CHANNEL

T Y P E	CHANNEL	CONVERSION EQUATION	REMARK
TX 1 FREQUENCY	$\leq N \leq 799$	$F=0.03 \times N + 825.00$	N ; CH NUMBER F ; FREQUENCY (AMPS)
	$990 \leq N \leq 1023$	$F=0.03 \times (N-1023) + 825.00$	
RX FREQUENCY	$1 \leq N \leq 799$	$F=0.03 \times N + 870.00$	N ; CH NUMBER F ; FREQUENCY (AMPS)
	$990 \leq N \leq 1023$	$F=0.03 \times (N-1023) + 870.00$	
TX FREQUENCY	$0 \leq N \leq 1199$	$F=0.05 \times N + 1850.00$	N ; CH NUMBER F ; FREQUENCY (PCS)
	$0 \leq N \leq 1199$	$F=0.05 \times N + 1930.00$ 2. CDMA	

4-4 Test Procedure

4-4-1 Change to Test Mode

A. To change the phone's state from Normal Mode to Test Mode, You should enter the following keys.
"4 7 * 8 6 9 # 1 2 3 5"

B. The command "20" is mode and channel change, press "OK" to save.
"10000" or "10001" : AMPS's Sytem A and Sytem B

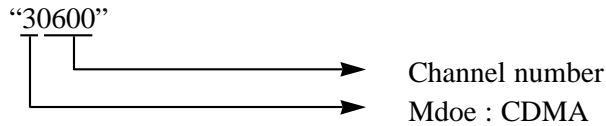

C. The command "0 1" is Suspend.

D. To finish the Test Mode, You should enter the command "0 2".

4-4-2 Channel Selection and Tx Power Output Level Control

1. AMPS(FM)

A. Enter to Test Mode (4 7 * 8 6 9 # 1 2 3 5).

B. The command "20" is mode and channel change
"10000" or "10001" : AMPS's Sytem A and Sytem B

C. To finish the Test Mode, You should enter the command "0 2".

D. "0 1" : Suspend.

E. "4 6" : Vocoder initial to Analog mode.

F. "0 9 0 3 6 3 #" : Set to '0363' channel.

G. "0 7" : Carrier On.

H. "9 2 * * * " : Output RF power level is set as power level 2
"* * *" means AGC level and AGC level range is from 0 to 511.

I. "1 0 2" : RF Power level control, 2(0~7) means power level .

2. PCS

A. Enter to Test Mode (4 7 * 8 6 9 # 1 2 3 5).

B. The command “20” is mode and channel change

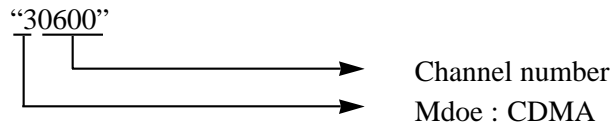

C. To finish the Test Mode, You should enter the command “0 2”.

D. “0 1” : Suspend.

E. “0 9 0 6 0 0 #” : Set to ‘0600’ channel.

F. “0 7” : Carrier On.

G. “3 4” : Spread spectrum to 1.23MHz band width.

H. “84” : High Power-mode On

I. “7 4 * * * *” : Output RF power level is set max power
“* * *” means AGC level and AGC level range is from 000 to 511.

4-5 Channel number

1. AMPS(FM)

TEST ITEMS	PROCEDURE														
1. PREPARATION	<p>Set test equipments up.</p> <p>Confirm that the phone is in the Analog Mode! (“10000” or “10001” at Test Command “2 0”.) “4 7 * 8 6 9 # 1 2 3 5 “ : Enter the Test Mode “0 1” : Suspend “4 6” : Initialize Vocoder in Analog mode If a wrong key would be selected, press “#”, and then enter new command. To exit the Test Mode at any time, just press [0 2].</p>														
2. RF POWER	<p>“0 1” : Suspend. “4 6” : Initialize Vocoder in Analog mode. “0 9 0 3 6 3 #” : Set channel to 363. “0 7” : Carrier On. “1 0 2” : RF Power level selection, “2” means one of the power levels (0~7). Measurement of the Power Output Levels</p> <table border="1" data-bbox="500 863 915 1083"> <thead> <tr> <th>Level</th> <th>RF Power</th> </tr> </thead> <tbody> <tr> <td>0 ~ 2</td> <td>+ 26 dBm +0.3/-4 dB</td> </tr> <tr> <td>3</td> <td>+ 23 dBm +2/-4 dB</td> </tr> <tr> <td>4</td> <td>+ 19 dBm +2/-4 dB</td> </tr> <tr> <td>5</td> <td>+ 15 dBm +2/-4 dB</td> </tr> <tr> <td>6</td> <td>+ 12 dBm +2/-4 dB</td> </tr> <tr> <td>7</td> <td>+ 9 dBm +2/-4 dB</td> </tr> </tbody> </table> <p>“0 8” : Carrier off</p> <p>Note 1 : In case of using the antenna cable, compensation for the cable loss should be added (about 1.5dB). Note 2 : To prevent phones from being damaged, they must be measured only by calibrated test equipments.</p> <p>Warning ! Adjustments without calibrated equipments can cause phones to be heated excessively and would void the warranty.</p>	Level	RF Power	0 ~ 2	+ 26 dBm +0.3/-4 dB	3	+ 23 dBm +2/-4 dB	4	+ 19 dBm +2/-4 dB	5	+ 15 dBm +2/-4 dB	6	+ 12 dBm +2/-4 dB	7	+ 9 dBm +2/-4 dB
Level	RF Power														
0 ~ 2	+ 26 dBm +0.3/-4 dB														
3	+ 23 dBm +2/-4 dB														
4	+ 19 dBm +2/-4 dB														
5	+ 15 dBm +2/-4 dB														
6	+ 12 dBm +2/-4 dB														
7	+ 9 dBm +2/-4 dB														
3. TX FREQUENCY	<p>“0 1” : Suspend. “4 6” : Initialize Vocoder in Analog mode. “0 9 0 3 6 3 #” : Set channel to 363. “0 7” : Carrier On. Measure the TX frequency : 835.89 MHz \pm2.5ppm.</p>														
4. VOICE DEVIATION	<p>“0 1” : Suspend. “4 6” : Initialize Vocoder in Analog mode. “0 9 0 3 6 3 #” : Set channel to 363. “0 7” : Carrier On. “1 4” : TX Audio unmute.</p> <p>Set the audio generator output to 1kHz, 3.0Vrms. Measure the Tx voice deviation by using the HPF of 20Hz and the LPF of 99kHz (spec : less than \pm12kHz).</p>														

TEST ITEMS	PROCEDURE
5. ST DEVIATION	<p>“0 1” : Suspend. “4 6” : Initialize Vocoder in Analog mode. “0 9 0 3 6 3 #” : Set channel to 363. “0 7” : Carrier On. “1 6” : ST on. Measure the Tx ST deviation by using the HPF of 50Hz (spec : 8kHz±10%).</p> <p>“1 7” : ST off.</p>
6. SAT DEVIATION	<p>“0 1” : Suspend. “4 6” : Initialize Vocoder in Analog mode. “0 9 0 3 6 3 #” : Set channel to 363. “0 7” : Carrier On. “3 2” : SAT on. Set the equipment as following. RF frequency : 880.89MHz Input RF level : -80dBm Modulation frequency : 6kHz Frequency deviation : 2kHz</p> <p>Measure the Tx SAT deviation by using the HPF of 50Hz and the LPF of 6kHz (spec : 2kHz±10%).</p> <p>“3 3” : SAT off.</p>
7. WBD DEVIATION	<p>“0 1” : Suspend. “4 6” : Initialize Vocoder in Analog mode. “0 9 0 3 6 3 #” : Set channel to 363. “0 7” : Carrier On. “3 4” : WBD on. Measure the WBD deviation by using the HPF of 50Hz and the LPF of 20kHz (spec : 8kHz±10%).</p>
8. RX AUDIO	<p>“0 1” : Suspend. “4 6” : Initialize Vocoder in Analog mode. “0 9 0 3 6 3 #” : Set channel to 363. “0 7” : Carrier On. “1 2” : RX Audio unmute. Set the equipment as following. RF frequency : 880.89MHz Input RF level : -80dBm Modulation frequency : 1kHz Frequency deviation : ±8kHz</p> <p>Measure audio AC level.</p>

2. PCS

TEST ITEMS	PROCEDURE
1. PREPARANCE	<p>Set test equipments up.</p> <p>Confirm that the phone is in the PCS Mode. (“3XXXX” at Test Command “0 2”)</p> <p>“* 4 7 * 8 6 9 # 1 2 3 5 “ : Enter the Test Mode “0 1” : Suspend If you select a wrong key, press “#”, then enter new command. To exit the Test Mode at any time, just press [0 2].</p>
2. FREQUENCY ACCURACY	<p>“0 1” : Suspend. “0 9 0 3 6 3 #” : Set channel to 363. “0 7” : Carrier On. “9 2” : You can read the number.(the code) and the push the “7 1 2 6 0 #” : Set AGC level to the numer of reading(about 188). Measure the TX frequency : 835.89MHz±300Hz.</p>
3. OCCUPIED CDMA BANDWIDTH	<p>“0 1” : Suspend.. “0 9 0 3 6 3 #” : Set channel to 363. “0 7” : Carrier On. “3 4” : Spread spectrum. “9 2” : You can read the number.(the code) and the push the “7 1 2 6 0 #” : Set AGC level to the numer of reading(about 188). Measure the bandwidth (spec: 1.32MHz).</p>
4. LIMITATIONS ON EMISSIONS	<p>“0 1” : Suspend. “0 9 0 3 6 3 #” : Set channel to 363. “0 7” : Carrier On. “3 4” : Spread spectrum. “9 2” : You can read the number.(the code) and the push the “7 1 2 6 0 #” : Set AGC level to the numer of reading(about 188).</p> <p>Measure the spurious at FC±900kHz, FC±1.98MHz, 2FC, 3FC, 1/2FC. spec: FC±900kHz below 42dBc/30kHz FC±1.98MHz below 54dBc/30kHz Outside Receive Band 43+10log (PY) PY: Mean Output Power in watts</p>
5. GATED POWER & TIME	<p>Set the service option 2. Set the data rate Eighth (1200bps). Registering: HHP → HP8924C. Call : HP8924C → HHP. Measure the Gated Power & Time. spec : Gated Power - at least 20dB Gated Time - Rising Time : below 6µs Falling Time : below 6µs Burst Time : below 1.25µs</p>

5. Exploded View & its Parts List

5-1 Main Set Exploded View

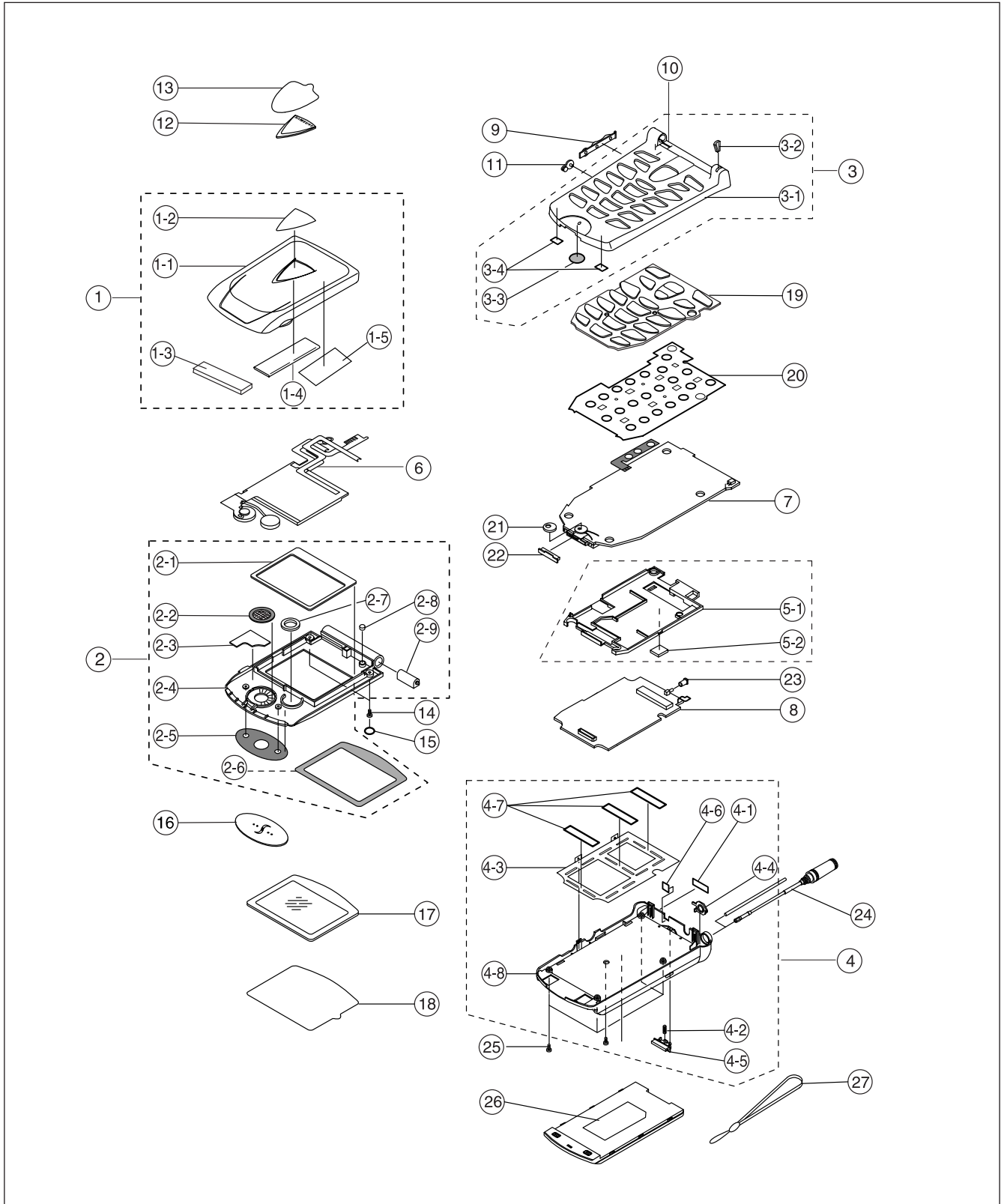

5-2 Main Set Parts List

NO	Level	SEC CODE	Description	Remark
1		GH75-00307A	MEA-FOLDER UPPER	
	1-1	GH72-00491A	PMO-FOLDER UPPER	SNA
	1-2	GH74-10772A	MPR-TAPE DECORATION	SNA
	1-3	GH74-00318A	MPR-SHIELD GASKET(B)	SNA
	1-4	GH74-00483A	MPR-SHIELD GASKET(C)	SNA
	1-5	GH74-00510A	MPR-TAPE SHIELD(D)	SNA
2		GH75-00376B	MEC-FOLDER LOWER	
	2-1	GH74-00319A	MPR-SPONGE LCD	SNA
	2-2	GH74-10777A	MPR-TAPE SPEAKER	SNA
	2-3	GH74-00322A	MPR-SPONGE EAR PIECE	SNA
	2-4	GH72-00671B	PMO-FOLDER LOWER	SNA
	2-5	GH74-00321A	MPR-TAPE EAR PIECE	SNA
	2-6	GH74-10775A	MPR-TAPE WINDOW LCD	SNA
	2-7	GH74-00304A	MPR-TAPE MOTOR	SNA
	2-8	GH70-00036A	ICT-MAGNETIC	SNA
2-9	GH75-00414A	MEC-HINGE ASSY	SNA	
3		GH75-00374B	MEC-FRONT COVER	
	3-1	GH72-00669B	PMO-FRONT COVER	SNA
	3-2	GH72-41801A	PMO-REFLECTOR LED	SNA
	3-3	GH74-00378A	MPR-FRONT GRILL	SNA
	3-4	GH74-00440A	MCT-FRONT GASKET	SNA
4		GH75-00377A	MEC-REAR COVER	
	4-1	GH68-30846A	LABEL(R)-QUALCOMM	SNA
	4-2	GH70-10516A	IPR-SPRING LOCKER	SNA
	4-3	GH71-00010A	NPR-GROUND PLATE	SNA
	4-4	GH71-00100A	NPR-BRACKET ANT	SNA
	4-5	GH72-00127A	PMO-BATT LOCKER	SNA
	4-6	GH72-00673A	PMO-REAR COVER	SNA
	4-7	GH74-00027A	MPR-SHIELD TAPE	SNA
	4-8	GH74-00377A	MPR-BUZZER GRILL	SNA
5		GH75-00394A	MEC-SHIELD COVER	
	5-1	GH72-00666A	PMO-SHIELD COVER	SNA
	5-2	GH74-00362A	MCT-SHIELD DUPLEX	SNA
6		GH96-00862A	ELA-GRAPHIC LCD	
7		GH92-00859A	PBA MAIN-LOGIC	
8		GH92-00763A	PBA MAIN-RF	
9		GH72-00487A	PMO-KNOB VOLUME	
10		GH72-00667A	PMO-HINGE DUMMY	
11		GH73-00217A	RMO-EAR JACK COVER	
12		GH72-00668A	PMO-DECORATION	
13		GH74-00084A	MPR-DECO BOHO VINYL	
14		6001-001300	SCREW-MACHINE	
15		GH74-00313B	MPR-SCREW CAP	
16		GH72-00672B	PMO-EAR PIECE	
17		GH72-00283E	PCT-WINDOW LCD	
18		GH72-10001A	PPR-TAPE WINDOW BOHO	
19		GH73-00216B	RMO-KEY PAD	
20		GH72-00489A	PPR-KEYPAD DOME	
21		GH73-00218A	RMO-HOLDER MIC	
22		GH73-40704A	RMO-CONNECTOR COVER	
23		GH73-40705A	RMO-MOBILE CAP	
24		GH42-00040A	ANTENNA	
25		6001-001140	SCREW-MACHINE	4PCS
26		GH43-00161A	BATTERY-STD	1000mAh
27		GH75-00223E	MEC-HANGER ROPE	BLACK

6. Electrical Parts List

SEC CODE	LOC NO.	DESCRIPTION	SPEC	REMARK
GH41-00066A		PCB-VOLUME KEY	SCH-8500,POLYIMIDE	
GH42-00040A	ANT.	ANTENNA-SCH8500/850	SCH-8500,824~894/1850~1990Mhz	
GH43-00161A		BATTERY-SCH850,8500(USA)	3.6V,1000mAh,-,0.5C,3.6V	
GH44-00099A		CHARGER-DTC850(USA)	SCH-850/8500,AC/DC,12W,85/264V	
GH96-00862A		ELA ETC-LCD ASS'Y	SCH-8500,GRAPHIC LCD	
GH41-00060A		PCB-LOGIC	SCH-8500,FR-4,-,0.8t,118 X 104mm	
GH41-00061A		PCB-RF	SCH-8500,FR-4,6L,0.8t,118 X 155	
0404-001093	D402	DIODE-SCHOTTKY	HSMS-282C,1V,30mA,SOT-323,TP	
0409-001001	D301	DIODE-PIN	BAR63-03W,50V,100mA,SOT-23,TP	
0409-001025	D302	DIODE-PIN	HSMP-389F,100V,1000mA,SOT-323,TP	
0409-001025	D303	DIODE-PIN	HSMP-389F,100V,1000mA,SOT-323,TP	
0409-001025	D401	DIODE-PIN	HSMP-389F,100V,1000mA,SOT-323,TP	
0501-000218	Q302	TR-SMALL SIGNAL	2SC4081,NPN,200mW,UMT,TP,180-3	
0504-000167	Q303	TR-DIGITAL	RN1102,NPN,100MW,10K/10K,SSM,TP	
0505-001361	Q301	FET-SILICON	ATF35143,-,5.5V,80MA,-,-,SOT-343	
0505-001376	U417	FET-SILICON	FDC6329L,N/P,8V,2.5A,-,0.7W,SC-74	
0505-001408	U408	FET-SILICON	FDC6306,P,-20V,0.16ohm,SSOT-6	
0505-001408	U416	FET-SILICON	FDC6306,P,-20V,0.16ohmSSOT-6	
0506-001004	U402	TR-ARRAY	UMC5N,NPN/PNP,2.50V,-,-,100mA,3	
0803-003010	U405	IC-TTL	4W53,MUX/DEMUX,SOP,8P,110MIL,S	
1201-001175	U404	IC-PREAMP	01037,SOP,6P,59MIL,SINGLE,-,PL	
1201-001348	U415	IC-OP AMP	821,SOT23-5,5P,63MIL,SINGLE,-,	
1201-001517	U302	IC-RF AMP	2361,SOT23-5,5P,-,SINGLE,20dB	
1201-001518	U409	IC-POWER AMP	QCPM9804,MULTIPAK,14P,-,TRIPLE	
1204-001013	U403	IC-MODULATOR	UPC8106T,SOT-23,6P,59MIL	
1205-001710	U301	IC-MIXER	NJG1553F,MTP,6P,-,EPOXY RESIN,5V	
1205-001773	U303	IC-MIXER	RF2466,MLP,16P,-,PLASTIC,4V	
1205-001775	U410	IC-MIXER	MRFIC1854,TSSOP,20P,173MIL	
2007-000138	R310	R-CHIP	100ohm,5%,1/16W,DA,TP,1005	
2007-000138	R322	R-CHIP	100ohm,5%,1/16W,DA,TP,1005	
2007-000138	R324	R-CHIP	100ohm,5%,1/16W,DA,TP,1005	
2007-000141	R456	R-CHIP	2.2Kohm,5%,1/16W,DA,TP,1005	
2007-000142	R314	R-CHIP	2.7Kohm,5%,1/16W,DA,TP,1005	
2007-000143	R315	R-CHIP	4.7Kohm,5%,1/16W,DA,TP,1005	
2007-000159	R457	R-CHIP	56Kohm,5%,1/16W,DA,TP,1005	
2007-000169	R429	R-CHIP	510Kohm,5%,1/16W,DA,TP,1005	
2007-000172	R333	R-CHIP	10ohm,5%,1/16W,DA,TP,1005	
2007-000174	R323	R-CHIP	47ohm,5%,1/16W,DA,TP,1005	
2007-000242	R328	R-CHIP	1.5Kohm,5%,1/16W,DA,TP,1005	
2007-000899	R455	R-CHIP	430Kohm,5%,1/16W,DA,TP,1005	
2007-000982	R410	R-CHIP	5.6Kohm,5%,1/16W,DA,TP,1005	
2007-001217	R313	R-CHIP	82ohm,5%,1/16W,DA,TP,1005	
2007-001284	R302	R-CHIP	4.7ohm,5%,1/16W,DA,TP,1005	
2007-001284	R303	R-CHIP	4.7ohm,5%,1/16W,DA,TP,1005	
2007-001288	R418	R-CHIP	18ohm,5%,1/16W,DA,TP,1005	

SEC CODE	LOC NO.	DESCRIPTION	SPEC	REMARK
2007-001298	R305	R-CHIP	51ohm,5%,1/16W,DA,TP,1005	
2007-001298	R432	R-CHIP	51ohm,5%,1/16W,DA,TP,1005	
2007-001317	R417	R-CHIP	910ohm,5%,1/16W,DA,TP,1005	
2007-001320	R434	R-CHIP	1.8Kohm,5%,1/16W,DA,TP,1005	
2007-002970	R301	R-CHIP	56OHM,5%,1/16W,DA,TP,1005	
2007-002970	R304	R-CHIP	56OHM,5%,1/16W,DA,TP,1005	
2007-003019	R306	R-CHIP	430OHM,5%,1/16W,DA,TP,1005	
2007-007001	R329	R-CHIP	3.9KOHM,5%,1/16W,DA,TP,1005	
2007-007001	R416	R-CHIP	3.9KOHM,5%,1/16W,DA,TP,1005	
2007-007014	R427	R-CHIP	51KOHM,5%,1/16W,DA,TP,1005	
2007-007107	R317	R-CHIP	100Kohm,1%,1/16W,DA,TP,1005	
2007-007107	R443	R-CHIP	100Kohm,1%,1/16W,DA,TP,1005	
2007-007133	R403	R-CHIP	300ohm,1%,1/16W,DA,TP,1005	
2007-007133	R406	R-CHIP	300ohm,1%,1/16W,DA,TP,1005	
2007-007137	R332	R-CHIP	1.2Kohm,1%,1/16W,DA,TP,1005	
2007-007139	R412	R-CHIP	47Kohm,1%,1/16W,DA,TP,1005	
2007-007142	R411	R-CHIP	10Kohm,1%,1/16W,DA,TP,1005	
2007-007142	R424	R-CHIP	10Kohm,1%,1/16W,DA,TP,1005	
2007-007142	R426	R-CHIP	10Kohm,1%,1/16W,DA,TP,1005	
2007-007142	R447	R-CHIP	10Kohm,1%,1/16W,DA,TP,1005	
2007-007142	R458	R-CHIP	10Kohm,1%,1/16W,DA,TP,1005	
2007-007517	R311	R-CHIP	240ohm,1%,1/16W,DA,TP,1005	
2007-007588	R319	R-CHIP	1.8Kohm,1%,1/16W,DA,TP,1005	
2007-007588	R320	R-CHIP	1.8Kohm,1%,1/16W,DA,TP,1005	
2007-007771	R307	R-CHIP	0OHM,5%,1/16W,DA,TP,1005	
2007-007771	R309	R-CHIP	0OHM,5%,1/16W,DA,TP,1005	
2007-007771	R312	R-CHIP	0OHM,5%,1/16W,DA,TP,1005	
2007-007771	R318	R-CHIP	0OHM,5%,1/16W,DA,TP,1005	
2007-007771	R321	R-CHIP	0OHM,5%,1/16W,DA,TP,1005	
2007-007771	R325	R-CHIP	0OHM,5%,1/16W,DA,TP,1005	
2007-007771	R326	R-CHIP	0OHM,5%,1/16W,DA,TP,1005	
2007-007771	R327	R-CHIP	0OHM,5%,1/16W,DA,TP,1005	
2007-007771	R402	R-CHIP	0OHM,5%,1/16W,DA,TP,1005	
2007-007771	R425	R-CHIP	0OHM,5%,1/16W,DA,TP,1005	
2007-007771	R428	R-CHIP	0OHM,5%,1/16W,DA,TP,1005	
2007-007771	R430	R-CHIP	0OHM,5%,1/16W,DA,TP,1005	
2203-000233	C312	C-CERAMIC,CHIP	0.1nF,5%,50V,NP0,TP,1005	
2203-000233	C316	C-CERAMIC,CHIP	0.1nF,5%,50V,NP0,TP,1005	
2203-000233	C326	C-CERAMIC,CHIP	0.1nF,5%,50V,NP0,TP,1005	
2203-000233	C331	C-CERAMIC,CHIP	0.1nF,5%,50V,NP0,TP,1005	
2203-000233	C369	C-CERAMIC,CHIP	0.1nF,5%,50V,NP0,TP,1005	
2203-000233	C370	C-CERAMIC,CHIP	0.1nF,5%,50V,NP0,TP,1005	
2203-000233	C373	C-CERAMIC,CHIP	0.1nF,5%,50V,NP0,TP,1005	
2203-000233	C410	C-CERAMIC,CHIP	0.1nF,5%,50V,NP0,TP,1005	
2203-000233	C421	C-CERAMIC,CHIP	0.1nF,5%,50V,NP0,TP,1005	
2203-000233	C431	C-CERAMIC,CHIP	0.1nF,5%,50V,NP0,TP,1005	
2203-000233	C465	C-CERAMIC,CHIP	0.1nF,5%,50V,NP0,TP,1005	
2203-000254	C314	C-CERAMIC,CHIP	10nF,10%,16V,X7R,TP,1005,-	
2203-000254	C315	C-CERAMIC,CHIP	10nF,10%,16V,X7R,TP,1005,-	

SEC CODE	LOC NO.	DESCRIPTION	SPEC	REMARK
2203-000254	C342	C-CERAMIC,CHIP	10nF,10%,16V,X7R,TP,1005,-	
2203-000254	C343	C-CERAMIC,CHIP	10nF,10%,16V,X7R,TP,1005,-	
2203-000254	C349	C-CERAMIC,CHIP	10nF,10%,16V,X7R,TP,1005,-	
2203-000254	C350	C-CERAMIC,CHIP	10nF,10%,16V,X7R,TP,1005,-	
2203-000254	C351	C-CERAMIC,CHIP	10nF,10%,16V,X7R,TP,1005,-	
2203-000254	C372	C-CERAMIC,CHIP	10nF,10%,16V,X7R,TP,1005,-	
2203-000254	C374	C-CERAMIC,CHIP	10nF,10%,16V,X7R,TP,1005,-	
2203-000254	C377	C-CERAMIC,CHIP	10nF,10%,16V,X7R,TP,1005,-	
2203-000254	C402	C-CERAMIC,CHIP	10nF,10%,16V,X7R,TP,1005,-	
2203-000254	C408	C-CERAMIC,CHIP	10nF,10%,16V,X7R,TP,1005,-	
2203-000254	C413	C-CERAMIC,CHIP	10nF,10%,16V,X7R,TP,1005,-	
2203-000254	C414	C-CERAMIC,CHIP	10nF,10%,16V,X7R,TP,1005,-	
2203-000254	C416	C-CERAMIC,CHIP	10nF,10%,16V,X7R,TP,1005,-	
2203-000254	C423	C-CERAMIC,CHIP	10nF,10%,16V,X7R,TP,1005,-	
2203-000254	C429	C-CERAMIC,CHIP	10nF,10%,16V,X7R,TP,1005,-	
2203-000254	C435	C-CERAMIC,CHIP	10nF,10%,16V,X7R,TP,1005,-	
2203-000254	C437	C-CERAMIC,CHIP	10nF,10%,16V,X7R,TP,1005,-	
2203-000254	C448	C-CERAMIC,CHIP	10nF,10%,16V,X7R,TP,1005,-	
2203-000254	C451	C-CERAMIC,CHIP	10nF,10%,16V,X7R,TP,1005,-	
2203-000254	C460	C-CERAMIC,CHIP	10nF,10%,16V,X7R,TP,1005,-	
2203-000254	C464	C-CERAMIC,CHIP	10nF,10%,16V,X7R,TP,1005,-	
2203-000278	C332	C-CERAMIC,CHIP	0.01nF,0.5pF,50V,NP0,TP,1005	
2203-000278	C341	C-CERAMIC,CHIP	0.01nF,0.5pF,50V,NP0,TP,1005	
2203-000330	C318	C-CERAMIC,CHIP	0.012nF,5%,50V,NP0,TP,1005	
2203-000330	C430	C-CERAMIC,CHIP	0.012nF,5%,50V,NP0,TP,1005	
2203-000386	C442	C-CERAMIC,CHIP	0.015nF,5%,50V,NP0,TP,1005	
2203-000425	C344	C-CERAMIC,CHIP	0.018nF,5%,50V,NP0,TP,1005	
2203-000425	C348	C-CERAMIC,CHIP	0.018nF,5%,50V,NP0,TP,1005	
2203-000438	C308	C-CERAMIC,CHIP	1nF,10%,50V,X7R,TP,1005,-	
2203-000438	C310	C-CERAMIC,CHIP	1nF,10%,50V,X7R,TP,1005,-	
2203-000438	C317	C-CERAMIC,CHIP	1nF,10%,50V,X7R,TP,1005,-	
2203-000438	C322	C-CERAMIC,CHIP	1nF,10%,50V,X7R,TP,1005,-	
2203-000438	C325	C-CERAMIC,CHIP	1nF,10%,50V,X7R,TP,1005,-	
2203-000438	C333	C-CERAMIC,CHIP	1nF,10%,50V,X7R,TP,1005,-	
2203-000438	C336	C-CERAMIC,CHIP	1nF,10%,50V,X7R,TP,1005,-	
2203-000438	C361	C-CERAMIC,CHIP	1nF,10%,50V,X7R,TP,1005,-	
2203-000438	C364	C-CERAMIC,CHIP	1nF,10%,50V,X7R,TP,1005,-	
2203-000438	C371	C-CERAMIC,CHIP	1nF,10%,50V,X7R,TP,1005,-	
2203-000438	C405	C-CERAMIC,CHIP	1nF,10%,50V,X7R,TP,1005,-	
2203-000438	C417	C-CERAMIC,CHIP	1nF,10%,50V,X7R,TP,1005,-	
2203-000438	C427	C-CERAMIC,CHIP	1nF,10%,50V,X7R,TP,1005,-	
2203-000438	C436	C-CERAMIC,CHIP	1nF,10%,50V,X7R,TP,1005,-	
2203-000438	C446	C-CERAMIC,CHIP	1nF,10%,50V,X7R,TP,1005,-	
2203-000438	C447	C-CERAMIC,CHIP	1nF,10%,50V,X7R,TP,1005,-	
2203-000438	C455	C-CERAMIC,CHIP	1nF,10%,50V,X7R,TP,1005,-	
2203-000438	C462	C-CERAMIC,CHIP	1nF,10%,50V,X7R,TP,1005,-	
2203-000466	C307	C-CERAMIC,CHIP	0.001nF,0.25pF,50V,NP0,1005	
2203-000466	C337	C-CERAMIC,CHIP	0.001nF,0.25pF,50V,NP0,1005	
2203-000466	C365	C-CERAMIC,CHIP	0.001nF,0.25pF,50V,NP0,1005	

SEC CODE	LOC NO.	DESCRIPTION	SPEC	REMARK
2203-000466	C420	C-CERAMIC,CHIP	0.001nF,0.25pF,50V,NP0,1005	
2203-000466	C457	C-CERAMIC,CHIP	0.001nF,0.25pF,50V,NP0,1005	
2203-000696	C302	C-CERAMIC,CHIP	0.001nF,0.25pF,50V,NP0,1005	
2203-000696	C362	C-CERAMIC,CHIP	0.001nF,0.25pF,50V,NP0,1005	
2203-000812	C403	C-CERAMIC,CHIP	0.033nF,5%,50V,NP0,TP,1005	
2203-000812	C415	C-CERAMIC,CHIP	0.033nF,5%,50V,NP0,TP,1005	
2203-000812	C418	C-CERAMIC,CHIP	0.033nF,5%,50V,NP0,TP,1005	
2203-000812	C426	C-CERAMIC,CHIP	0.033nF,5%,50V,NP0,TP,1005	
2203-000812	C434	C-CERAMIC,CHIP	0.033nF,5%,50V,NP0,TP,1005	
2203-000812	C441	C-CERAMIC,CHIP	0.033nF,5%,50V,NP0,TP,1005	
2203-000812	C444	C-CERAMIC,CHIP	0.033nF,5%,50V,NP0,TP,1005	
2203-000812	C450	C-CERAMIC,CHIP	0.033nF,5%,50V,NP0,TP,1005	
2203-000812	C459	C-CERAMIC,CHIP	0.033nF,5%,50V,NP0,TP,1005	
2203-000854	C323	C-CERAMIC,CHIP	0.039nF,5%,50V,NP0,TP,1005	
2203-000995	C407	C-CERAMIC,CHIP	0.047nF,5%,50V,NP0,TP,1005	
2203-000995	C438	C-CERAMIC,CHIP	0.047nF,5%,50V,NP0,TP,1005	
2203-000995	C461	C-CERAMIC,CHIP	0.047nF,5%,50V,NP0,TP,1005	
2203-001017	C313	C-CERAMIC,CHIP	0.004nF,0.25pF,50V,NP0,1005	
2203-001017	C428	C-CERAMIC,CHIP	0.004nF,0.25pF,50V,NP0,1005	
2203-001259	C324	C-CERAMIC,CHIP	0.008nF,0.5pF,50V,NP0,TP,1005	
2203-001412	C303	C-CERAMIC,CHIP	0.03nF,5%,50V,NP0,TP,1005	
2203-001412	C306	C-CERAMIC,CHIP	0.03nF,5%,50V,NP0,TP,1005	
2203-001416	C311	C-CERAMIC,CHIP	33nF,10%,16V,Y5V,TP,1005,1.0mm	
2203-001416	C320	C-CERAMIC,CHIP	33nF,10%,16V,Y5V,TP,1005,1.0mm	
2203-001416	C334	C-CERAMIC,CHIP	33nF,10%,16V,Y5V,TP,1005,1.0mm	
2203-001437	C340	C-CERAMIC,CHIP	5pF,0.25pF,50V,X7R,TP,1005,1.0	
2203-002525	C319	C-CERAMIC,CHIP	0.56nF,10%,50V,X7R,TP,1005	
2203-002525	C466	C-CERAMIC,CHIP	0.56nF,10%,50V,X7R,TP,1005	
2203-002677	C301	C-CERAMIC,CHIP	0.75pF,0.1pF,50V,CH,TP,1005,-	
2203-002968	C401	C-CERAMIC,CHIP	0.051nF,5%,50V,NP0,TP,1005	
2203-002968	C409	C-CERAMIC,CHIP	0.051nF,5%,50V,NP0,TP,1005	
2203-002968	C412	C-CERAMIC,CHIP	0.051nF,5%,50V,NP0,TP,1005	
2203-002968	C422	C-CERAMIC,CHIP	0.051nF,5%,50V,NP0,TP,1005	
2203-002968	C432	C-CERAMIC,CHIP	0.051nF,5%,50V,NP0,TP,1005	
2203-005057	C305	C-CERAMIC,CHIP	0.0082nF,0.25pF,50V,NP0,1005	
2203-005057	C309	C-CERAMIC,CHIP	0.0082nF,0.25pF,50V,NP0,1005	
2203-005061	C345	C-CERAMIC,CHIP	100nF,+80-20%,16V,Y5V,TP,1005	
2203-005061	C347	C-CERAMIC,CHIP	100nF,+80-20%,16V,Y5V,TP,1005	
2203-005061	C352	C-CERAMIC,CHIP	100nF,+80-20%,16V,Y5V,TP,1005	
2203-005061	C356	C-CERAMIC,CHIP	100nF,+80-20%,16V,Y5V,TP,1005	
2203-005061	C363	C-CERAMIC,CHIP	100nF,+80-20%,16V,Y5V,TP,1005	
2203-005061	C368	C-CERAMIC,CHIP	100nF,+80-20%,16V,Y5V,TP,1005	
2203-005061	C439	C-CERAMIC,CHIP	100nF,+80-20%,16V,Y5V,TP,1005	
2203-005061	C440	C-CERAMIC,CHIP	100nF,+80-20%,16V,Y5V,TP,1005	
2203-005061	C443	C-CERAMIC,CHIP	100nF,+80-20%,16V,Y5V,TP,1005	
2203-005281	C404	C-CERAMIC,CHIP	0.0015nF,0.1pF,50V,NP0,TP,1005	
2203-005281	C433	C-CERAMIC,CHIP	0.0015nF,0.1pF,50V,NP0,TP,1005	
2203-005288	C419	C-CERAMIC,CHIP	0.001nF,0.1pF,50V,NP0,TP,1005	
2203-005288	C454	C-CERAMIC,CHIP	0.001nF,0.1pF,50V,NP0,TP,1005	

SEC CODE	LOC NO.	DESCRIPTION	SPEC	REMARK
2203-005393	C328	C-CERAMIC,CHIP	0.005nF,0.1pF,50V,NP0,TP,1005	
2203-005393	C330	C-CERAMIC,CHIP	0.005nF,0.1pF,50V,NP0,TP,1005	
2203-005444	C321	C-CERAMIC,CHIP	0.003nF,0.1pF,50V,NP0,TP,1005	
2203-005481	C463	C-CERAMIC,CHIP	47nF,10%,10V,X7R,TP,1005,-	
2404-001017	C367	C-TA,CHIP	1uF,20%,10V,GP,TP,2012,2,0	
2404-001086	C327	C-TA,CHIP	4.7uF,20%,6.3V,GP,TP,2012,-	
2404-001105	C357	C-TA,CHIP	10UF,20%,6.3V,GP,TP,2012	
2404-001105	C358	C-TA,CHIP	10UF,20%,6.3V,GP,TP,2012	
2404-001105	C366	C-TA,CHIP	10UF,20%,6.3V,GP,TP,2012	
2404-001105	C375	C-TA,CHIP	10UF,20%,6.3V,GP,TP,2012	
2404-001105	C449	C-TA,CHIP	10UF,20%,6.3V,GP,TP,2012	
2703-000190	L326	INDUCTOR-SMD	330nH,10%,0.8x1.6x0.8mm	
2703-000213	L330	INDUCTOR-SMD	470nH,10%,0.8x1.6x0.8mm	
2703-000310	L328	INDUCTOR-SMD	1.8uH,10%,0.8x1.6x0.8mm	
2703-000310	L329	INDUCTOR-SMD	1.8uH,10%,0.8x1.6x0.8mm	
2703-000310	L331	INDUCTOR-SMD	1.8uH,10%,0.8x1.6x0.8mm	
2703-000310	L333	INDUCTOR-SMD	1.8uH,10%,0.8x1.6x0.8mm	
2703-001165	L301	INDUCTOR-SMD	4.7nH,10%,1.6x0.8x0.8mm	
2703-001178	L304	INDUCTOR-SMD	3.3nH,0.3nH,1x0.5x0.5mm	
2703-001178	L407	INDUCTOR-SMD	3.3nH,0.3nH,1x0.5x0.5mm	
2703-001178	L420	INDUCTOR-SMD	3.3nH,0.3nH,1x0.5x0.5mm	
2703-001180	L406	INDUCTOR-SMD	15nH,5%,1x0.5x0.5mm	
2703-001259	L327	INDUCTOR-SMD	47NH,5%,1.6X0.8X0.8MM	
2703-001293	L411	INDUCTOR-SMD	82nH,5%,1.6x0.8x0.8mm	
2703-001543	L318	INDUCTOR-SMD	33nH,5%,1.8x1.12x1.02mm	
2703-001595	L409	INDUCTOR-SMD	47nH,5%,1.0x0.5x0.5mm	
2703-001595	L416	INDUCTOR-SMD	47nH,5%,1.0x0.5x0.5mm	
2703-001595	L417	INDUCTOR-SMD	47nH,5%,1.0x0.5x0.5mm	
2703-001701	L405	INDUCTOR-SMD	6.8nH,10%,1.0x0.5x0.5mm	
2703-001726	L313	INDUCTOR-SMD	27nH,5%,1x0.5x0.5mm	
2703-001726	L316	INDUCTOR-SMD	27nH,5%,1x0.5x0.5mm	
2703-001726	L317	INDUCTOR-SMD	27nH,5%,1x0.5x0.5mm	
2703-001728	L423	INDUCTOR-SMD	1.5nH,0.3nH,1x0.5x0.5mm	
2703-001730	L310	INDUCTOR-SMD	15nH,5%,1x0.5x0.5mm	
2703-001730	L419	INDUCTOR-SMD	15nH,5%,1x0.5x0.5mm	
2703-001747	L312	INDUCTOR-SMD	4.7nH,0.3nH,1.0x0.5x0.5mm	
2703-001748	L305	INDUCTOR-SMD	5.6nH,0.3nH,1.0x0.5x0.5mm	
2703-001751	L303	INDUCTOR-SMD	3.9nH,0.3nH,1.0x0.5x0.5mm	
2703-001751	L307	INDUCTOR-SMD	3.9nH,0.3nH,1.0x0.5x0.5mm	
2703-001752	L315	INDUCTOR-SMD	39nH,5%,1.0x0.5x0.5mm	
2703-001798	L422	INDUCTOR-SMD	2.2NH,0.3NH,1.0X0.5X0.5MM	
2703-001868	L401	INDUCTOR-SMD	82NH,5%,1005	
2703-001868	L408	INDUCTOR-SMD	82NH,5%,1005	
2703-001916	L402	INDUCTOR-SMD	100nH,2%,1.6x0.8x0.8mm	
2703-001918	L322	INDUCTOR-SMD	150nH,2%,1.6x0.8x0.8mm	
2703-001920	L412	INDUCTOR-SMD	2.2uH,20%,3.2x2.5x2.0mm	
2703-001943	L308	INDUCTOR-SMD	10nH,5%,1.0x0.5x0.5mm	
2703-001943	L309	INDUCTOR-SMD	10nH,5%,1.0x0.5x0.5mm	
2703-001952	L314	INDUCTOR-SMD	8.2nH,5%,1.0x0.5x0.5mm	

SEC CODE	LOC NO.	DESCRIPTION	SPEC	REMARK
2809-001228	U307	OSCILLATOR-VCTCXO	19.68MHZ,2PPM,-,TP,2.8V,2MA	
2904-001020	F403	FILTER-SAW	1.88GHz,60MHz,+30MHz/2.5dB	
2904-001020	F405	FILTER-SAW	1.88GHz,60MHz,+30MHz/2.5dB	
2904-001021	F302	FILTER-SAW	1.96GHz,60MHz,+30MHz/2dB	
2904-001109	F304	FILTER-SAW	1747.5MHz,+30MHz,1.2dB,TP,2.5	
2904-001123	F401	FILTER-SAW	130.38MHz,1.25MHz,+0MHz/8dB	
2904-001136	F306	FILTER-SAW	881.5MHz,25MHz,+12.5MHz/1.6dB	
2904-001138	F402	FILTER-SAW	836.5MHz,25MHz,+12.5MHz/2dB	
2904-001138	F404	FILTER-SAW	836.5MHz,25MHz,+12.5MHz/2dB	
2904-001148	F310	FILTER-SAW	85.38MHz,0.026MHz,+0.013MHz/1.5dB	
2904-001191	F308	FILTER-SAW	210.38MHz,0.6MHz,+0.3MHz/1.3dB	
2909-001082	F305	FILTER-DUPLEXER	881.5MHz,836.5MHz,3.8/2DB	
2909-001115	F303	FILTER-DUPLEXER	1.96GHz,1.88GHz,4.2/3.6dB	
3301-001105	L306	CORE-FERRITE	AB,1.6x0.8x0.8mm,-,-	
3301-001105	L319	CORE-FERRITE	AB,1.6x0.8x0.8mm,-,-	
3301-001105	L323	CORE-FERRITE	AB,1.6x0.8x0.8mm,-,-	
3301-001105	L334	CORE-FERRITE	AB,1.6x0.8x0.8mm,-,-	
3301-001105	L335	CORE-FERRITE	AB,1.6x0.8x0.8mm,-,-	
3301-001105	L404	CORE-FERRITE	AB,1.6x0.8x0.8mm,-,-	
3301-001105	L413	CORE-FERRITE	AB,1.6x0.8x0.8mm,-,-	
3301-001105	L414	CORE-FERRITE	AB,1.6x0.8x0.8mm,-,-	
3301-001105	L418	CORE-FERRITE	AB,1.6x0.8x0.8mm,-,-	
3301-001105	L421	CORE-FERRITE	AB,1.6x0.8x0.8mm,-,-	
3301-001120	L424	CORE-FERRITE BEAD	AB,2.0x1.25x0.9mm,-,-	
3705-001163	J1	CONNECTOR-COAXIAL	SMC,JACK,100mohm,50ohm,0.5dB	
3710-001535	CN401	CONNECTOR-SOCKET	40P,2R,0.5MM,SMD-S,AUF	
4709-001080	U304	RF POWER SPLITTER	2WAY,955-979MHz,12dB,-,TP	
4709-001119	U305	RF POWER SPLITTER	2WAY,1.5-1.9GHz,12dB,4.0dB,TP	
4709-001145	F301	FREQ-SEPARATOR	824-894MHz,1850-1990MHz,1W,3.2	
4709-001200	F406	FREQ-ISOLATOR	1850-1910 MHz,14dB,0.6dB,1.6	
4709-001201	F407	FREQ-ISOLATOR	824-849MHz,13dB,0.65dB,1.5	
4719-001049	U306	MODULE	PLL MODULE,1720-1780MHz,510MHz	
0405-001035	D202	DIODE-VARACTOR	1SV279,15V,3nA,USC,TP	
0405-001035	D203	DIODE-VARACTOR	1SV279,15V,3nA,USC,TP	
0405-001035	D204	DIODE-VARACTOR	1SV279,15V,3nA,USC,TP	
0405-001035	D205	DIODE-VARACTOR	1SV279,15V,3nA,USC,TP	
0406-001005	D111	DIODE-TVS	SM05,6V/1mA,300,SOT-23	
0406-001084	D102	DIODE-TVS	SMF05,6/-/V,200W,-	
0406-001084	D105	DIODE-TVS	SMF05,6/-/V,200W,-	
0406-001084	D106	DIODE-TVS	SMF05,6/-/V,200W,-	
0406-001084	D107	DIODE-TVS	SMF05,6/-/V,200W,-	
0406-001084	D108	DIODE-TVS	SMF05,6/-/V,200W,-	
0406-001084	D109	DIODE-TVS	SMF05,6/-/V,200W,-	
0407-000115	D110	DIODE-ARRAY	DAN202U,80V,100mA,CA2-3,SC-70,	
0409-001016	D201	DIODE-PIN	BAR63-02W,50V,100mA,SCD-80,TP	
0501-000162	Q104	TR-SMALL SIGNAL	2SA1576,PNP,200MW,SOT-323,TP,180-390	
0501-000218	Q103	TR-SMALL SIGNAL	2SC4081,NPN,200mW,UMT,TP,180-3	
0501-000218	Q151	TR-SMALL SIGNAL	2SC4081,NPN,200mW,UMT,TP,180-3	
0501-002202	Q102	TR-SMALL SIGNAL	MMBT2222AWT1,NPN,150mW,SOT-323	

SEC CODE	LOC NO.	DESCRIPTION	SPEC	REMARK
0501-002202	Q111	TR-SMALL SIGNAL	MMBT2222AWT1,NPN,150mW,SOT-323	
0504-000167	Q150	TR-DIGITAL	RN1102,NPN,100MW,10K/10K,SSM,TP	
0504-000168	Q101	TR-DIGITAL	RN1104,NPN,100MW,47K/47K,SSM,TP	
0504-000168	Q152	TR-DIGITAL	RN1104,NPN,100MW,47K/47K,SSM,TP	
0504-000172	Q110	TR-DIGITAL	RN2104,PNP,100MW,47K/47K,SSM,TP	
0504-000172	Q153	TR-DIGITAL	RN2104,PNP,100MW,47K/47K,SSM,TP	
0505-001037	U150	FET-SILICON	-,P,-12V,+2.5A,0.1ohm,1W,TSSO	
0505-001376	U151	FET-SILICON	FDC6329L,N/P,8V,2.5A,-,0.7W,SC-74	
0505-001376	U156	FET-SILICON	FDC6329L,N/P,8V,2.5A,-,0.7W,SC-74	
0505-001376	U157	FET-SILICON	FDC6329L,N/P,8V,2.5A,-,0.7W,SC-74	
0505-001376	U160	FET-SILICON	FDC6329L,N/P,8V,2.5A,-,0.7W,SC-74	
0601-000355	D101	LED	CHIP,RED,2.0x1.6mm,660nm	
0601-001343	LED100	LED	CHIP,Y-GRN,1.1X0.8MM,570NM	
0601-001343	LED101	LED	CHIP,Y-GRN,1.1X0.8MM,570NM	
0601-001343	LED102	LED	CHIP,Y-GRN,1.1X0.8MM,570NM	
0601-001343	LED103	LED	CHIP,Y-GRN,1.1X0.8MM,570NM	
0601-001343	LED104	LED	CHIP,Y-GRN,1.1X0.8MM,570NM	
0601-001343	LED105	LED	CHIP,Y-GRN,1.1X0.8MM,570NM	
0601-001343	LED106	LED	CHIP,Y-GRN,1.1X0.8MM,570NM	
0601-001343	LED107	LED	CHIP,Y-GRN,1.1X0.8MM,570NM	
0801-000794	U203	IC-CMOS LOGIC	7S08,AND GATE,SOT-25,5P,63MIL,	
0801-002345	U158	IC-CMOS LOGIC	7S04FU,INVERTER,SOP,5P,-,TP,	
0801-002403	U104	IC-CMOS LOGIC	74LCX08,AND GATE,TSSOP,14P,173	
1009-001006	SW101	IC-HALL EFFECT S/W	A3210ELH,SC-74A,3P	
1103-001147	U105	IC-EEPROM	24256,256KBIT,SOP,8P	
1109-001138	U103	IC-ETC. MEMORY	84VD2219,4MX8 OR 2MX16BIT,BGA	
1202-001022	U251	IC-VOLTAGE COMP.	75W56,SSOP,8P,110MIL,DUAL,7V,C	
1203-001767	U153	IC-VOLTAGE REGULATOR	2988,SOP,8P,118MIL,3.0V	
1203-001850	U154	IC-VOLTAGE REGULATOR	7082,SOT-23,5P	
1203-001850	U155	IC-VOLTAGE REGULATOR	7082,SOT-23,5P	
1203-001850	U159	IC-VOLTAGE REGULATOR	7082,SOT-23,5P	
1204-001375	U250	IC-ENCODER/DECODER	ST5092TOFPTR,QFP,44P,-,PLASTIC	
1204-001581	U201	IC-IF CIRCUIT	IFR3000-48BCCF-TR,BCC,48P	
1204-001582	U202	IC-IF CIRCUIT	IFT3000-48BCCF-TR,BCC,48P	
1205-001670	U101	IC-TRANSCEIVER	MSM3000,PBGA,196P,3.5V,30TO+85C	
1404-001040	TH201	THERMISTOR-NTC	10Kohm,5%,3650K,-,TP	
2007-000137	R259	R-CHIP	2Kohm,5%,1/16W,DA,TP,1005	
2007-000138	R109	R-CHIP	100ohm,5%,1/16W,DA,TP,1005	
2007-000138	R122	R-CHIP	100ohm,5%,1/16W,DA,TP,1005	
2007-000138	R124	R-CHIP	100ohm,5%,1/16W,DA,TP,1005	
2007-000138	R125	R-CHIP	100ohm,5%,1/16W,DA,TP,1005	
2007-000138	R128	R-CHIP	100ohm,5%,1/16W,DA,TP,1005	
2007-000138	R129	R-CHIP	100ohm,5%,1/16W,DA,TP,1005	
2007-000138	R131	R-CHIP	100ohm,5%,1/16W,DA,TP,1005	
2007-000138	R132	R-CHIP	100ohm,5%,1/16W,DA,TP,1005	
2007-000138	R149	R-CHIP	100ohm,5%,1/16W,DA,TP,1005	
2007-000138	R209	R-CHIP	100ohm,5%,1/16W,DA,TP,1005	
2007-000140	R148	R-CHIP	1Kohm,5%,1/16W,DA,TP,1005	
2007-000140	R169	R-CHIP	1Kohm,5%,1/16W,DA,TP,1005	

SEC CODE	LOC NO.	DESCRIPTION	SPEC	REMARK
2007-000140	R180	R-CHIP	1Kohm,5%,1/16W,DA,TP,1005	
2007-000140	R252	R-CHIP	1Kohm,5%,1/16W,DA,TP,1005	
2007-000141	R152	R-CHIP	2.2Kohm,5%,1/16W,DA,TP,1005	
2007-000141	R153	R-CHIP	2.2Kohm,5%,1/16W,DA,TP,1005	
2007-000141	R159	R-CHIP	2.2Kohm,5%,1/16W,DA,TP,1005	
2007-000141	R190	R-CHIP	2.2Kohm,5%,1/16W,DA,TP,1005	
2007-000141	R192	R-CHIP	2.2Kohm,5%,1/16W,DA,TP,1005	
2007-000141	R251	R-CHIP	2.2Kohm,5%,1/16W,DA,TP,1005	
2007-000143	R110	R-CHIP	4.7Kohm,5%,1/16W,DA,TP,1005	
2007-000143	R126	R-CHIP	4.7Kohm,5%,1/16W,DA,TP,1005	
2007-000145	R261	R-CHIP	6.2Kohm,5%,1/16W,DA,TP,1005	
2007-000147	R142	R-CHIP	8.2Kohm,5%,1/16W,DA,TP,1005	
2007-000147	R205	R-CHIP	8.2Kohm,5%,1/16W,DA,TP,1005	
2007-000148	R112	R-CHIP	10Kohm,5%,1/16W,DA,TP,1005	
2007-000148	R115	R-CHIP	10Kohm,5%,1/16W,DA,TP,1005	
2007-000148	R120	R-CHIP	10Kohm,5%,1/16W,DA,TP,1005	
2007-000148	R138	R-CHIP	10Kohm,5%,1/16W,DA,TP,1005	
2007-000148	R165	R-CHIP	10Kohm,5%,1/16W,DA,TP,1005	
2007-000148	R206	R-CHIP	10Kohm,5%,1/16W,DA,TP,1005	
2007-000148	R207	R-CHIP	10Kohm,5%,1/16W,DA,TP,1005	
2007-000148	R210	R-CHIP	10Kohm,5%,1/16W,DA,TP,1005	
2007-000148	R213	R-CHIP	10Kohm,5%,1/16W,DA,TP,1005	
2007-000148	R215	R-CHIP	10Kohm,5%,1/16W,DA,TP,1005	
2007-000148	R216	R-CHIP	10Kohm,5%,1/16W,DA,TP,1005	
2007-000148	R220	R-CHIP	10Kohm,5%,1/16W,DA,TP,1005	
2007-000148	R226	R-CHIP	10Kohm,5%,1/16W,DA,TP,1005	
2007-000148	R249	R-CHIP	10Kohm,5%,1/16W,DA,TP,1005	
2007-000148	R250	R-CHIP	10Kohm,5%,1/16W,DA,TP,1005	
2007-000151	R147	R-CHIP	15Kohm,5%,1/16W,DA,TP,1005	
2007-000152	R133	R-CHIP	20Kohm,5%,1/16W,DA,TP,1005	
2007-000152	R134	R-CHIP	20Kohm,5%,1/16W,DA,TP,1005	
2007-000152	R135	R-CHIP	20Kohm,5%,1/16W,DA,TP,1005	
2007-000152	R136	R-CHIP	20Kohm,5%,1/16W,DA,TP,1005	
2007-000152	R254	R-CHIP	20Kohm,5%,1/16W,DA,TP,1005	
2007-000153	R107	R-CHIP	22Kohm,5%,1/16W,DA,TP,1005	
2007-000153	R113	R-CHIP	22Kohm,5%,1/16W,DA,TP,1005	
2007-000153	R123	R-CHIP	22Kohm,5%,1/16W,DA,TP,1005	
2007-000153	R145	R-CHIP	22Kohm,5%,1/16W,DA,TP,1005	
2007-000153	R164	R-CHIP	22Kohm,5%,1/16W,DA,TP,1005	
2007-000153	R173	R-CHIP	22Kohm,5%,1/16W,DA,TP,1005	
2007-000153	R174	R-CHIP	22Kohm,5%,1/16W,DA,TP,1005	
2007-000153	R175	R-CHIP	22Kohm,5%,1/16W,DA,TP,1005	
2007-000153	R176	R-CHIP	22Kohm,5%,1/16W,DA,TP,1005	
2007-000153	R179	R-CHIP	22Kohm,5%,1/16W,DA,TP,1005	
2007-000154	R257	R-CHIP	24Kohm,5%,1/16W,DA,TP,1005	
2007-000156	R225	R-CHIP	30Kohm,5%,1/16W,DA,TP,1005	
2007-000157	R117	R-CHIP	47Kohm,5%,1/16W,DA,TP,1005	
2007-000157	R118	R-CHIP	47Kohm,5%,1/16W,DA,TP,1005	
2007-000159	R150	R-CHIP	56Kohm,5%,1/16W,DA,TP,1005	

SEC CODE	LOC NO.	DESCRIPTION	SPEC	REMARK
2007-000159	R158	R-CHIP	56Kohm,5%,1/16W,DA,TP,1005	
2007-000159	R181	R-CHIP	56Kohm,5%,1/16W,DA,TP,1005	
2007-000159	R182	R-CHIP	56Kohm,5%,1/16W,DA,TP,1005	
2007-000159	R186	R-CHIP	56Kohm,5%,1/16W,DA,TP,1005	
2007-000162	R151	R-CHIP	100Kohm,5%,1/16W,DA,TP,1005	
2007-000162	R154	R-CHIP	100Kohm,5%,1/16W,DA,TP,1005	
2007-000162	R155	R-CHIP	100Kohm,5%,1/16W,DA,TP,1005	
2007-000162	R156	R-CHIP	100Kohm,5%,1/16W,DA,TP,1005	
2007-000162	R160	R-CHIP	100Kohm,5%,1/16W,DA,TP,1005	
2007-000162	R162	R-CHIP	100Kohm,5%,1/16W,DA,TP,1005	
2007-000162	R170	R-CHIP	100Kohm,5%,1/16W,DA,TP,1005	
2007-000162	R183	R-CHIP	100Kohm,5%,1/16W,DA,TP,1005	
2007-000162	R184	R-CHIP	100Kohm,5%,1/16W,DA,TP,1005	
2007-000163	R256	R-CHIP	120Kohm,5%,1/16W,DA,TP,1005	
2007-000164	R253	R-CHIP	150Kohm,5%,1/16W,DA,TP,1005	
2007-000165	R157	R-CHIP	200Kohm,5%,1/16W,DA,TP,1005	
2007-000170	R262	R-CHIP	1Mohm,5%,1/16W,DA,TP,1005	
2007-000172	R230	R-CHIP	10ohm,5%,1/16W,DA,TP,1005	
2007-000172	R231	R-CHIP	10ohm,5%,1/16W,DA,TP,1005	
2007-000242	R166	R-CHIP	1.5Kohm,5%,1/16W,DA,TP,1005	
2007-000758	R161	R-CHIP	330Kohm,5%,1/16W,DA,TP,1005	
2007-000932	R114	R-CHIP	470ohm,5%,1/16W,DA,TP,1005	
2007-001291	R266	R-CHIP	30ohm,5%,1/16W,DA,TP,1005	
2007-001305	R101	R-CHIP	120ohm,5%,1/16W,DA,TP,1005	
2007-001319	R221	R-CHIP	1.2Kohm,5%,1/16W,DA,TP,1005	
2007-001320	R219	R-CHIP	1.8Kohm,5%,1/16W,DA,TP,1005	
2007-001325	R106	R-CHIP	3.3Kohm,5%,1/16W,DA,TP,1005	
2007-001333	R255	R-CHIP	18Kohm,5%,1/16W,DA,TP,1005	
2007-003010	R104	R-CHIP	20OHM,5%,1/16W,DA,TP,1005	
2007-003010	R105	R-CHIP	20OHM,5%,1/16W,DA,TP,1005	
2007-003010	R258	R-CHIP	20OHM,5%,1/16W,DA,TP,1005	
2007-003019	R218	R-CHIP	430OHM,5%,1/16W,DA,TP,1005	
2007-007021	R202	R-CHIP	75KOHM,5%,1/16W,DA,TP,1005	
2007-007092	R143	R-CHIP	1.1KOHM,5%,1/16W,DA,TP,1005	
2007-007137	R227	R-CHIP	1.2Kohm,1%,1/16W,DA,TP,1005	
2007-007142	R127	R-CHIP	10Kohm,1%,1/16W,DA,TP,1005	
2007-007142	R187	R-CHIP	10Kohm,1%,1/16W,DA,TP,1005	
2007-007142	R191	R-CHIP	10Kohm,1%,1/16W,DA,TP,1005	
2007-007142	R193	R-CHIP	10Kohm,1%,1/16W,DA,TP,1005	
2007-007142	R194	R-CHIP	10Kohm,1%,1/16W,DA,TP,1005	
2007-007142	R214	R-CHIP	10Kohm,1%,1/16W,DA,TP,1005	
2007-007142	R217	R-CHIP	10Kohm,1%,1/16W,DA,TP,1005	
2007-007142	R222	R-CHIP	10Kohm,1%,1/16W,DA,TP,1005	
2007-007309	R223	R-CHIP	12Kohm,1%,1/16W,DA,TP,1005	
2007-007311	R102	R-CHIP	22Kohm,1%,1/16W,DA,TP,1005	
2007-007311	R201	R-CHIP	22Kohm,1%,1/16W,DA,TP,1005	
2007-007318	R103	R-CHIP	1Kohm,1%,1/16W,DA,TP,1005	
2007-007491	R224	R-CHIP	11.3Kohm,1%,1/16W,DA,TP,1005	
2007-007588	R208	R-CHIP	1.8Kohm,1%,1/16W,DA,TP,1005	

SEC CODE	LOC NO.	DESCRIPTION	SPEC	REMARK
2007-007771	R168	R-CHIP	0OHM,5%,1/16W,DA,TP,1005	
2007-007771	R196	R-CHIP	0OHM,5%,1/16W,DA,TP,1005	
2007-007771	R211	R-CHIP	0OHM,5%,1/16W,DA,TP,1005	
2203-000189	C258	C-CERAMIC,CHIP	100nF,+80-20%,25V,Y5V,TP,1608,	
2203-000233	C109	C-CERAMIC,CHIP	0.1nF,5%,50V,NP0,TP,1005	
2203-000233	C116	C-CERAMIC,CHIP	0.1nF,5%,50V,NP0,TP,1005	
2203-000233	C117	C-CERAMIC,CHIP	0.1nF,5%,50V,NP0,TP,1005	
2203-000233	C118	C-CERAMIC,CHIP	0.1nF,5%,50V,NP0,TP,1005	
2203-000233	C201	C-CERAMIC,CHIP	0.1nF,5%,50V,NP0,TP,1005	
2203-000233	C240	C-CERAMIC,CHIP	0.1nF,5%,50V,NP0,TP,1005	
2203-000233	C244	C-CERAMIC,CHIP	0.1nF,5%,50V,NP0,TP,1005	
2203-000233	C247	C-CERAMIC,CHIP	0.1nF,5%,50V,NP0,TP,1005	
2203-000254	C101	C-CERAMIC,CHIP	10nF,10%,16V,X7R,TP,1005,-	
2203-000254	C103	C-CERAMIC,CHIP	10nF,10%,16V,X7R,TP,1005,-	
2203-000254	C105	C-CERAMIC,CHIP	10nF,10%,16V,X7R,TP,1005,-	
2203-000254	C107	C-CERAMIC,CHIP	10nF,10%,16V,X7R,TP,1005,-	
2203-000254	C108	C-CERAMIC,CHIP	10nF,10%,16V,X7R,TP,1005,-	
2203-000254	C120	C-CERAMIC,CHIP	10nF,10%,16V,X7R,TP,1005,-	
2203-000254	C128	C-CERAMIC,CHIP	10nF,10%,16V,X7R,TP,1005,-	
2203-000254	C158	C-CERAMIC,CHIP	10nF,10%,16V,X7R,TP,1005,-	
2203-000254	C166	C-CERAMIC,CHIP	10nF,10%,16V,X7R,TP,1005,-	
2203-000254	C167	C-CERAMIC,CHIP	10nF,10%,16V,X7R,TP,1005,-	
2203-000254	C203	C-CERAMIC,CHIP	10nF,10%,16V,X7R,TP,1005,-	
2203-000254	C205	C-CERAMIC,CHIP	10nF,10%,16V,X7R,TP,1005,-	
2203-000254	C209	C-CERAMIC,CHIP	10nF,10%,16V,X7R,TP,1005,-	
2203-000254	C211	C-CERAMIC,CHIP	10nF,10%,16V,X7R,TP,1005,-	
2203-000254	C213	C-CERAMIC,CHIP	10nF,10%,16V,X7R,TP,1005,-	
2203-000254	C215	C-CERAMIC,CHIP	10nF,10%,16V,X7R,TP,1005,-	
2203-000254	C217	C-CERAMIC,CHIP	10nF,10%,16V,X7R,TP,1005,-	
2203-000254	C219	C-CERAMIC,CHIP	10nF,10%,16V,X7R,TP,1005,-	
2203-000254	C223	C-CERAMIC,CHIP	10nF,10%,16V,X7R,TP,1005,-	
2203-000254	C234	C-CERAMIC,CHIP	10nF,10%,16V,X7R,TP,1005,-	
2203-000254	C253	C-CERAMIC,CHIP	10nF,10%,16V,X7R,TP,1005,-	
2203-000254	C263	C-CERAMIC,CHIP	10nF,10%,16V,X7R,TP,1005,-	
2203-000254	C298	C-CERAMIC,CHIP	10nF,10%,16V,X7R,TP,1005,-	
2203-000386	C179	C-CERAMIC,CHIP	0.015nF,5%,50V,NP0,TP,1005	
2203-000386	C231	C-CERAMIC,CHIP	0.015nF,5%,50V,NP0,TP,1005	
2203-000386	C232	C-CERAMIC,CHIP	0.015nF,5%,50V,NP0,TP,1005	
2203-000386	C282	C-CERAMIC,CHIP	0.015nF,5%,50V,NP0,TP,1005	
2203-000386	C283	C-CERAMIC,CHIP	0.015nF,5%,50V,NP0,TP,1005	
2203-000386	C284	C-CERAMIC,CHIP	0.015nF,5%,50V,NP0,TP,1005	
2203-000386	C285	C-CERAMIC,CHIP	0.015nF,5%,50V,NP0,TP,1005	
2203-000386	C286	C-CERAMIC,CHIP	0.015nF,5%,50V,NP0,TP,1005	
2203-000386	C287	C-CERAMIC,CHIP	0.015nF,5%,50V,NP0,TP,1005	
2203-000386	C288	C-CERAMIC,CHIP	0.015nF,5%,50V,NP0,TP,1005	
2203-000386	C289	C-CERAMIC,CHIP	0.015nF,5%,50V,NP0,TP,1005	
2203-000386	C290	C-CERAMIC,CHIP	0.015nF,5%,50V,NP0,TP,1005	
2203-000386	C291	C-CERAMIC,CHIP	0.015nF,5%,50V,NP0,TP,1005	
2203-000386	C292	C-CERAMIC,CHIP	0.015nF,5%,50V,NP0,TP,1005	

SEC CODE	LOC NO.	DESCRIPTION	SPEC	REMARK
2203-000386	C293	C-CERAMIC,CHIP	0.015nF,5%,50V,NP0,TP,1005	
2203-000386	C295	C-CERAMIC,CHIP	0.015nF,5%,50V,NP0,TP,1005	
2203-000425	C202	C-CERAMIC,CHIP	0.018nF,5%,50V,NP0,TP,1005	
2203-000438	C151	C-CERAMIC,CHIP	1nF,10%,50V,X7R,TP,1005,-	
2203-000438	C174	C-CERAMIC,CHIP	1nF,10%,50V,X7R,TP,1005,-	
2203-000438	C176	C-CERAMIC,CHIP	1nF,10%,50V,X7R,TP,1005,-	
2203-000438	C177	C-CERAMIC,CHIP	1nF,10%,50V,X7R,TP,1005,-	
2203-000438	C178	C-CERAMIC,CHIP	1nF,10%,50V,X7R,TP,1005,-	
2203-000438	C180	C-CERAMIC,CHIP	1nF,10%,50V,X7R,TP,1005,-	
2203-000438	C204	C-CERAMIC,CHIP	1nF,10%,50V,X7R,TP,1005,-	
2203-000438	C206	C-CERAMIC,CHIP	1nF,10%,50V,X7R,TP,1005,-	
2203-000438	C210	C-CERAMIC,CHIP	1nF,10%,50V,X7R,TP,1005,-	
2203-000438	C212	C-CERAMIC,CHIP	1nF,10%,50V,X7R,TP,1005,-	
2203-000438	C214	C-CERAMIC,CHIP	1nF,10%,50V,X7R,TP,1005,-	
2203-000438	C216	C-CERAMIC,CHIP	1nF,10%,50V,X7R,TP,1005,-	
2203-000438	C218	C-CERAMIC,CHIP	1nF,10%,50V,X7R,TP,1005,-	
2203-000438	C220	C-CERAMIC,CHIP	1nF,10%,50V,X7R,TP,1005,-	
2203-000438	C222	C-CERAMIC,CHIP	1nF,10%,50V,X7R,TP,1005,-	
2203-000438	C224	C-CERAMIC,CHIP	1nF,10%,50V,X7R,TP,1005,-	
2203-000438	C226	C-CERAMIC,CHIP	1nF,10%,50V,X7R,TP,1005,-	
2203-000438	C227	C-CERAMIC,CHIP	1nF,10%,50V,X7R,TP,1005,-	
2203-000438	C233	C-CERAMIC,CHIP	1nF,10%,50V,X7R,TP,1005,-	
2203-000438	C235	C-CERAMIC,CHIP	1nF,10%,50V,X7R,TP,1005,-	
2203-000438	C237	C-CERAMIC,CHIP	1nF,10%,50V,X7R,TP,1005,-	
2203-000438	C238	C-CERAMIC,CHIP	1nF,10%,50V,X7R,TP,1005,-	
2203-000438	C239	C-CERAMIC,CHIP	1nF,10%,50V,X7R,TP,1005,-	
2203-000438	C265	C-CERAMIC,CHIP	1nF,10%,50V,X7R,TP,1005,-	
2203-000438	C299	C-CERAMIC,CHIP	1nF,10%,50V,X7R,TP,1005,-	
2203-000489	C236	C-CERAMIC,CHIP	2.2nF,10%,50V,X7R,TP,1005,-	
2203-000679	C143	C-CERAMIC,CHIP	0.027nF,5%,50V,NP0,TP,1005	
2203-000679	C144	C-CERAMIC,CHIP	0.027nF,5%,50V,NP0,TP,1005	
2203-000836	C243	C-CERAMIC,CHIP	390pF,10%,50V,X7R,TP,1005,-	
2203-000885	C228	C-CERAMIC,CHIP	4.7nF,10%,25V,X7R,TP,1005,-	
2203-000885	C229	C-CERAMIC,CHIP	4.7nF,10%,25V,X7R,TP,1005,-	
2203-000940	C121	C-CERAMIC,CHIP	470pF,10%,50V,X7R,TP,1005,-	
2203-000940	C122	C-CERAMIC,CHIP	470pF,10%,50V,X7R,TP,1005,-	
2203-000940	C129	C-CERAMIC,CHIP	470pF,10%,50V,X7R,TP,1005,-	
2203-001124	C255	C-CERAMIC,CHIP	680pF,10%,50V,X7R,TP,1005,-	
2203-001178	C242	C-CERAMIC,CHIP	0.006nF,0.5pF,50V,NP0,TP,1005	
2203-001210	C123	C-CERAMIC,CHIP	8.2nF,10%,16V,X7R,TP,1005,-	
2203-001210	C124	C-CERAMIC,CHIP	8.2nF,10%,16V,X7R,TP,1005,-	
2203-001210	C125	C-CERAMIC,CHIP	8.2nF,10%,16V,X7R,TP,1005,-	
2203-001210	C126	C-CERAMIC,CHIP	8.2nF,10%,16V,X7R,TP,1005,-	
2203-001416	C112	C-CERAMIC,CHIP	33nF,10%,16V,Y5V,TP,1005,1.0mm	
2203-001432	C110	C-CERAMIC,CHIP	47nF,10%,16V,Y5V,TP,1005	
2203-001432	C248	C-CERAMIC,CHIP	47nF,10%,16V,Y5V,TP,1005	
2203-001724	C157	C-CERAMIC,CHIP	4700NF,+80-20%,16V,Y5V,TP,3216	
2203-001724	C160	C-CERAMIC,CHIP	4700NF,+80-20%,16V,Y5V,TP,3216	
2203-001724	C161	C-CERAMIC,CHIP	4700NF,+80-20%,16V,Y5V,TP,3216	

SEC CODE	LOC NO.	DESCRIPTION	SPEC	REMARK
2203-002494	C251	C-CERAMIC,CHIP	470nF,10%,16V,X7R,TP,2012	
2203-002525	C184	C-CERAMIC,CHIP	0.56nF,10%,50V,X7R,TP,1005	
2203-002525	C185	C-CERAMIC,CHIP	0.56nF,10%,50V,X7R,TP,1005	
2203-002525	C186	C-CERAMIC,CHIP	0.56nF,10%,50V,X7R,TP,1005	
2203-002525	C187	C-CERAMIC,CHIP	0.56nF,10%,50V,X7R,TP,1005	
2203-005061	C102	C-CERAMIC,CHIP	100nF,+80-20%,16V,Y5V,TP,1005	
2203-005061	C104	C-CERAMIC,CHIP	100nF,+80-20%,16V,Y5V,TP,1005	
2203-005061	C106	C-CERAMIC,CHIP	100nF,+80-20%,16V,Y5V,TP,1005	
2203-005061	C113	C-CERAMIC,CHIP	100nF,+80-20%,16V,Y5V,TP,1005	
2203-005061	C119	C-CERAMIC,CHIP	100nF,+80-20%,16V,Y5V,TP,1005	
2203-005061	C132	C-CERAMIC,CHIP	100nF,+80-20%,16V,Y5V,TP,1005	
2203-005061	C133	C-CERAMIC,CHIP	100nF,+80-20%,16V,Y5V,TP,1005	
2203-005061	C155	C-CERAMIC,CHIP	100nF,+80-20%,16V,Y5V,TP,1005	
2203-005061	C245	C-CERAMIC,CHIP	100nF,+80-20%,16V,Y5V,TP,1005	
2203-005061	C246	C-CERAMIC,CHIP	100nF,+80-20%,16V,Y5V,TP,1005	
2203-005061	C254	C-CERAMIC,CHIP	100nF,+80-20%,16V,Y5V,TP,1005	
2203-005061	C256	C-CERAMIC,CHIP	100nF,+80-20%,16V,Y5V,TP,1005	
2203-005061	C259	C-CERAMIC,CHIP	100nF,+80-20%,16V,Y5V,TP,1005	
2203-005061	C266	C-CERAMIC,CHIP	100nF,+80-20%,16V,Y5V,TP,1005	
2203-005061	C267	C-CERAMIC,CHIP	100nF,+80-20%,16V,Y5V,TP,1005	
2203-005061	C269	C-CERAMIC,CHIP	100nF,+80-20%,16V,Y5V,TP,1005	
2203-005061	C273	C-CERAMIC,CHIP	100nF,+80-20%,16V,Y5V,TP,1005	
2203-005061	C301	C-CERAMIC,CHIP	100nF,+80-20%,16V,Y5V,TP,1005	
2203-005065	C156	C-CERAMIC,CHIP	1000nF,+80-20%,10V,Y5V,TP,1608	
2203-005065	C159	C-CERAMIC,CHIP	1000nF,+80-20%,10V,Y5V,TP,1608	
2203-005065	C168	C-CERAMIC,CHIP	1000nF,+80-20%,10V,Y5V,TP,1608	
2203-005138	C270	C-CERAMIC,CHIP	1.8nF,10%,50V,X7R,TP,1005,-	
2203-005138	C271	C-CERAMIC,CHIP	1.8nF,10%,50V,X7R,TP,1005,-	
2203-005138	C272	C-CERAMIC,CHIP	1.8nF,10%,50V,X7R,TP,1005,-	
2203-005496	C208	C-CERAMIC,CHIP	220nF,+80-20%,10V,Y5V,TP,1005	
2203-005496	C230	C-CERAMIC,CHIP	220nF,+80-20%,10V,Y5V,TP,1005	
2404-001017	C131	C-TA,CHIP	1uF,20%,10V,GP,TP,2012,2,0	
2404-001086	C162	C-TA,CHIP	4.7uF,20%,6.3V,GP,TP,2012,-	
2404-001088	C153	C-TA,CHIP	2.2uF,20%,6.3V,GP,TP,2012,-	
2404-001088	C241	C-TA,CHIP	2.2uF,20%,6.3V,GP,TP,2012,-	
2404-001088	C252	C-TA,CHIP	2.2uF,20%,6.3V,GP,TP,2012,-	
2404-001088	C264	C-TA,CHIP	2.2uF,20%,6.3V,GP,TP,2012,-	
2404-001100	C150	C-TA,CHIP	33uF,20%,6.3V,GP,TP,3719,-	
2404-001100	C257	C-TA,CHIP	33uF,20%,6.3V,GP,TP,3719,-	
2703-000300	L203	INDUCTOR-SMD	1uH,10%,0.8x1.6x0.8mm	
2703-000300	L211	INDUCTOR-SMD	1uH,10%,0.8x1.6x0.8mm	
2703-001231	L204	INDUCTOR-SMD	10uH,10%,1.6x0.8x0.8mm	
2703-001512	L208	INDUCTOR-SMD	27nH,5%,1.8x1.12x1.02mm	
2703-001914	L205	INDUCTOR-SMD	180nH,2%,1.6x0.8x0.8mm	
2703-001914	L207	INDUCTOR-SMD	180nH,2%,1.6x0.8x0.8mm	
2703-001926	L206	INDUCTOR-SMD	27nH,2%,1.6x0.8x0.8mm	
2801-003747	OSC102	CRYSTAL-SMD	.032768MHZ,30PPM,28-ACM,9PF	
2802-001104	OSC101	RESONATOR-CERAMIC	27MHZ,0.5%,TP,2.5X2X1.2	
3002-001094	AU101	BUZZER-MAGNETIC	93dB,3.6V,90mA,2630Hz,TP	

SEC CODE	LOC NO.	DESCRIPTION	SPEC	REMARK
3301-001105	L201	CORE-FERRITE	AB,1.6x0.8x0.8mm,-,-	
3301-001105	L202	CORE-FERRITE	AB,1.6x0.8x0.8mm,-,-	
3301-001105	L209	CORE-FERRITE	AB,1.6x0.8x0.8mm,-,-	
3301-001105	L210	CORE-FERRITE	AB,1.6x0.8x0.8mm,-,-	
3301-001105	L212	CORE-FERRITE	AB,1.6x0.8x0.8mm,-,-	
3708-001295	CN400	CONNECTOR-FPC/FC/PIC	22P,0.5mm,SMD-A,SN	
3710-001510	J401	CONNECTOR-SOCKET	18P,1R,0.5MM,SMD-A,AUF	
3711-004367	CN401	CONNECTOR-HEADER	BOX,40P,2R,0.5MM,SMD-S,AUF	
3722-001172	J200	JACK-AC POWER	2P,2.6PI,AU,BLK,NO	
GH71-00002A	GD101	NPR-GROUNDING TERMINAL	SCH-510,C1720,T0.1,-	
GH71-00002A	GD102	NPR-GROUNDING TERMINAL	SCH-510,C1720,T0.1,-	
GH71-00002A	GD103	NPR-GROUNDING TERMINAL	SCH-510,C1720,T0.1,-	
GH71-00002A	GD104	NPR-GROUNDING TERMINAL	SCH-510,C1720,T0.1,-	
GH71-00002A	GD105	NPR-GROUNDING TERMINAL	SCH-510,C1720,T0.1,-	
GH71-00002A	GD106	NPR-GROUNDING TERMINAL	SCH-510,C1720,T0.1,-	
GH71-00002A	GD107	NPR-GROUNDING TERMINAL	SCH-510,C1720,T0.1,-	
GH71-00002A	GD108	NPR-GROUNDING TERMINAL	SCH-510,C1720,T0.1,-	
GH71-00002A	GD109	NPR-GROUNDING TERMINAL	SCH-510,C1720,T0.1,-	
GH71-00002A	GD110	NPR-GROUNDING TERMINAL	SCH-510,C1720,T0.1,-	
GH71-00002A	GD111	NPR-GROUNDING TERMINAL	SCH-510,C1720,T0.1,-	
GH71-00002A	GD112	NPR-GROUNDING TERMINAL	SCH-510,C1720,T0.1,-	

7. Block Diagram

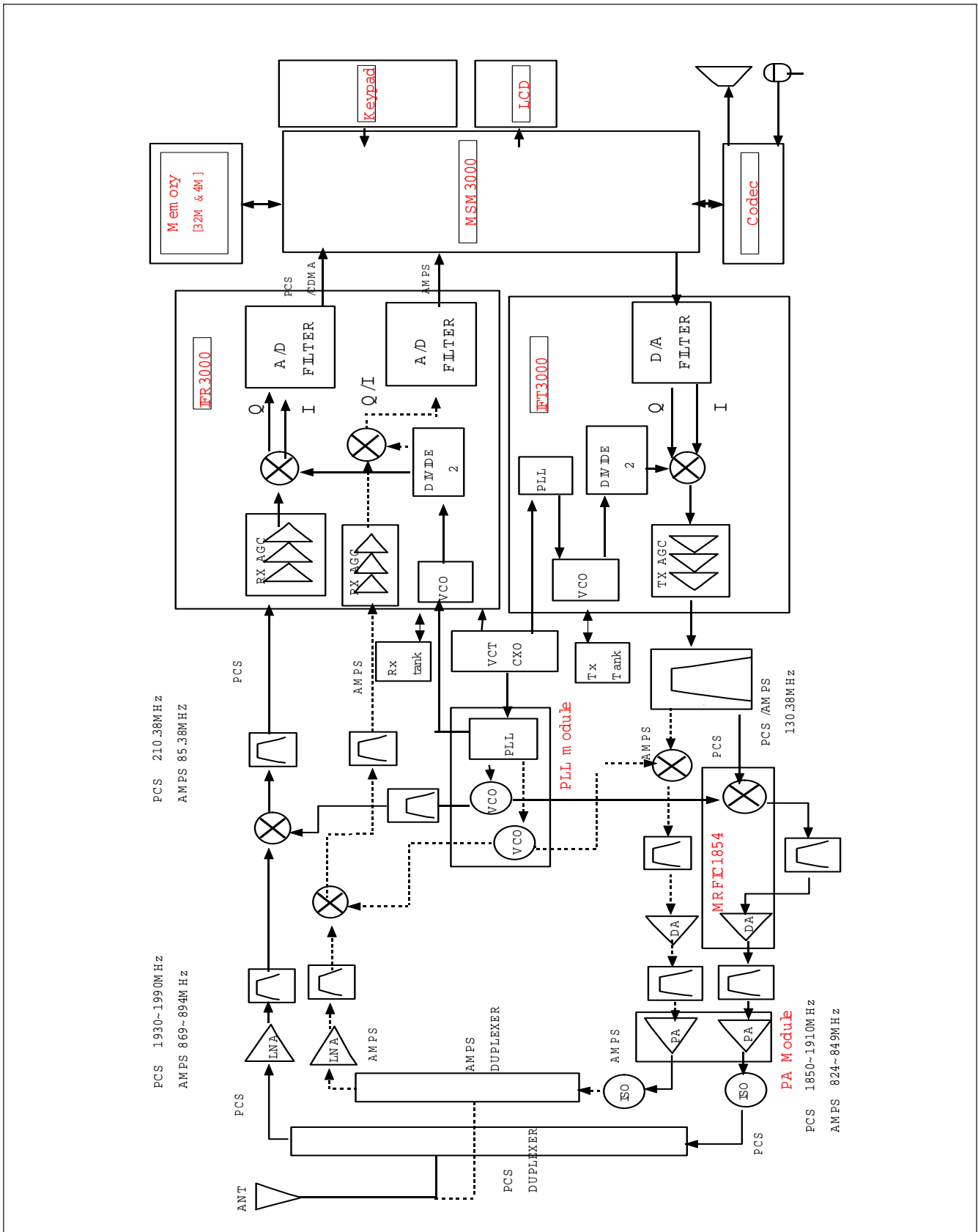

8. PCB Diagram

8-1 Logic Top View

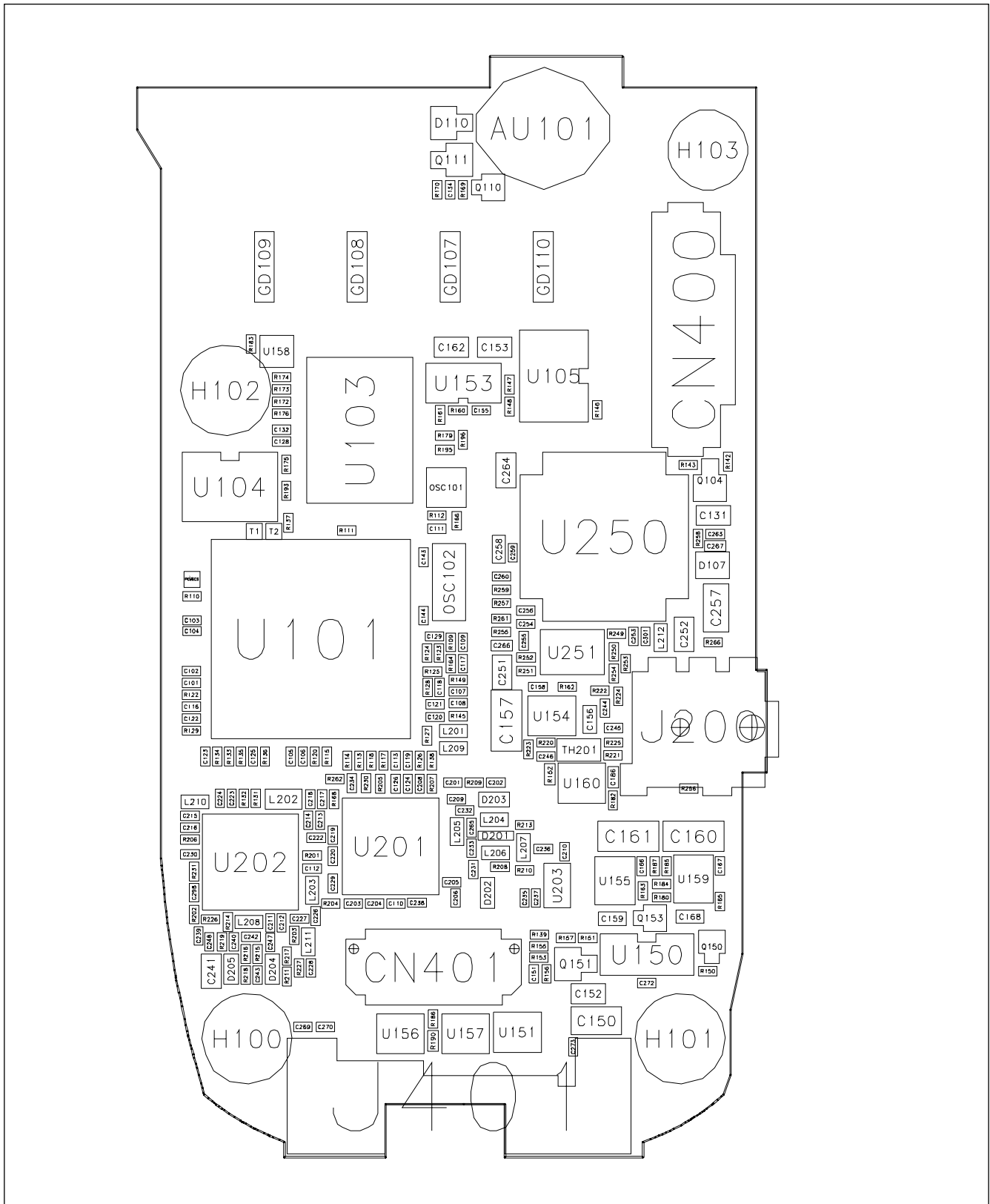

8-2 Logic Bottom View

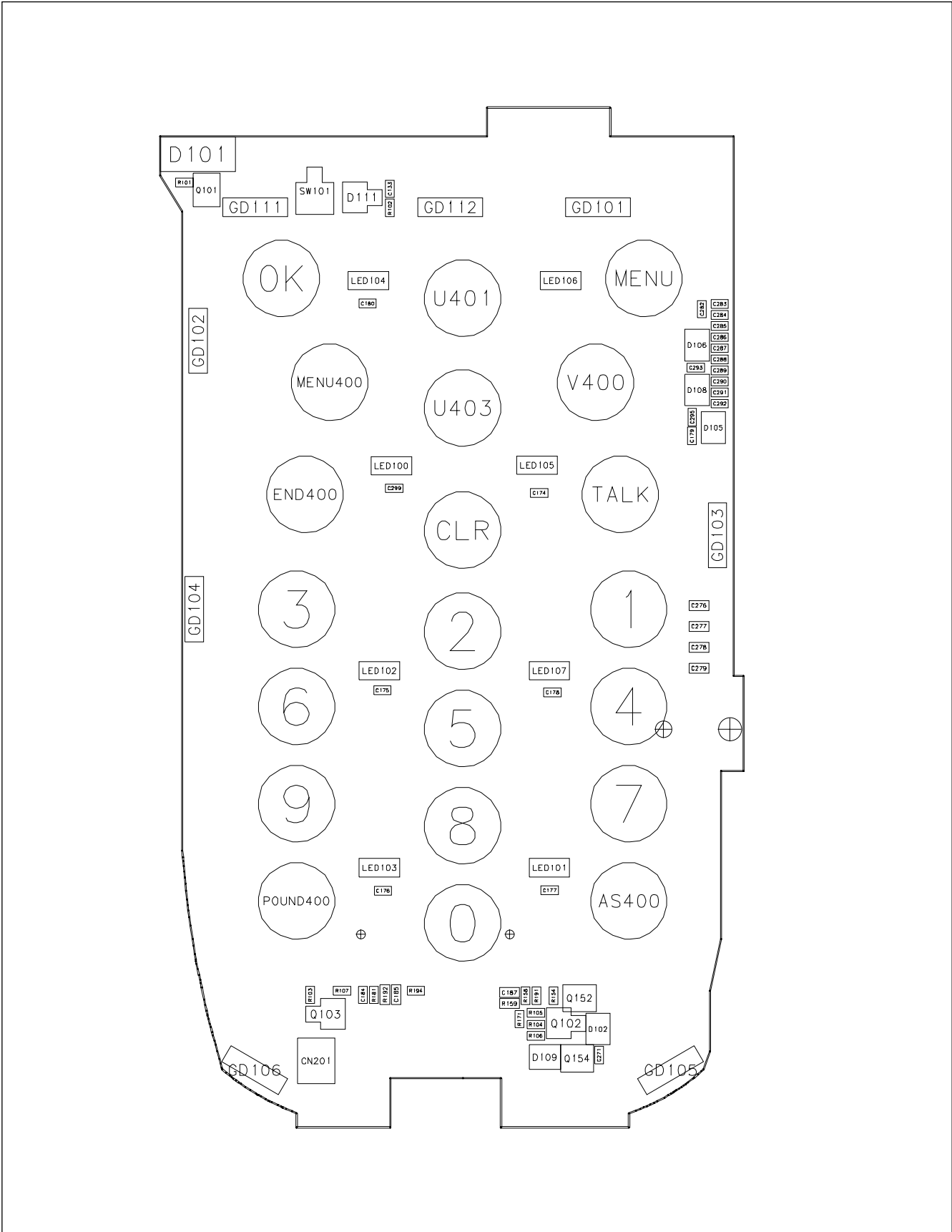

8-3 RF Bottom View

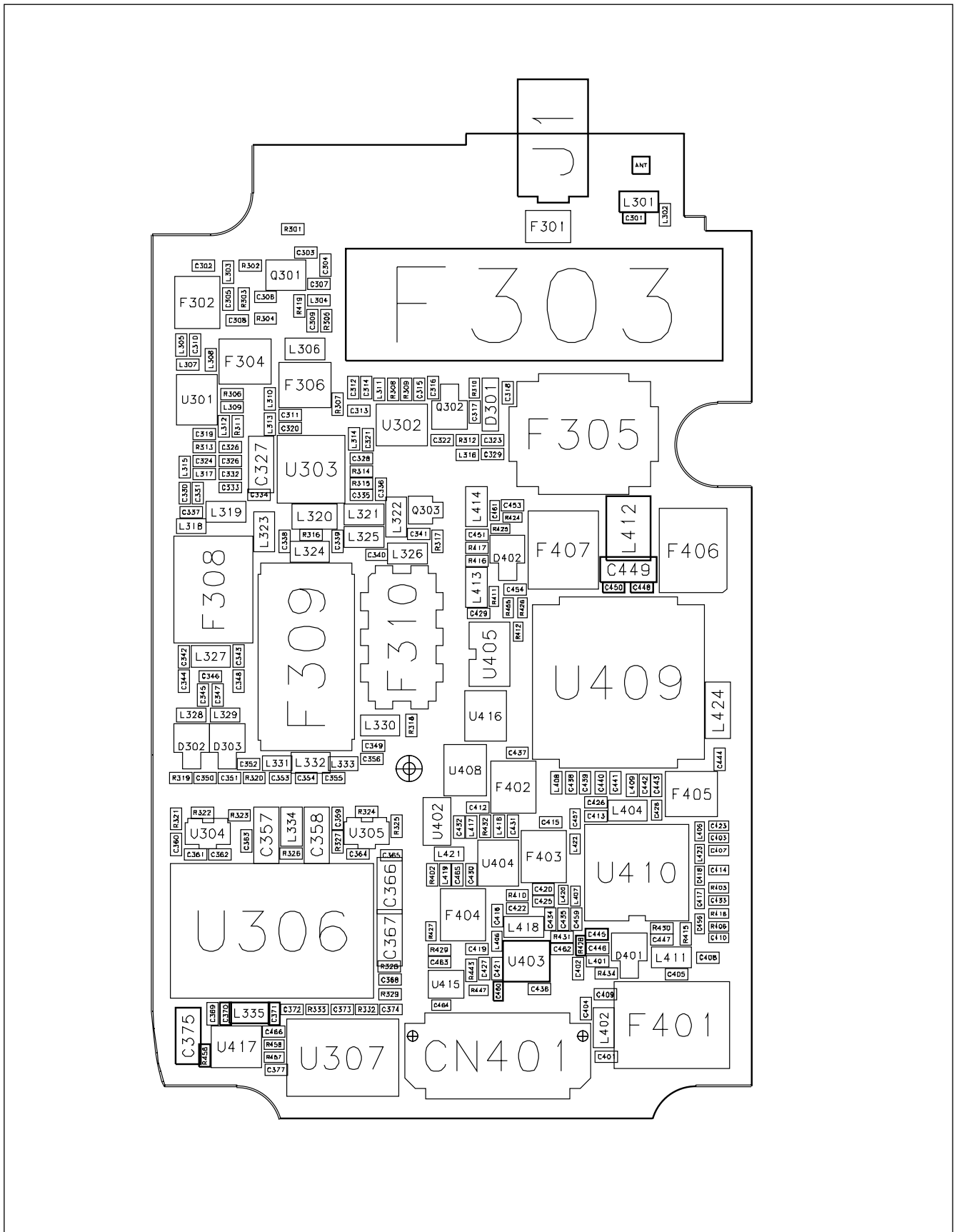

9. Schematic Diagrams

9-1 Logic Circuit Diagram (1)

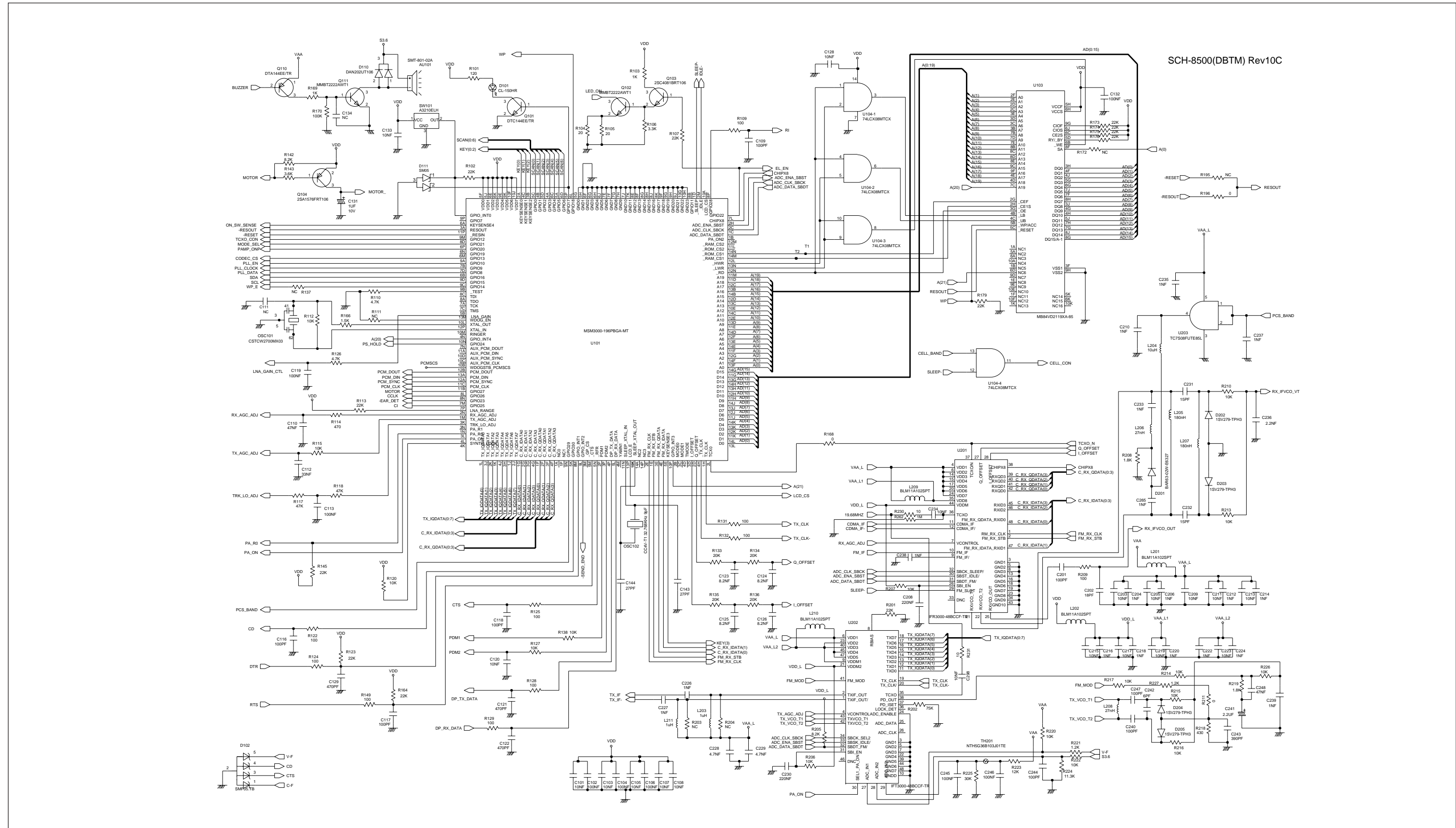

9-2 Logic Circuit Diagram (2)

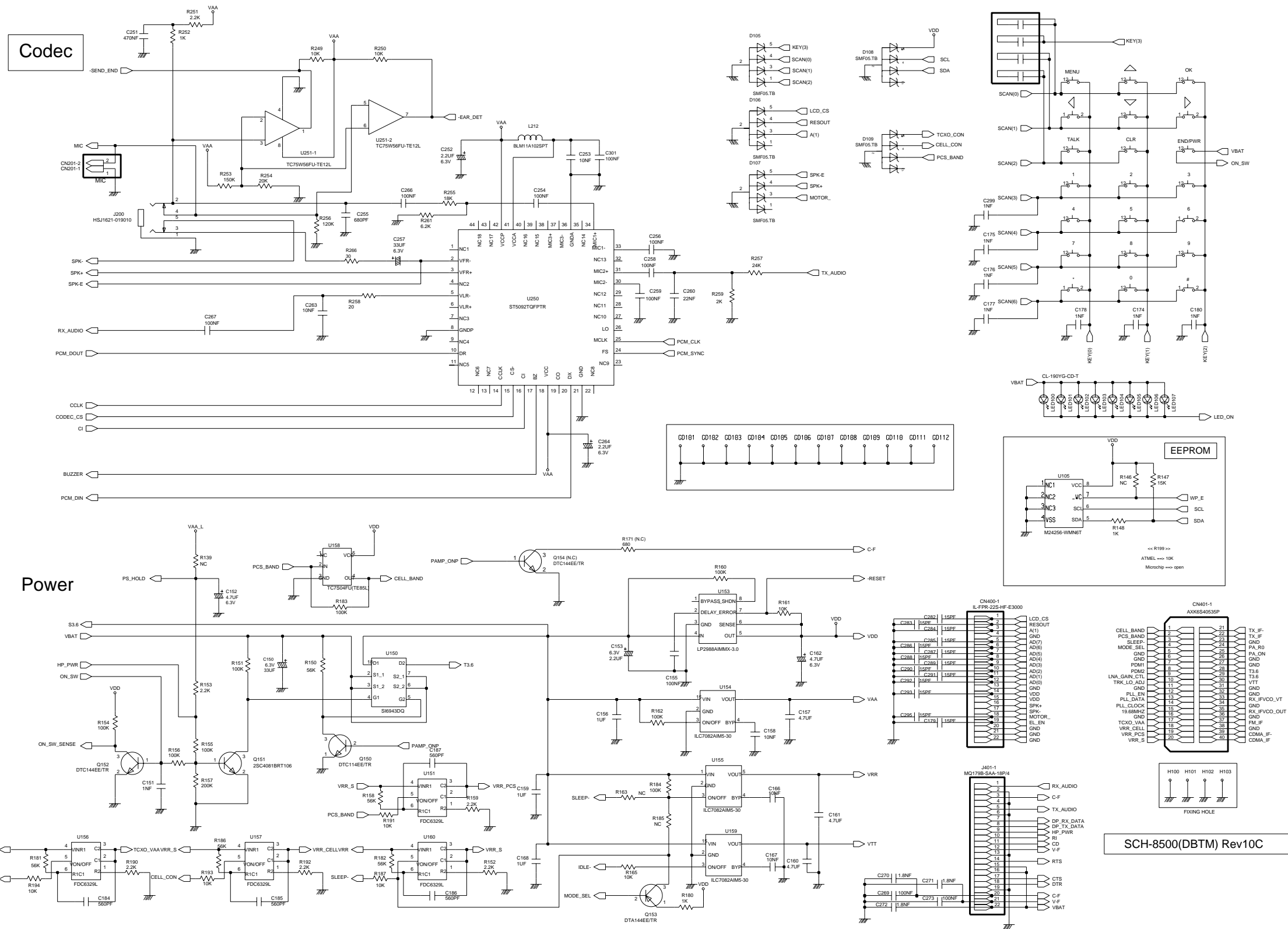

9-3 Transmitter Circuit Diagram

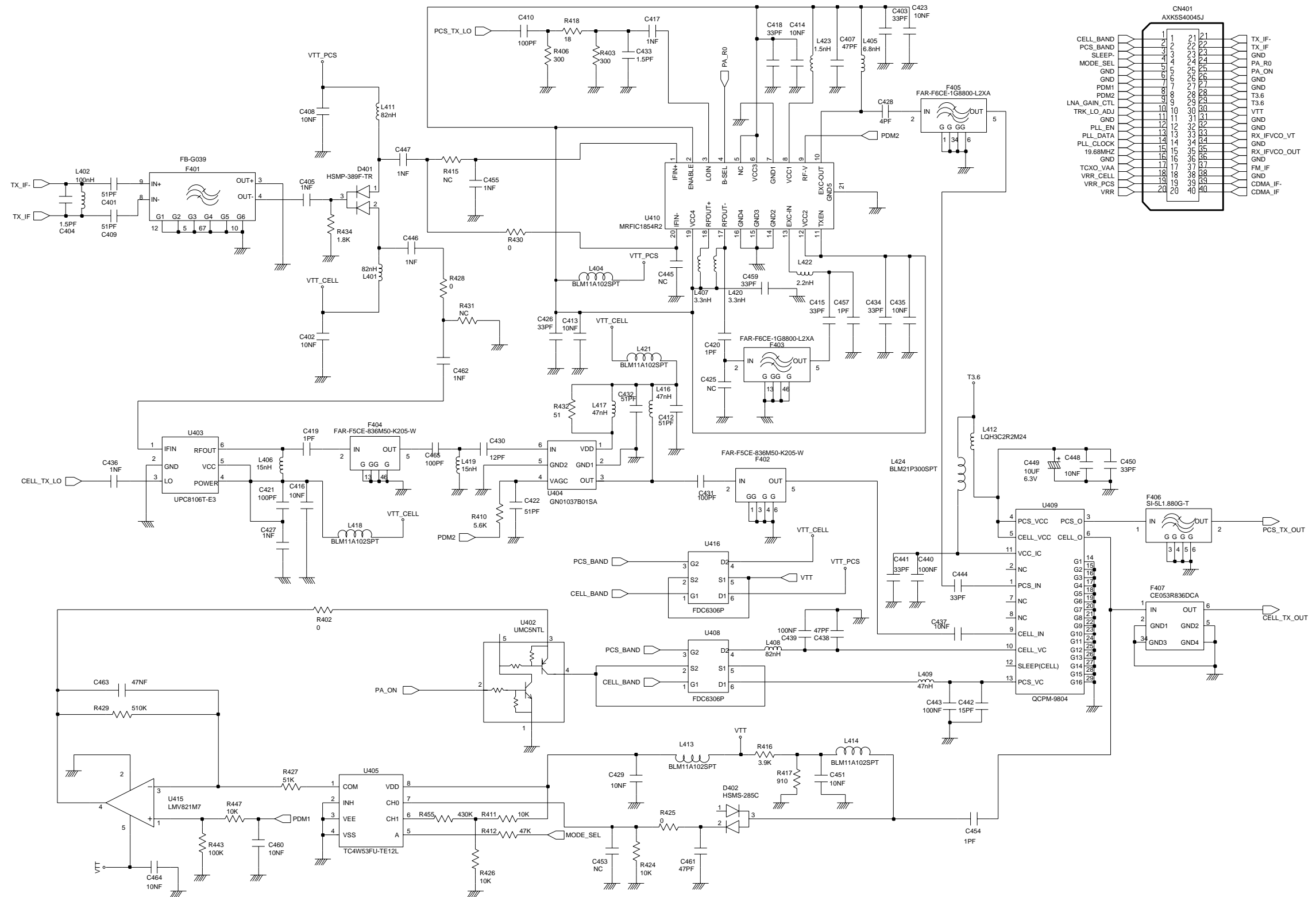

9-4 Receiver Circuit Diagram

