

SURFACE-MOUNT TOROIDAL COMMON MODE CHOKES

STR1206-0603 SERIES



FEATURES:

- SMD Housing
- High Frequency Design
- Excellent Mechanical Strength
- Excellent Solderability
- High Reliability
- Low Profile

OPTIONS:

- Packaging: Tape & Reel is standard (Qty: 2000pcs)
- Bulk packaging available for smaller quantities
- Tolerance: 10% and 5% is standard, tighter tolerances available

COMMON APPLICATIONS:

- VCRs
- Video Cameras
- Communication System
- Automotive Systems
- Liquid Crystal Televisions
- Hard Disk Drives
- Network Systems
- Computer Peripheral Equipment

ELECTRICAL CHARACTERISTICS

MSN: bruce_fu-vip@hotmail.com

Part Number	L mH	Test Freq KHz	DCR Max	IDC A Max	Part Number	L H	Test Freq KHz	DCR Max	IDC A Max
STR1206-123Y	12.0	1	1.15	0.3	TR1206-123Y	12.0	1	1.15	0.3
STR1206-442Y	4.4	1	0.43	0.6	TR1206-442Y	4.4	1	0.43	0.6
STR1206-302Y	3.0	1	0.23	1.0	TR1206-302Y	3.0	1	0.23	1.0
STR1206-112Y	1.1	1	0.07	2.0	TR1206-112Y	1.1	1	0.07	2.0
STR0603-102Y	1.0	1	0.82	0.5					
STR0603-501Y	0.5	1	0.45	0.6					
STR0603-221Y	0.22	1	0.22	0.8					
STR0603-151Y	0.15	1	0.15	1.0					

Note: Y Min

TECHNICAL INFORMATION: PHYSICAL CHARACTERISTICS:

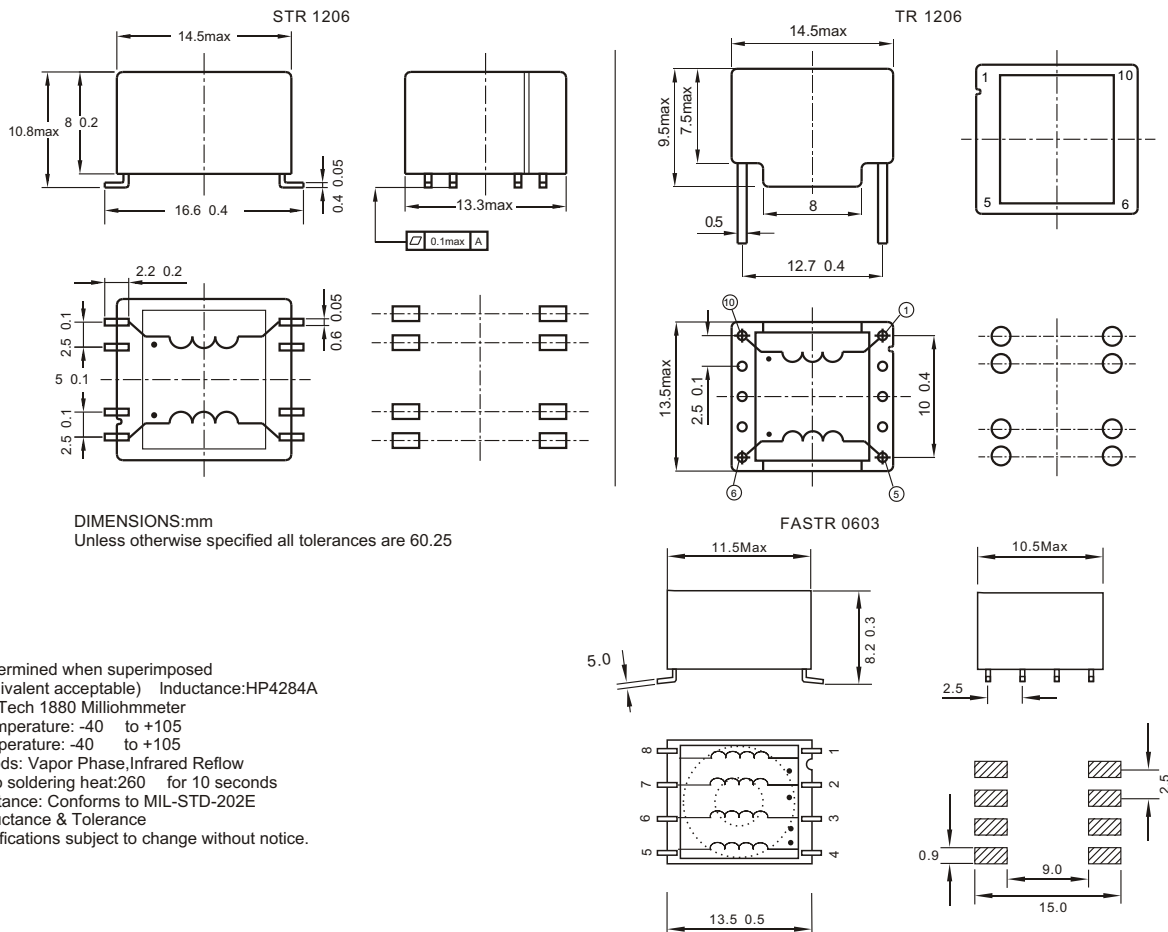

DIMENSIONS:mm
Unless otherwise specified all tolerances are 60.25

IDC Max:Determined when superimposed
Testing: (Equivalent acceptable) Inductance:HP4284A
RDC:QuadTech 1880 Milliohm-meter
Operating temperature: -40 to +105
Storage Temperature: -40 to +105
Solder methods: Vapor Phase, Infrared Reflow
Resistance to soldering heat: 260 for 10 seconds
Solvent resistance: Conforms to MIL-STD-202E
Marking: Inductance & Tolerance
Note: All specifications subject to change without notice.