

TDS1I2C1

Features

- Mini I²C Board
- Microchip MCP79410 Real Time Clock with additional 64 bytes of SRAM and 1Kbit EEPROM.
- Battery Backup of MCP79410 RTCC and SRAM with included CR1220 lithium cell.
- 24AA512 EEPROM memory with 64Kbytes of non-volatile storage.
- TCN75 temperature sensor.
- Wide operating voltage 2.7v - 5.5v. Temperature sensor optimised for 3.3v.
- Small 24 pin IC compatible package 0.1"x0.9" pitch.
- Selectable on-board I2C 2K2 pull-ups.
- RTCC and Temperature sensor interrupt outputs with resistor pull-ups.
- Overall size 28mm(w) x 34mm(l).
- MPASM and MC18 USB CDC Serial Demo code provided showing full use of the I2c peripherals.
- Pin Compatible with TDSDB146J50.

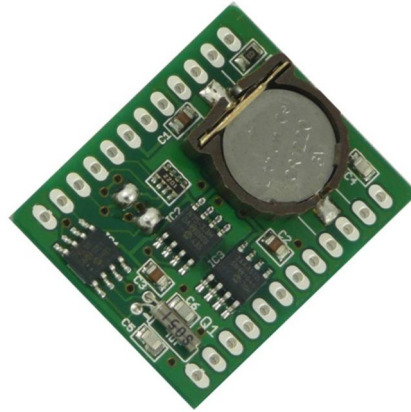

Description

The Tiertex I2C Add-on board is a combination of 3 useful I2c devices in a compact package. The board incorporates battery backed real time clock, large EEPROM non-volatile memory and temperature sensor.

Contents

| | |
|---|---|
| 1.0 Pin Diagram | 3 |
| 1.1 Electrical Characteristics | 3 |
| 1.2 I ² C Address Table | 3 |
| 2.0 On-Board Features..... | 4 |
| 2.1 MCP79410 Real Time Clock..... | 4 |
| 2.2 TCN75 MOA Temperature Sensor | 5 |
| 2.3 24AA512 512Kbit EEPROM..... | 5 |
| 2.4 I ² C Pull-up resistors..... | 5 |
| 3.0 Data Sheet References..... | 6 |
| 4.0 Schematic..... | 7 |
| 5.0 Example PIC18F C software..... | 7 |

1.0 Pin Diagram

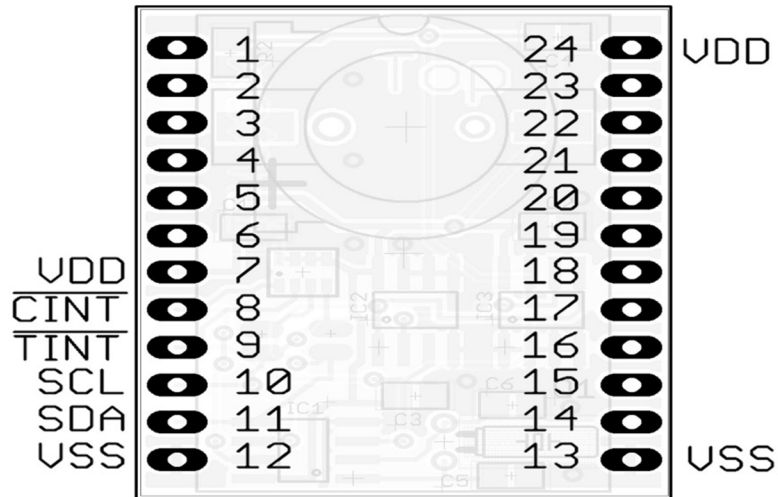

Figure 1

Dimensions 28mm (w) x 34mm (h).

1.1 Electrical Characteristics

Operating conditions at 25°C

| Parameter | Min | Typ. | Max | Units |
|---------------------|-----|------|-----|-------|
| Supply voltage | 2.7 | 3.3 | 5.5 | V |
| Current Requirement | | | 6.0 | ma |

Figure 2 Electrical Characteristics

1.2 I²C Address Table

| Device | Description | Read Address | Write Address |
|---------------|--------------------|--------------|---------------|
| MCP79410 RTCC | Real Time Clock | 0xdf | 0xde |
| TCN75 | Temperature Sensor | 0x91 | 0x90 |
| 24AA512 | 512Kbit EEPROM | 0xa1 | 0xa0 |

Figure 3

Additional TCN75s and 24AA512s can be added to the I²C bus as long as their chip address a0-a2 are not set to 0.

2.0 On-Board Features

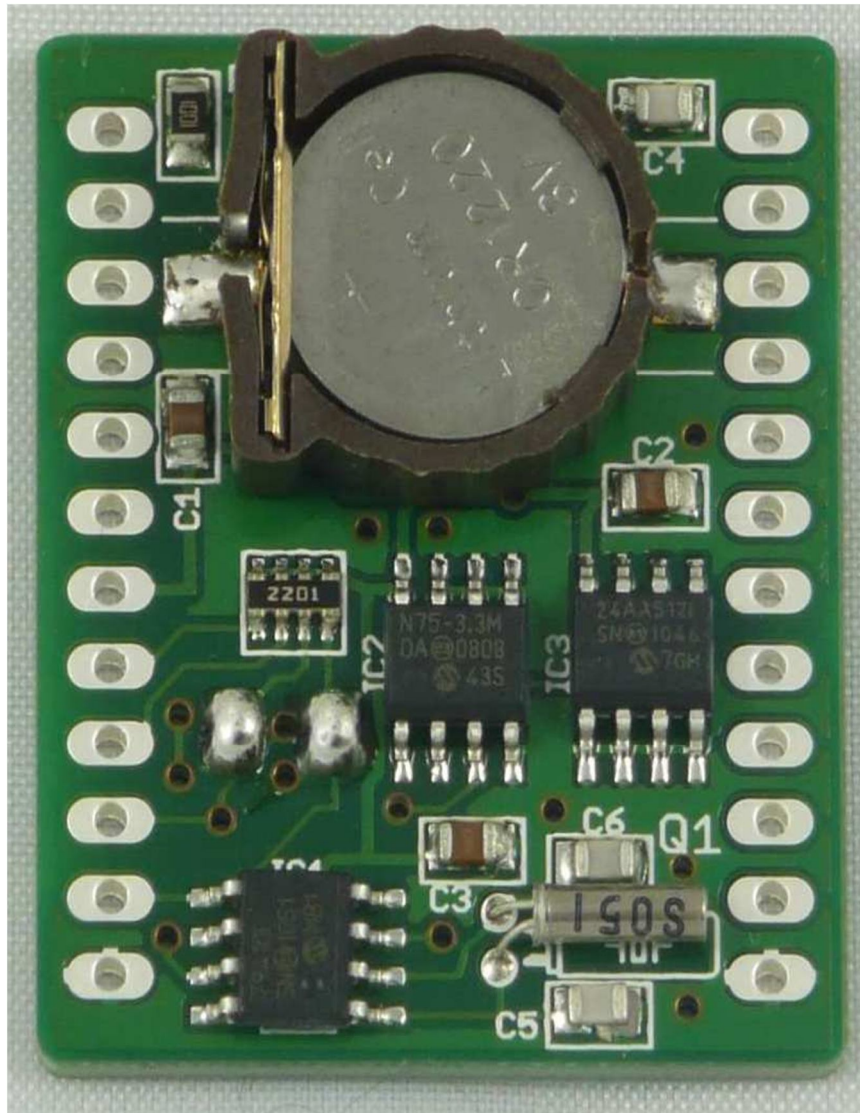

2.1 MCP79410 Real Time Clock

Microchip's MCP79410 RTCC implementation includes the following features

- Full on chip RTCC with on board battery backup.
- Dual Alarm with interrupt out.
- Shut down and start up time stamps.
- 64 bytes of battery backed SRAM
- 1024 Kbits of non-volatile EEPROM
- Programmable square wave output

- Digital calibration adjustment

The battery backup utilises a CR1220 lithium coin cell (included).

Pin 8, CINT is connected to the MCP79410 multifunction output pin and has a 2K2 Ω pull-up resistor.

2.2 TCN75 MOA Temperature Sensor

Microchip's TCN75 temperature sensor has the following features

- -55°C to 125°C range to 0.5°C resolution.
- Maximum 8 addressable devices on same bus.
- Programmable output pin, temperature alarm interrupt, comparator/thermostat output.
- Programmable trip points with hysteresis.
- Low power. 250 μ a typical.

Pin 9, TINT is connected to the TCN75 multifunction output pin and has a 2K2 Ω pull-up resistor.

2.3 24AA512 512Kbit EEPROM

- The on-board 24AA512 512Kbit EEPROM has 64Kbytes of non-volatile memory.
- Low power, 400 μ a typical.
- 128 byte write buffer.
- Fully automatic erase and write cycle.
- Maximum 8 addressable devices on same bus.
- 1 million write/erase cycles, >200 year data retention life.

2.4 I²C Pull-up resistors

The board has $2K2\Omega$ pull-up resistors on both the SCL and SDA open collector I²C lines, these values are required for 400 KHz I²C communication at 3.3v. If you do not require pull-up resistors then there are some de-solderable links on the board to disconnect this feature.

3.0 Data Sheet References

Full data sheets at www.microchip.com

MCP79410 Real Time Clock

<http://ww1.microchip.com/downloads/en/DeviceDoc/22266A.pdf>

TCN75 MOA Temperature Sensor

<http://ww1.microchip.com/downloads/en/DeviceDoc/21935D.pdf>

24AA512 512Kbit EEPROM

<http://ww1.microchip.com/downloads/en/DeviceDoc/21754M.pdf>

4.0 Schematic

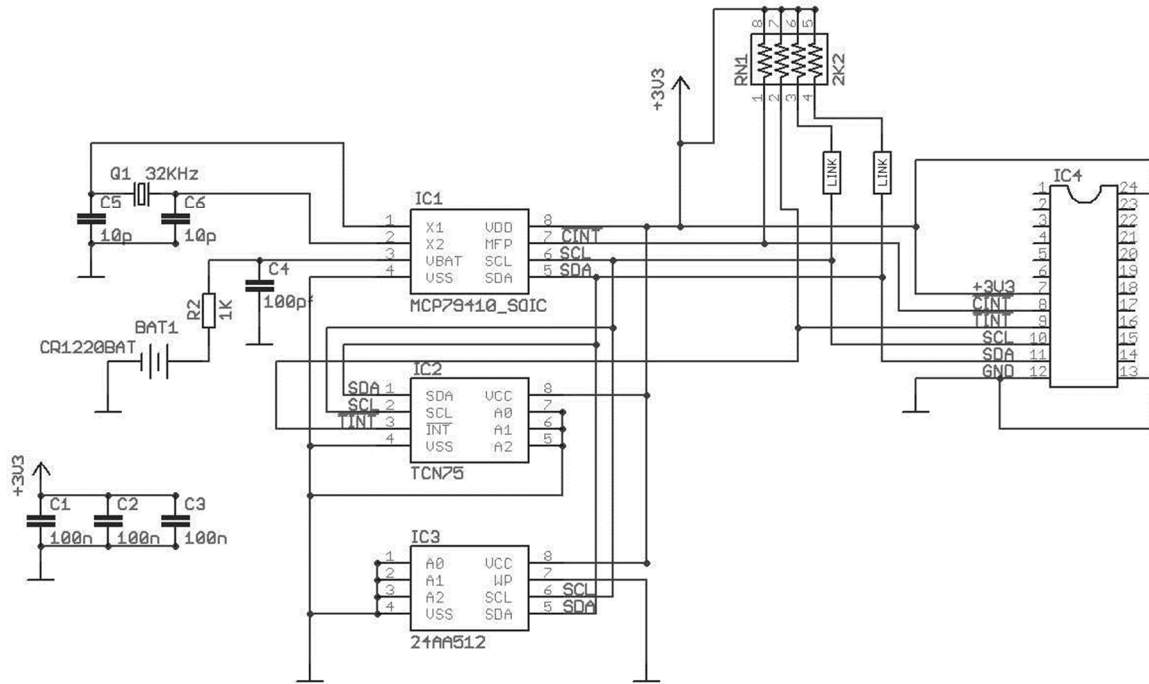

Figure 4

5.0 Example PIC18F C software

```
// Example Code for a I2c implementation on Microchip PIC18F46J50
// You are free to use as you wish, but it is supplied 'as is'
// Tiertex Design Studios shall not be liable in any circumstances for any damages arising
// when using this code.

// The code below uses simple software polling techniques for I2C communication. For more efficient
// code use interrupt polling instead.
// This code is not intended to compile as is but is a collection of routines taken from the USB
// CDCSerial Demo for the I2C add-card based on the Tiertex PIC18F46J50 demo board.
// The full project can be downloaded from www.tiertex.com

#define SCLK1          PORTBbits.SCL1
#define SDAT1         PORTBbits.SDA1
char  RTCCDATA[32]; // 32 byte copy of the rtcc registers
char  RTCCSRAM[64]; // 64 byte copy of rtcc sram
char  t7;

// Set up PIC's I2C module
//
void InitI2C()
{
    SCLK1 = 0;
    SDAT1 = 0;
}
```

```
    SSPSTAT = 0;           // disable SMBUS
    SSPSTATbits.SMP = 1;   // disable slew rate
    SSPADD = 0x18*4;       // 100kz I2C comms.
    SSPCON1bits.SSPM3 = 1; // I2C master mode in hardware
    SSPCON1bits.SSPEN = 1; // enable SSP module
    SSPCON2 = 0;           // clear MSSP
    PIR1bits.SSPIF = 0;    // Clear SSP interrupt flag
    PIR2bits.BCLIF = 0;    // Clear Bit Collision flag
}

// Send a START command
//
void Start()
{
    PIR1bits.SSPIF = 0;    // Clear SSP interrupt flag
    SSPCON2bits.SEN = 1;   // Generate Start condition
    while ( PIR1bits.SSPIF == 0 ) {}
}

// A RESTART for multiple I2c commands
//
void Restart()
{
    PIR1bits.SSPIF = 0;    // Clear SSP interrupt flag
    SSPCON2bits.RSEN = 1;  // Generate Restart condition
    while ( PIR1bits.SSPIF == 0 ) {}
}

// STOP I2c command
//
void Stop()
{
    PIR1bits.SSPIF = 0;    // Clear SSP interrupt flag
    SSPCON2bits.PEN = 1;   // Generate Stop condition
    while ( PIR1bits.SSPIF == 0 ) {}
}

// Send a byte on the I2C bus
//
void TXbyte(BYTE a)
{
    PIR1bits.SSPIF = 0;    // Clear SSP interrupt flag
    SSPBUF = a;            // Write byte out to device
    while ( PIR1bits.SSPIF == 0 ) {}
}

// Read byte from the I2C bus
//
BYTE RXbyte()
{
    SSPCON2bits.ACKDT = 0; // No Ack as this is one of many reads
    PIR1bits.SSPIF = 0;    // Clear SSP interrupt flag
    SSPCON2bits.RCEN = 1;  // Initiate reception of byte
    while ( PIR1bits.SSPIF == 0 ) {} // wait till reception

    PIR1bits.SSPIF = 0;    // Clear SSP interrupt flag
    SSPCON2bits.ACKEN = 1; // Generate ACK/NO ACK bit
    while ( PIR1bits.SSPIF == 0 ) {} // wait till complete
    return SSPBUF;
}

// Read the last byte of a read sequence from the I2C bus, the ack lets the I2c slave that this is the
// last requested byte
//
BYTE RXbyteACK()
{
    SSPCON2bits.ACKDT = 1; // Ack as this is the last read
    PIR1bits.SSPIF = 0;    // Clear SSP interrupt flag
    SSPCON2bits.RCEN = 1;  // Initiate reception of byte
}
```



```

while ( PIR1bits.SSPIF == 0 ) {} // wait till reception
PIR1bits.SSPIF = 0;           // Clear SSP interrupt flag
SSPCON2bits.ACKEN = 1;       // Generate ACK/NO ACK bit
while ( PIR1bits.SSPIF == 0 ) {} // wait till complete
return SSPBUF;
}

void ReadI2Crtcc()
{
    Start();                // start I2C exchange
    TXbyte(0xde);           // send write address to RTCC
    TXbyte(0x00);           // set ptr to 0
    Restart();
    TXbyte(0xdf);           // send read address to RTCC
    // I'm reading only 9 bytes (upto and including trim, there is 31 register in total if required)
    for ( t7=0; t7<8; t7++) RTCCDATA[t7] = RXbyte();
    RTCCDATA[8] = RXbyteACK(); // last byte, NO 9 use ack
    Restart();
    TXbyte(0xde);           // send write address to RTCC
    TXbyte(0x20);           // set ptr to 20, start of sram
    Restart();
    TXbyte(0xdf);           // send read address to RTCC
    // I'm reading all 64 bytes of sram
    for ( t7=0; t7<63; t7++) RTCCSRAM[t7] = RXbyte();
    RTCCSRAM[63] = RXbyteACK();
    Stop();                 // Generate stop bit
}

void WriteI2Crtcc()
{
    Start();                // start I2C exchange
    TXbyte(0xde);           // send write address to RTCC
    TXbyte(0x00);           // set ptr to 0
    for ( t7=0; t7<9; t7++)
        TXbyte(RTCCDATA[t7]); // write out registers 0 - 8
    Stop();                 // Generate stop bit
}

// A wake up routine for the RTCC to ensure all the correct register are on.
//
//
void RTCCSwitchon()
{
    Start();
    // setup oscillator on
    TXbyte(0xde);           // send write address to RTCC
    TXbyte(0x00);           // set ptr to register 0
    Restart();
    TXbyte(0xdf);           // send Read address to RTCC
    RTCCDATA[0] = RXbyteACK(); // read seconds + oscillator flag
    Restart();
    TXbyte(0xde);           // send write address to RTCC
    TXbyte(0x00);           // set ptr to register 0
    TXbyte(RTCCDATA[0]|0x80); // send back seconds with Osc flag set
    Restart();
    // now ensure the battery backup is enabled
    TXbyte(0xde);           // send write address to RTCC
    TXbyte(0x03);           // set ptr to register 3
    Restart();
    TXbyte(0xdf);           // send Read address to RTCC
    RTCCDATA[3] = RXbyteACK(); // read seconds + oscillator flag
    Restart();
    TXbyte(0xde);           // send write address to RTCC
    TXbyte(0x03);           // set ptr to register 3
    TXbyte(RTCCDATA[3]|0x08); // send back seconds with Osc flag set
    Restart();
}

```

```
// now setup general flags
    TXbyte(0xde);           // send write address to RTCC
    TXbyte(0x07);          // set ptr to 7, flags register
    TXbyte(0x40);          // sqw output at 1hz.
    Stop();                 // Generate stop bit
}

//      read the tnc75 temperature sensor
//
void ReadTemperature()
{
    Start();                // assert Start condition
    TXbyte(0x90);           // send 0x90 write address
    TXbyte(0x00);           // set read ptr to 0
    Restart();              // Generate another start bit
    TXbyte(0x91);           // 0x91 read address

    temperature=0;
    temperature = (WORD)RXbyte()<<8; // read high byte
    temperature |= (WORD)RXbyteACK(); // read low byte
    Stop();                 // Generate stop bit
    temperature >>= 7;      // shift down 7 bits for temp is now 6:1
}

// EEPROM read. The EEPROM write is more complicated as you will need to let the
// device finish its erase/write cycle. This is done by checking for an acknowledge
// from the EEPROM, see section 7.0 from the Microchip data sheet.
//
BYTE ReadI2cEByte(WORD a)
{
    Start();
    TXbyte(0xa0);           // 24lc512 write address
    TXbyte((BYTE)(w1>>8)); // set address high
    TXbyte((BYTE)(w1&0xff)); // set address low
    Restart();
    TXbyte(0xa1);           // 24lc512 read address
    t1 = RXbyteACK();
    Stop();
    return t1;
}
```