

QUAD DIFFERENTIAL COMPARATOR

The KA239 series consists of four independent voltage comparators designed to operate from single power supply over a wide voltage range.

FEATURES

- Single or dual supply operation
- Wide range of supply voltage KA239/A, KA339/A: 2 ~ 36V
 KA2901 (or $\pm 1 \sim \pm 18V$)
 KA3302: 2 ~ 28V
 (or $\pm 1 \sim \pm 14V$)
- Low supply current drain 800 μA Typ
- Open collector outputs for wired and connectors
- Low input bias current 25nA Typ
- Low Input offset current $\pm 2.3nA$ Typ.
- Low input offset voltage $\pm 1.4mV$ Typ.
- Common mode input voltage range includes ground.
- Low output saturation voltage
- Output compatible with TTL, DTL and MOS logic system

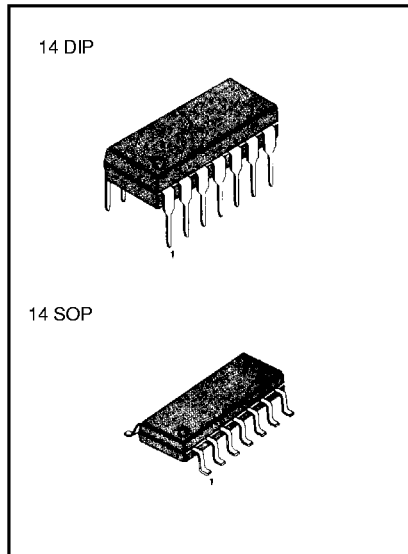

BLOCK DIAGRAM

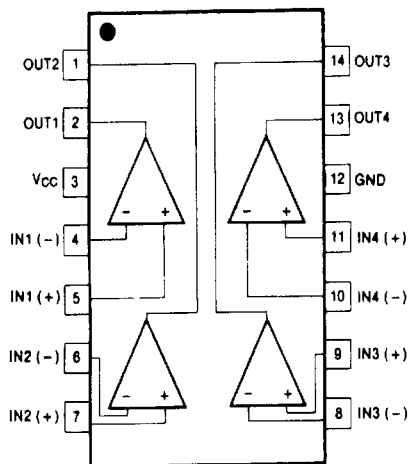

ORDERING INFORMATION

Device	Package	Operating Temperature
KA339 KA339A	14 DIP	0 ~ +70 °C
KA339D KA339AD	14 SOP	
KA239 KA239A	14 DIP	-25 ~ + 85 °C
KA239D KA239AD	14 SOP	
KA2901 KA2901D KA3302 KA3302D	14 DIP 14 SOP 14 DIP 14 SOP	-40 ~ + 85 °C

SCHEMATIC DIAGRAM

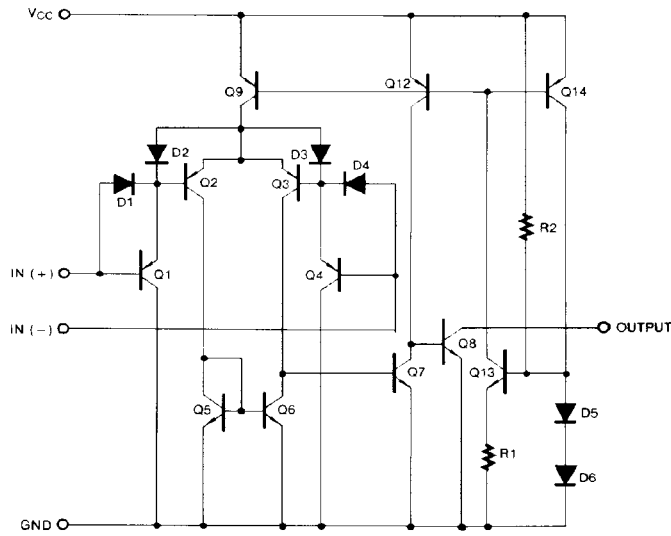

ABSOLUTE MAXIMUM RATINGS

Characteristic	Symbol	Value	Unit
Supply Voltage	V _{CC}	± 18 or 36	V
Supply Voltage Only KA3302	V _{CC}	± 14 or 28	V
Differential Input Voltage	V _{I(DIFF)}	36	V
Differential Input Voltage Only KA3302	V _{I(DIFF)}	28	V
Input Voltage	V _I	- 0.3 to +36	V
Input Voltage Only KA3302	V _I	- 0.3 to +28	V
Output Short Circuit to GND		Continuous	
Power Dissipation	P _D	570	mW
Operating Temperature KA339/KA339A		0 ~ + 70	°C
KA239/KA239A	T _{OPR}	- 25 ~ + 85	°C
KA2901/KA3302		- 40 ~ + 85	°C
Storage Temperature	T _{STG}	- 65 ~ + 150	°C



ELECTRICAL CHARACTERISTICS

(V_{CC} = 5V, T_A = 25 °C, unless otherwise specified)

Characteristic	Symbol	Test Conditions	KA239A/KA339A			KA239/KA339			Unit
			Min	Typ	Max	Min	Typ	Max	
Input Offset Voltage	V _{IO}	V _{CM} = 0V to V _{CC} = 1.5V		±1	±2		±1.4	±5	mV
		V _{O(P)} = 1.4V, R _S = 0Ω	NOTE 1		±4.0			±9.0	
Input Offset Current	I _{IO}			±2.3	±50		±2.3	±50	nA
		NOTE 1			±150			±150	
Input Bias Current	I _{BIAS}			57	250		57	250	nA
		NOTE 1			400			400	
Input Common Mode Voltage Range	V _{I(R)}		0		V _{CC} -1.5	0		V _{CC} -1.5	V
		NOTE 1	0		V _{CC} -2	0		V _{CC} -2	
Supply Current	I _{CC}	R _L = ∞		1.1	2.0		1.1	2.0	mA
Voltage Gain	G _V	V _{CC} = 15V, R _L = 15KΩ (for large swing)	50	200		50	200		V/mV
Large Signal Response Time	t _{RES}	V _I = TTL Logic Swing		350			350		ns
		V _{REF} = 1.4V, V _{RL} = 5V, R _L = 5.1KΩ							
Response Time	t _{RES}	V _{RL} = 5V, R _L = 5.1KΩ		1.4			1.4		μs
Output Sink Current	I _{SINK}	V _{I(-)} = 1V, V _{I(+)} = 0V, V _{O(P)} ≤ 1.5V	6	18		6	18		mA
Output Saturation Voltage	V _{SAT}	V _{I(-)} = 1V, V _{I(+)} = 0V		140	400		140	400	mV
		I _{SINK} = 4mA	NOTE 1		700			700	
Output Leakage Current	I _{O(LKG)}	V _{I(-)} = 0V	V _{O(P)} = 5V	0.1			0.1		nA
		V _{I(+)} = 1V	V _{O(P)} = 30V		1.0			1.0	μA
Differential Voltage	V _{I(DIFF)}		NOTE 1		36			36	V

Note 1.

KA339/A: 0 ≤ T_A ≤ +70 °CKA239/A: -25 ≤ T_A ≤ +85 °CKA2901/3302: -40 ≤ T_A ≤ +85 °C

ELECTRICAL CHARACTERISTICS

(V_{CC} = 5V, T_A = 25 °C, unless otherwise specified)

Characteristic	Symbol	Test Conditions	KA2901			KA3302			Unit
			Min	Typ	Max	Min	Typ	Max	
Input Offset Voltage	V _{IO}	V _{CM} = 0V to V _{CC} = 1.5V V _{O(P)} = 1.4V, R _S = 0Ω		2	7		2	20	mV
			NOTE 1	9	15		40		
Input Offset Current	I _{IO}			2.3	50		3	100	nA
			NOTE 1	50	200		300		
Input Bias Current	I _{BIAS}			57	250		57	250	nA
			NOTE 1	200	500		1000		
Input Common Mode Voltage Range	V _{I(R)}			0	V _{CC} -1.5		0	V _{CC} -1.5	V
			NOTE 1	0	V _{CC} -2		0	V _{CC} -2	
Supply Current	I _{CC}	R _L = ∞ R _L = ∞, V _{CC} = 30V		1.1	2.0		1.1	2.0	mA
				1.6	2.5				
Voltage Gain	G _V	V _{CC} = 15V, R _L = 15KΩ (for large swing)	25	100		2	30	V/mV	
Large Signal Response Time	t _{RES}	V _I = TTL Logic Swing V _{REF} = 1.4V, V _{RL} = 5V, R _L = 5.1KΩ		350			350	ns	
Response Time	t _{RES}	V _{RL} = 5V, R _L = 5.1KΩ		1.4			1.4	μs	
Output Sink Current	I _{SINK}	V _{I(-)} = 1V, V _{I(+)} = 0V, V _{O(P)} ≤ 1.5V	6	18		6	18	mA	
Output Saturation Voltage	V _{SAT}	V _{I(-)} = 1V, V _{I(+)} = 0V I _{SINK} = 4mA		140	400		140	400	mV
			NOTE 1		700		700		
Output Leakage Current	I _{O(LKG)}	V _{I(-)} = 0V V _{I(+)} = 1V		0.1			0.1	nA	
			V _{O(P)} = 5V V _{O(P)} = 30V			1.0		1.0	μA
Differential Voltage	V _{I(DIFF)}				36		36	V	

Note 1.

KA339/A: 0 ≤ T_A ≤ +70 °CKA239/A: -25 ≤ T_A ≤ +85 °CKA2901/3302: -40 ≤ T_A ≤ +85 °C

TYPICAL PERFORMANCE CHARACTERISTICS

Fig. 1 SUPPLY CURRENT

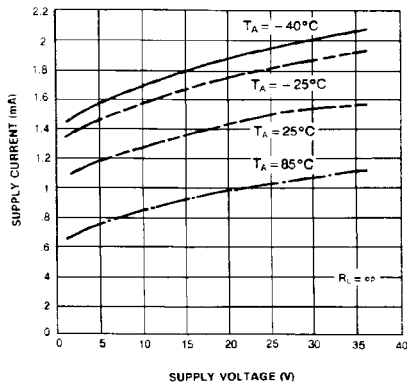

Fig. 2 INPUT CURRENT

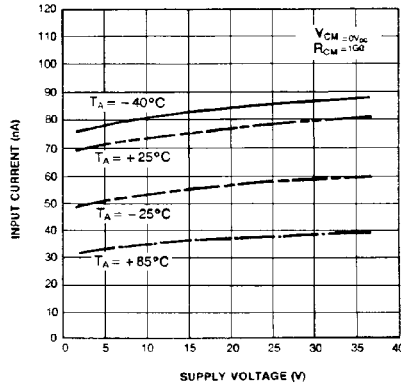

Fig. 3 OUTPUT SATURATION VOLTAGE

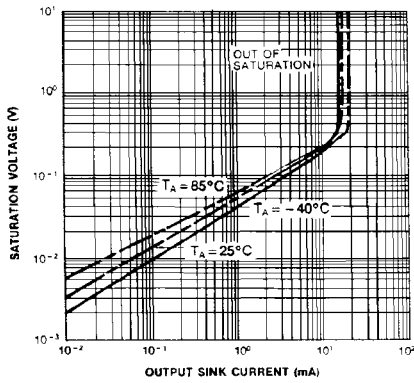

Fig. 4 RESPONSE TIME FOR VARIOUS INPUT OVERDRIVE-NEGATIVE TRANSITION

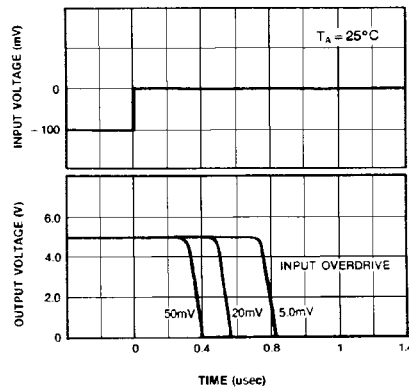
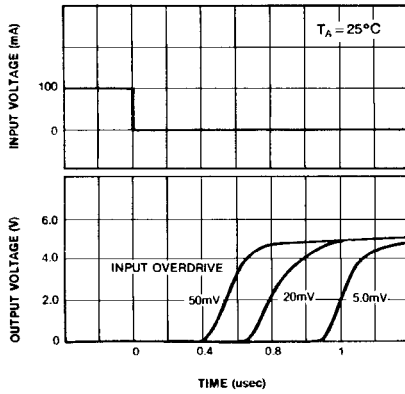

Fig. 5 RESPONSE TIME FOR VARIOUS INPUT OVERDRIVE-POSITIVE TRANSITION



TRADEMARKS

The following are registered and unregistered trademarks Fairchild Semiconductor owns or is authorized to use and is not intended to be an exhaustive list of all such trademarks.

ACE ^x ™	ISOPLANAR™	UHC™
CoolFET™	MICROWIRE™	VCX™
CROSSVOLT™	POP™	
E ² CMOS™	PowerTrench™	
FACT™	QS™	
FACT Quiet Series™	Quiet Series™	
FAST®	SuperSOT™-3	
FASTr™	SuperSOT™-6	
GTO™	SuperSOT™-8	
HiSeC™	TinyLogic™	

DISCLAIMER

FAIRCHILD SEMICONDUCTOR RESERVES THE RIGHT TO MAKE CHANGES WITHOUT FURTHER NOTICE TO ANY PRODUCTS HEREIN TO IMPROVE RELIABILITY, FUNCTION OR DESIGN. FAIRCHILD DOES NOT ASSUME ANY LIABILITY ARISING OUT OF THE APPLICATION OR USE OF ANY PRODUCT OR CIRCUIT DESCRIBED HEREIN; NEITHER DOES IT CONVEY ANY LICENSE UNDER ITS PATENT RIGHTS, NOR THE RIGHTS OF OTHERS.

LIFE SUPPORT POLICY

FAIRCHILD'S PRODUCTS ARE NOT AUTHORIZED FOR USE AS CRITICAL COMPONENTS IN LIFE SUPPORT DEVICES OR SYSTEMS WITHOUT THE EXPRESS WRITTEN APPROVAL OF FAIRCHILD SEMICONDUCTOR CORPORATION. As used herein:

1. Life support devices or systems are devices or systems which, (a) are intended for surgical implant into the body, or (b) support or sustain life, or (c) whose failure to perform when properly used in accordance with instructions for use provided in the labeling, can be reasonably expected to result in significant injury to the user.
2. A critical component is any component of a life support device or system whose failure to perform can be reasonably expected to cause the failure of the life support device or system, or to affect its safety or effectiveness.

PRODUCT STATUS DEFINITIONS

Definition of Terms

Datasheet Identification	Product Status	Definition
Advance Information	Formative or In Design	This datasheet contains the design specifications for product development. Specifications may change in any manner without notice.
Preliminary	First Production	This datasheet contains preliminary data, and supplementary data will be published at a later date. Fairchild Semiconductor reserves the right to make changes at any time without notice in order to improve design.
No Identification Needed	Full Production	This datasheet contains final specifications. Fairchild Semiconductor reserves the right to make changes at any time without notice in order to improve design.
Obsolete	Not In Production	This datasheet contains specifications on a product that has been discontinued by Fairchild semiconductor. The datasheet is printed for reference information only.