

**PRELIMINARY
DATA SHEET**

**GD74F04
HEX INVERTER**

Description

The GD74F04 contains 6 logic inverters which accept standard TTL input signal and standard TTL output level. They have a greater noise margin than conventional inverters.

Pin Configuration

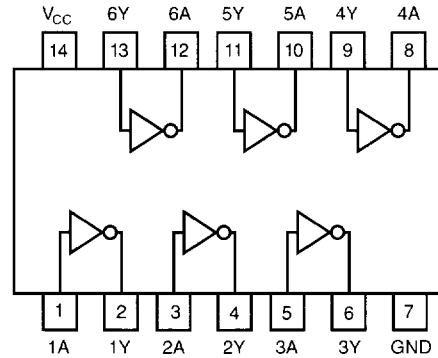

Package Type: 14 DIP, 14 SOP Available

Function Table (each inverter)

Inputs	Outputs
L	H
H	L

Waveform Of Functions

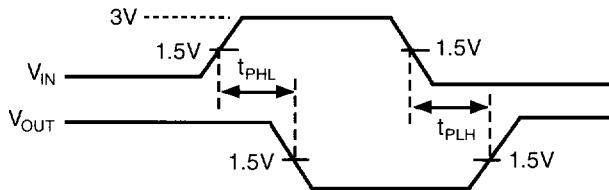

Input Condition

Frequency : 1.0 MHz
 Duty Cycle : 50%
 Rising Time : 2.5 ns
 Falling Time : 2.5 ns
 Amplitude : 0 to 3V

Absolute Maximum Ratings

- Storage Temperature -65°C to 150°C
- Ambient Temperature Under Bias -55°C to 125°C
- Junction Temperature Under Bias..... -55°C to 175°C
- V_{CC} Voltage -0.5 V to 7.0 V
- Input Voltage -5.0 V to 7.0 V
- Input Current -30 mA to 5.0 mA
- Output Voltage..... -0.5 V to V_{CC}

Note: Absolute Maximum ratings are values beyond which the device may be damaged or have its useful life impaired. Functional operation under these conditions is not implied.

Recommended Operating Conditions

SYMBOL	PARAMETER	MIN	MAX	UNIT
T _{AA}	Free Air Ambient Temperature	0°	70°	°C
V _{CC}	Supply Voltage	4.5	5.5	V

AC Characteristics

SYMBOL	PARAMETER	TEST CONDITIONS						UNIT
		TA = 25°C			TA = 0°C to 70°C			
		V _{CC} = 5.0 V			V _{CC} = 5 V +10%			
		C _L = 50 pF			C _L = 50 pF			
		Min	Typ	Max	Min	Typ	Max	
t _{PLH}	Propogation	2.4	3.7	5.0	2.4	—	6.0	ns
t _{PHL}	Delay	1.5	3.2	4.3	1.5	—	5.3	ns

DC Electrical Characteristics over recommended operating free-air temperature range

SYMBOL	PARAMETER	TEST CONDITION	MIN	TYP	MAX	UNIT
V _{IH}	Input High Voltage	—————	2.0			V
V _{IL}	Input Low Voltage	—————			0.8	V
V _{CD}	Input Clamp Diode Voltage	V _{CC} = Min, I _{IN} = -18 mA			-1.2	V
V _{OH}	Output High Voltage	V _{CC} = 4.5 V, I _{OH} = 1 mA	2.5			V
		V _{CC} = 4.75 V, I _{OH} = 1 mA	2.7			
V _{OL}	Output Low Voltage	V _{CC} = Min, I _{OL} = 20mA			0.5	V
I _I	Input High Breakdown	V _{CC} = Max, V _I = 7.0 V			7.0	μA
I _{IH}	Input High Current	V _{CC} = Max, V _I = 2.7 V			5.0	μA
I _{IL}	Input Low Current	V _{CC} = Max, V _I = 0.5 V			-0.6	mA
I _{ILK}	Input Leakage Circuit Current	V _{I1} = 4.75 V All other pins grounded			1.9	μA
I _{OLK}	Output Leakage Circuit Current	V _{IC} = 150 mA All other pins grounded			3.75	μA
I _{OS}	Output Short Current	V _{CC} = Max, V _O = 0 V	-60		-150	mA
I _{CCH}	Supply Current	V _{CC} = Max, V _I = Gnd.		2.8	4.2	mA
I _{CCL}	Supply Current	V _{CC} = Max, V _I = Open		10.2	15.3	mA