

# Customer Information Sheet

DRAWING No.: M80-620XXX

SHEET 2 OF 2

IF IN DOUBT - ASK

©

NOT TO SCALE

THIRD ANGLE PROJECTION

ALL DIMENSIONS IN mm

ORDER CODE:

**M80-620XXX**

TOTAL No. OF WAYS

04, 06, 08, 10, 12, 14, 16,  
18, 20, 26, 34, 44

FINISH:

22 = GOLD + TIN/LEAD  
42 = GOLD + 100% TIN  
45 = GOLD

SPECIFICATIONS:

MATERIAL:

MOULDING = POLYAMIDE 46 UL94V-0, BLACK

CONTACTS = PHOSPHOR BRONZE

LATCHES = BERYLLIUM COPPER

FINISH:

CONTACTS:

22 = 0.75µ GOLD ON CONTACT AREA.

3.0µ 90/10 TIN/LEAD ON TAILS

42 = 0.75µ GOLD ON CONTACT AREA

3.0µ 100% TIN ON TAILS

45 = 0.75µ GOLD

ELECTRICAL:

CURRENT RATING (25°C) = 3.0A MAX.

CURRENT RATING (85°C) = 2.2A MAX.

WORKING VOLTAGE = 120V AC/DC

VOLTAGE PROOF = 360V AC/DC

CONTACT RESISTANCE (INITIAL) = 20 mΩ MAX.

CONTACT RESISTANCE

(AFTER CONDITIONING) = 25 mΩ MAX.

INSULATION RESISTANCE

(INITIAL) = 1000 MΩ MIN.

INSULATION RESISTANCE

(AFTER CONDITIONING) = 100 MΩ MIN.

MECHANICAL:

DURABILITY = 500 OPERATIONS

ENVIRONMENTAL:

TEMPERATURE RANGE = -55°C TO +125°C

PACKING:

TUBE

FOR COMPLETE SPECIFICATION, SEE COMPONENT SPECIFICATION C005XX (LATEST ISSUE)

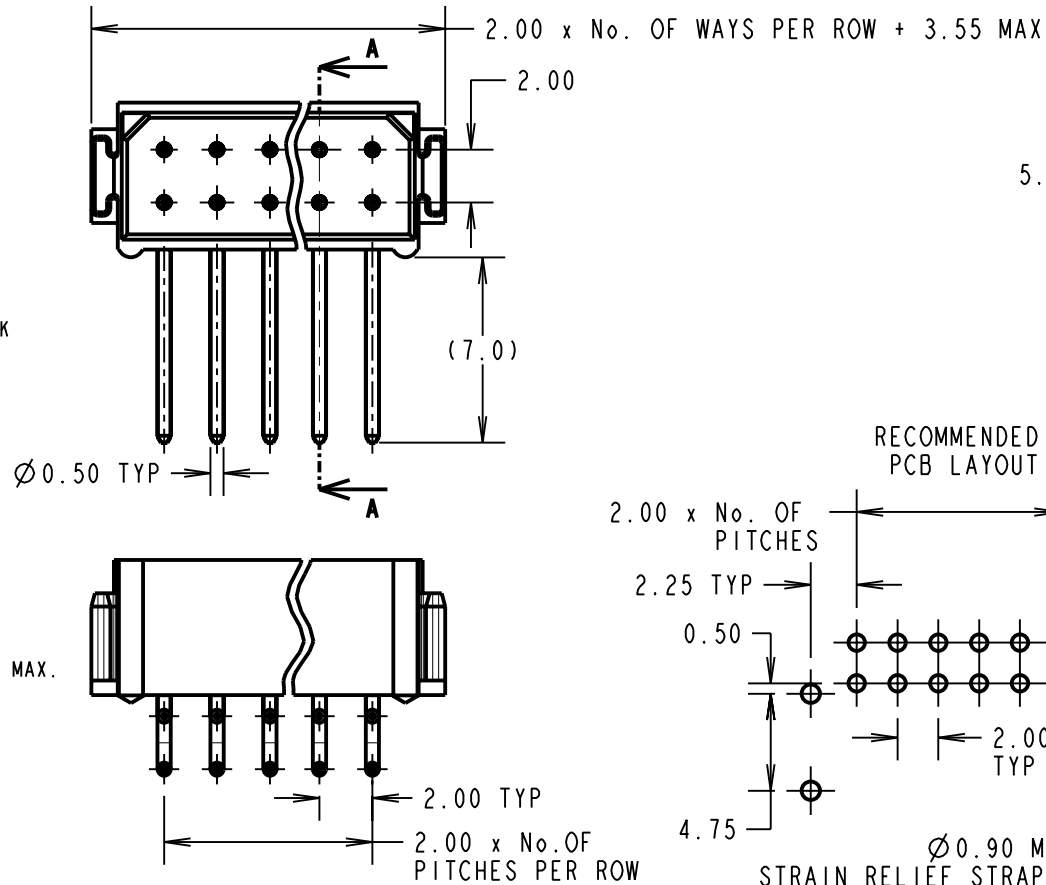

SECTION A-A

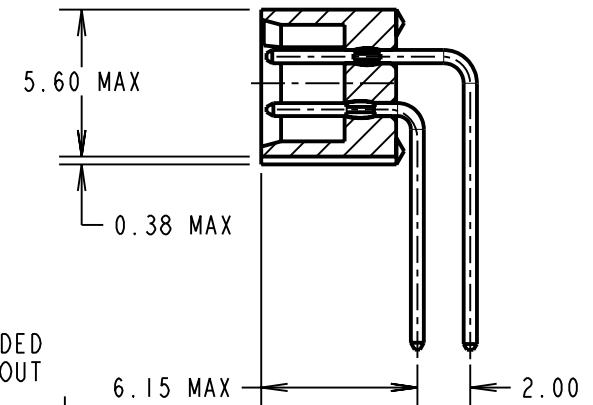

NOTES:

- 2-OFF STRAIN RELIEF STRAPS M80-0780006 ARE INCLUDED WITH EACH CONNECTOR.

CP	4	10.09.09	10478
NAME	ISS.	DATE	C/NOTE
APPROVED: C.PENROSE			
CHECKED: R.ADDE			
DRAWN: I. SANDY			
CUSTOMER REF.:			
ASSEMBLY DRG:			

**HARWIN**

HARWIN USA TEL: 603 893 5376 FAX: 603 893 5396 mis@harwin.com	HARWIN Europe (UK) TEL: 023 9231 4545 FAX: 023 9231 4590 mis@harwin.co.uk	HARWIN Asia TEL: +65 6 779 4909 FAX: +65 6 779 3868 mis@harwin.com.sg
------------------------------------------------------------------------	------------------------------------------------------------------------------------	--------------------------------------------------------------------------------

THIS DRAWING AND ANY INFORMATION OR DESCRIPTIVE MATTER SET OUT HEREON ARE CONFIDENTIAL AND COPYRIGHT PROPERTY OF THE HARWIN GROUP AND MUST NOT BE DISCLOSED, LOANED, COPIED OR USED FOR MANUFACTURING, TENDERING OR FOR ANY OTHER PURPOSE WITHOUT THEIR WRITTEN PERMISSION.

TOLERANCES  
X. = ±1mm  
X.X = ±0.25mm  
X.XX = ±0.10mm  
X.XXX = ±0.01mm  
ANGLES = ±5°  
UNLESS STATED

MATERIAL: SEE ABOVE  
FINISH: SEE ABOVE  
S/AREA: mm<sup>2</sup>

TITLE: DATAMATE DIL HORIZONTAL PC TAIL PLUG ASSEMBLY - UNLATCHED  
DRAWING NUMBER: M80-620XXX  
SHT 2 OF 2