

**INCH-POUND**

MS21254U  
20 November 2002  
SUPERSEDING  
MS21254T  
5 November 2001

DETAIL SPECIFICATION SHEET

EYE END, TURNBUCKLE, CLIP LOCKING

This specification is approved for use by all Departments and Agencies of the Department of Defense.

The requirements for acquiring the product described herein shall consist of this specification sheet and the issue of MIL-DTL-8878 and QPL-8878 listed in that issue of the Department of Defense Index of Specifications and Standards (DoDISS) specified in the solicitation.

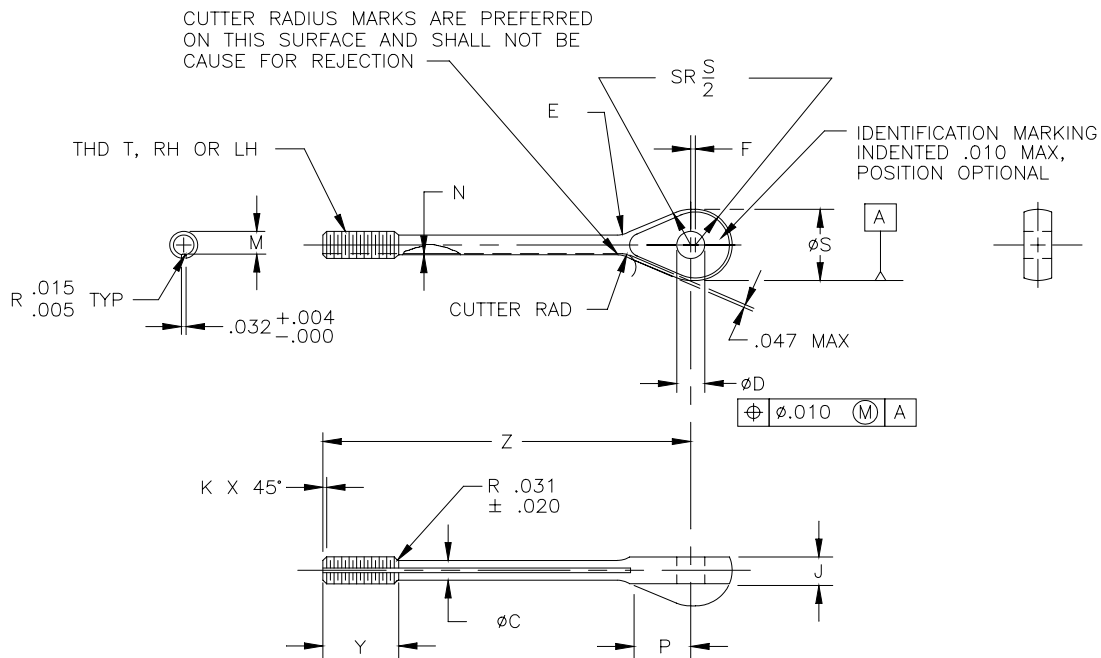

FIGURE 1. Eye end, turnbuckle, clip locking.

MS21254U

TABLE I. Dash numbers and dimensions.

Dash number		Wire rope diameter		Minimum breaking strength lbs.	Thread T UNF-3A	ØC +0.006 -0.000	ØD +0.002 -0.000	E ±0.031 radius	F +0.010 -0.000	J ±0.005
Direction of thread		Nominal reference	Minimum							
RH	LH									
-2RS	-2LS	1/16	0.062	800	0.1380 (#6)-40	0.094	0.190	0.125	0.031	0.125
-2RL	-2LL									
-3RS	-3LS	3/32	0.093	1,600	0.190 (#10)-32	0.133	0.156	0.219	0.047	0.188
-3RL	-3LL									
-5RS	-5LS	5/32	0.156	3,200	0.250 (1/4)-28	0.189	0.250	0.219	0.047	0.219
-5RL	-5LL	1/								
-6RS	-6LS	3/16	0.187	4,600	0.3125 (5/16)-24	0.243	0.313	0.250	0.063	0.281
-6RL	-6LL									
-8RL	-8LL	1/4	0.250	8,000	0.3750 (3/8)-24	0.306	0.375	0.281	0.063	0.328
-9RL	-9LL	9/32	0.281	12,500	0.4375 (7/16)-20	0.362	0.438	0.359	0.078	0.375
-10RL	-10LL	5/16	0.312	17,500	0.5000 (1/2)-20	0.425	0.500	0.406		0.469

1/ See note 6.

TABLE I. Dash numbers and dimensions - Continued.

Dash number		Wire rope diameter		K +0.000 -0.015	M		N	P ±0.031	ØS +0.025 -0.010	Y ±0.047 2/	Z +0.031 -0.015
Direction of thread		Nominal reference	Minimum		Maximum	Minimum					
RH	LH										
-2RS	-2LS	1/16	0.062	0.031	0.1139	0.1094	0.0096	0.325	0.375	0.375	1.500
-2RL	-2LL										2.375
-3RS	-3LS	3/32	0.093	0.031	0.1638	0.1568	0.0077	0.416	0.500	0.500	1.625
-3RL	-3LL										2.500
-5RS	-5LS	5/32	0.156	0.031	0.2224	0.2152	0.0103	0.512	0.625	0.625	1.750
-5RL	-5LL										2.625
-6RS	-6LS	3/16	0.187	0.047	0.2830	0.2754	0.0064	0.527	0.688	0.750	1.875
-6RL	-6LL										2.750
-8RL	-8LL	1/4	0.250	0.063	0.3454	0.3378	0.0057	0.678	0.875	0.875	2.875
-9RL	-9LL	9/32	0.281	0.063	0.4052	0.3972	0.0056	0.831	1.063	1.000	3.375
-10RL	-10LL	5/16	0.312	0.063	0.4678	0.4597	0.0058	0.900	1.188		3.625

2/ Includes last full thread engagement.

REQUIREMENTS:

1. Material: Material shall be in accordance with MIL-DTL-8878.
2. Protective treatment: Protective treatment shall be in accordance with MIL-DTL-8878.
3. Heat treatment: Heat treatment shall be in accordance with MIL-DTL-8878.
4. Finish: Finish shall be in accordance with MIL-DTL-8878.
5. Threads: Threads shall be in accordance with FED-STD-H28/20.
6. Tolerances: Unless otherwise specified, tolerances: decimals ± 0.010, angles ± 0.5°.

7. Outside diameter (O.D.): O.D. of the "F" dimension may be a flat area.

NOTES:

1. Part or identifying number (PIN): The part or identifying number (PIN) consists of the letters MS, the specification sheet number, and a dash number taken from table I. A "C" in lieu of dash indicates 17-4PH; a dash indicates carbon or alloy steel. The first letter following the dash number or letter C indicates direction of thread (left or right hand) and the second letter indicates length (short or long).

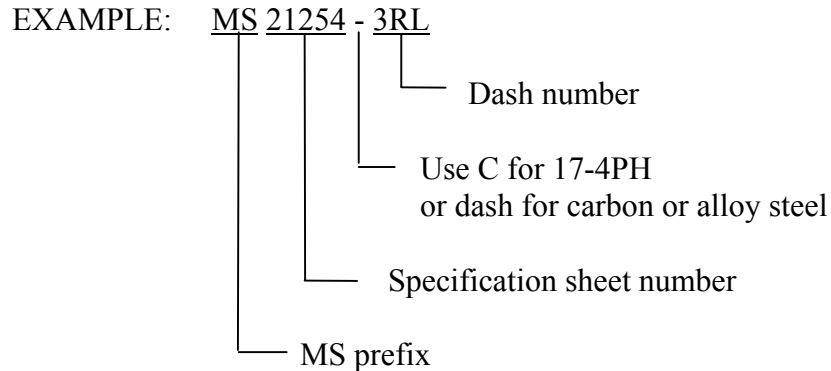

MS21254C3LS Indicates - Eye, turnbuckle, 17-4PH, 0.1900 (#10)-32 left hand thread, short.  
 MS21254-3RL Indicates - Eye, turnbuckle, steel, 0.1900 (#10)-32 right hand thread, long.

2. Remove burrs and sharp edges. (See MIL-DTL-8878.)
3. Dimensions are in inches.
4. Interpret drawing in accordance with ASME Y14.5M.
5. MS21254 items can replace AN165 items of like thread size and material.
6. For 0.125 (1/8) inch diameter wire rope use -5 parts, minimum breaking strength 2,200 pounds (lbs.) (reference).
7. Steel, carbon and alloy eye end turnbuckles are inactive for new design. 17-4PH stainless steel eye end turnbuckles shall be used for new design and can be used to replace comparable steel parts.
8. In the event of a conflict between the text of this document and the references cited herein, the text of this document takes precedence.
9. Unless otherwise specified, issues of referenced documents are those in effect at the time of solicitation.
10. For clip locking of turnbuckles, see MS33736 and MIL-DTL-8878.

11. The parts covered by dash numbers shown on AN165 are canceled after 25 November 1963. Use the dash numbers given in table I. The canceled parts cannot replace the new parts and should be used until existing stock is depleted. Use only the MS21254 parts for new design and substitution. Substitution shall be in accordance with table II.

TABLE II. Substitution table.

PART NUMBER	
Canceled part AN165	New part MS21254
Dash number	Dash number
8	2
16	3
22	5
32	5
46	6
61	8
80	8
125	9
175	10

CHANGES FROM PREVIOUS ISSUE: The margins of this specification sheet are marked with asterisks to indicate where changes from the previous issue were made. This was done as a convenience only and the Government assumes no liability whatsoever for any inaccuracies in these notations. Bidders and contractors are cautioned to evaluate the requirements of this document based on the entire content irrespective of the marginal notations and relationship to the previous issue.

Custodians:

Army - AV  
Navy - AS  
Air Force - 99

Preparing Activity:

DLA - GS5  
(Project 1560-0022)

Review Activities:

Navy - MC  
Air Force - 71