

RoHS Compliant Product
A suffix of "-C" specifies halogen and lead-free

DESCRIPTION

These miniature surface mount MOSFETs utilize a high cell density trench process to provide low R_{DS(on)} and to ensure minimal power loss and heat dissipation. Typical applications are DC-DC converters and power management in portable and battery-powered products such as computers, printers, PCMCIA cards, cellular and cordless telephones.

FEATURES

- Low R_{DS(on)} provides higher efficiency and extends battery life.
- Low thermal impedance copper leadframe TSOP-6 saves board space.
- Fast switching speed.
- High performance trench technology.

TSOP-6

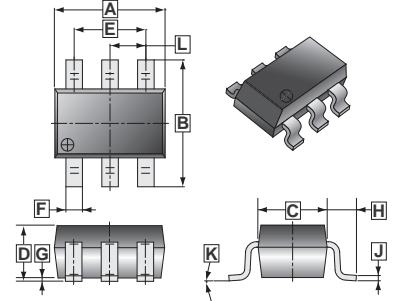

REF.	Millimeter		REF.	Millimeter	
	Min.	Max.		Min.	Max.
A	2.70	3.10	G	0	0.10
B	2.60	3.00	H	0.60	REF.
C	1.40	1.80	J	0.12	REF.
D	1.10	MAX.	K	0°	10°
E	1.90	REF.	L	0.95	REF.
F	0.30	0.50			

PRODUCT SUMMARY

PRODUCT SUMMARY		
V _{DS} (V)	R _{DS(on)} (mΩ)	I _D (A)
-20	42@V _{GS} = -4.5V	-5.7
	57@V _{GS} = -2.5V	-4.9
	80@V _{GS} = -1.8V	-4.1

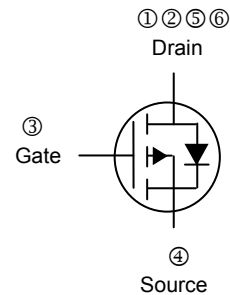
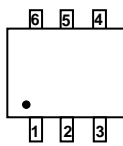

ABSOLUTE MAXIMUM RATINGS(T_A=25°C UNLESS OTHERWISE NOTED)

Parameter	Symbol	Ratings	Unit
		Maximum	
Drain-Source Voltage	V _{DS}	-20	V
Gate-Source Voltage	V _{GS}	±8	V
Continuous Drain Current ^a	I _D @TA=25°C	-5.7	A
	I _D @TA=70°C	-4.7	
Pulsed Drain Current ^b	I _{DM}	±20	A
Continuous Source Current (Diode Conduction) ^a	I _S	-1.7	A
Power Dissipation ^a	P _D @TA=25°C	2.0	W
	P _D @TA=70°C	1.3	
Operating Junction and Storage Temperature Range	T _j , T _{stg}	-55 ~ 150	°C

THERMAL RESISTANCE RATINGS

Parameter	Symbol	Maximum	Unit
Maximum Junction to Ambient ^a	R _{θJA}	50	°C / W
		90	

Notes

- a. Surface Mounted on 1" x 1" FR4 Board.
- b. Pulse width limited by maximum junction temperature.

ELECTRICAL CHARACTERISTICS ($T_A = 25^\circ\text{C}$ unless otherwise specified)

Parameter	Symbol	Min.	Typ.	Max.	Unit	Test Conditions
Gate-Threshold Voltage	$V_{GS(th)}$	-0.4	-	-	V	$V_{DS}=V_{GS}$, $I_D = -250\mu\text{A}$
Gate-Body Leakage	I_{GSS}	-	-	± 100	nA	$V_{DS}=0\text{V}$, $V_{GS}=\pm 8\text{V}$
Zero Gate Voltage Drain Current	I_{DSS}	-	-	-1	uA	$V_{DS} = -16\text{V}$, $V_{GS} = 0\text{V}$
		-	-	-5		$V_{DS} = -16\text{V}$, $V_{GS}=0\text{V}$, $T_J = 55^\circ\text{C}$
On-State Drain Current ^a	$I_{D(on)}$	-20	-	-	A	$V_{DS} = -4.5\text{V}$, $V_{GS} = -4.5\text{V}$
Drain-Source On-Resistance ^a	$R_{DS(ON)}$	-	-	42	m Ω	$V_{GS} = -4.5\text{V}$, $I_D = -5.7\text{A}$
		-	-	57		$V_{GS} = -2.5\text{V}$, $I_D = -4.9\text{A}$
		-	-	80		$V_{GS} = -1.8\text{V}$, $I_D = -4.1\text{A}$
Forward Transconductance ^a	g_{fs}	-	10	-	S	$V_{DS} = -10\text{V}$, $I_D = -4.9\text{A}$
Diode Forward Voltage ^a	V_{SD}	-	-0.7	-	V	$I_S = 1.7\text{A}$, $V_{GS} = 0\text{V}$
DYNAMIC ^b						
Total Gate Charge	Q_g	-	8	-	nC	$V_{DS} = -10\text{V}$, $V_{GS} = -4.5\text{V}$, $I_D = -5.7\text{A}$
Gate-Source Charge	Q_{gs}	-	1.8	-		
Gate-Drain Charge	Q_{gd}	-	1.9	-		
Turn-on Delay Time	$T_{d(on)}$	-	22	-	nS	$V_{DD} = -10\text{V}$, $V_{GEN} = -4.5\text{V}$, $R_L = 6\Omega$, $I_D = -1\text{A}$
Rise Time	T_r	-	35	-		
Turn-off Delay Time	$T_{d(off)}$	-	45	-		
Fall Time	T_f	-	25	-		

Notes

- a. Pulse test : $PW \leq 300\ \mu\text{s}$ duty cycle $\leq 2\%$.
- b. Guaranteed by design, not subject to production testing.

CHARACTERISTIC CURVES

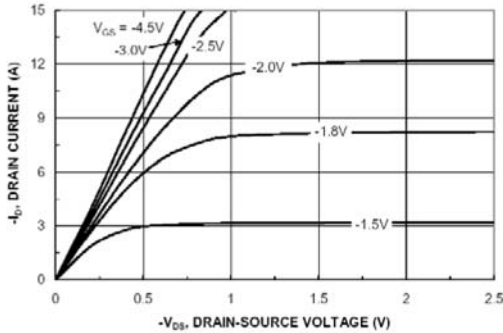

Figure 1. On-Region Characteristics

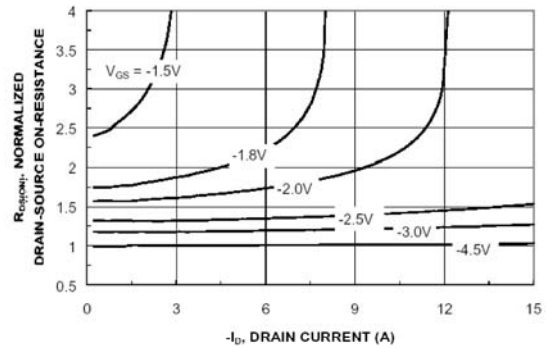

Figure 2. On-Resistance Variation with Drain Current and Gate Voltage

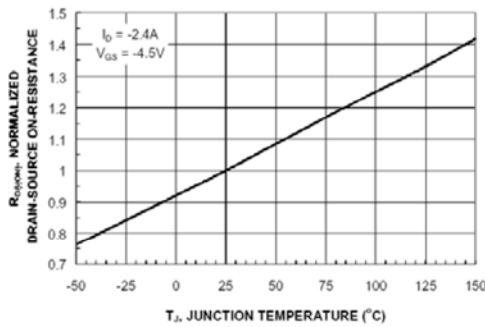

Figure 3. On-Resistance Variation with Temperature

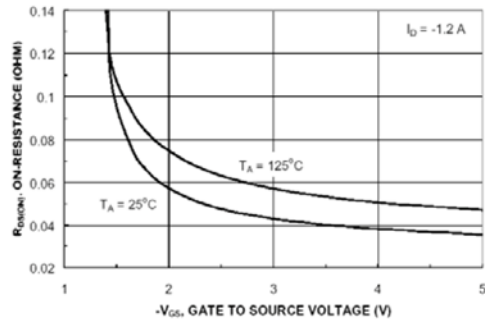

Figure 4. On-Resistance Variation with Gate to Source Voltage

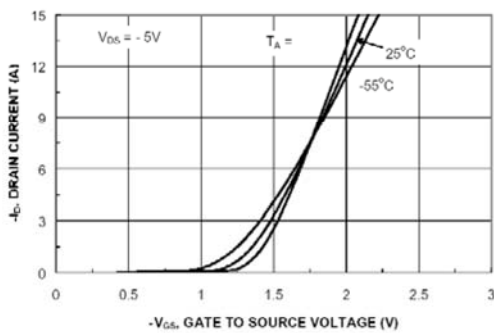

Figure 5. Transfer Characteristics

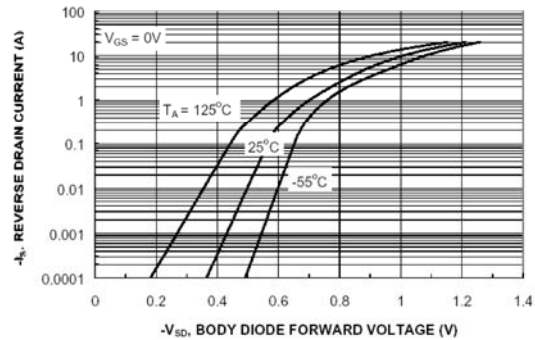

Figure 6. Body Diode Forward Voltage Variation with Source Current and Temperature

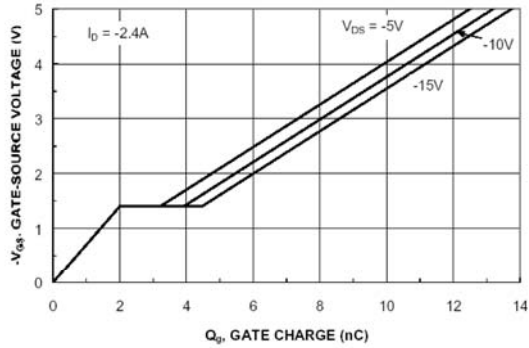

Figure 7. Gate Charge Characteristic

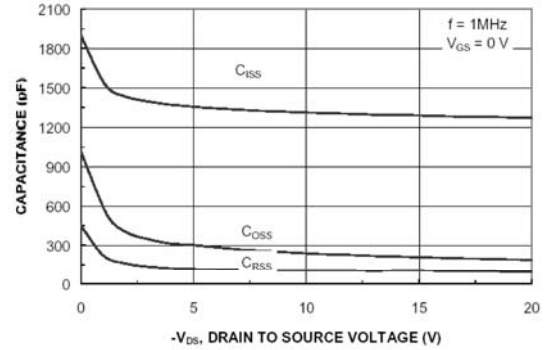

Figure 8. Capacitance Characteristic

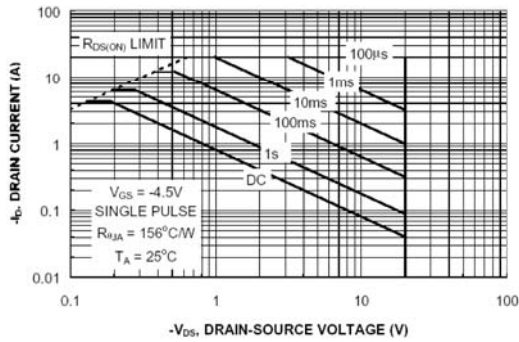

Figure 9. Maximum Safe Operating Area

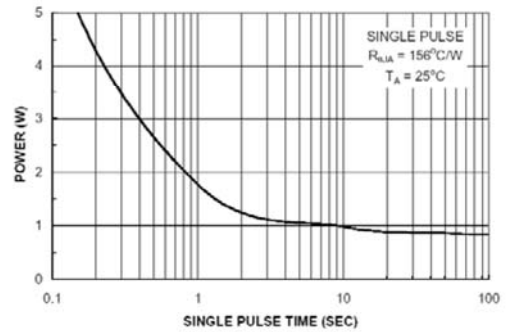

Figure 10. Single Pulse Maximum Power Dissipation

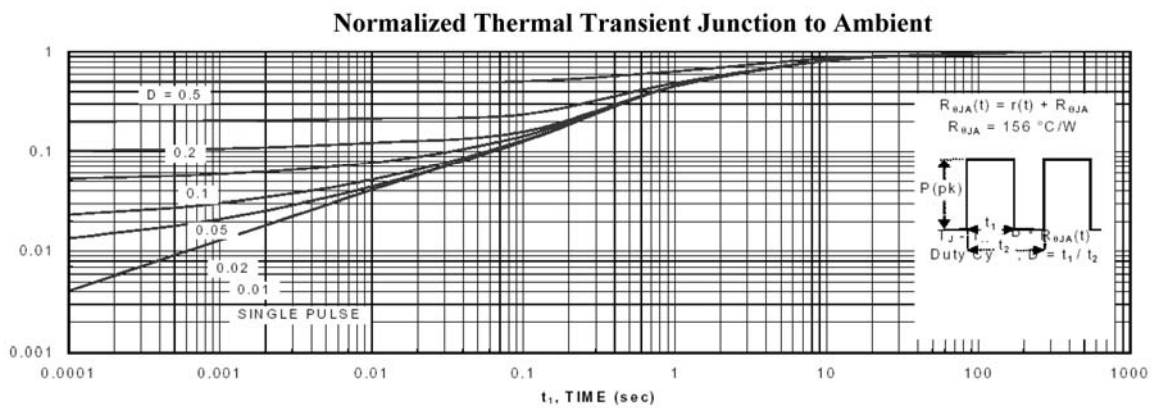

Figure 11. Transient Thermal Response Curve.