

TPD4101K

The TPD4101K is a DC brush less motor driver using high voltage PWM control. It is fabricated by high voltage SOI process.

The device contains a PWM circuit, 3-phase decode logic, level shift high-side driver, low-side driver, IGBT outputs, FRDs, over current and under voltage protection circuits, and a thermal shutdown circuit.

It is easy to control a DC brush less motor by applying a signal from a motor controller and a hole IC to the TPD4101K.

Features

- Bootstrap circuit gives simple high side supply.
- Bootstrap diode is built in.
- PWM and 3-phase decoder circuits are built in.
- Outputs rotation pulse signals.
- 3-phase bridge output using IGBTs
- FRDs are built in
- Incorporating protection against over current, under voltage protection, and thermal shutdown
- Package: 23-pin HZIP

This product has a MOS structure and is sensitive to electrostatic discharge. When handling this product, ensure that the environment is protected against electrostatic discharge.

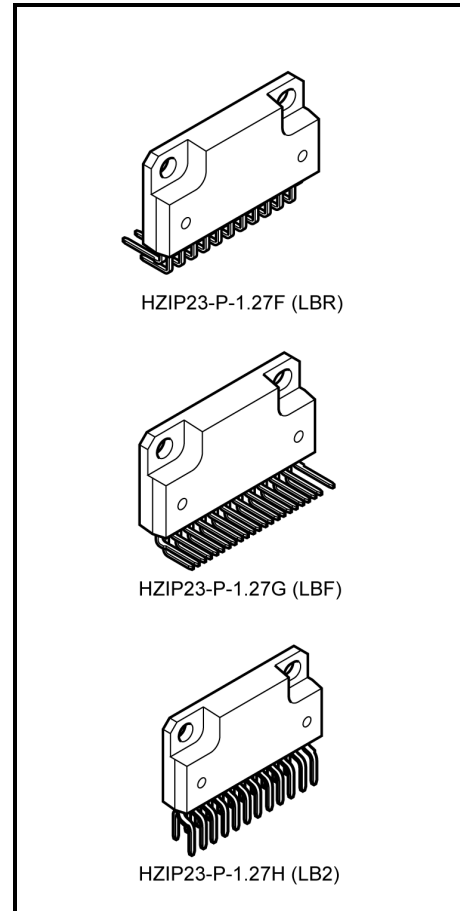

Weight

HZIP23-P-1.27F : 6.1 g (typ.)

HZIP23-P-1.27G : 6.1 g (typ.)

HZIP23-P-1.27H : 6.1 g (typ.)

Pin Assignment

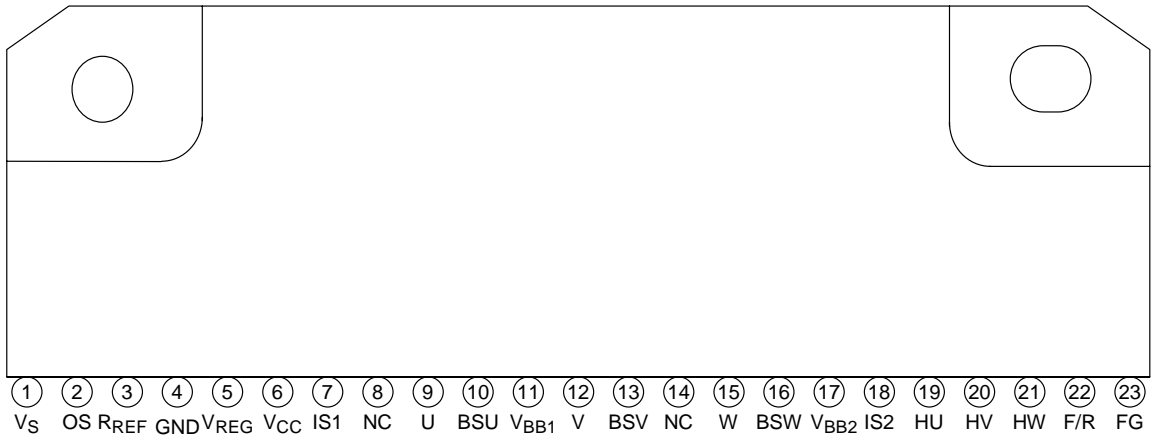

Marking

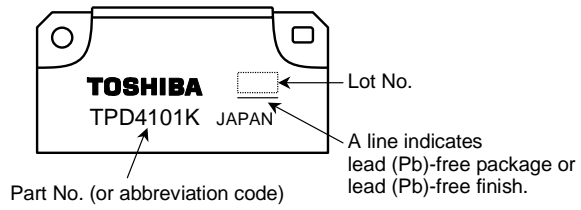

Block Diagram

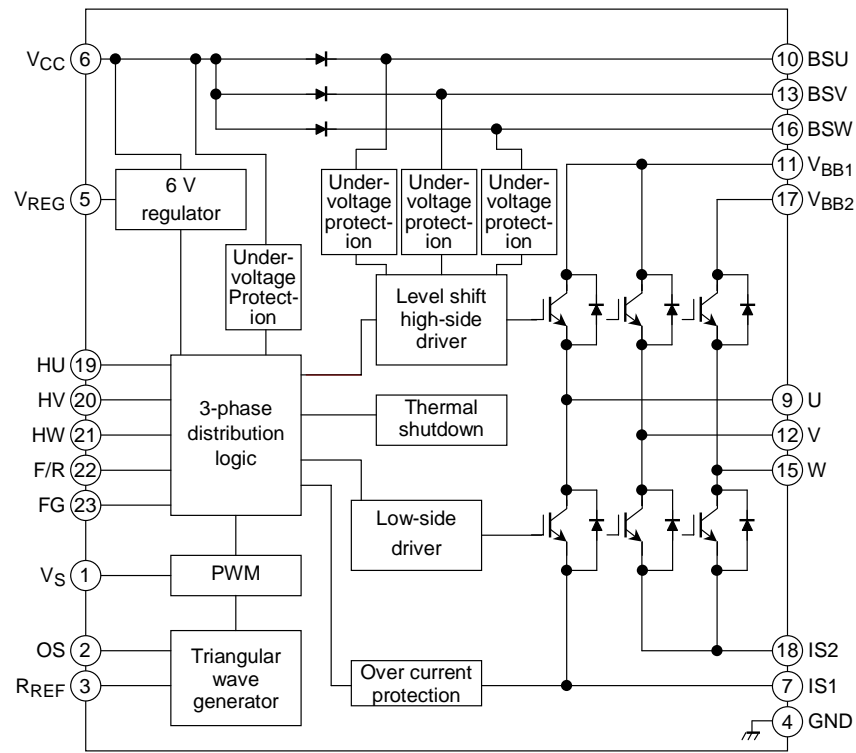

Pin Description

| Pin No. | Symbol | Pin Description |
|---------|------------------|--|
| 1 | V _S | Speed control signal input pin. (PWM reference voltage input pin) |
| 2 | OS | PWM triangular wave oscillation frequency setup pin (Connect a capacitor to this pin.) |
| 3 | R _{REF} | PWM triangular wave oscillation frequency setup pin (Connect a resistor to this pin.) |
| 4 | GND | Ground pin |
| 5 | V _{REG} | 6 V regulator output pin |
| 6 | V _{CC} | Control power supply pin |
| 7 | IS1 | IGBT emitter and FRD anode pin (Connect a current detecting resistor to this pin.) |
| 8 | NC | Unused pin, which is not connected to the chip internally. |
| 9 | U | U-phase output pin |
| 10 | BSU | U-phase bootstrap capacitor connecting pin |
| 11 | V _{BB1} | U and V-phase high-voltage power supply input pin |
| 12 | V | V-phase output pin |
| 13 | BSV | V-phase bootstrap capacitor connecting pin |
| 14 | NC | Unused pin, which is not connected to the chip internally. |
| 15 | W | W-phase output pin |
| 16 | BSW | W-phase bootstrap capacitor connecting pin |
| 17 | V _{BB2} | W-phase high-voltage power supply input pin |
| 18 | IS2 | IGBT emitter/FRD anode pin (Connect a current detecting resistor to this pin.) |
| 19 | HU | U-phase hole IC signal input pin |
| 20 | HV | V-phase hole IC signal input pin |
| 21 | HW | W-phase hole IC signal input pin |
| 22 | F/R | Forward/reverse select input pin |
| 23 | FG | Rotation pulse output pin. (open drain) |

Equivalent Circuit of Input Pins

Internal circuit diagram of HU, HV, HW, F/R input pins

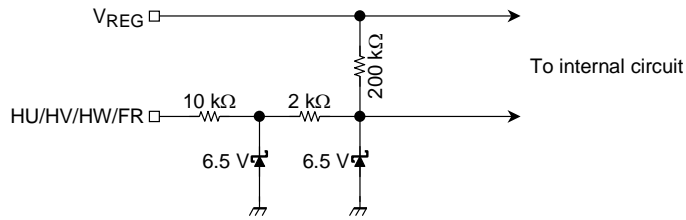

Internal circuit diagram of VS pin

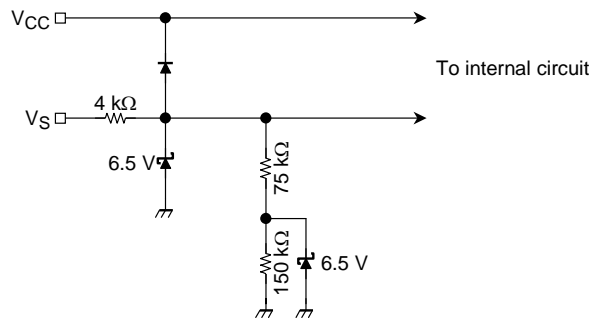

Internal circuit diagram of FG pin

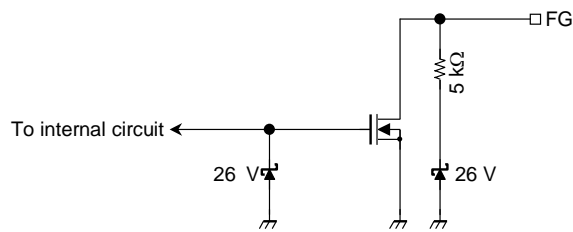

Internal circuit diagram of IS pin

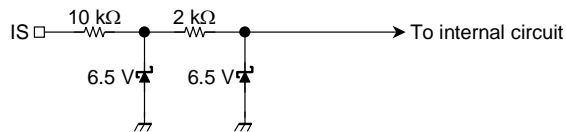

Timing Chart

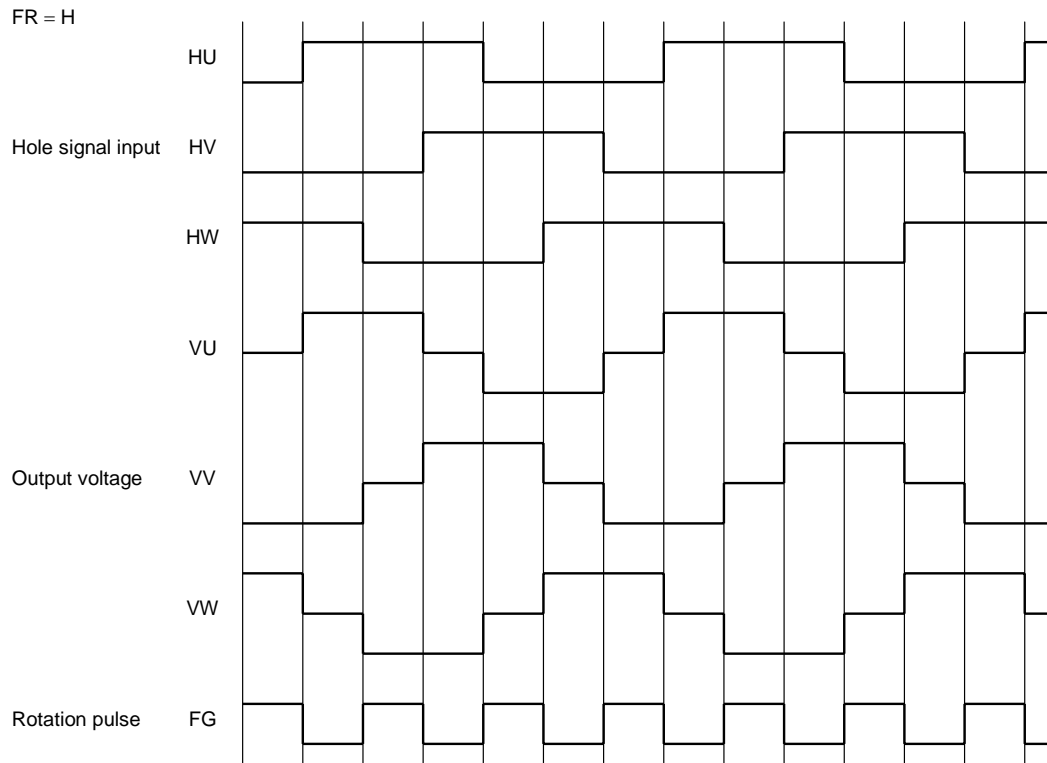

Truth Table

| FR | Hole Signal Input | | | U Phase | | V Phase | | W Phase | | FG |
|----|-------------------|----|----|-----------|-----------|-----------|-----------|-----------|-----------|----|
| | HU | HV | HW | Upper Arm | Lower Arm | Upper Arm | Lower Arm | Upper Arm | Lower Arm | |
| H | H | L | H | ON | OFF | OFF | ON | OFF | OFF | L |
| H | H | L | L | ON | OFF | OFF | OFF | OFF | ON | H |
| H | H | H | L | OFF | OFF | ON | OFF | OFF | ON | L |
| H | L | H | L | OFF | ON | ON | OFF | OFF | OFF | H |
| H | L | H | H | OFF | ON | OFF | OFF | ON | OFF | L |
| H | L | L | H | OFF | OFF | OFF | ON | ON | OFF | H |
| L | H | L | H | OFF | ON | ON | OFF | OFF | OFF | H |
| L | H | L | L | OFF | ON | OFF | OFF | ON | OFF | L |
| L | H | H | L | OFF | OFF | OFF | ON | ON | OFF | H |
| L | L | H | L | ON | OFF | OFF | ON | OFF | OFF | L |
| L | L | H | H | ON | OFF | OFF | OFF | OFF | ON | H |
| L | L | L | H | OFF | OFF | ON | OFF | OFF | ON | L |
| * | L | L | L | OFF | OFF | OFF | OFF | OFF | OFF | L |
| * | H | H | H | OFF | OFF | OFF | OFF | OFF | OFF | L |

Absolute Maximum Ratings (Ta = 25°C)

| Characteristics | Symbol | Rating | Unit |
|----------------------------------|-------------------|--------------------------------|------------------|
| Power supply voltage | V _{BB} | 250 | V |
| | V _{CC} | 20 | V |
| Output current (DC) | I _{out} | 1 | A |
| Output current (pulse) | I _{out} | 1.8 | A |
| Input voltage (except VS) | V _{IN} | -0.5 to V _{REG} + 0.5 | V |
| Input voltage (only VS) | V _{VS} | 8.2 | V |
| V _{REG} current | I _{REG} | 50 | mA |
| Power dissipation (Ta = 25°C) | P _C | 4 | W |
| Power dissipation (Tc = 25°C) | P _C | 20 | W |
| Operating junction temperature | T _{jopr} | -20 to 135 | °C |
| Junction temperature | T _j | 150 | °C |
| Storage temperature | T _{stg} | -55 to 150 | °C |
| Lead-heat sink isolation voltage | V _{hs} | 1000 (1 min) | V _{rms} |

If the IC is erroneously connected to 200 VAC power supply, it can withstand a voltage of up to 315 V for 1 min under the condition of V_S < 1.1 V.

Electrical Characteristics (Ta = 25°C)

| Characteristics | Symbol | Test Condition | Min | Typ. | Max | Unit |
|---|-----------------------|---|------|------|------|------|
| Operating power supply voltage | V _{BB} | — | 50 | — | 185 | V |
| | V _{CC} | — | 13.5 | 15 | 17.5 | |
| Current dissipation | I _{BB} | V _{BB} = 185 V Duty cycle = 0% | — | 0.1 | 0.5 | mA |
| | I _{CC} | V _{CC} = 15 V Duty cycle = 0% | — | 1.8 | 10 | |
| | I _{BS (ON)} | V _{BS} = 15 V, high side ON | — | 355 | 470 | μA |
| | I _{BS (OFF)} | V _{BS} = 15 V, high side OFF | — | 315 | 415 | |
| Input voltage | V _{IH} | V _{IN} = H | 3.5 | — | — | V |
| | V _{IL} | V _{IN} = L | — | — | 1.5 | |
| Input current | I _{IH} | V _{IN} = V _{REG} | — | — | 100 | μA |
| | I _{IL} | V _{IN} = 0 V | — | — | 100 | |
| Output saturation voltage | V _{CEsatH} | V _{CC} = 15 V, I _C = 0.5 A | — | 2.3 | 3.0 | V |
| | V _{CEsatL} | V _{CC} = 15 V, I _C = 0.5 A | — | 2.3 | 3.0 | |
| FRD forward voltage | V _{FH} | I _F = 0.5 A, high side | — | 1.3 | 2.1 | V |
| | V _{FL} | I _F = 0.5 A, low side | — | 1.2 | 1.8 | |
| BSD forward voltage | V _{F (BSD)} | I _F = 500 μA | — | 0.8 | 1.2 | V |
| PWM ON-duty cycle | PWMMIN | — | 0 | — | — | % |
| | PWMMAX | — | — | — | 100 | |
| PWM ON-duty cycle, 0% | V _{Vs0%} | PWM = 0% | 1.7 | 2.1 | 2.5 | V |
| PWM ON-duty cycle, 100% | V _{Vs100%} | PWM = 100% | 4.9 | 5.4 | 6.1 | V |
| PWM ON-duty voltage range | V _{VsW} | V _{Vs100%} - V _{Vs0%} | 2.8 | 3.3 | 3.8 | V |
| Output all-OFF voltage | V _{VsOFF} | Output all OFF | 1.1 | 1.3 | 1.5 | V |
| Regulator voltage | V _{REG} | V _{CC} = 15 V, I _O = 30 mA | 5 | 6 | 7 | V |
| Speed control voltage range | V _S | — | 0 | — | 6.5 | V |
| FG output saturation voltage | V _{FGsat} | V _{CC} = 15 V, I _{FG} = 20 mA | — | — | 0.5 | V |
| Current control voltage | V _R | — | 0.45 | 0.5 | 0.55 | V |
| Thermal shutdown temperature | TSD | — | 150 | 165 | 200 | °C |
| Thermal shutdown hysteresis | ΔTSD | — | — | 20 | — | °C |
| V _{CC} under voltage protection | V _{CCUVD} | — | 10 | 11 | 12 | V |
| V _{CC} under voltage protection recovery | V _{CCUVR} | — | 10.5 | 11.5 | 12.5 | V |
| V _{BS} under voltage protection | V _{BSUVD} | — | 9 | 10 | 11 | V |
| V _{BS} under voltage protection recovery | V _{BSUVR} | — | 9.5 | 10.5 | 11.5 | V |
| Refresh operating ON voltage | T _{RFON} | Refresh operation | 1.1 | 1.3 | 1.5 | V |
| Refresh operating OFF voltage | T _{RFOFF} | Refresh operation OFF | 3.1 | 3.8 | 4.6 | V |
| Triangular wave frequency | f _c | R = 27 kΩ, C = 1000 pF | 16.5 | 20 | 25 | kHz |
| Output on delay time | t _{on} | V _{BB} = 141 V, V _{CC} = 15 V, I _C = 0.5 A | — | 2.0 | 3 | μs |
| Output off delay time | t _{off} | V _{BB} = 141 V, V _{CC} = 15 V, I _C = 0.5 A | — | 1.5 | 3 | μs |
| FRD reverse recovery time | t _{rr} | V _{BB} = 141 V, V _{CC} = 15 V, I _C = 0.5 A | — | 200 | — | ns |

Application Circuit Example

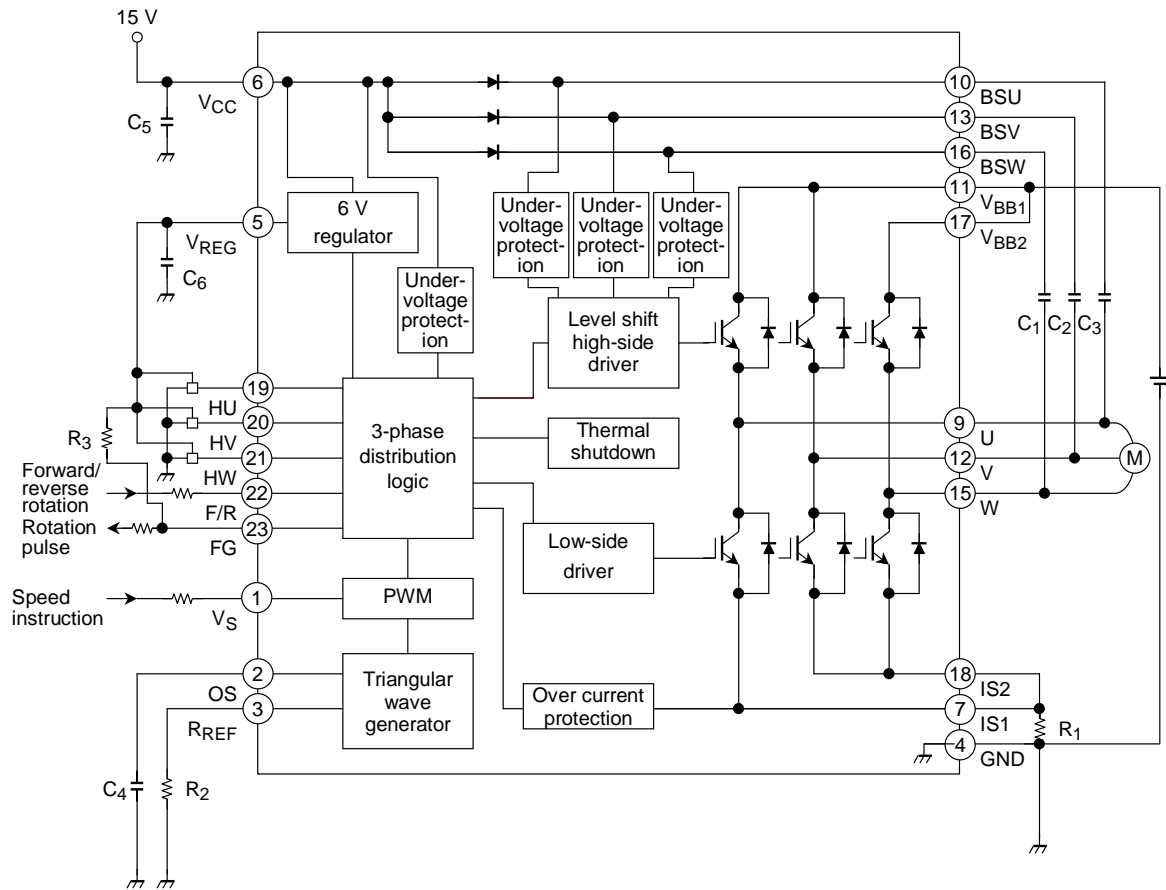

External Parts

Standard external parts are shown in the following table.

| Part | Recommended Value | Purpose | Remarks |
|--|-------------------|---|----------|
| C ₁ , C ₂ , C ₃ | 25 V/2.2 μF | Bootstrap capacitor | (Note 1) |
| R ₁ | 0.62 Ω ± 1% (1 W) | Current detection | (Note 2) |
| C ₄ | 10 V/1000 pF ± 5% | PWM frequency setup | (Note 3) |
| R ₂ | 27 kΩ ± 5% | PWM frequency setup | (Note 3) |
| C ₅ | 25 V/10 μF | Control power supply stability | (Note 4) |
| C ₆ | 10 V/0.1 μF | V _{REG} power supply stability | (Note 4) |
| R ₃ | 5.1 kΩ | FG pin pull-up resistor | (Note 5) |

Note 1: The required bootstrap capacitance value varies according to the motor drive conditions. The IC can operate at above the V_{BS} undervoltage level, however, it is recommended that the capacitor voltage be greater than or equal to 13.5 V to keep the power dissipation small. The capacitor is biased by V_{CC} and must be sufficiently derated for it.

Note 2: The following formula shows the detection current: $I_D = V_R \div R_{IS}$ (V_R = 0.5 V typ.)
Do not exceed a detection current of 1 A when using the IC.

Note 3: With the combination of C_{os} and R_{REF} shown in the table, the PWM frequency is around 20 kHz. The IC intrinsic error factor is around 10%.

The PWM frequency is broadly expressed by the following formula. (In this case, the stray capacitance of the printed circuit board needs to be considered.)

$$f_{PWM} = 0.65 \div \{C_{os} \times (R_{REF} + 4.25 \text{ k}\Omega)\} \quad [\text{Hz}]$$

R_{REF} creates the reference current of the PWM triangular wave charge/discharge circuit. If R_{REF} is set too small it exceeds the current capacity of the IC internal circuits and the triangular wave distorts. Set R_{REF} to at least 9 kΩ.

Note 4: When using the IC, some adjustment is required in accordance with the use environment. When mounting, place as close to the base of the IC leads as possible to improve the noise elimination.

Note 5: The FG pin is open drain. Note that when the FG pin is connected to a power supply with a voltage higher than or equal to the V_{CC}, a protection circuit is triggered so that the current flows continuously. If not using the FG pin, connect to the GND.

Note 6: If noise is detected on the Hall signal pin, add a CR filter.
(recommended 0.1-μF capacitor and 1-kΩ resistor)

Handling precautions

- (1) When switching the power supply to the circuit on/off, ensure that V_S < V_{VSOFF} (all IGBT outputs off). At that time, either the V_{CC} or the V_{BB} can be turned on/off first. Note that if the power supply is switched off as described above, the IC may be destroyed if the current regeneration route to the V_{BB} power supply is blocked when the V_{BB} line is disconnected by a relay or similar while the motor is still running.
- (2) The IC has a forward/reverse rotation control pin (F/R). To change the rotation direction, switch the F/R pin after ensuring that the motor has stopped and that the V_S voltage is lower than or equal to 1.1 V. If the F/R pin is switched while the motor is rotating, the following malfunctions may occur.
 - A shoot-through current may flow between the upper arm and lower arm in the output stage (IGBT) at that moment when the motor is switched.
 - An over current may flow into the area where the over current protection circuit cannot detect it.
- (3) The IS pin connecting the current detection resistor is connected to a comparator in the IC and also functions as a sensor pin for detecting over current. As a result, over voltage caused by a surge voltage, for example, may destroy the circuit. Accordingly, use care in handling the IC and guard against surge voltage in its application environment.
- (4) The triangular wave oscillator circuit, with externally connected C_{OS} and R_{REF}, charges and discharges minute amounts of current. Therefore, subjecting the IC to noise when mounting it on the board may distort the triangular wave or cause malfunction. To avoid this, attach external parts to the base of the IC leads or isolate them from any tracks or wiring that carry large current.
- (5) The PWM of this IC is controlled by the on/off state of the high-side IGBT.

Description of Protection Functions

(1) Over current protection

The IC incorporates the over current protection circuit to protect itself against over current at startup or when a motor is locked. This protection function detects voltage generated in the current detection resistor connected to the IS pin. When this voltage exceeds $V_R = 0.5$ V (typ.), the high-side IGBT output, which is on, temporarily shuts down after a mask period (approx. 2.3 ms), preventing any additional current from flowing to the IC. The next PWM ON signal releases the shutdown state.

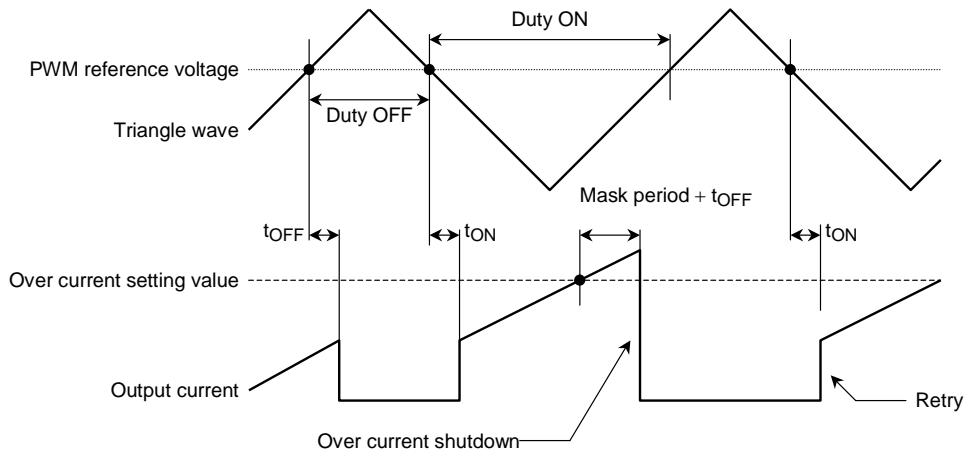

(2) Under voltage protection

The IC incorporates the under voltage protection circuit to prevent the IGBT from operating in unsaturated mode when the VCC voltage or the VBS voltage drops.

When the VCC power supply falls to the IC internal setting ($VCCUVD = 11$ V typ.), all IGBT outputs shut down regardless of the input. This protection function has hysteresis. When the $VCCUVR (= 11.5$ V typ.) reaches 0.5 V higher than the shutdown voltage, the IC is automatically restored and the IGBT is turned on again by the input signal.

When the VBS supply voltage drops ($VBSUVD = 10$ V typ.), the high-side IGBT output shuts down. When the $VBSUVR (= 10.5$ V typ.) reaches 0.5 V higher than the shutdown voltage, the IGBT is turned on again by the input signal.

(3) Thermal shutdown

The IC incorporates the thermal shutdown circuit to protect itself against the abnormal state when its temperature rises excessively.

When the temperature of this chip rises due to external causes or internal heat generation and the internal setting TSD reaches 165°C, all IGBT outputs shut down regardless of the input. This protection function has hysteresis ($\Delta TSD = 20^\circ\text{C}$ typ.). When the chip temperature falls to $TSD - \Delta TSD$, the chip is automatically restored and the IGBT is turned on again by the input signal.

Because the chip contains just one temperature detection location, when the chip heats up due to the IGBT, for example, the differences in distance from the detection location in the IGBT (the source of the heat) cause differences in the time taken for shutdown to occur. Therefore, the temperature of the chip may rise higher than the thermal shutdown temperature when the circuit started to operate.

Description of Bootstrap Capacitor Charging and Its Capacitance

The IC uses bootstrapping for the power supply for high-side drivers. The bootstrap capacitor is charged by turning on the low-side IGBT of the same arm (approximately 1/5 of PWM cycle) while the high-side IGBT controlled by PWM is off. (For example, to drive at 20 kHz, it takes approximately 10 ms per cycle to charge the capacitor.) When the V_S voltage exceeds 3.8 V (55% duty), the low-side IGBT is continuously in the off state. This is because when the PWM on-duty becomes larger, the arm is short-circuited while the low-side IGBT is on. Even in this state, because PWM control is being performed on the high-side IGBT, the regenerative current of the diode flows to the low-side FRD of the same arm, and bootstrap capacitor is charged. Note that when the on-duty is 100%, diode regenerative current does not flow; thus, the bootstrap capacitor is not charged.

When driving a motor at 100 % duty cycle, take the voltage drop at 100% duty (see the figure below) into consideration to determine the capacitance of the bootstrap capacitor.

Capacitance of the bootstrap capacitor = Consumption current (max) of the high-side driver × Maximum drive time / $(V_{CC} - V_F(\text{BSD}) + V_F(\text{FRD}) - 13.5)$ [F]

$V_F(\text{BSD})$: Bootstrap diode forward voltage

$V_F(\text{FRD})$: Flywheel diode forward voltage

Attention should also be given to the effects of aging and temperature change on the capacitor.

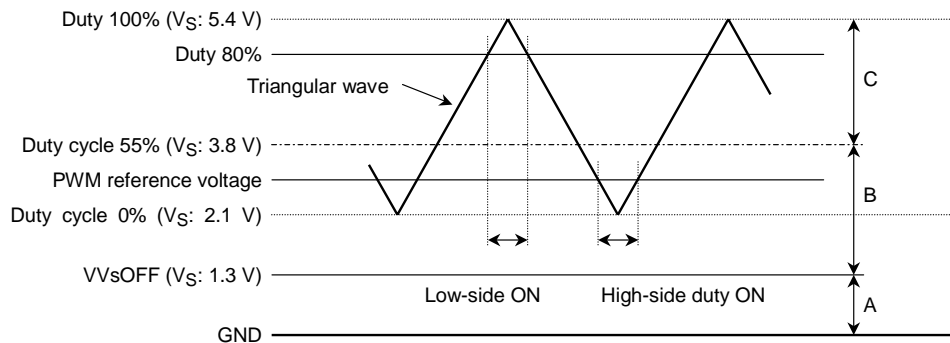

| V_S Range | IGBT Operation |
|-------------|---|
| A | Both high- and low-side OFF. |
| B | Charging range. Low-side IGBT turns on at the phase when the high-side IGBT turns on in the timing chart. |
| C | No charging range. High-side at PWM; low-side continues according to the timing chart. |

Safe Operating Area

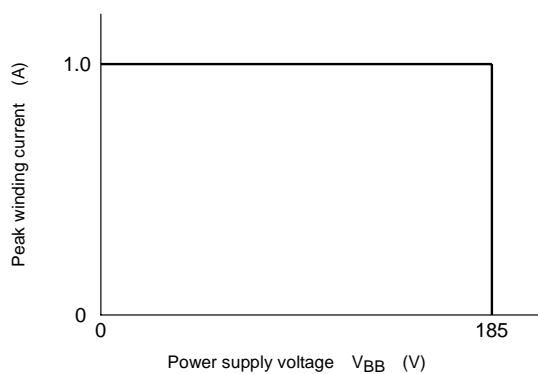

Figure 1 SOA at $T_j = 135^\circ\text{C}$

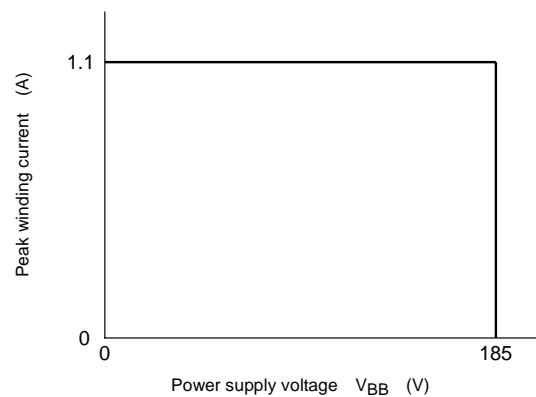
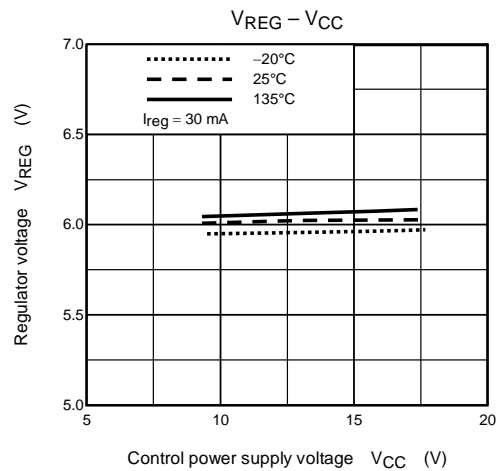
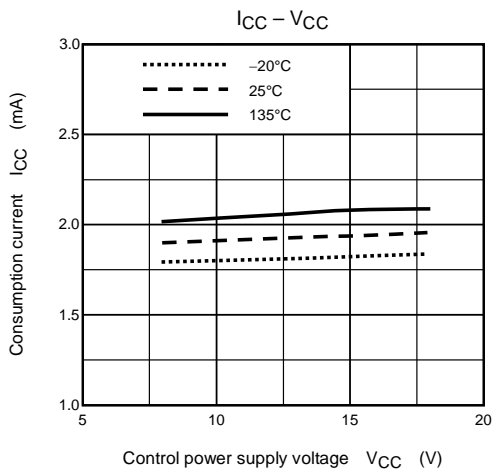
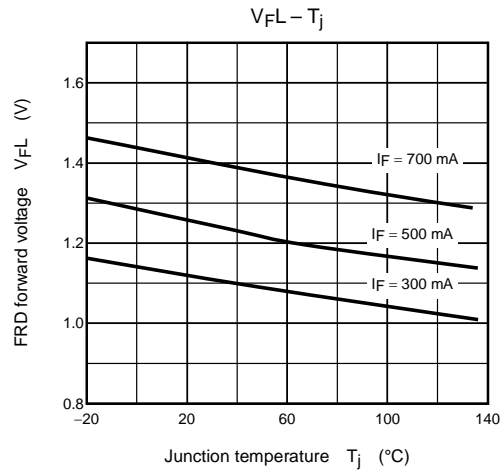
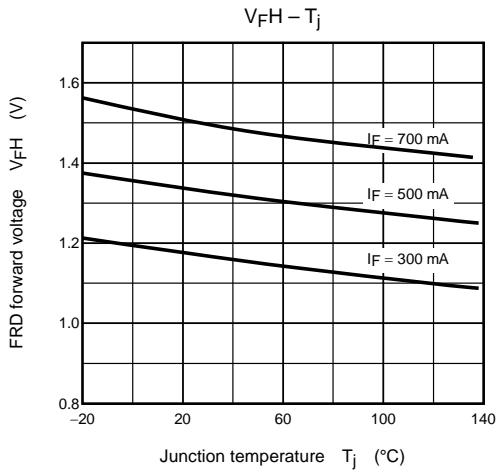
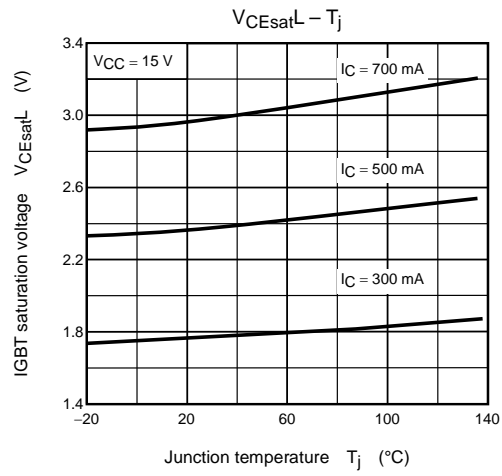
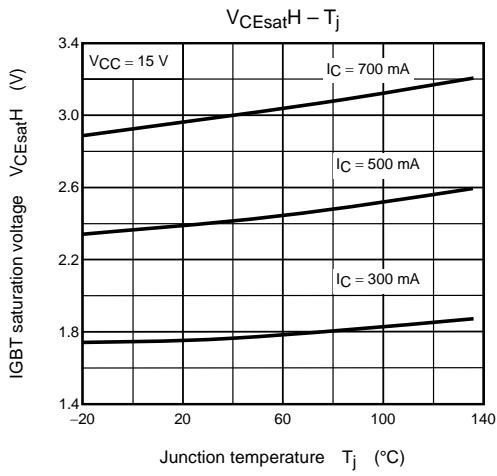
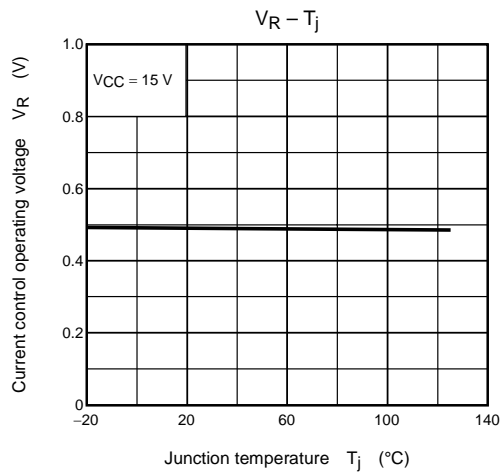
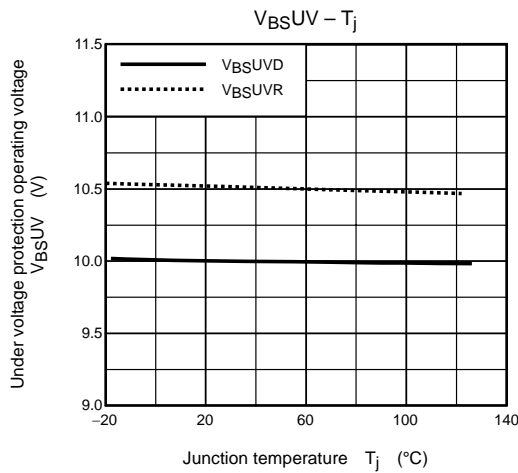
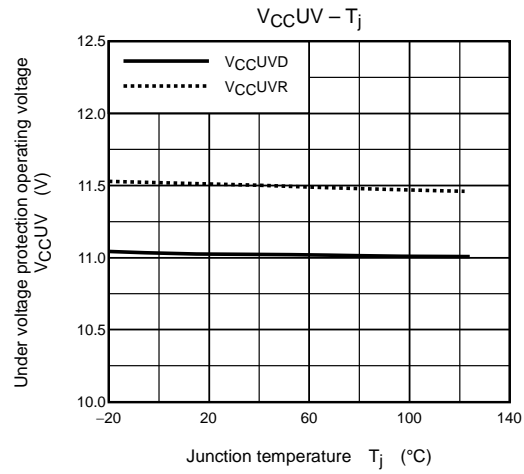
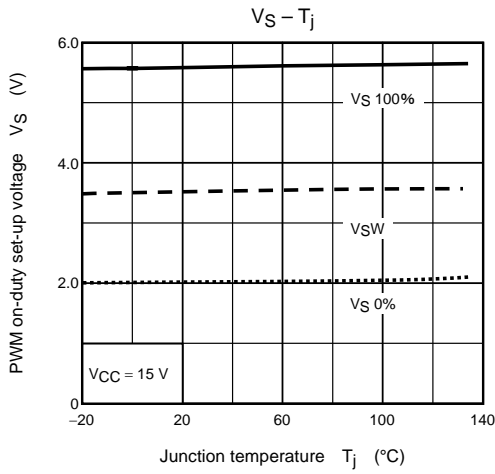
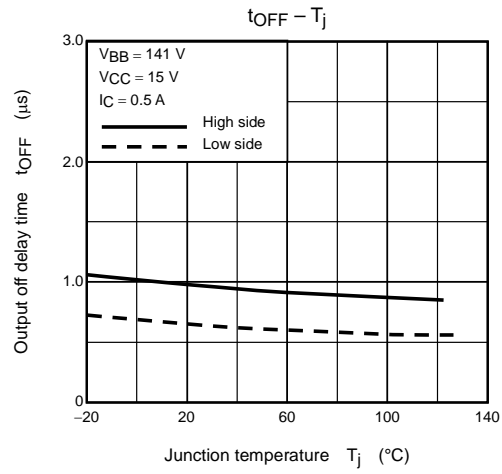
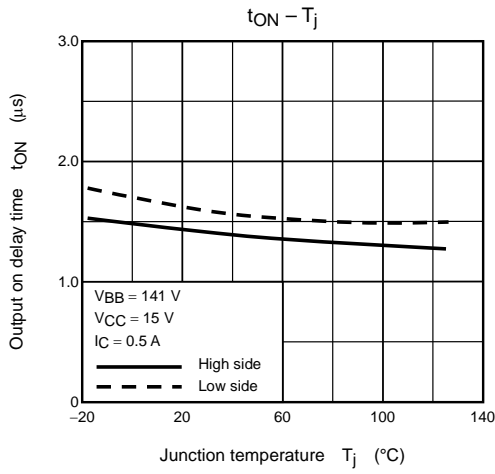

Figure 2 SOA at $T_c = 95^\circ\text{C}$

Note 1: The above safe operating areas are at $T_j = 135^\circ\text{C}$ (Figure 1) and $T_c = 95^\circ\text{C}$ (Figure 2). If the temperature exceeds these, the safe operation areas are reduced in size.

Note 2: The above safe operating areas include the over current protection operation area.





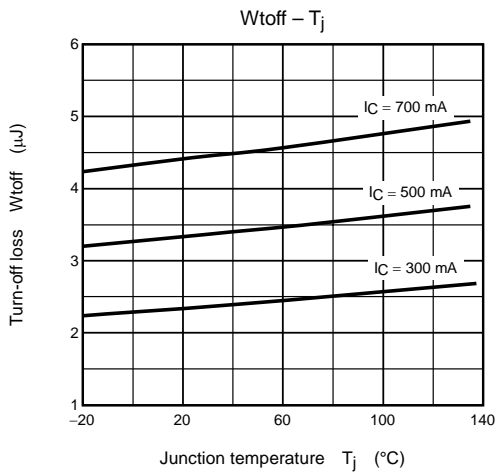
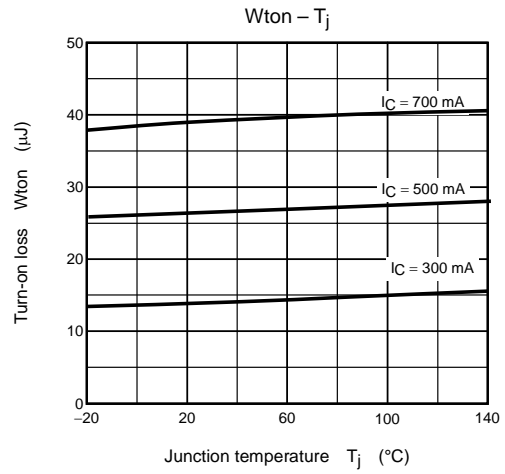
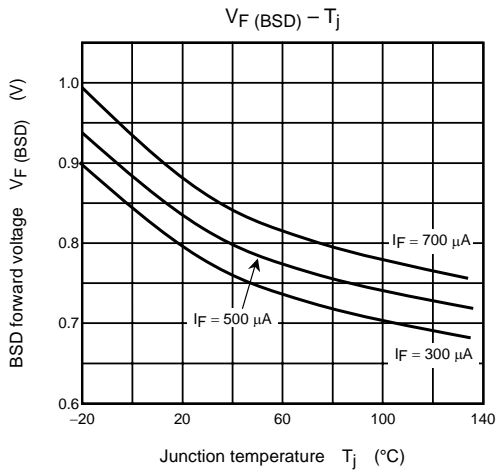
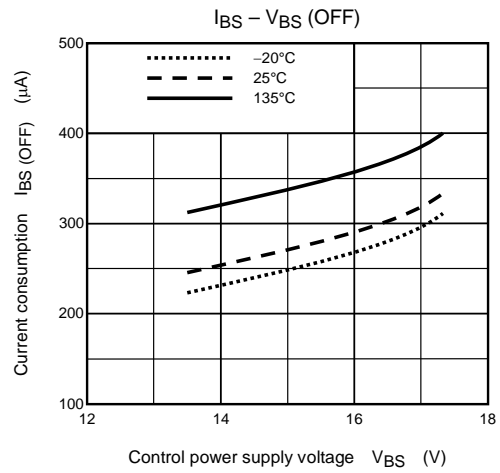
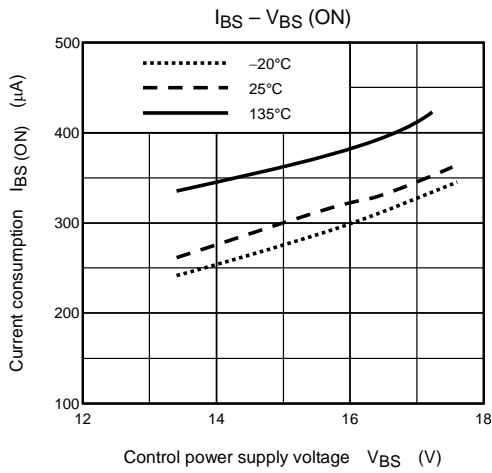

Test Circuits

IGBT Saturation Voltage (U-phase low side)

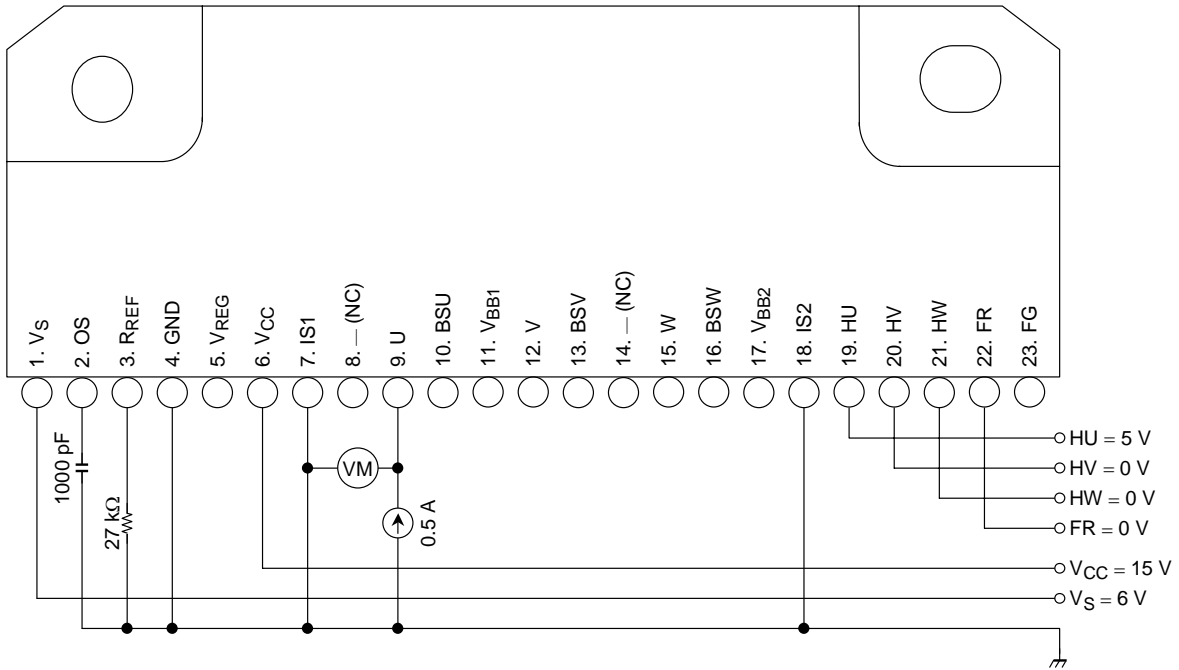

FRD Forward Voltage (U-phase low side)

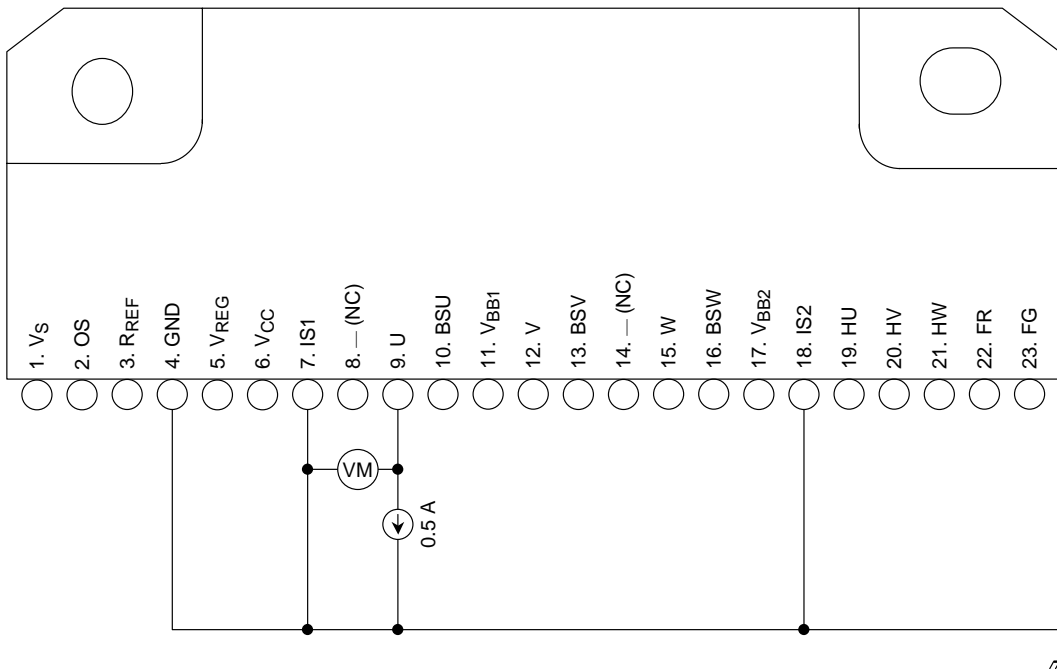

V_{CC} Current Dissipation

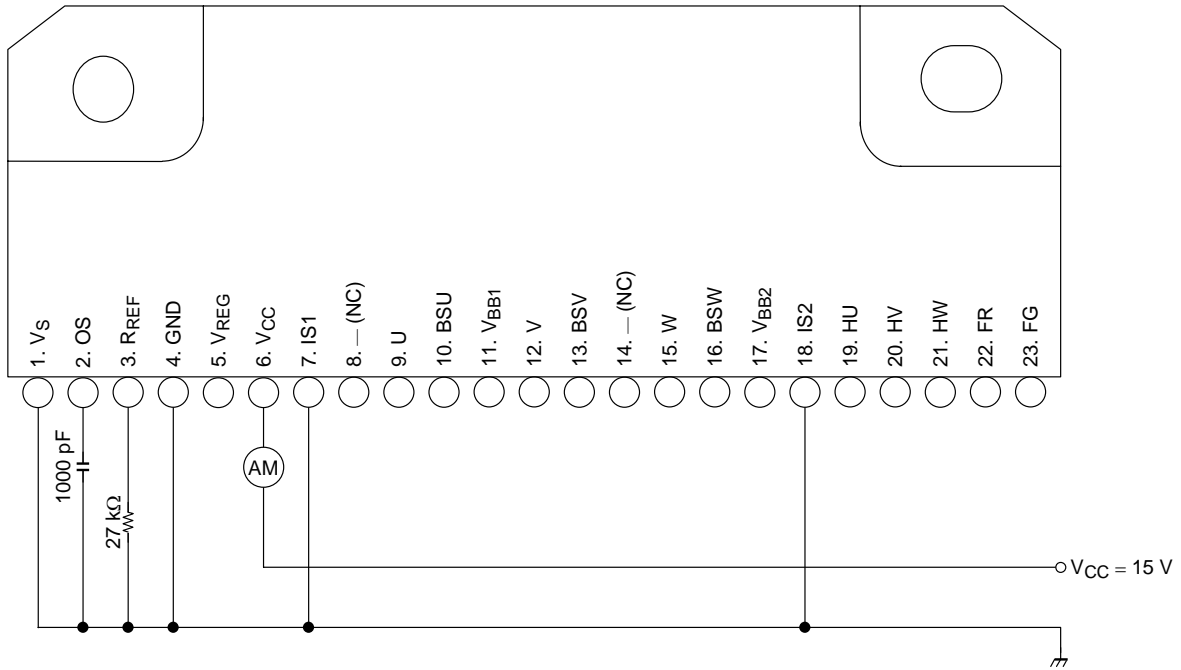

Regulator Voltage

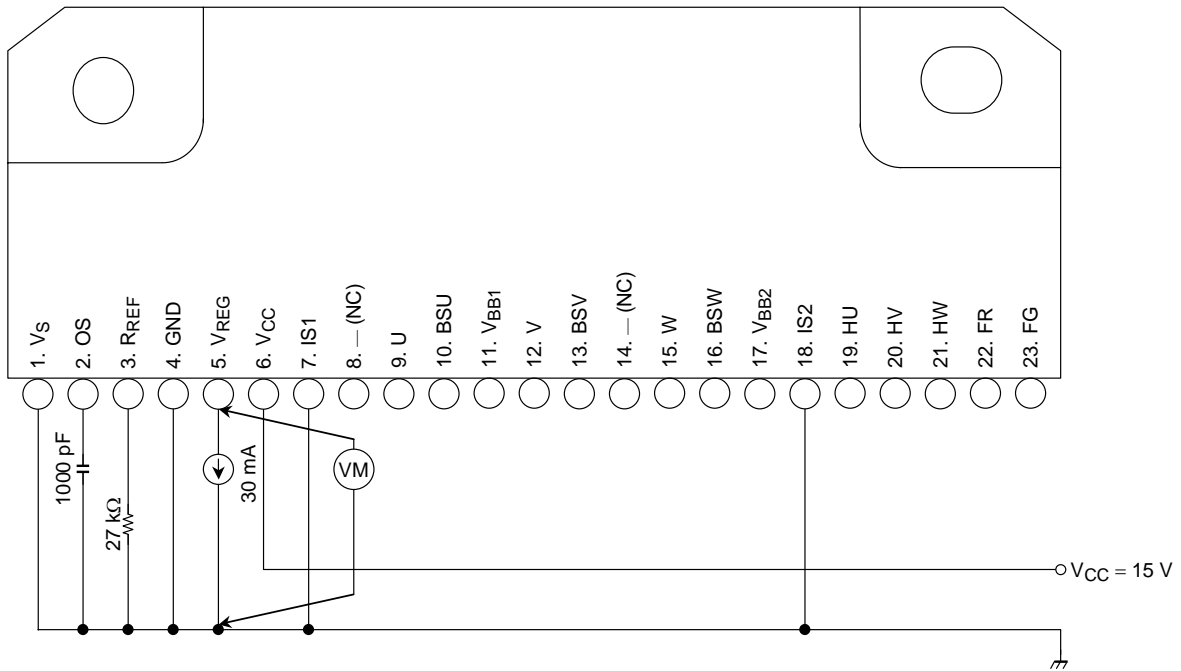

Output ON/OFF Delay Time (U-phase low side)

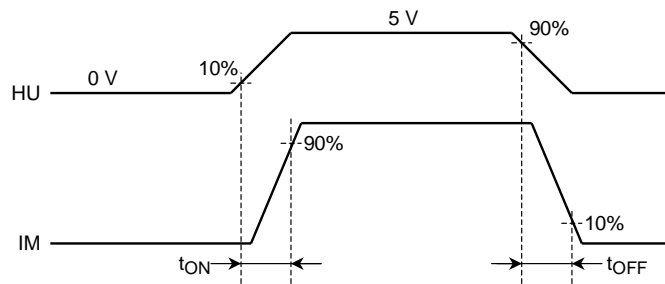
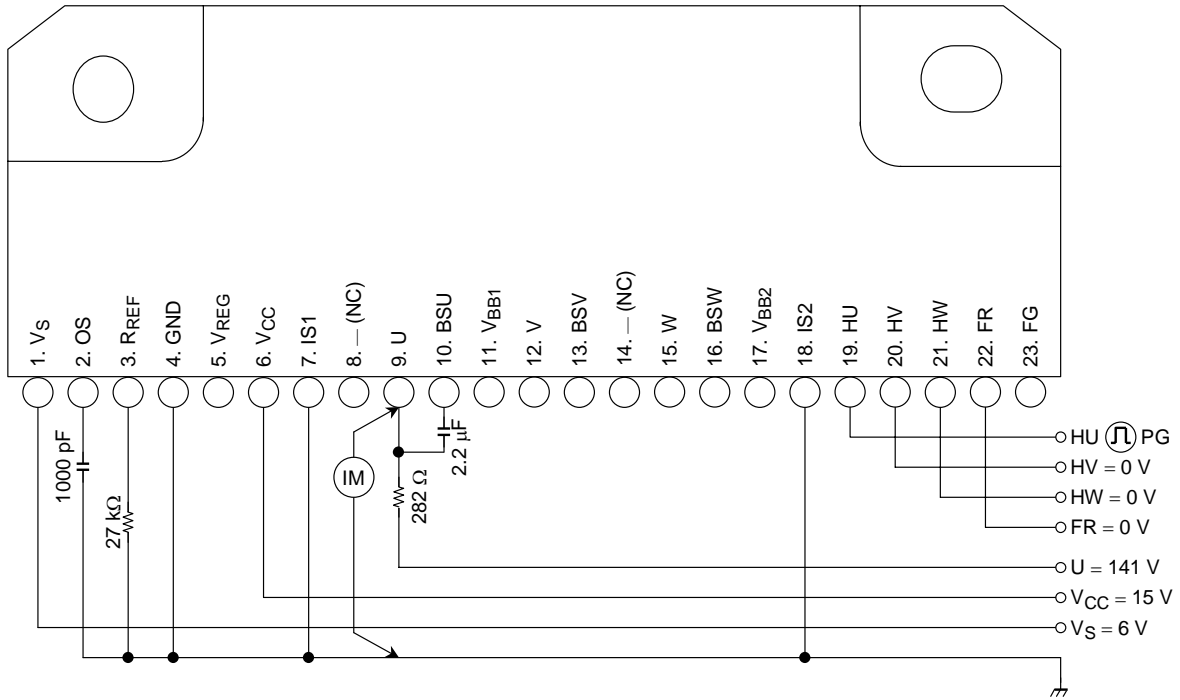

PWM ON-duty Setup Voltage (U-phase high side)

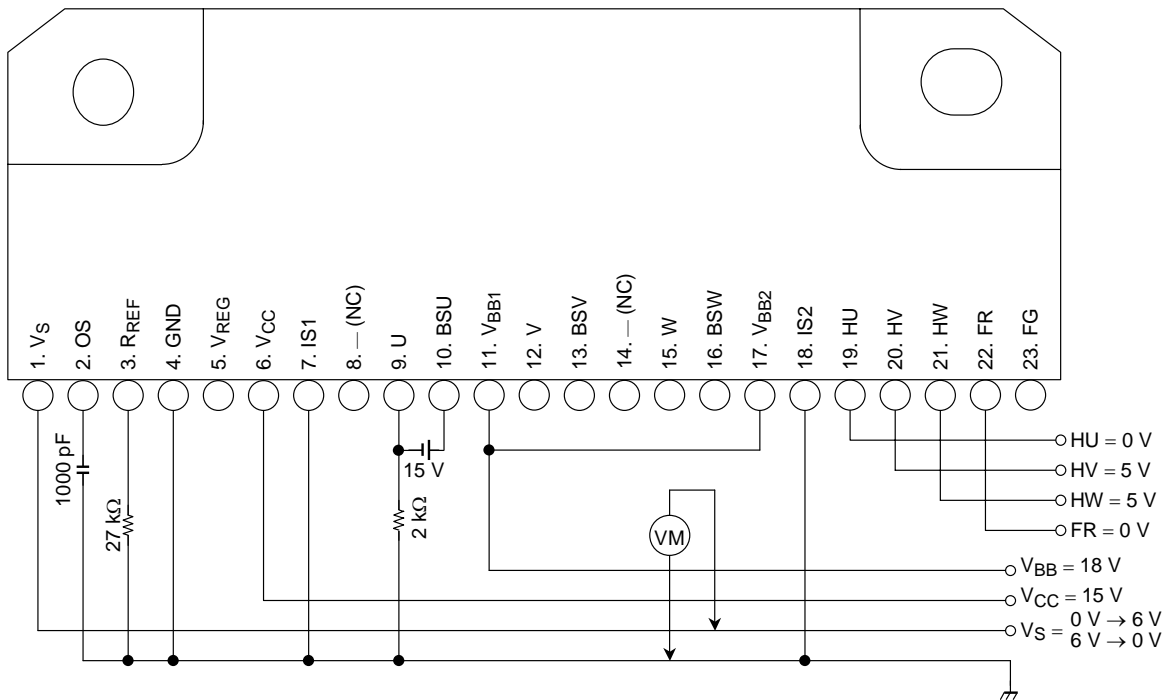

Note: Sweeps the VS pin voltage to increase and monitors the U pin.
 When output is turned off from on, the PWM = 0%. When output is full on, the PWM = 100%.

V_{CC} Under Voltage Protection Operation/Recovery Voltage (U-phase low side)

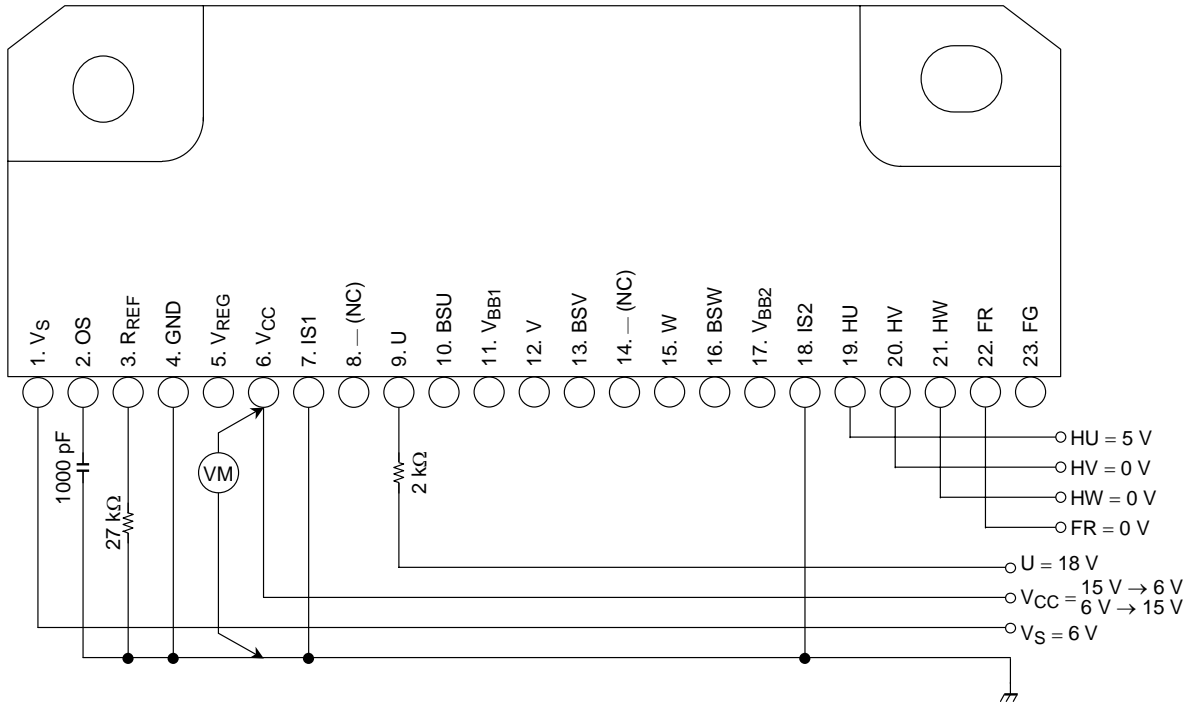

Note: Sweeps the V_{CC} pin voltage from 15 V to decrease and monitors the U pin voltage. The V_{CC} pin voltage when output is off defines the under voltage protection operating voltage. Also sweeps from 6 V to increase. The V_{CC} pin voltage when output is on defines the under voltage protection recovery voltage.

V_{BS} Under Voltage Protection Operation/Recovery Voltage (U-phase high side)

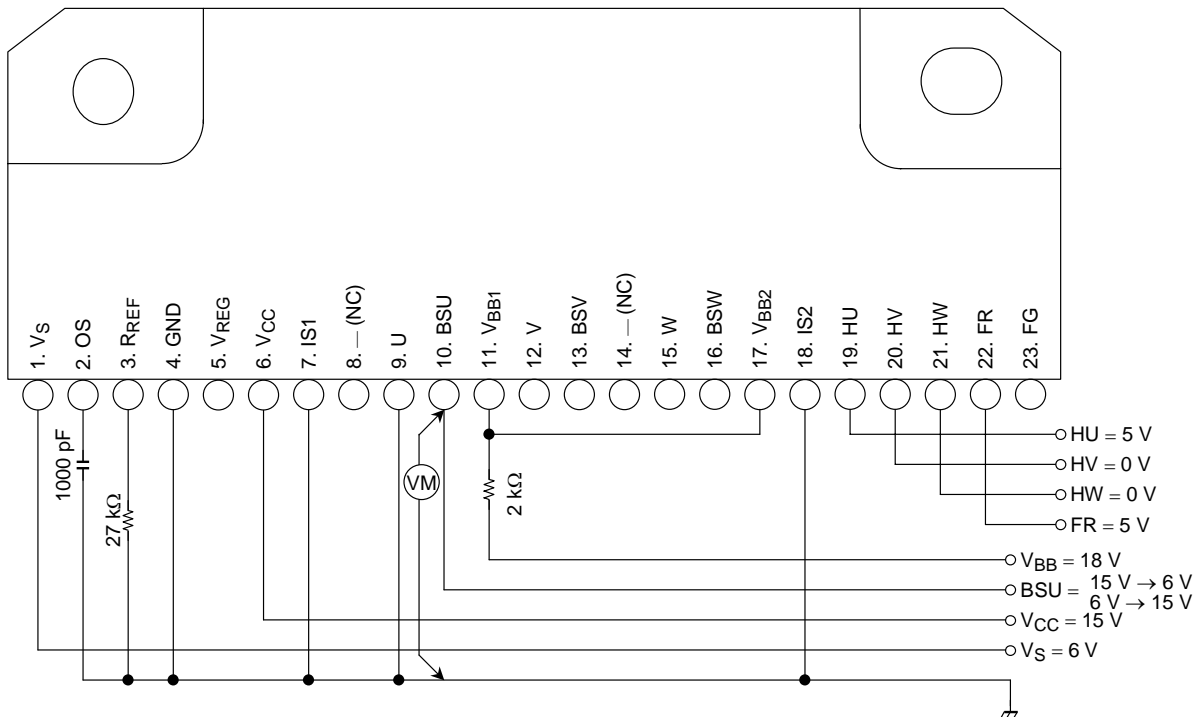

Note: Sweeps the BSU pin voltage from 15 V to decrease and monitors the V_{BB} pin voltage. The BSU pin voltage when output is off defines the under voltage protection operating voltage. Also sweeps the BSU pin voltage from 6 V to increase and change the VS voltage at 6 V → 0 V → 6V. The BSU pin voltage when output is on defines the under voltage protection recovery voltage.

Current Control Operating Voltage (U-phase high side)

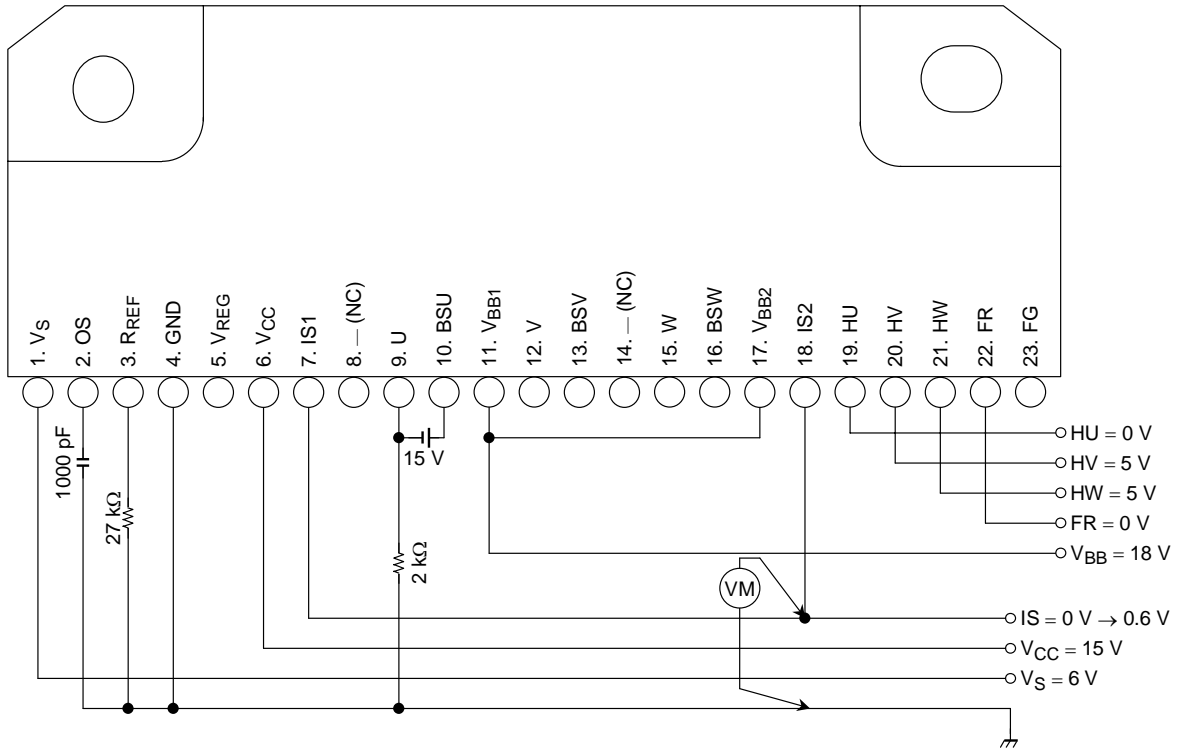

Note: Sweeps the IS pin voltage to increase and monitors the U pin voltage.
 The IS pin voltage when output is off defines the current control operating voltage.

V_{BS} Current Consumption (U-phase high side)

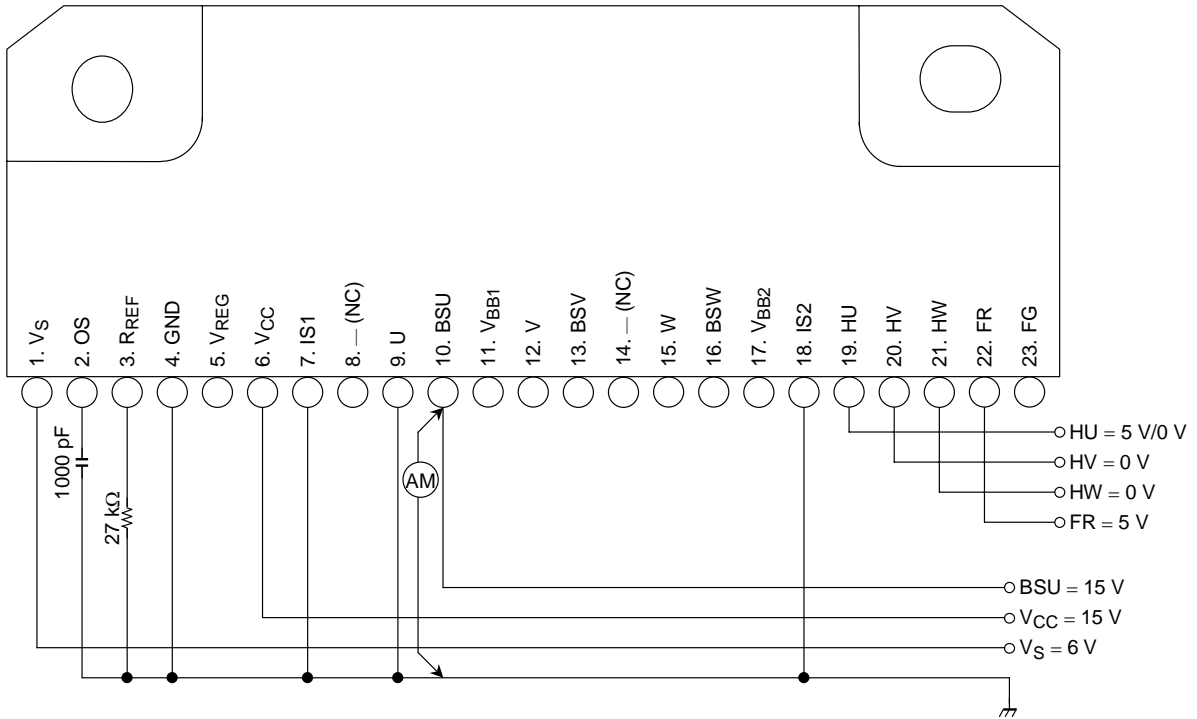

BSD Forward Voltage (U-phase)

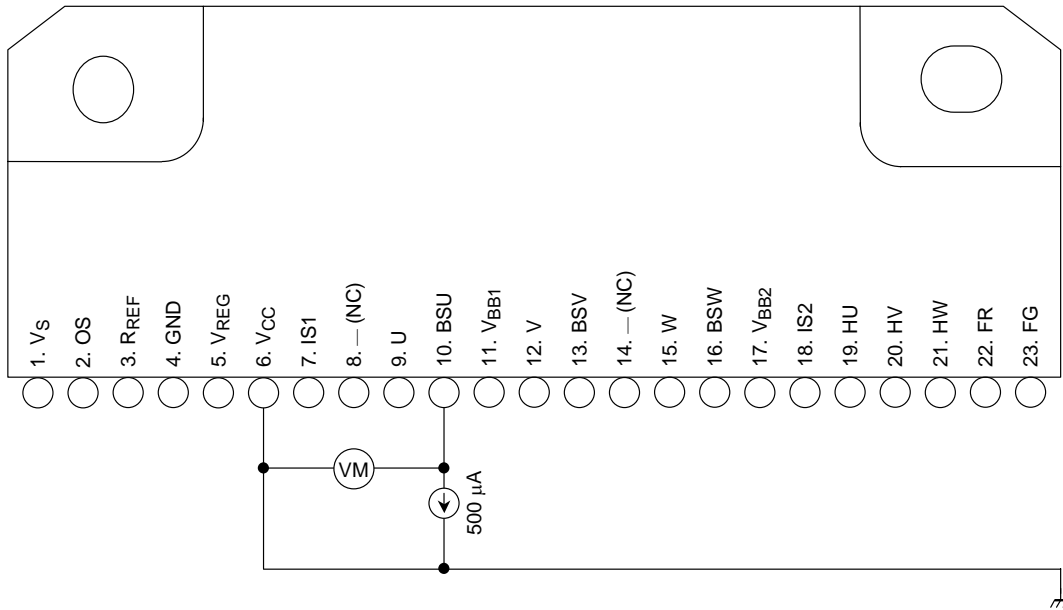

Turn-On/Off Loss (low-side IGBT + high-side FRD)

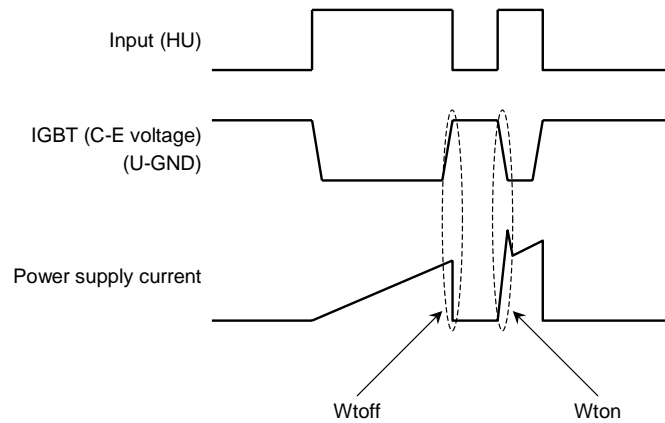
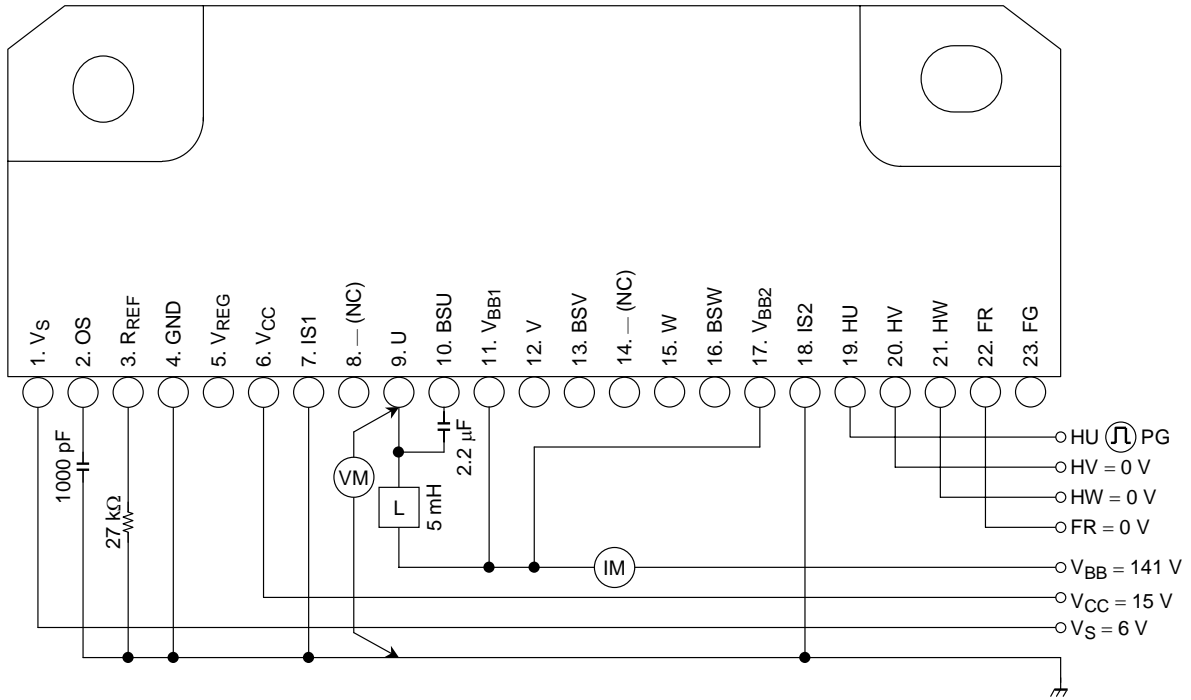

Package Dimensions

HZIP23-P-1.27F

Unit: mm

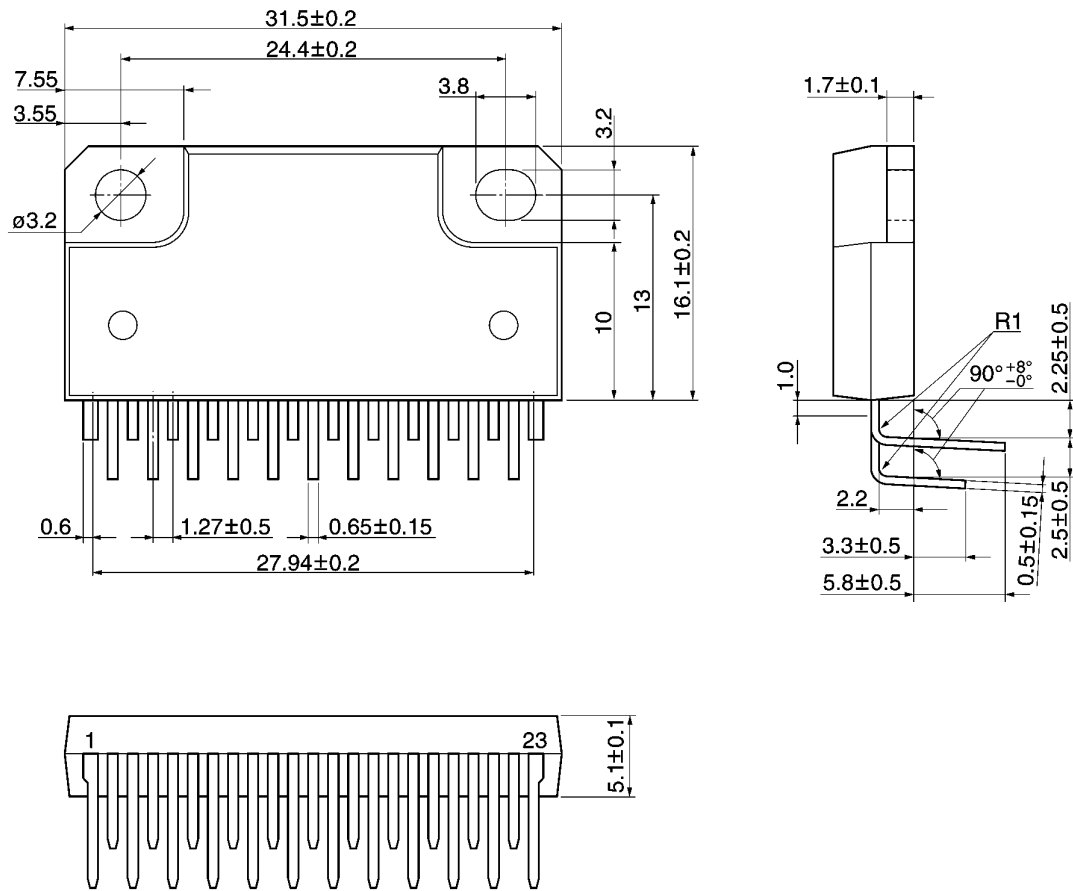

Weight: 6.1 g (typ.)

Package Dimensions

HZIP23-P-1.27H

Unit: mm

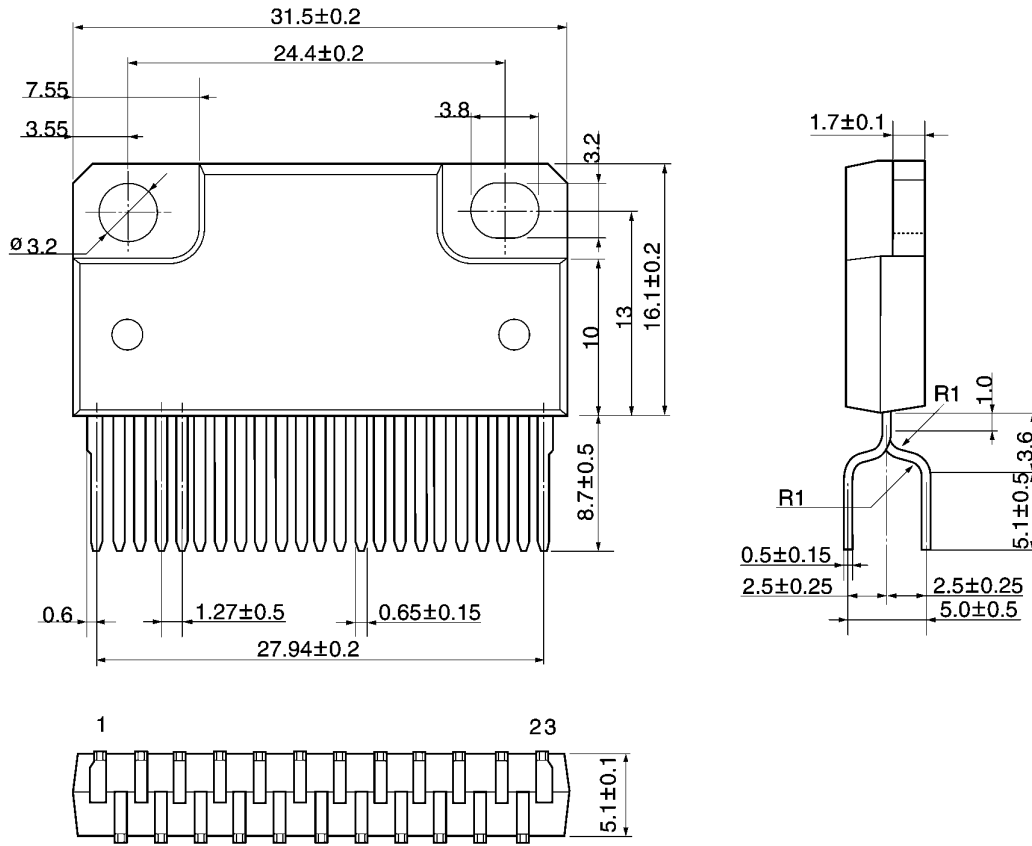

Weight: 6.1 g (typ.)

RESTRICTIONS ON PRODUCT USE

030619EBA

- The information contained herein is subject to change without notice.
- The information contained herein is presented only as a guide for the applications of our products. No responsibility is assumed by TOSHIBA for any infringements of patents or other rights of the third parties which may result from its use. No license is granted by implication or otherwise under any patent or patent rights of TOSHIBA or others.
- TOSHIBA is continually working to improve the quality and reliability of its products. Nevertheless, semiconductor devices in general can malfunction or fail due to their inherent electrical sensitivity and vulnerability to physical stress. It is the responsibility of the buyer, when utilizing TOSHIBA products, to comply with the standards of safety in making a safe design for the entire system, and to avoid situations in which a malfunction or failure of such TOSHIBA products could cause loss of human life, bodily injury or damage to property.
In developing your designs, please ensure that TOSHIBA products are used within specified operating ranges as set forth in the most recent TOSHIBA products specifications. Also, please keep in mind the precautions and conditions set forth in the "Handling Guide for Semiconductor Devices," or "TOSHIBA Semiconductor Reliability Handbook" etc..
- The TOSHIBA products listed in this document are intended for usage in general electronics applications (computer, personal equipment, office equipment, measuring equipment, industrial robotics, domestic appliances, etc.). These TOSHIBA products are neither intended nor warranted for usage in equipment that requires extraordinarily high quality and/or reliability or a malfunction or failure of which may cause loss of human life or bodily injury ("Unintended Usage"). Unintended Usage include atomic energy control instruments, airplane or spaceship instruments, transportation instruments, traffic signal instruments, combustion control instruments, medical instruments, all types of safety devices, etc.. Unintended Usage of TOSHIBA products listed in this document shall be made at the customer's own risk.
- The products described in this document are subject to the foreign exchange and foreign trade laws.
- TOSHIBA products should not be embedded to the downstream products which are prohibited to be produced and sold, under any law and regulations.