

DRAWING MADE IN THIRD ANGLE PROJECTION
 THIS DRAWING IS UNPUBLISHED. RELEASED FOR PUBLICATION
 © COPYRIGHT 19 BY AMP INCORPORATED, HARRISBURG, PA. ALL INTERNATIONAL RIGHTS RESERVED. AMP PRODUCTS MAY BE COVERED BY U.S. AND FOREIGN PATENTS AND/OR PATENTS PENDING.

LOC	DIST	P	F	ZONE	LTR	DESCRIPTION	DATE	APPD
AD	39				D	EC 0010-1601-95	2/20/97	GD
					E	REV PER 0010-1696-95	3/31/97	GD
					F	REV PER 0010-0085-96	3/31/97	GD

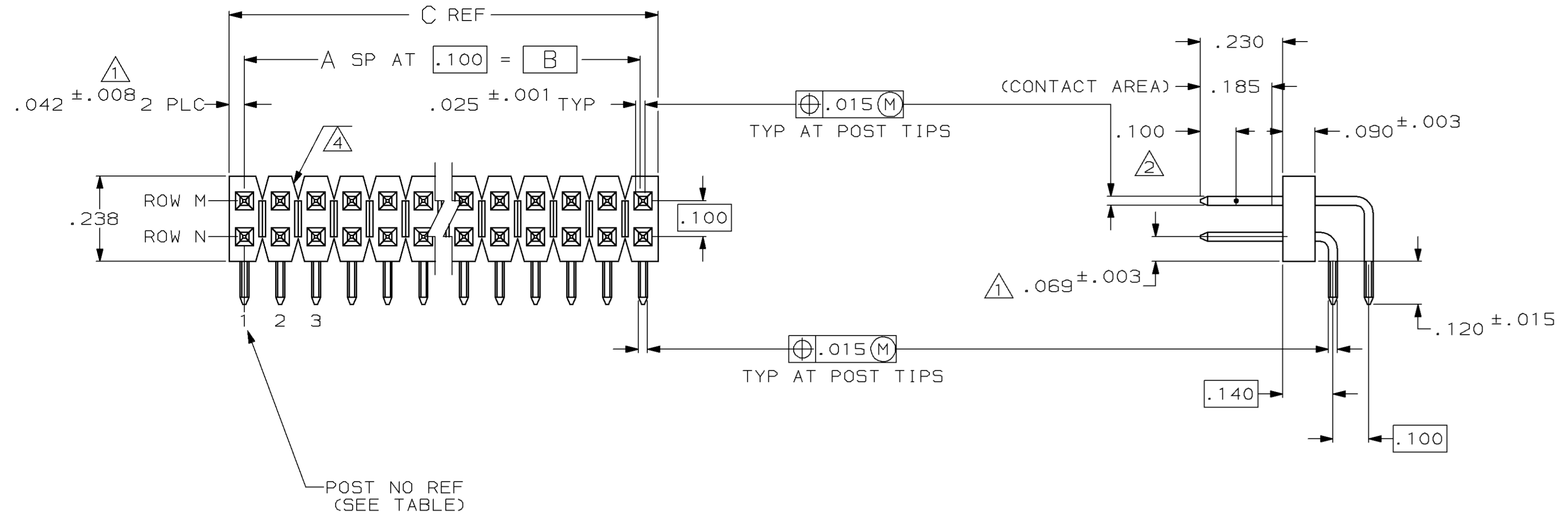

- △ THE NOTED DIMENSIONS APPLY AT THE INTERSECTION OF THE POST AND THE HOUSING
- △ POINT OF MEASUREMENT FOR PLATING THICKNESS
- 3. FOR ACTIVE POSITION SIZES 4 AND ABOVE, POSTS WILL BE SELECTIVELY SWAGED TO PROVIDE CONNECTOR RETENTION TO THE PC BOARD UNTIL SOLDERED. FOR POSITION SIZE 2, POSTS WILL BE KINKED. (SEE TABLE FOR RETENTION FEATURE LOCATION)
- △ BREAKAWAY NOTCH ANGLE CAN BE ORIENTED TO THE RIGHT (AS SHOWN) OR TO THE LEFT

1, 2, 39, 40	1, 2, 39, 40	3.984	3.900	39	80	2-104353-0
1, 2, 29, 30	1, 2, 29, 30	2.984	2.900	29	60	1-104353-9
1, 2, 24, 25	1, 2, 24, 25	2.484	2.400	24	50	1-104353-8
1, 2, 19, 20	1, 2, 19, 20	1.984	1.900	19	40	1-104353-7
1, 2, 16, 17	1, 2, 16, 17	1.684	1.600	16	34	1-104353-6
1, 2, 14, 15	1, 2, 14, 15	1.484	1.400	14	30	1-104353-5
1, 2, 13, 14	1, 2, 13, 14	1.384	1.300	13	28	1-104353-4
1, 2, 12, 13	1, 2, 12, 13	1.284	1.200	12	26	1-104353-3
1, 2, 11, 12	1, 2, 11, 12	1.184	1.100	11	24	1-104353-2
1, 2, 10, 11	1, 2, 10, 11	1.084	1.000	10	22	1-104353-1
1, 2, 9, 10	1, 2, 9, 10	.984	.900	9	20	1-104353-0
1, 2, 8, 9	1, 2, 8, 9	.884	.800	8	18	104353-9
1, 2, 7, 8	1, 2, 7, 8	.784	.700	7	16	104353-8
1, 2, 6, 7	1, 2, 6, 7	.684	.600	6	14	104353-7
1, 2, 5, 6	1, 2, 5, 6	.584	.500	5	12	104353-6
1, 2, 4, 5	1, 2, 4, 5	.484	.400	4	10	104353-5
1, 2, 3, 4	1, 2, 3, 4	.384	.300	3	8	104353-4
1, 2, 3	1, 2, 3	.284	.200	2	6	104353-3
1, 2	1, 2	.184	.100	1	4	104353-2
1	1	.084	-	-	2	104353-1
OBSOLETE						
ROW N	ROW M					
HOLD-DOWN POST CONFIG LOCATION		C	B	A	NO OF POSN	ASSEMBLY PART NUMBER

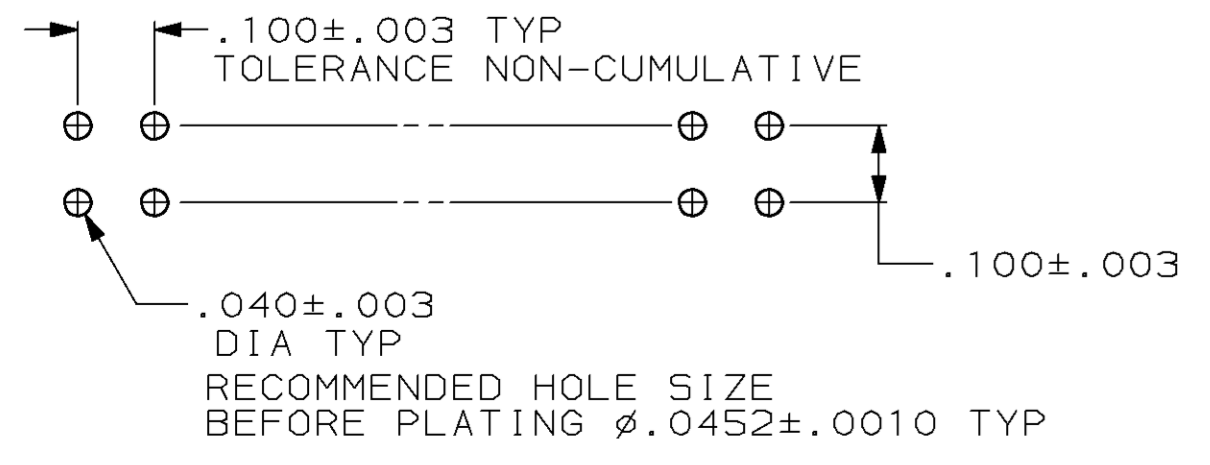

RECOMMENDED HOLE LAYOUT

UNLESS OTHERWISE SPECIFIED DIMENSIONS ARE IN INCHES TOLERANCES ON:	DR 2-4-88 M. PASTAL	AMP INCORPORATED Harrisburg, Pa. 17105
2 PL DEC ±-. 3 PL DEC ±.005 ANGLES ±-	CHK 2-9-88 R. FEIDT	
MATERIAL: HOUSING: FLAME RETARDANT THERMOPLASTIC, COLOR: BLACK	APPD 2-9-88 R. FEIDT	
POSTS: PHOS BRONZE FINISH: POSTS: .000030 GOLD ON THE CONTACT AREA, .000100-.000200 MATTE TIN-LEAD ON THE SOLDER TAIL, ALL OVER .000050 NICKEL	APPD 22-9-88 R. ELICKER PRODUCT SPEC - APPLICATION SPEC - WEIGHT -	
NAME HEADER ASSEMBLY, MOD II, BREAKAWAY, RIGHT ANGLE, DOUBLE ROW, .100X.100C, .025 SQ POSTS WITH HOLD-DOWN CONFIGURATIONS		SIZE D
FSCM NO 00779		DRAWING NO 104353
SCALE 4:1		SHEET 1 OF 1