



## N-Channel Enhancement Mode Field Effect Transistor

### PRODUCT SUMMARY

V <sub>DSS</sub>	I <sub>D</sub>	R <sub>DS(ON)</sub> (mΩ) Typ
33V	24A	5.0 @ V <sub>GS</sub> =10V
		6.5 @ V <sub>GS</sub> =6V

### FEATURES

- Super high dense cell design for low R<sub>DS(ON)</sub>.
- Rugged and reliable.
- Surface Mount Package.
- ESD Protected.

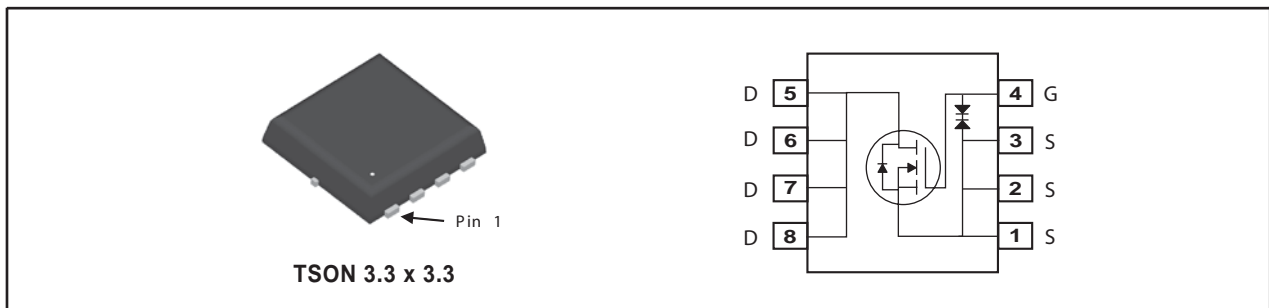

### ABSOLUTE MAXIMUM RATINGS (T<sub>A</sub>=25°C unless otherwise noted)

Symbol	Parameter	Limit	Units
V <sub>DS</sub>	Drain-Source Voltage	33	V
V <sub>GS</sub>	Gate-Source Voltage	±20	V
I <sub>D</sub>	Drain Current-Continuous	24	A
I <sub>DM</sub>	-Pulsed <sup>a</sup>	72	A
P <sub>D</sub>	Maximum Power Dissipation	1.67	W
T <sub>J</sub> , T <sub>STG</sub>	Operating Junction and Storage Temperature Range	-55 to 150	°C

### THERMAL CHARACTERISTICS

R <sub>θJA</sub>	Thermal Resistance, Junction-to-Ambient	75	°C/W
------------------	---	----	------

# SP8009E

Ver 1.5

## ELECTRICAL CHARACTERISTICS (T<sub>A</sub>=25°C unless otherwise noted)

Symbol	Parameter	Conditions	Min	Typ	Max	Units
<b>OFF CHARACTERISTICS</b>						
BV <sub>DSS</sub>	Drain-Source Breakdown Voltage	V <sub>GS</sub> =0V, I <sub>D</sub> =10mA	33			V
BV <sub>DSX</sub>		V <sub>GS</sub> =-20V, I <sub>D</sub> =10mA	10			V
I <sub>DSS</sub>	Zero Gate Voltage Drain Current	V <sub>DS</sub> =33V, V <sub>GS</sub> =0V			10	uA
I <sub>GSS</sub>	Gate-Body Leakage Current	V <sub>GS</sub> = ±20V, V <sub>DS</sub> =0V			±10	uA
<b>ON CHARACTERISTICS</b>						
V <sub>GS(th)</sub>	Gate Threshold Voltage	V <sub>DS</sub> =V <sub>GS</sub> , I <sub>D</sub> =0.2mA	1	1.6	3	V
R <sub>DS(ON)</sub>	Drain-Source On-State Resistance	V <sub>GS</sub> =10V, I <sub>D</sub> =12A		5.0	6.5	m ohm
		V <sub>GS</sub> =6V, I <sub>D</sub> =12A		6.5	9.0	m ohm
<b>DYNAMIC CHARACTERISTICS<sup>b</sup></b>						
C <sub>ISS</sub>	Input Capacitance	V <sub>DS</sub> =10V, V <sub>GS</sub> =0V f=1.0MHz		1670		pF
C <sub>OSS</sub>	Output Capacitance			362		pF
C <sub>RSS</sub>	Reverse Transfer Capacitance			333		pF
<b>SWITCHING CHARACTERISTICS<sup>b</sup></b>						
t <sub>D(ON)</sub>	Turn-On Delay Time	V <sub>DD</sub> =15V I <sub>D</sub> =12A V <sub>GS</sub> =10V R <sub>GEN</sub> = 4.7 ohm		29		ns
t <sub>r</sub>	Rise Time			35		ns
t <sub>D(OFF)</sub>	Turn-Off Delay Time			68		ns
t <sub>f</sub>	Fall Time			17		ns
Q <sub>g</sub>	Total Gate Charge	V <sub>DS</sub> =24V, I <sub>D</sub> =12A, V <sub>GS</sub> =10V		29		nC
Q <sub>gs</sub>	Gate-Source Charge	V <sub>DS</sub> =24V, I <sub>D</sub> =12A, V <sub>GS</sub> =10V		7		nC
Q <sub>gd</sub>	Gate-Drain Charge			8		nC
<b>DRAIN-SOURCE DIODE CHARACTERISTICS AND MAXIMUM RATINGS</b>						
V <sub>SD</sub>	Diode Forward Voltage	V <sub>GS</sub> =0V, I <sub>S</sub> =24A		0.87	1.3	V
<b>Notes</b>						
a.Pulse Test:Pulse Width < 300us, Duty Cycle < 2%.						
b.Guaranteed by design, not subject to production testing.						

Oct,22,2013

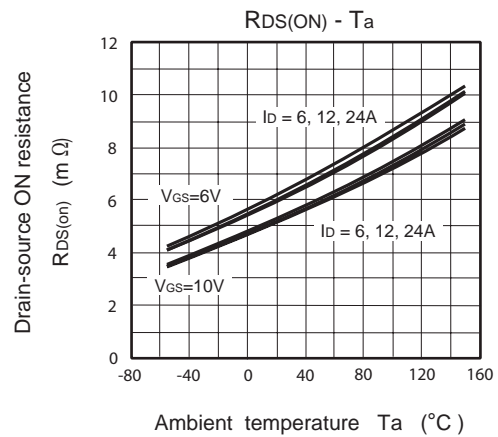
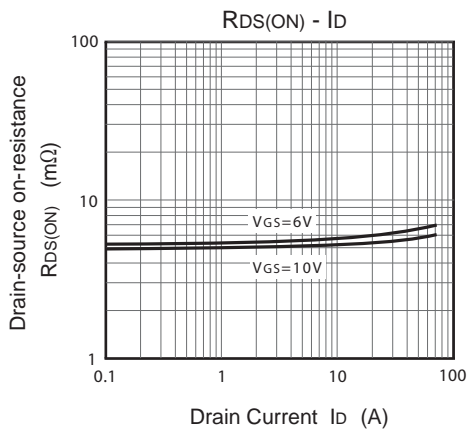
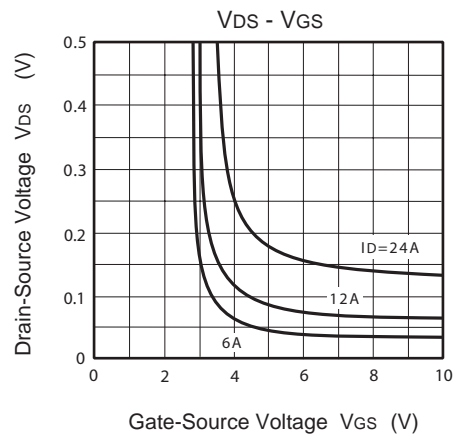
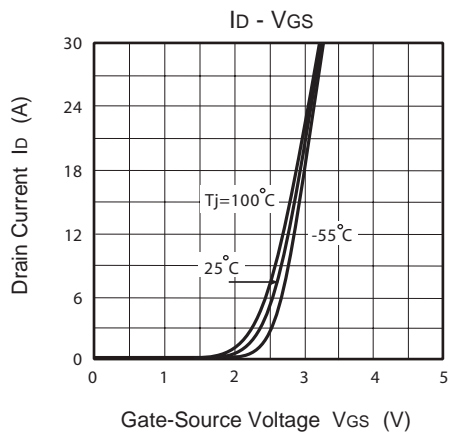
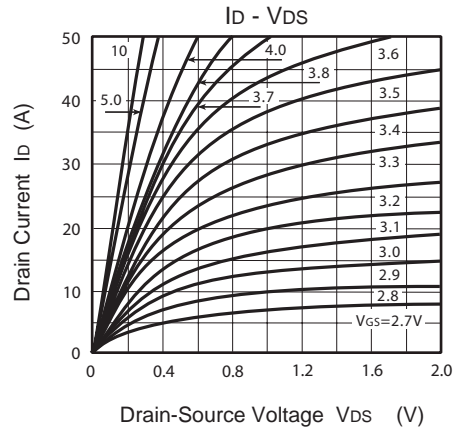
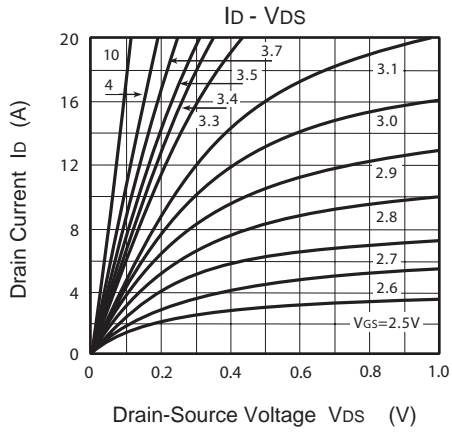

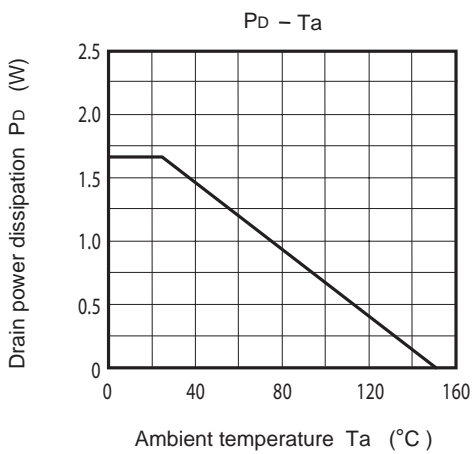
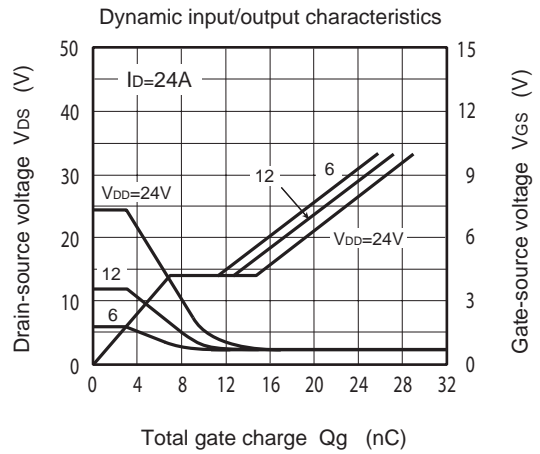
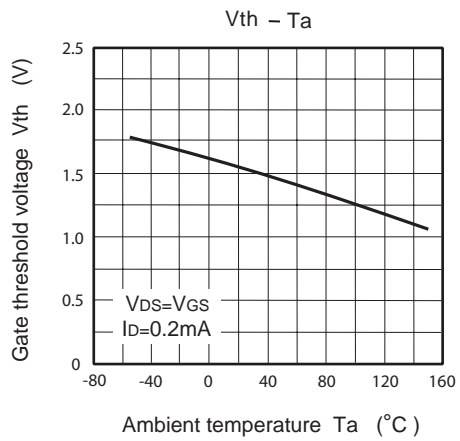
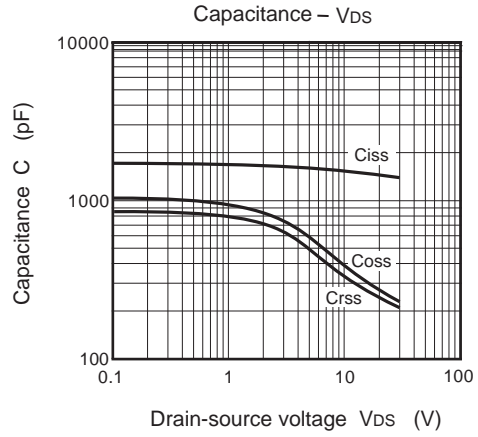
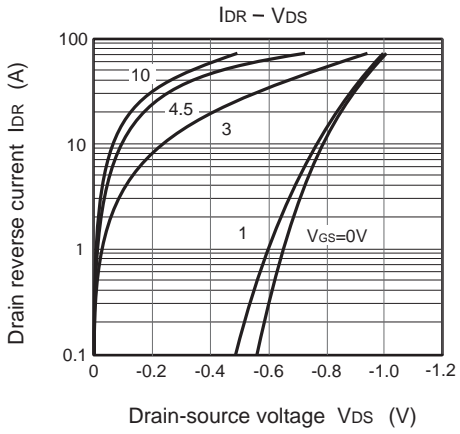

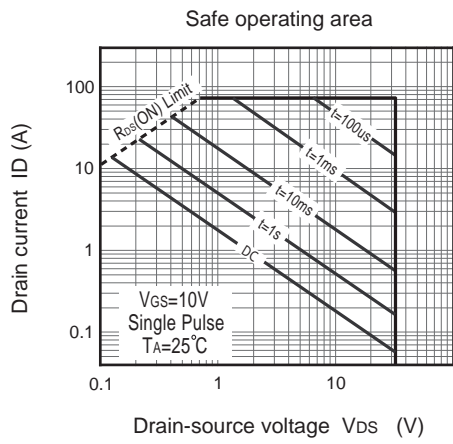
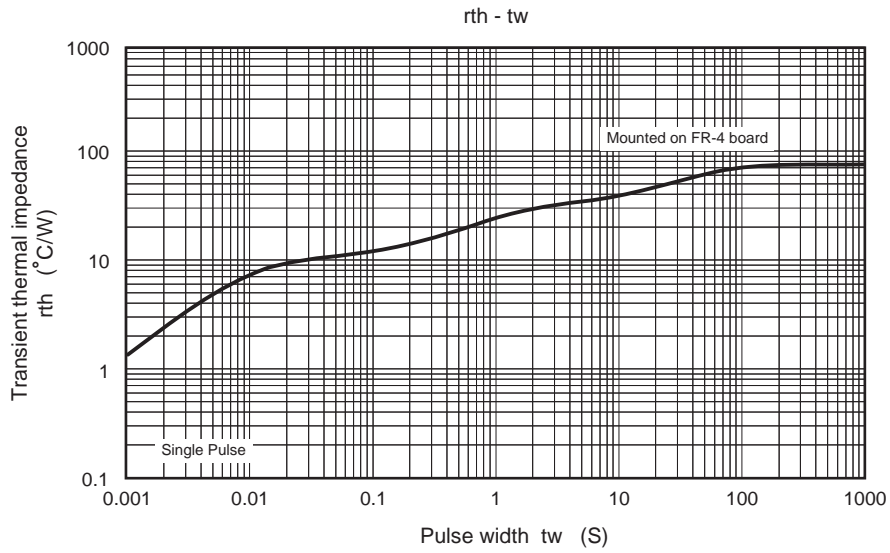

## PACKAGE OUTLINE DIMENSIONS

### TSON 3.3 x 3.3

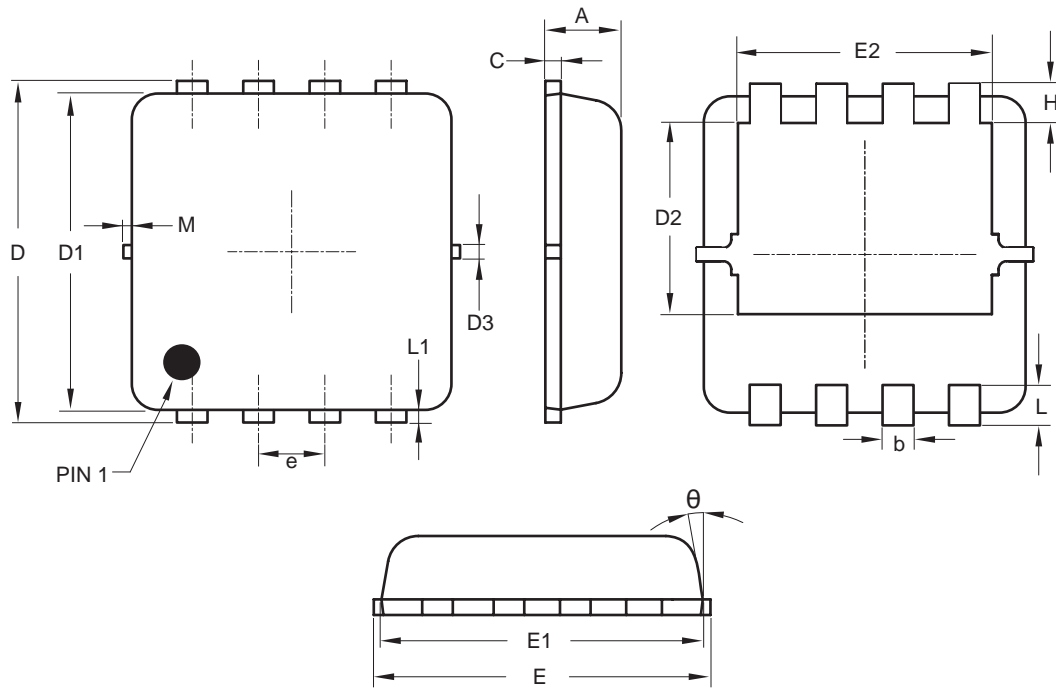

SYMBOLS	MILLIMETERS		
	MIN.	NOM.	MAX.
A	0.70	0.75	0.80
b	0.25	0.30	0.35
C	0.10	0.15	0.25
D	3.25	3.35	3.45
D1	3.00	3.10	3.20
D2	1.78	1.88	1.98
D3	—	0.13	—
E	3.20	3.30	3.40
E1	3.00	3.15	3.20
E2	2.39	2.49	2.59
e	0.65 BSC		
H	0.30	0.39	0.50
L	0.30	0.40	0.50
L1	—	0.13	—
M	—	—	0.15
θ	—	10°	12°

## TSON 3.3 x 3.3 Tape and Reel Data

### TSON 3.3 x 3.3 Tape

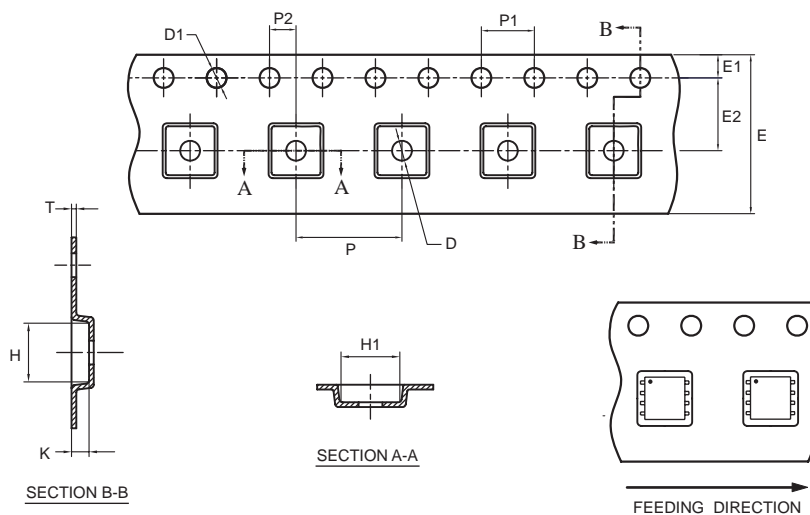

unit : mm

PACKAGE	D	D1	E	E1	E2	H	H1	K	P	P1	P2	T
TSON 3.3 x 3.3	$\phi 1.50$ (MIN)	$\phi 1.50$ +0.10 -0.00	12.0 +0.30 -0.10	1.75 $\pm 0.10$	5.50 $\pm 0.05$	3.70 $\pm 0.10$	3.70 $\pm 0.10$	1.10 $\pm 0.10$	8.0 $\pm 0.10$	4.0 $\pm 0.10$	2.0 $\pm 0.05$	0.3 $\pm 0.05$

### TSON 3.3 x 3.3 Reel

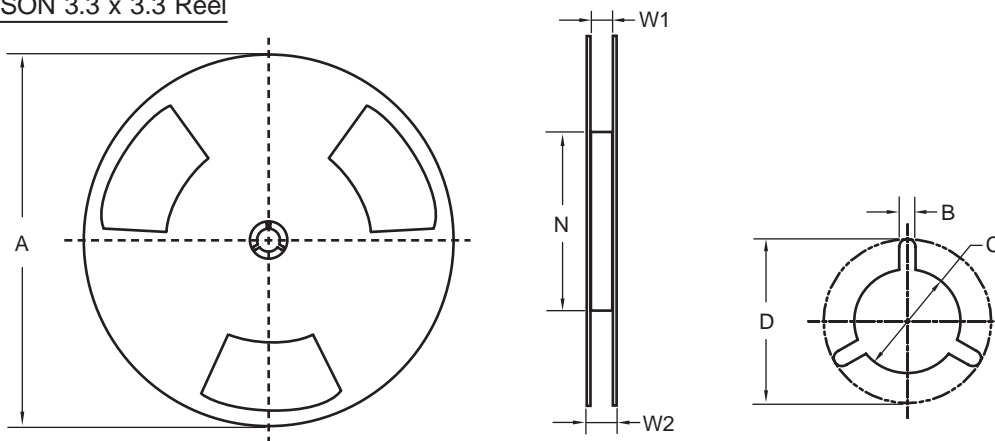

UNIT:mm

TAPE SIZE	REEL SIZE	A	B	C	D	N	W1	W2
12 mm	13 "	330 $\pm$ 1.0	1.5 $\begin{smallmatrix} +0.5 \\ -0.2 \end{smallmatrix}$	$\phi 13.0$ $\begin{smallmatrix} +0.5 \\ -0.2 \end{smallmatrix}$	20.2(ref.)	178 $\begin{smallmatrix} +0.0 \\ -2.0 \end{smallmatrix}$	12.4 $\begin{smallmatrix} +2.0 \\ -0.0 \end{smallmatrix}$	18.4(ref.)

## TOP MARKING DEFINITION

