



# NXP low-IF analog car radio tuners TEF662x

## Easy-to-use, cost-effective tuners for analog car radios

Building on the success of NXP's TEF660x and TEF661x families, the TEF662x uses a low-IF architecture to ensure high integration with low complexity. The result is easy design-in and best-in-class price/performance ratios.

### Key features

- ▶ Highly integrated tuners with low-IF conversion
- ▶ PLL synthesizer with integrated VCO
- ▶ Integrated AM LNA with AGC and RF selectivity (TEF6623 is FM-only)
- ▶ Integrated FM LNA with AGC
- ▶ Stereo decoder with output for interfacing with external analog or digital audio processor
- ▶ Advanced weak signal processing (soft mute, stereo blend, high cut control)
- ▶ PACS
- ▶ FM noise blanker
- ▶ Signal quality detection
- ▶ I<sup>2</sup>C-bus control
- ▶ RDS demodulator (TEF6623 & 24 only)
- ▶ Single 8.5 V supply
- ▶ SO32 package
- ▶ Very low external component count
- ▶ Allows for fast software development because of integrated radio knowledge and easy interface
- ▶ Very good strong signal behavior

### Key applications

- ▶ Aftermarket car radios
- ▶ Consumer radio

These tuners integrate all the critical RF components, so they're easy to design onto the main radio board. There's no need for a tuner module, and no alignments are required.

The performance, feature set, and quality of the TEF662x family are optimized to enable complementary pricing and product positioning for the cost-sensitive aftermarket car radio and consumer segments. All the devices in the family are software- and hardware- (pin-to-pin and application) compatible with each other as well with devices from the TEF660x and TEF661x families. This allows a single reference tuner design to address a range of requirements.

### Low-IF architecture

Many existing solutions require double IF (intermediate frequency) conversion. NXP's low-IF architecture eliminates the 10.7 MHz and 450 kHz IF transformer coils and ceramics,



as well as the expensive external components needed for LNA and AGC in the AM and FM front-ends. The TEF662x family also integrates a VCO, so there's no need for external LC tank components.

The low-IF architecture simplifies PCB layout, since there aren't any critical high-frequency lines and there's no need for alignments. Even designers with limited RF know-how

or resources can design the TEF662x onto the main PCB board, saving significant costs by making a tuner module design obsolete. Manufacturing is also easier, since full SMD applications, without hand mounting, are possible. Production throughput can be higher, too, because there are fewer small external components to handle, and there are no mechanical or software alignments to be made.

### Space savings delivered by TEF662x devices

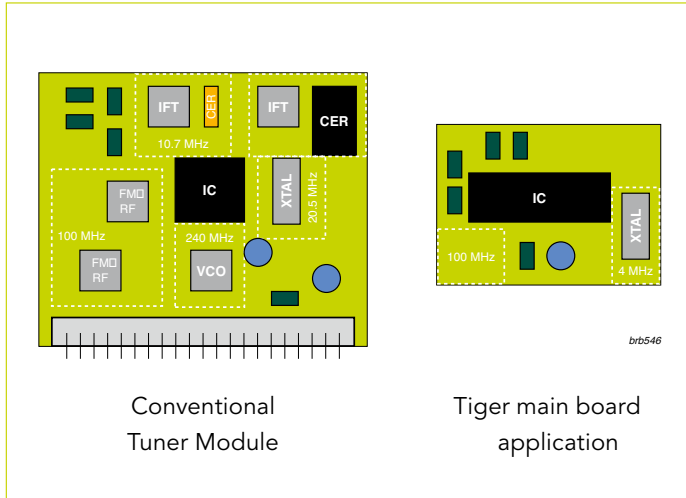

### TEF662x block and low-cost application diagram

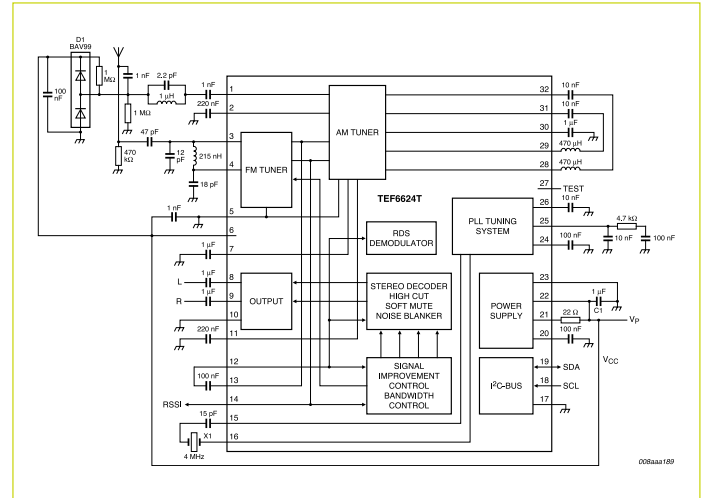

### TEF662x selection guide

| Type number |                       | TEF6621      | TEF6623       | TEF6624       |
|-------------|-----------------------|--------------|---------------|---------------|
| System      | Power supply          | 8.5 V        | 8.5 V         | 8.5 V         |
|             | Output                | L/R, MPX     | L/R, MPX, RDS | L/R, MPX, RDS |
|             | PACS                  | -            | •             | •             |
| R(B)DS      | Demodulator / decoder | -/-          | • / -         | • / -         |
| FM          | Japan / EU / US bands | •            | •             | •             |
|             | OIRT                  | -            | •             | •             |
|             | NB                    | •            | •             | •             |
|             | Stereo decoder        | •            | •             | •             |
|             | Weak signal handling  | •            | •             | •             |
| AM          | LW / MW               | •            | -             | •             |
|             | SW                    | -            | -             | -             |
|             | Weak signal handling  | •            | -             | •             |
| General     | Package               | SO32         | SO32          | SO32          |
|             | T <sub>amb</sub>      | -20 to 85 °C | -20 to 85 °C  | -20 to 85 °C  |
|             | Automotive            | No           | No            | No            |
|             | Product release       | Available    | Available     | Available     |