

- STRUCTURE Silicon Monolithic Integrated Circuit
- PRODUCT SERIES Strobe Charge Control IC
- TYPE **BD4216NUV**
- Functions
1. Built-in power transistor
 2. Adjustable transformer primary-side peak current
 3. Standby mode switching with the START pin
 4. Includes charge complete signal output (FULL) pin.
Includes charge voltage detection (VC) pin (can be set externally).
 5. Built-in thermal shutdown circuit (TSD)
 6. Built-in IGBT driver
 7. Thermally enhanced VSON010V3030 package. (3.0mm x 3.0mm, 1.0mm pitch)

○Absolute maximum ratings(Ta=25°C)

| Parameter | Symbol | Limit | Unit |
|---------------------------|---------|--------------------|------|
| VCC pin | VCC | -0.3 to 7 | V |
| PVC pin | PVC | 50 | V |
| VC pin | VC | -10 to 36 | V |
| START pin | START | -0.3 to 7 | V |
| ADJ pin | ADJ | -0.3 to 7 | V |
| FULL pin | FULL | -0.3 to 7 | V |
| IGBT_IN pin | IGBT_IN | -0.3 to 7 | V |
| Operating temperature | Topr | -35 to 85 | °C |
| Storage temperature range | Tstg | -55 to 150 | °C |
| Junction temperature | Tjmax | 150 | °C |
| Power dissipation | Pd | 1270 ^{*1} | mW |

*1: Reduced by 10.16 mW/°C over Ta = 25°C. (When mounted on 74.2 mm × 74.2 mm × 1.6 mm, glass epoxy)

○Recommended operating ranges

| Parameter | Symbol | Limit | Unit |
|--------------------------------------|----------|------------|------|
| VCC power supply input voltage range | VCC | 2.5 to 5.5 | V |
| START pin input voltage range | VSTART | 0 to VCC | V |
| ADJ pin input voltage range | VADJ | 0 to VCC | V |
| IGBT_IN pin input voltage range | VIGBT_IN | 0 to VCC | V |
| FULL pin input voltage range | VFULL | 0 to 5.5 | V |

©This product is not designed for normal operation within a radioactive environment.

Status of this document

The Japanese version of this document is the official specification. Please use the translation version of this document as a reference to expedite understanding of the official version.

If there are any uncertainty in translation version of this document, official version takes priority.

○Electrical characteristics (Ta=25°C, VCC=START=3.3 V, VBAT=3.6V, ADJ=1.0V)

| Parameter | Symbol | Limit | | | Unit | Conditions |
|--|------------------|-------|------|------|------|------------------------------|
| | | Min. | Typ. | Max. | | |
| [Overall device] | | | | | | |
| VCC circuit current | IVCC | — | 35 | 60 | mA | Output during ON time |
| Circuit current during standby operation | ISTB | — | — | 1 | uA | START=0V |
| [Standby control START pin] | | | | | | |
| START pin high voltage | VSTH | 2.0 | — | — | V | |
| START pin low voltage | VSTL | — | — | 0.4 | V | |
| Input bias current | ISTART | — | 24 | 40 | uA | START=3.3V |
| [Transformer primary-side driver block] | | | | | | |
| PVC pin leak current | IPVCL | — | — | 1 | uA | PVC=36V |
| PVC pin peak current 1 | IPEAK1 | 0.35 | 0.6 | 0.85 | A | ADJ=0V |
| PVC pin peak current 2 | IPEAK2 | 1.0 | 1.1 | 1.2 | A | ADJ=1V |
| PVC pin peak current 3 | IPEAK3 | 1.95 | 2.05 | 2.15 | A | ADJ=3V |
| PVC saturation voltage | VSAT | — | 0.3 | 1 | V | ISW=0.5A |
| [Charging control block] | | | | | | |
| ADJ sink current | IADJ | — | 2.5 | 10 | uA | |
| Off time | TOFFMAX | — | 10 | 30 | uS | |
| [Transformer secondary-side detection block] | | | | | | |
| Full charge detection voltage | VFULLTH | 29.7 | 30 | 30.3 | V | |
| FULL pin ON resistor | RFULLL | — | 110 | 300 | Ω | FULL=0.5V |
| FULL pin leak current | IFULLH | — | — | 1 | uA | FULL=3.3V |
| [Protection circuit block] | | | | | | |
| UVLO detect voltage | VUVLOTH | — | — | 2.25 | V | VCC detection |
| [IGBT driver block] | | | | | | |
| Output short high current | I _{oso} | 70 | 140 | — | mA | IGBT_IN=3.3V, IGBT_OUT=0V |
| Output short low current | I _{osi} | 30 | 60 | — | mA | IGBT_IN=0V, IGBT_OUT=3.3V |
| IGBT_IN input high voltage range | VIGBTH | 2.0 | — | — | V | |
| IGBT_IN input low voltage range | VIGBTL | — | — | 0.4 | V | |
| IGBT_IN sink current | IIGBT_IN | — | 24 | 40 | uA | IGBT_IN=3.3V |

○Package (UNIT:mm)

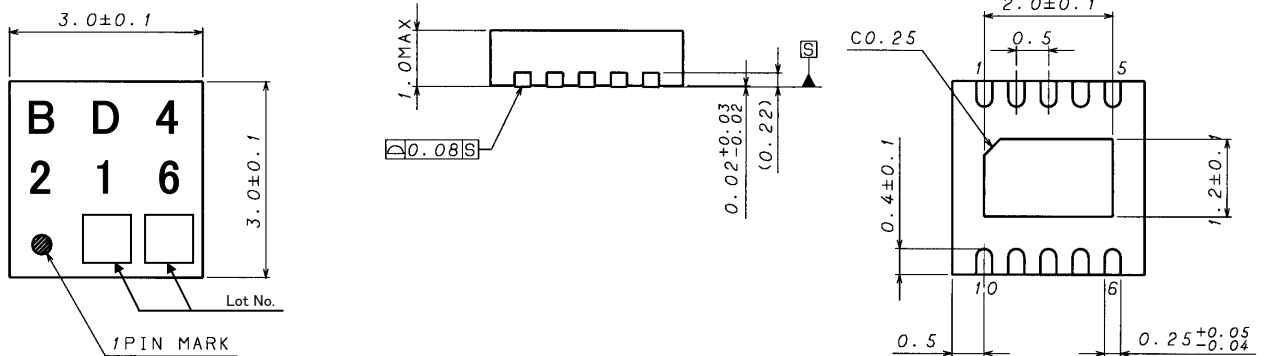

○Pin Layout

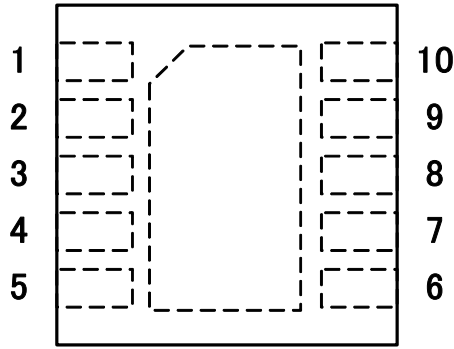

TOP VIEW
Fig.1 Pin Layout

| Pin No. | Pin Name | Function |
|---------|----------|----------------------------------|
| 1 | PGND | Ground pin |
| 2 | IGBT_OUT | IGBT driver output pin |
| 3 | IGBT_IN | IGBT driver input pin |
| 4 | FULL | FULL charge detection flag pin |
| 5 | ADJ | primary-side current control pin |
| 6 | START | Standby pin |
| 7 | VCC | VCC pin |
| 8 | VC | Full charge detection pin |
| 9 | N/C | N/C |
| 10 | PVC | Power transistor output pin |

Block Diagram

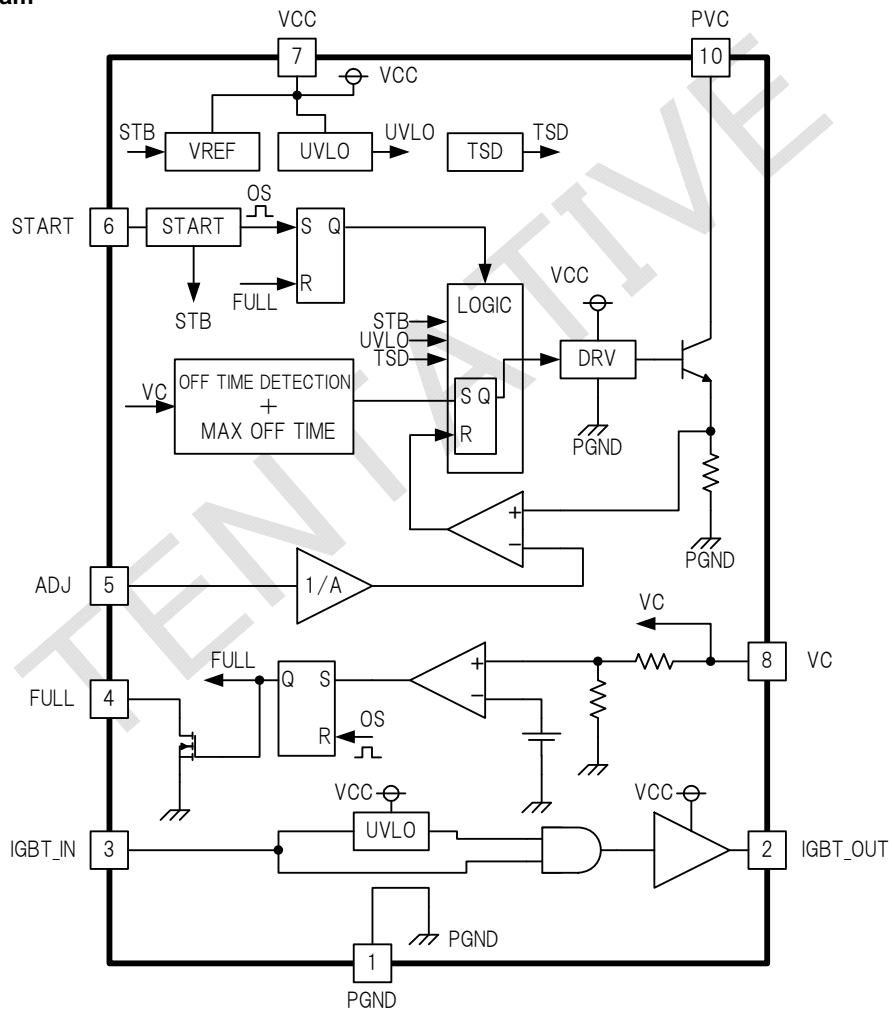

Fig.2 Block Diagram

○ Cautions on use

1. Absolute maximum ratings
An excess in the absolute maximum ratings, such as supply voltage, temperature range of operating conditions, etc., can break down the devices, thus making impossible to identify breaking mode, such as a short circuit or an open circuit. If any over rated values will expect to exceed the absolute maximum ratings, consider adding circuit protection devices, such as fuses.
2. PGND potential
Ensure a minimum GND pin potential in all operating conditions. In addition, ensure that no pins other than the GND pin carry a voltage less than or equal to the GND pin, including during actual transient phenomena.
3. Thermal design
Use a thermal design that allows for a sufficient margin in light of the power dissipation (Pd) in actual operating conditions.
4. Protect circuit
The IC does not incorporate built-in malfunction protection such as overcurrent protection, short detection, or thermal shutdown circuitry. For this reason, the IC may be damaged if it is shorted or subjected to a load that exceeds the package power. The design of peripheral application circuits should reflect these potential risks.
5. Inter-pin shorts and mounting errors
Use caution when positioning the IC for mounting on printed circuit boards. The IC may be damaged if there is any connection error or if positive and ground power supply terminals are reversed. The IC may also be damaged if pins are shorted together or are shorted to other circuit's power lines.
6. Common impedance
The power supply and ground lines must be as short and thick as possible to reduce line impedance. Fluctuating voltage on the power ground line may damage the device.
7. Backside copper foil
Connect to PGND pin for protection of malfunction.
8. Thermal shutdown
there is a temperature protection circuit in the body ,for protect from heating damage, When thermal circuit moved, output is OFF condition. However it would be fixed automatically, If it return to regular temperature.
9. Voltage of START pin
The threshold voltages of START pin are 2.0V. STB state is set below 0.4V while action state is set beyond 2.0V.The region between 0.4V and 2.0V is not recommended and may cause improper operation.

Notes

No copying or reproduction of this document, in part or in whole, is permitted without the consent of ROHM Co.,Ltd.

The content specified herein is subject to change for improvement without notice.

The content specified herein is for the purpose of introducing ROHM's products (hereinafter "Products"). If you wish to use any such Product, please be sure to refer to the specifications, which can be obtained from ROHM upon request.

Examples of application circuits, circuit constants and any other information contained herein illustrate the standard usage and operations of the Products. The peripheral conditions must be taken into account when designing circuits for mass production.

Great care was taken in ensuring the accuracy of the information specified in this document. However, should you incur any damage arising from any inaccuracy or misprint of such information, ROHM shall bear no responsibility for such damage.

The technical information specified herein is intended only to show the typical functions of and examples of application circuits for the Products. ROHM does not grant you, explicitly or implicitly, any license to use or exercise intellectual property or other rights held by ROHM and other parties. ROHM shall bear no responsibility whatsoever for any dispute arising from the use of such technical information.

The Products specified in this document are intended to be used with general-use electronic equipment or devices (such as audio visual equipment, office-automation equipment, communication devices, electronic appliances and amusement devices).

The Products specified in this document are not designed to be radiation tolerant.

While ROHM always makes efforts to enhance the quality and reliability of its Products, a Product may fail or malfunction for a variety of reasons.

Please be sure to implement in your equipment using the Products safety measures to guard against the possibility of physical injury, fire or any other damage caused in the event of the failure of any Product, such as derating, redundancy, fire control and fail-safe designs. ROHM shall bear no responsibility whatsoever for your use of any Product outside of the prescribed scope or not in accordance with the instruction manual.

The Products are not designed or manufactured to be used with any equipment, device or system which requires an extremely high level of reliability the failure or malfunction of which may result in a direct threat to human life or create a risk of human injury (such as a medical instrument, transportation equipment, aerospace machinery, nuclear-reactor controller, fuel-controller or other safety device). ROHM shall bear no responsibility in any way for use of any of the Products for the above special purposes. If a Product is intended to be used for any such special purpose, please contact a ROHM sales representative before purchasing.

If you intend to export or ship overseas any Product or technology specified herein that may be controlled under the Foreign Exchange and the Foreign Trade Law, you will be required to obtain a license or permit under the Law.



Thank you for your accessing to ROHM product informations.
More detail product informations and catalogs are available, please contact us.

ROHM Customer Support System

<http://www.rohm.com/contact/>