

DUAL OPERATIONAL AMPLIFIER-DUAL COMPARATOR ADJUSTABLE VOLTAGE REFERENCE

The KIA7102AP/AF is a monolithic IC that includes two OP-Amps, two Comparators and a precision voltage reference. This device is offering space and cost saving in many applications like power supply management or data acquisition systems.

FEATURES

- Low Supply Current : $I_{CC}=0.8\text{mA}$ (Typ.)
- Low Input Offset Voltage : $V_{IO}=2\text{mV}$ (Typ.)
- Wide Common Mode Input Voltage : $V_{CC}-1.5\text{V}$ (Typ.)
- Low Input Bias Current
 - : $I_i=45\text{nA}$ /Typ. (OP-Amps Part)
 - : $I_i=25\text{nA}$ /Typ. (Comparators Part)
- Wide Supply Voltage (Single Supply/Dual Supply)
 - : $V_{CC}=3\sim 36\text{V}$ ($\pm 1.5\sim \pm 18\text{V}$) (OP-Amps Part)
 - : $V_{CC}=2\sim 36\text{V}$ ($\pm 1\sim \pm 18\text{V}$) (Comparators Part)
- Programmable Output Voltage : $V_{ref}\sim 36\text{V}$
- Voltage Reference Tolerance : $V_{ref}\pm 0.4\%$
- Sink Current Capability : $I_K=1\sim 100\text{mA}$
- Equivalent Full Range Temperature Coefficient
 - : $\Delta V_{ref}=7\text{mV}$ (T_{opr} Range)

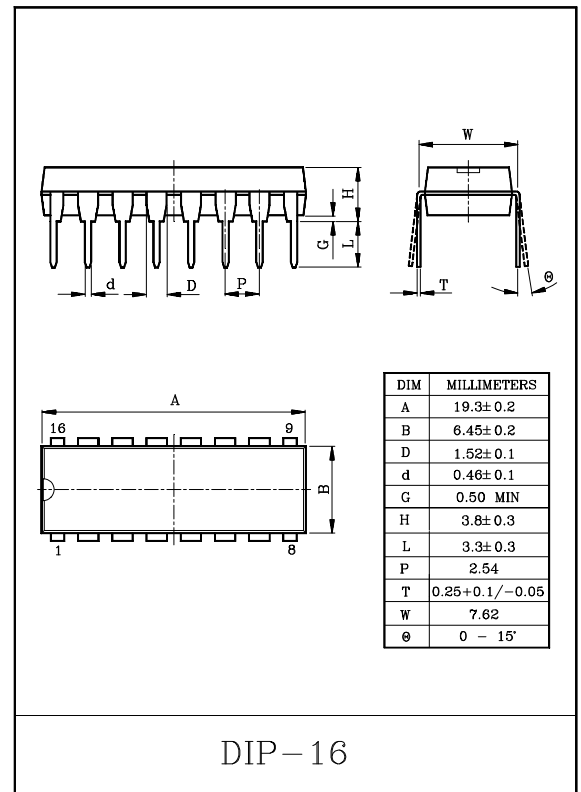

PIN CONNECTION (TOP VIEW)

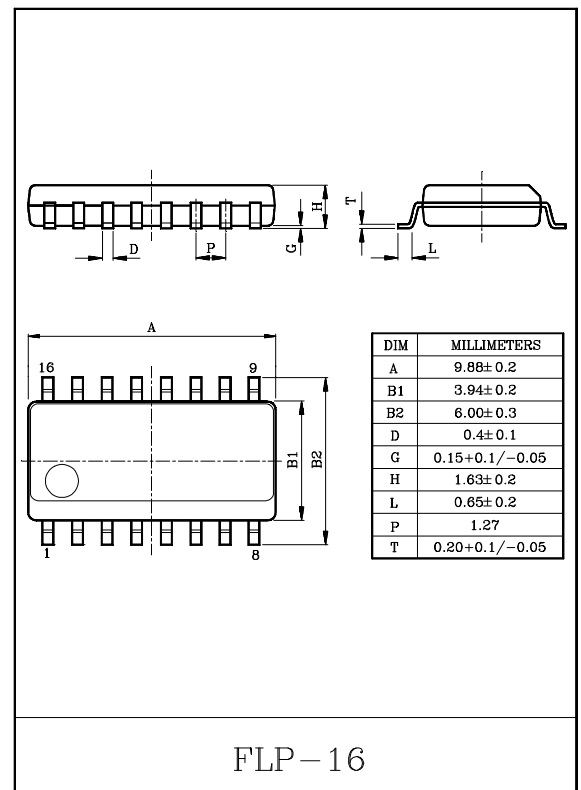
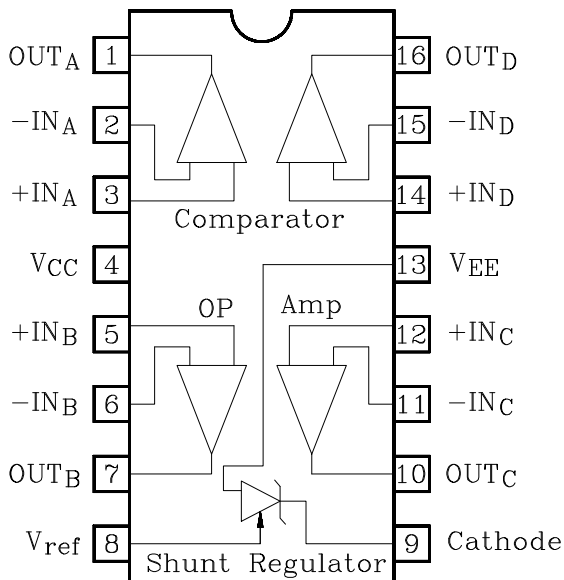

KIA7102AP/AF

MAXIMUM RATINGS (Ta=25°C)

CHARACTERISTIC	SYMBOL	RATING	UNIT	
OP-AMP & COMPARATOR PART				
Supply Voltage	V _{CC}	0 ~ ±18 (0 ~ 36)	V	
Differential Input Voltage	DV _{IN}	0 ~ ±18 (0 ~ 36)	V	
Common Mode Input Voltage	CMV _{IN}	-0.3 ~ 36	V	
SHUNT REGULATOR PART				
Cathode to Anode Voltage	V _{KA}	37	V	
Cathode Current Range, Continuous	I _K	-100 ~ 150	mA	
Reference Input Current Range, Continuous	I _{REF}	-0.05 ~ 10	mA	
TOTAL				
Power Dissipation	P	P _D	1.47	W
	F		0.54	
Operating Temperature	T _{opr}	-40 ~ 85	°C	
Storage Temperature	T _{stg}	-55 ~ 125	°C	

ELECTRICAL CHARACTERISTICS

OPERATIONAL AMPLIFIERS PART

(Unless otherwise specified : V_{CC}=5V, V_{EE}=GND)

CHARACTERISTIC	SYMBOL	TEST CONDITION	MIN.	TYP.	MAX.	UNIT
Input Offset Voltage	V _{IO}	R _g ≤ 10kΩ	-	2	7	mV
Input Offset Voltage Drift	V _{IO} /ΔT	R _g ≤ 10kΩ	-	10	-	μV/°C
Input Bias Current	I _I	-	-	45	150	nA
Input Offset Current	I _{IO}	-	-	5	30	nA
Voltage Gain	G _v	R _L ≥ 2kΩ	86	100	-	dB
Supply Voltage Rejection Ratio	SVRR	R _g =10kΩ	60	100	-	dB
Common Mode Input Voltage	CMV _{IN}	V _{CC} =30V, V _{EE} =GND	0	-	V _{CC} -1.5	V
Common Mode Input Signal Rejection Ratio	CMRR	-	60	85	-	dB
Source Current	I _{SOURCE}	-IN=0V, +IN=1V	20	40	-	mA
Sink Current	I _{SINK}	-IN=1V, +IN=0V	10	20	-	mA
High Level Output Voltage	V _{OH}	R _L =10kΩ, V _{CC} =30V	27	28	-	V
Low Level Output Voltage	V _{OL}	R _L =10kΩ, V _{CC} =30V	-	0.1	0.15	V
Slew Rate	S/R	R _L =2kΩ	-	0.5	-	V/μs
Unity Gain Frequency	f _T	G _v =1	-	0.7	-	MHz
Total Harmonic Distortion	THD	-	-	0.05	-	%
Phase Margin	φ _m	G _v =1	-	45	-	Degress
Equivalent Input Noise Voltage	V _{NI}	R _s =1kΩ, BW=Din Audio	-	2.5	-	μVrms
Channel Separation	CH _{SEP}	-	-	120	-	1dB

KIA7102AP/AF

COMPARATORS PART

(Unless otherwise specified : $V_{CC}=5V$, $V_{EE}=GND$)

CHARACTERISTIC	SYMBOL	TEST CONDITION	MIN.	TYP.	MAX.	UNIT
Input Offset Voltage	V_{IO}	-	-	2	5	mV
Input Bias Current	I_I	-	-	25	250	nA
Input Offset Current	I_{IO}	-	-	5	50	nA
Output Leak Current	I_{LEAK}	+IN=1V, -IN=0, $V_{CC}=V_O=30V$	-	0.1	-	nA
Low Level Output Voltage	V_{OL}	+IN=0, -IN=1V, $I_{SINK}=4mA$	-	0.2	0.4	V
Voltage Gain	G_V	$R_L=15k\Omega$	-	200	-	V/mV
Output Sink Current	I_{SINK}	+IN=0, -IN=1V, $V_{OL}=1.5V$	6	16	-	mA
Common Mode Input Voltage	CMV_{IN}	-	0	-	$V_{CC}-1.5$	V
Differential Input Voltage	DV_{IN}	-	-	-	36	V
Response Time	t_{RSP1}	$R_L=5.1k\Omega$, $C_L=15pF$	-	1.3	-	μs
Large Signal Response Time	t_{RSP2}	$V_{ref}=1.4V$, $R_L=5.1k\Omega$, $C_L=15pF$	-	300	-	ns

VOLTAGE REFERENCE PART

CHARACTERISTIC	SYMBOL	TEST CONDITION	MIN.	TYP.	MAX.	UNIT
Reference Input Voltage	V_{ref1}	$V_{KA}=V_{ref}$, $I_K=10mA$	2.490	2.500	2.510	V
Reference Input Voltage Deviation Over Temperature Range	ΔV_{ref}	$V_{KA}=V_{ref}$, $I_K=10mA$	-	7	30	mV
Temperature Coefficient of Reference Input Voltage	$\frac{\Delta V_{ref}}{\Delta T}$	$V_{KA}=V_{ref}$, $I_K=10mA$	-	± 22	± 100	ppm/ $^{\circ}C$
Ratio of Change in Reference Input Voltage to Change in Cathode to Anode Voltage	$\frac{\Delta V_{ref}}{\Delta V_{KA}}$	$I_K=10mA$, $\Delta V_{KA}=36\sim 3V$	-	-1.1	-2	mV/V
Reference Input Current	I_{ref}	$V_{KA}=V_{ref}$, $R_1=10k\Omega$	-	1.5	4.0	μA
Reference Input Current Deviation Over Temperature Range	ΔI_{ref}	$V_{KA}=V_{ref}$, $R_1=10k\Omega$	-	0.8	2.5	μA
Minimum Cathode Current For Regulation	I_{min}	$V_{KA}=V_{ref}$	-	0.5	1	mA
Off Start Cathode Current	I_{off}	$V_{KA}=36V$, $V_{ref}=0$	-	2.6	500	nA

TOTAL

(Unless otherwise specified : $V_{CC}=5V$, $V_{EE}=GND$)

CHARACTERISTIC	SYMBOL	TEST CONDITION	MIN.	TYP.	MAX.	UNIT
Supply Current	I_{CC}	-	-	0.8	1.5	mA