

52-Port L2/L3 Enterprise Gigabit Ethernet Switch with 10 Gbps Links

Vitesse's next generation switch family delivers a flexible Enterprise and Industrial Ethernet solution.

The VSC7448 SparX-IV-80™ device is an 80 Gbps SMB/SME Industrial Ethernet switch with up to 52 ports supporting a combination of 1G, 2.5G, and 10G Ethernet ports.

The device provides a rich set of Enterprise Ethernet switching features. Using multistage Vitesse TCAM technology (VCAP™), it delivers VLAN and QoS processing that enables delivery of differentiated services, security through intelligent frame processing, and egress frame manipulation.

For industrial applications, VSC7448 integrates VeriTime™, Vitesse's patent-pending distributed timing technology that delivers the industry's most accurate IEEE 1588v2 timing implementation.

A powerful 500 MHz CPU enables full management of a Layer 2 and Layer 3 Ethernet switch solution.

A comprehensive application programming interface (API) and software development package accelerates time-to-market for managed Ethernet applications. The software API package integrates easily with third-party software, preserving existing software investments.

Highlights

- Up to 48 × 1G, 24 × 2.5G, and 4 × 10G Ethernet ports
- Fully managed L2 switching and L3 forwarding features
- Industrial temperature range
- Easy upgrade within SparX-IV family to higher bandwidth including 10 GbE port support

Applications

- Fully managed L2/L3 switch
- Industrial Ethernet switch

24 × 1 GbE + 4 × 10 GbE Managed Switch
(Optical 1 GbE Ports)

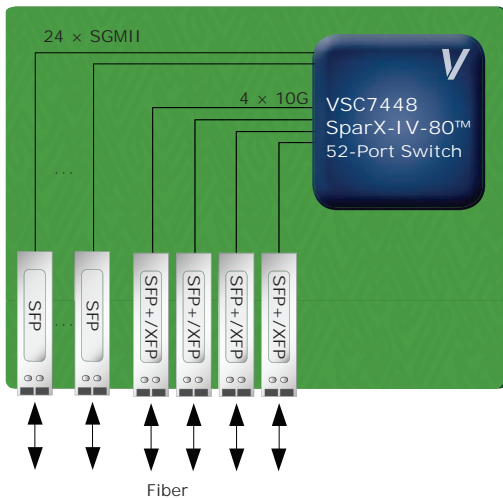

40 × 1 GbE + 4 × 10 GbE Managed Switch
(Copper 1 GbE Ports)

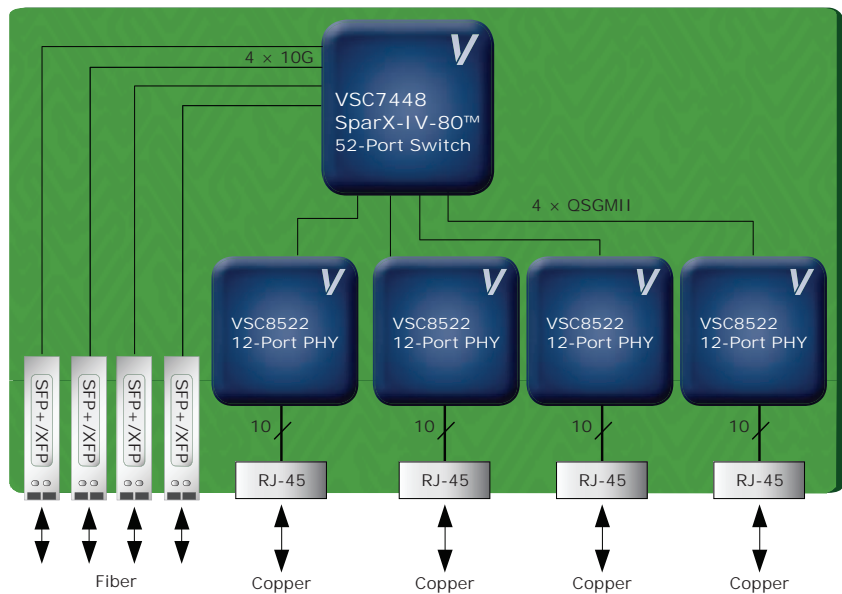

Features

- Main port configurations:
36 × 1G SGMII
12 × QSGMII
4 × 10G (SFI/XAUI/RXAUI)
24 × 2.5G SGMII
- Additional 10/100/1000 Mbps SGMII/SerDes node processor
- Integrated 500 MHz MIPS 24KEc CPU with MMU and DDR3/DDR3L SDRAM controller
- PCIe 1.x CPU interface
- Internal shared memory buffer (8 queues per port)
- Jumbo frame support
- Strict priority and DWRR scheduler/shaper

Layer 2 Switching and Layer 3 Forwarding

- 802.1Q VLAN switch with 32K MACs and 4K VLANs
- Push/pop/translate up to three VLAN tags on ingress and egress
- Policing with storm control and MC/BC protection
- RSTP and MSTP support
- Independent and shared VLAN learning (IVL, SVL)
- Hardware- and software-based learning
- TCAM-based classification and VCAP-II security
- Layer 3 unicast and multicast routing

Multicast

- Layer 2
- IPv4 and IPv6
- IGMP and MLD

Industrial Ethernet

- Integrated timing: VeriTime™ (1588v2) and SyncE support
- Ethernet ring protection switching (ERPS)

Key Specifications

- 27 mm × 27 mm FCBGA
- -40 °C to 110 °C operating temperature

Related Vitesse Products

Visit www.vitesse.com for information about these related Vitesse products:

- SparX-III nonstackable GbE switches with integrated copper PHYs
- VSC8512 and VSC8522 12-port copper PHYs
- Unified API, WebStaX™, and SMBStaX™ software

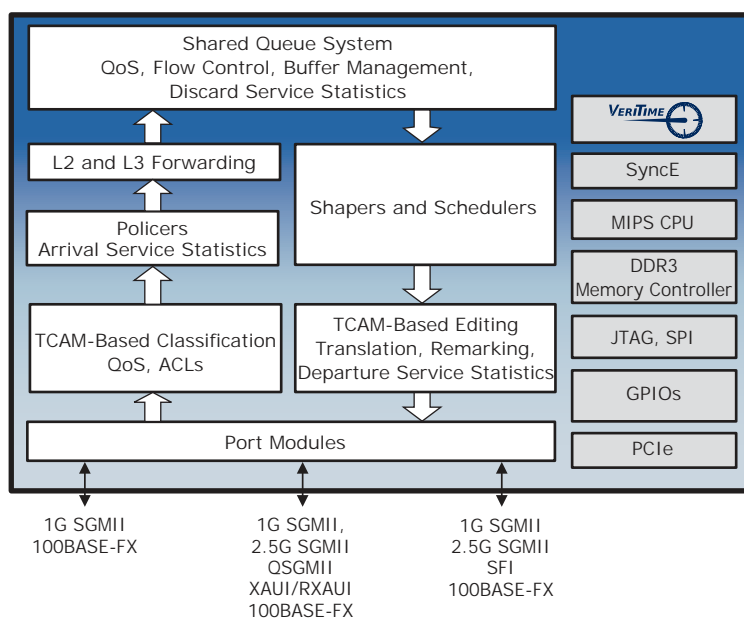

Vitesse Semiconductor Corporation

www.vitesse.com