

HIGH SPEED SWITCHES

DESCRIPTION

The 2N2218A, 2N2219A, 2N2221A and 2N2222A are silicon planar epitaxial NPN transistors in Jedec TO-39 (for 2N2218A and 2N2219A) and in Jedec TO-18 (for 2N2221A and 2N2222A) metal cases. They are designed for high-speed switching applications at collector currents up to 500 mA, and feature useful current gain over a wide range of collector current, low leakage currents and low saturation voltages.

 2N2218A/2N2219A approved to CECC 50002-100, 2N2221A/2N2222A approved to CECC 50002-101 available on request.

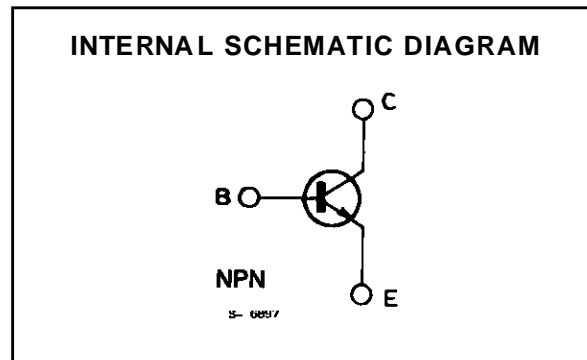
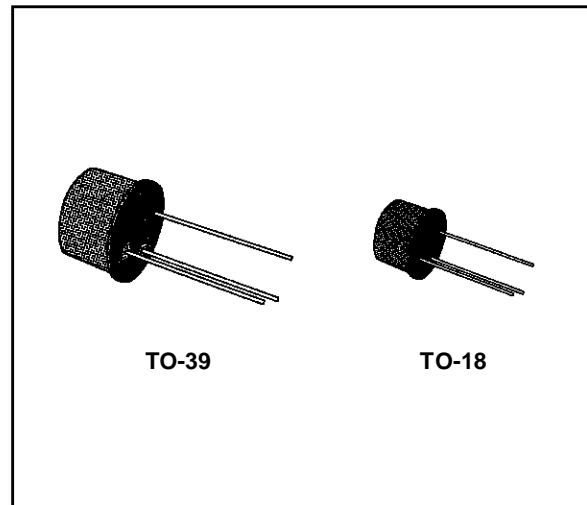

ABSOLUTE MAXIMUM RATINGS

Symbol	Parameter	Value	Unit
V_{CBO}	Collector-base Voltage ($I_E = 0$)	75	V
V_{CEO}	Collector-emitter Voltage ($I_B = 0$)	40	V
V_{EBO}	Emitter-base Voltage ($I_C = 0$)	6	V
I_C	Collector Current	0.8	A
P_{tot}	Total Power Dissipation at $T_{amb} \leq 25^\circ C$ for 2N2218 A and 2N2219A for 2N2221 A and 2N2222A at $T_{case} \leq 25^\circ C$ for 2N2218 A and 2N2219A for 2N2221 A and 2N2222A	0.8	W
		0.5	W
		3	W
		1.8	W
T_{stg}	Storage Temperature	- 65 to 200	$^\circ C$
T_j	Junction Temperature	175	$^\circ C$

2N2218A-2N2219A-2N2221A-2N2222A

THERMAL DATA

			2N2218A 2N2219A	2N2221A 2N2222A
$R_{th\ j-case}$	Thermal Resistance Junction-case	Max	50 °C/W	83.3 °C/W
$R_{th\ j-amb}$	Thermal Resistance Junction-ambient	Max	187.5 °C/W	300 °C/W

ELECTRICAL CHARACTERISTICS ($T_{amb} = 25\text{ °C}$ unless otherwise specified)

Symbol	Parameter	Test Conditions	Min.	Typ.	Max.	Unit
I_{CBO}	Collector Cutoff Current ($I_E = 0$)	$V_{CB} = 60\text{ V}$			10	nA
		$V_{CB} = 6.0\text{ V}$ $T_{amb} = 150\text{ °C}$			10	μA
I_{CEX}	Collector Cutoff Current ($V_{BE} = -3\text{ V}$)	$V_{CE} = 6.0\text{ V}$			10	nA
I_{EBO}	Emitter Cutoff Current ($I_C = 0$)	$V_{EB} = 3\text{ V}$			10	nA
I_{BEX}	Base Cutoff Current ($V_{BE} = -3\text{ V}$)	$V_{CE} = 6.0\text{ V}$			20	nA
$V_{(BR)\ CBO}$	Collector-base Breakdown Voltage ($I_E = 0$)	$I_C = 1.0\ \mu\text{A}$	5			V
$V_{(BR)\ CEO}^*$	Collector-emitter Breakdown Voltage ($I_B = 0$)	$I_C = 1.0\text{ mA}$	40			V
$V_{(BR)\ EBO}$	Emitter-base Breakdown Voltage ($I_C = 0$)	$I_E = 1.0\ \mu\text{A}$				V
$V_{CE(sat)}^*$	Collector-emitter Saturation Voltage	$I_C = 1.50\text{ mA}$ $I_B = 1.5\text{ mA}$			0.3	V
		$I_C = 5.00\text{ mA}$ $I_B = 5.0\text{ mA}$			1	V
$V_{BE(sat)}^*$	Base-emitter Saturation Voltage	$I_C = 1.50\text{ mA}$ $I_B = 1.5\text{ mA}$	0.6		1.2	V
		$I_C = 5.00\text{ mA}$ $I_B = 5.0\text{ mA}$			2	V
h_{FE}^*	DC Current Gain	for 2N2218A and 2N2221A				
		$I_C = 0.1\text{ mA}$ $V_{CE} = 1.0\text{ V}$	20			
		$I_C = 1\text{ mA}$ $V_{CE} = 1.0\text{ V}$	25			
		$I_C = 1.0\text{ mA}$ $V_{CE} = 1.0\text{ V}$	35			
		$I_C = 1.50\text{ mA}$ $V_{CE} = 1.0\text{ V}$	40		120	
		$I_C = 5.00\text{ mA}$ $V_{CE} = 1.0\text{ V}$	25			
		$I_C = 1.50\text{ mA}$ $V_{CE} = 1\text{ V}$	20			
		$I_C = 1.0\text{ mA}$ $V_{CE} = 1.0\text{ V}$	15			
h_{FE}^*	DC Current Gain	for 2N2219A and 2N2222A				
		$I_C = 0.1\text{ mA}$ $V_{CE} = 1.0\text{ V}$	35			
		$I_C = 1\text{ mA}$ $V_{CE} = 1.0\text{ V}$	50			
		$I_C = 1.0\text{ mA}$ $V_{CE} = 1.0\text{ V}$	75			
		$I_C = 1.50\text{ mA}$ $V_{CE} = 1.0\text{ V}$	100		300	
		$I_C = 5.00\text{ mA}$ $V_{CE} = 1.0\text{ V}$	40			
		$I_C = 1.50\text{ mA}$ $V_{CE} = 1\text{ V}$	50			
		$I_C = 1.0\text{ mA}$ $V_{CE} = 1.0\text{ V}$	35			
	$T_{amb} = -55\text{ °C}$					

* Pulsed : pulse duration = 300 μs , duty cycle = 1 %.

ELECTRICAL CHARACTERISTICS (continued)

Symbol	Parameter	Test Conditions	Min.	Typ.	Max.	Unit
h_{fe}	Small Signal Current Gain	$I_C = 1 \text{ mA}$ $V_{CE} = 10 \text{ V}$ $f = 1 \text{ kHz}$ for 2N2218A and 2N2221A for 2N2219A and 2N2222A $I_C = 10 \text{ mA}$ $V_{CE} = 10 \text{ V}$ $f = 1 \text{ kHz}$ for 2N2218A and 2N2221A for 2N2219A and 2N2222A	30 50 50 75		150 300 300 375	
f_T	Transition Frequency	$I_C = 20 \text{ mA}$ $V_{CE} = 2.0 \text{ V}$ $f = 100 \text{ MHz}$ for 2N2218A and 2N2221A for 2N2219A and 2N2222A	250 300			MHz MHz
C_{EBO}	Emitter-base Capacitance	$I_C = 0$ $f = 100 \text{ kHz}$ $V_{EB} = 0.5 \text{ V}$			25	pF
C_{CBO}	Collector-base Capacitance	$I_E = 0$ $f = 100 \text{ kHz}$ $V_{CB} = 1.0 \text{ V}$			8	pF
$R_{e(hie)}$	Real Part of Input Impedance	$I_C = 2.0 \text{ mA}$ $f = 300 \text{ MHz}$ $V_{CE} = 2.0 \text{ V}$			60	Ω
NF	Noise Figure	$I_C = 1.00 \mu\text{A}$ $V_{CE} = 1.0 \text{ V}$ $R_g = 1 \text{ k}\Omega$ $f = 1 \text{ kHz}$		4d		B
h_{ie}^{**}	Input Impedance	$I_C = 1 \text{ mA}$ $V_{CE} = 1.0 \text{ V}$ for 2N2218A and 2N2221A for 2N2219A and 2N2222A $I_C = 1.0 \text{ mA}$ $V_{CE} = 1.0 \text{ V}$ for 2N2218A and 2N2221A for 2N2219A and 2N2222A	1 2 0.2 0.25		3.5 8 1 1.25	Ω Ω Ω Ω
h_{re}^{**}	Reverse Voltage Ratio	$I_C = 1 \text{ mA}$ $V_{CE} = 1.0 \text{ V}$ for 2N2218A and 2N2221A for 2N2219A and 2N2222A $I_C = 1.0 \text{ mA}$ $V_{CE} = 1.0 \text{ V}$ for 2N2218A and 2N2221A for 2N2219A and 2N2222A			5×10^{-4} 8×10^{-4} 2.5×10^{-4} 4×10^{-4}	
h_{oe}^{**}	Output Admittance	$I_C = 1 \text{ mA}$ $V_{CE} = 1.0 \text{ V}$ for 2N2218A and 2N2221A for 2N2219A and 2N2222A $I_C = 1.0 \text{ mA}$ $V_{CE} = 1.0 \text{ V}$ for 2N2218A and 2N2221A for 2N2219A and 2N2222A	3 5 10 25		15 35 100 200	μS μS μS μS
t_d^{***}	Delay Time	$I_C = 1.50 \text{ mA}$ $V_{CC} = 3.0 \text{ V}$ $I_{B1} = 1.5 \text{ mA}$ $V_{BB} = -0.5 \text{ V}$			10	ns
t_r^{***}	Rise Time	$I_C = 1.50 \text{ mA}$ $V_{CC} = 3.0 \text{ V}$ $I_{B1} = 1.5 \text{ mA}$ $V_{BB} = -0.5 \text{ V}$			25	ns
t_s^{***}	Storage Time	$I_C = 1.50 \text{ mA}$ $V_{CC} = 3.0 \text{ V}$ $I_{B1} = -I_{B2} = 1.5 \text{ mA}$			225	ns
t_f^{***}	Fall Time	$I_C = 1.50 \text{ mA}$ $V_{CC} = 3.0 \text{ V}$ $I_{B1} = -I_{B2} = 1.5 \text{ mA}$			60	ns
$r_{bb} \cdot C_{b'c}$	Feedback Time Constant	$I_C = 2.0 \text{ mA}$ $f = 31.8 \text{ MHz}$ $V_{CE} = 20 \text{ V}$			150	ps

** $f = 1 \text{ kHz}$

*** see test circuit.

2N2218A-2N2219A-2N2221A-2N2222A

Normalized DC Current Gain.

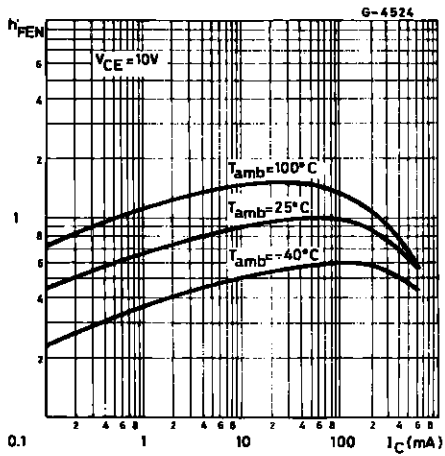

Collector-emitter Saturation Voltage.

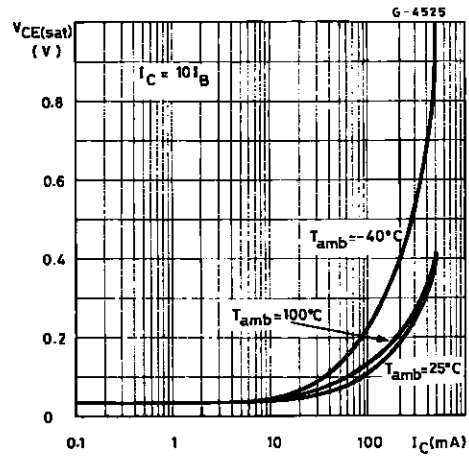

Contours of Constant Narrow Band Noise Figure.

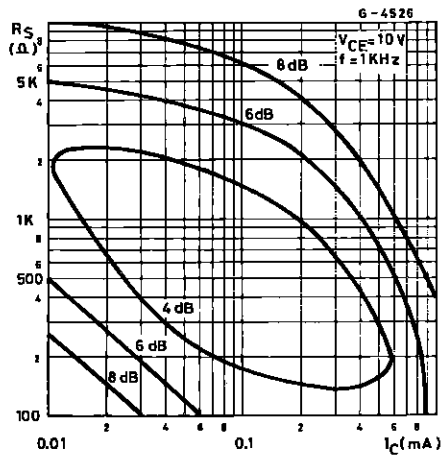

Switching Time vs. Collector Current.

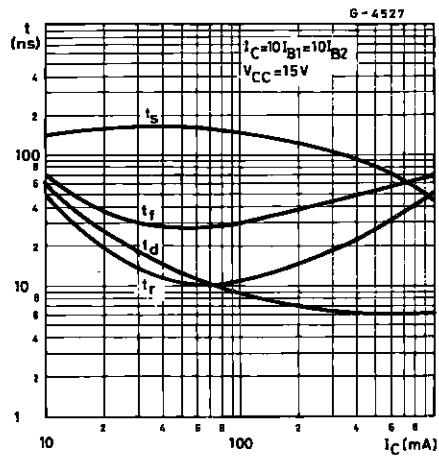

Test Circuit for t_d , t_r .

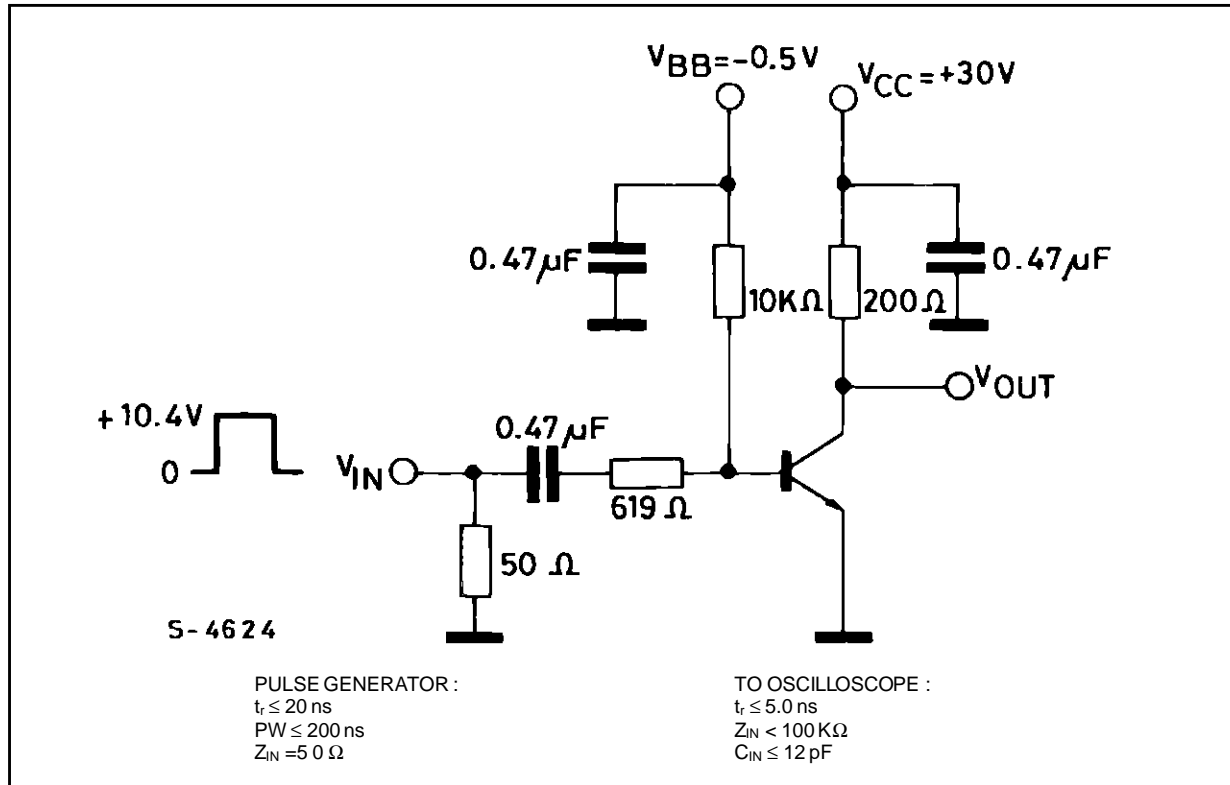

Test Circuit for t_d , t_r .

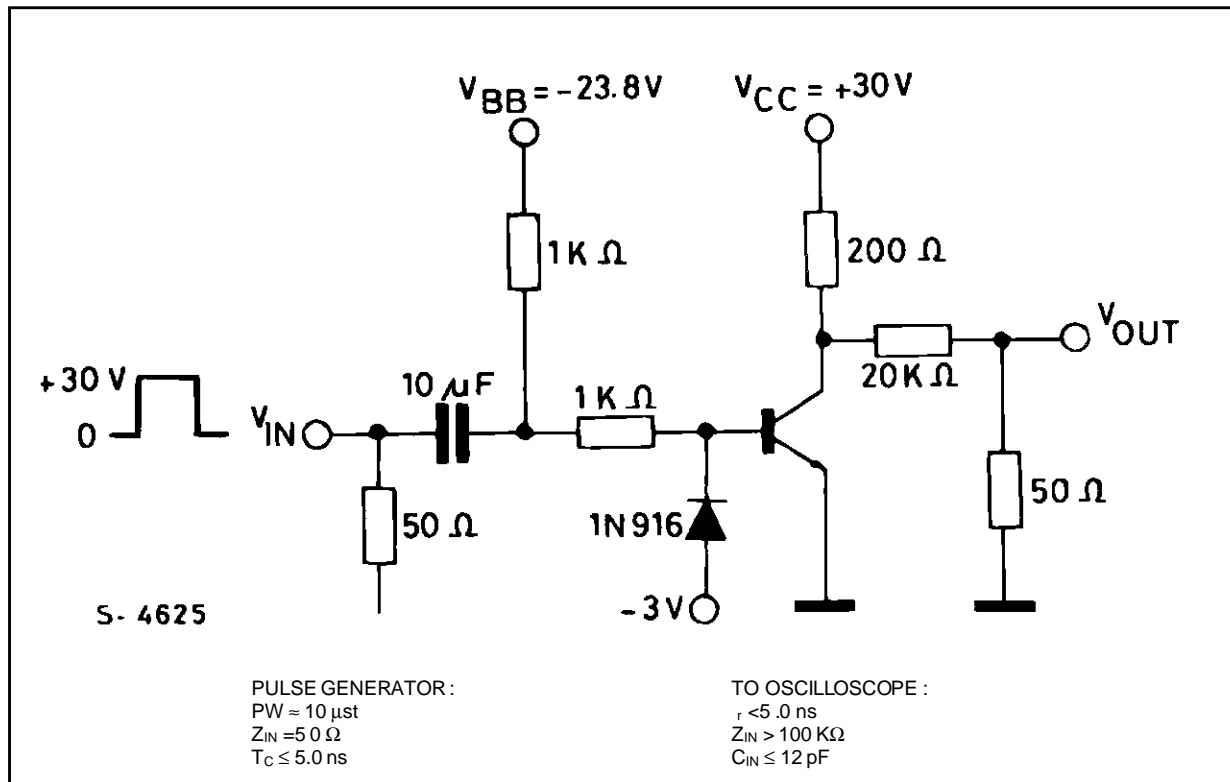

TO-18 MECHANICAL DATA

DIM.	mm			inch		
	MIN.	TYP.	MAX.	MIN.	TYP.	MAX.
A		12.7			0.500	
B			0.49			0.019
D			5.3			0.208
E			4.9			0.193
F			5.8			0.228
G	2.54			0.100		
H			1.2			0.047
I			1.16			0.045
L	45°			45°		

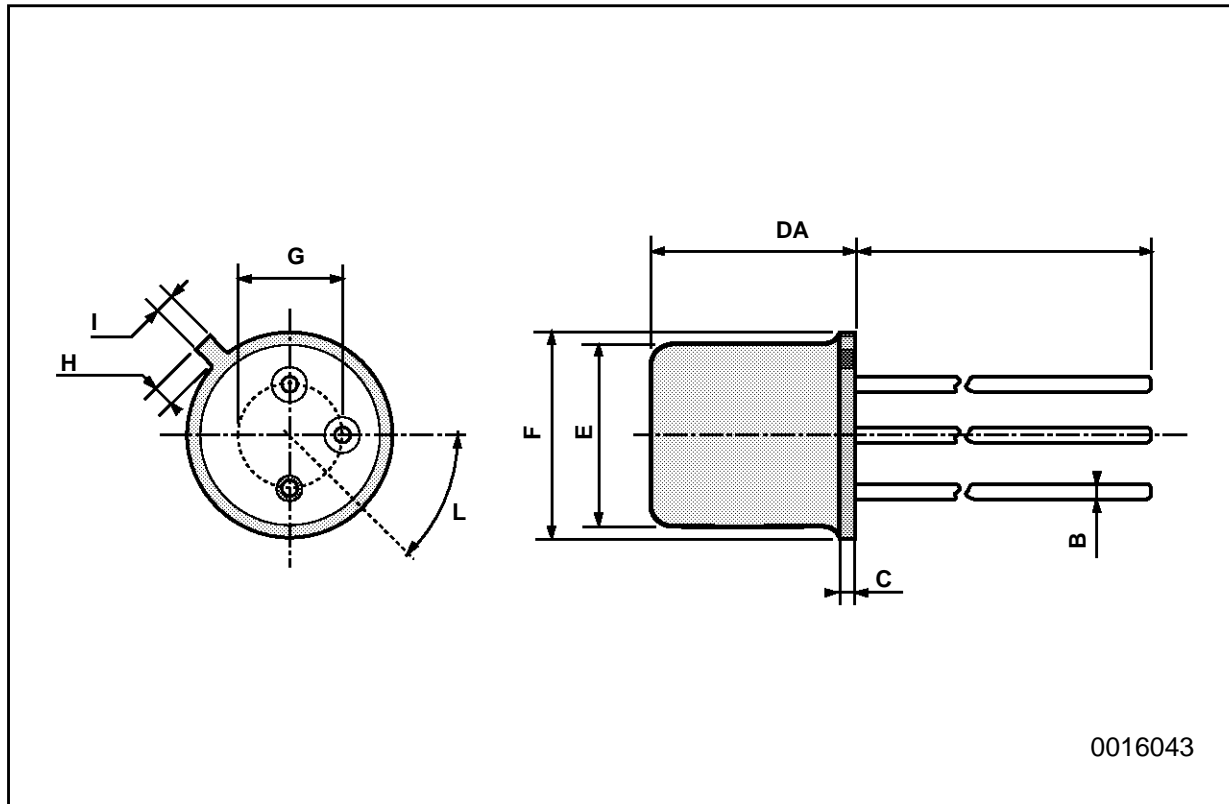

0016043

TO39 MECHANICAL DATA

DIM.	mm			inch		
	MIN.	TYP.	MAX.	MIN.	TYP.	MAX.
A	12.7			0.500		
B			0.49			0.019
D			6.6			0.260
E			8.5			0.334
F			9.4			0.370
G	5.08			0.200		
H			1.2			0.047
I			0.9			0.035
L	45° (typ.)					

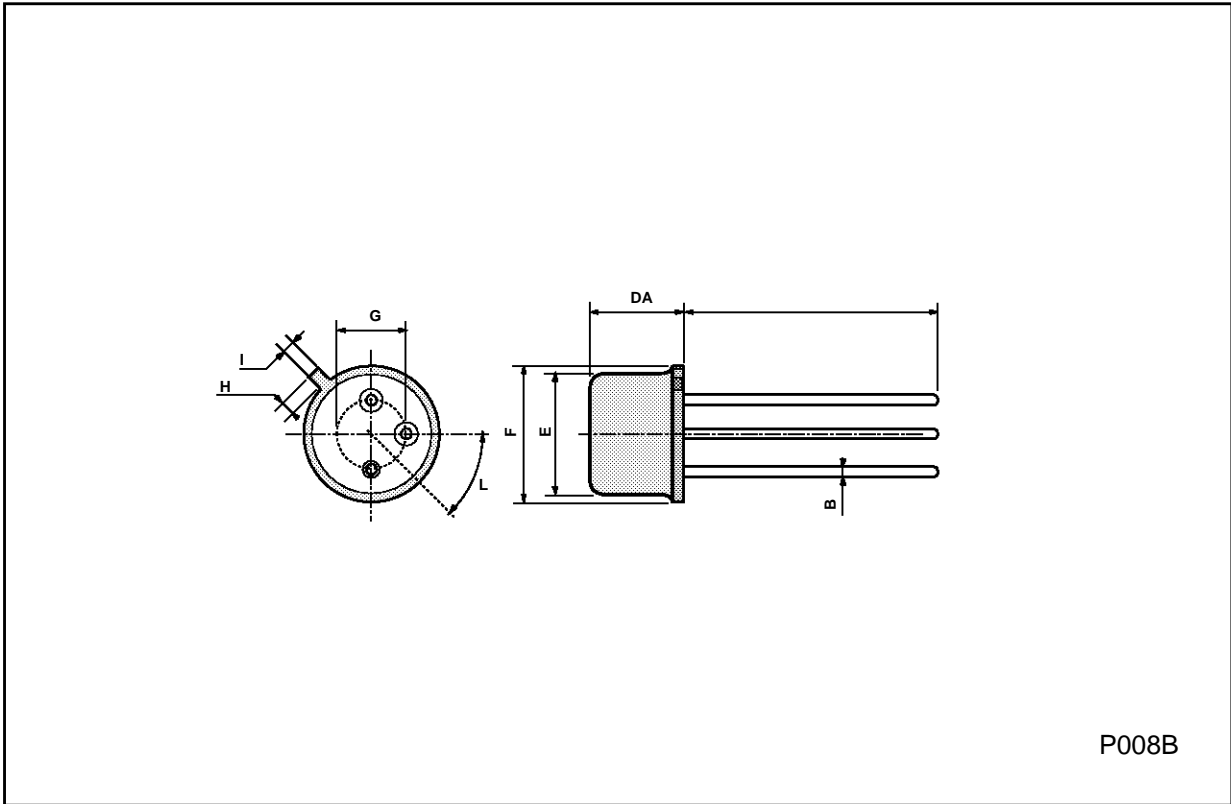

P008B

Information furnished is believed to be accurate and reliable. However, SGS-THOMSON Microelectronics assumes no responsibility for the consequences of use of such information nor for any infringement of patents or other rights of third parties which may result from its use. No license is granted by implication or otherwise under any patent or patent rights of SGS-THOMSON Microelectronics. Specifications mentioned in this publication are subject to change without notice. This publication supersedes and replaces all information previously supplied. SGS-THOMSON Microelectronics products are not authorized for use as critical components in life support devices or systems without express written approval of SGS-THOMSON Microelectronics.

© 1994 SGS-THOMSON Microelectronics - All Rights Reserved

SGS-THOMSON Microelectronics GROUP OF COMPANIES

Australia - Brazil - France - Germany - Hong Kong - Italy - Japan - Korea - Malaysia - Malta - Morocco - The Netherlands -
Singapore - Spain - Sweden - Switzerland - Taiwan - Thailand - United Kingdom - U.S.A