

DO NOT SCALE FROM THIS PRINT

DESIGNED & DIMENSIONED IN MILLIMETERS [INCHES]

QRF8-XXX-XX.X-X-D-XX-A-XX

No OF POSITIONS
-026, -052 & -078
(-018, -036, & -054 FOR -DP ONLY)

LEAD STYLE
-05.0 = 5mm
-07.0 = 7mm

OPTION
-GP: GUIDE POST (SHEET 3, FIG 3) (SEE NOTE 8)
-K: POLYIMIDE FILM PAD
-TR: TAPE & REEL (SEE NOTE 4)

PLATING SPECIFICATION
-L: LIGHT SELECTIVE GOLD / MATTE TIN (USE C-266-XX.X-L & T-1G39-XX.X-L)
-S: SELECTIVE GOLD / MATTE TIN (USE C-266-XX.X-S & T-1G39-XX.X-S)

OPTION
-A: ALIGNMENT PIN
-DP: DIFFERENTIAL PAIRS

ROW SPECIFICATION
-D: DOUBLE VERTICAL

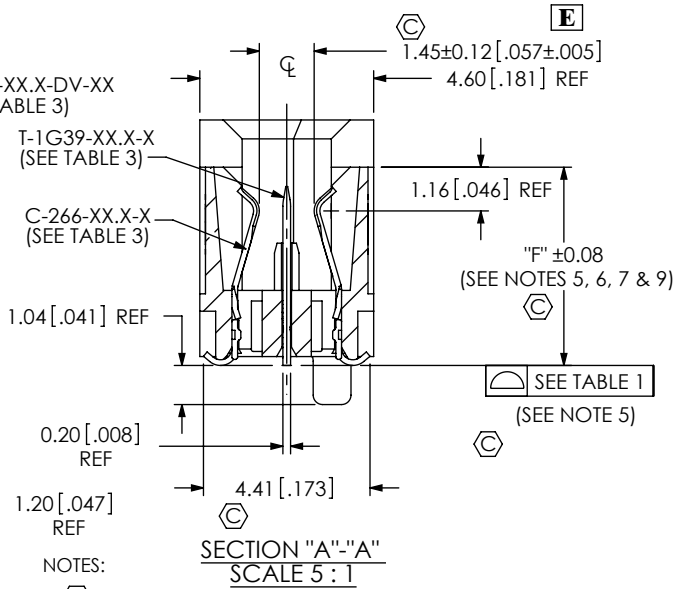
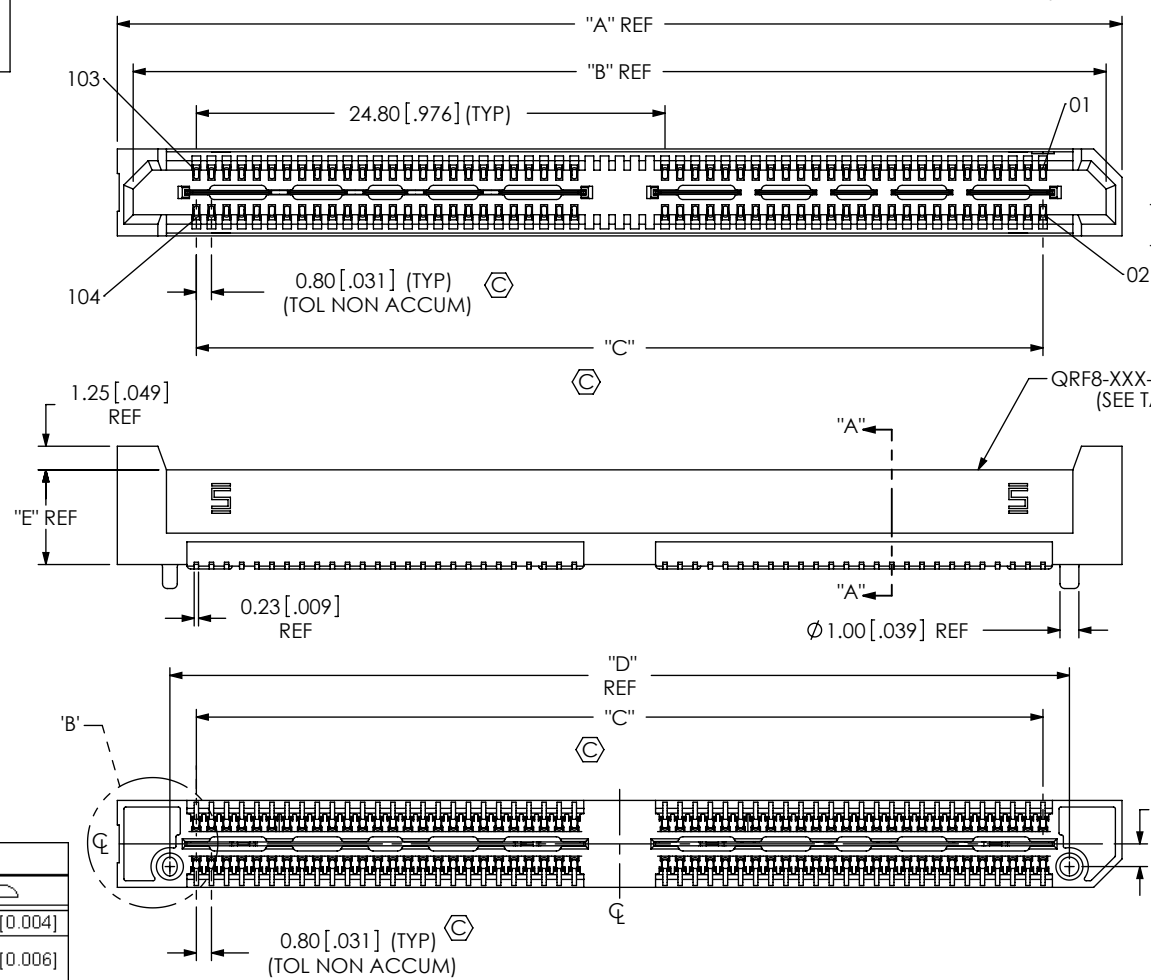

- NOTES:
1. C REPRESENTS A CRITICAL DIMENSION.
 2. BURR ALLOWANCE: 0.038 [.0015] MAX.
 3. MINIMUM PUSHOUT FORCE: SIGNAL: 1.80 N [.4 LB.] GROUND PLANE 4.44 N [1 LB.]
 4. PARTS TO BE PACKAGED IN TRAYS, UNLESS -TR OPTION IS SPECIFIED. -054 & -078 POSITION NOT AVAILABLE IN TAPE AND REEL.
 5. DIMENSION APPLIES TO CONTACTS & GROUND PLANE.
 6. GROUND PLANE PRESS HEIGHT MUST BE .003 [.08] LESS THAN THE MAX HEIGHT OR .001 [.03] GREATER THAN THE MINIMUM HEIGHT OF THE TERMINAL.
 7. MAX VARIANCE OF 0.05 [.002]
 8. PARTS WITH THE -GP OPTION MUST MATE TO -GP OPTIONED QRM8 PARTS AND PARTS WITH NON -GP OPTION MUST MATE TO NON-GP OPTIONED QRM8 PARTS
 9. GROUND PLANE AIR PRESSURE TO BE SET AT 20-25 PSI

No OF POS	C
-018, -026	0.10 [0.004]
-036, -052, -054, -078	0.15 [0.006]

QRF8 LEAD STYLE	QRM8 LEAD STYLE	
	-02.0	-05.0
-05.0	7.0MM	10.0MM
-07.0	9.0MM	12.0MM

LEAD STYLE	QRF8-XXX-XX.X-DV-XX	C-266-XX.X-X	T-1G39-XX.X-X
-05.0	QRF8-XXX-05.0-DV-XX	C-266-05.0-X	T-1G39-05.0-X
-07.0	QRF8-XXX-07.0-DV-XX	C-266-07.0-X	T-1G39-07.0-X

POSITION	"A"	"B"	"C"	"D"
-018, -026	28.37 [1.117]	26.69 [1.051]	20.00 [0.787]	22.80 [0.898]
-036, -052	53.17 [2.093]	51.49 [2.027]	44.80 [1.764]	47.60 [1.874]
-054, -078	77.97 [3.070]	76.29 [3.004]	69.60 [2.740]	72.40 [2.850]

LEAD STYLE	"E"	"F"
-05.0	5.01 [0.197]	5.245 [0.2065]
-07.0	7.01 [0.276]	7.245 [0.2852]

UNLESS OTHERWISE SPECIFIED, DIMENSIONS ARE IN MILLIMETERS [INCHES]. TOLERANCES ARE:
DECIMALS ANGLES
X.X: ±0.3 [.01]
X.XX: ±0.13 [.005]
X.XXX: ±0.050 [.0020]

PROPRIETARY NOTE
THIS DOCUMENT CONTAINS INFORMATION CONFIDENTIAL AND PROPRIETARY TO SAMTEC, INC. AND SHALL NOT BE REPRODUCED OR TRANSFERRED TO OTHER DOCUMENTS OR DISCLOSED TO OTHERS OR USED FOR ANY PURPOSE OTHER THAN THAT WHICH IT WAS OBTAINED WITHOUT THE EXPRESSED WRITTEN CONSENT OF SAMTEC, INC.

520 PARK EAST BLVD. NEW ALBANY, IN 47150
PHONE: 812-944-6733 FAX: 812-948-5047
e-Mail: info@SAMTEC.com code: 55322

MATERIAL: DO NOT SCALE DRAWING SHEET SCALE: 2:1
INSULATOR: LCP, COLOR: BLACK
CONTACT: BeCu
GROUND PLANE: PHOS BRONZE

DESCRIPTION:
.8MM Q-RATE SOCKET ASSEMBLY
DWG. NO.
QRF8-XXX-XX.X-X-D-XX-A-XX

REVISION E

IN PROCESS 1
CUT C-266-XX.X-X CONTACT COMBS

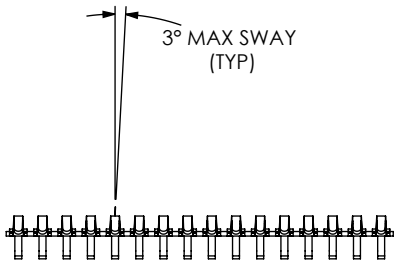

C-266-XX.X-X
(ALL TAILS SAME DIRECTION)

0.11±0.076 [.004±.003]

IN PROCESS 2
FILL C-266-XX.X-X CONTACTS

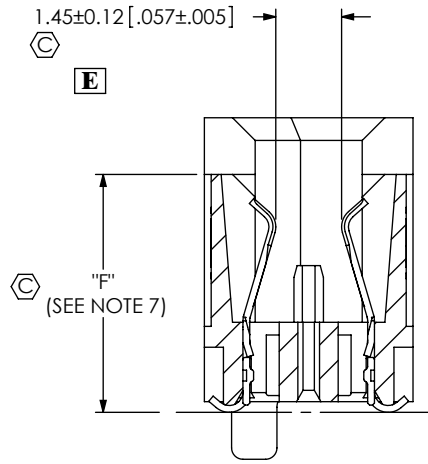

SEE TABLE 1

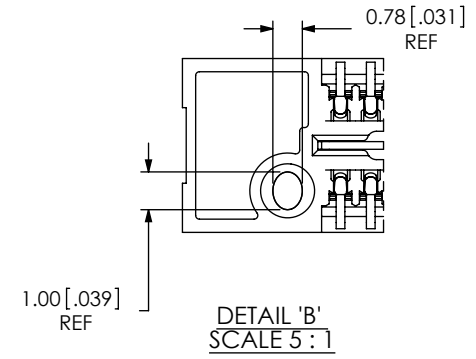

CRITICAL DIMENSION INSPECTION TABLE

ASSEMBLY OPERATION	START UP INSPECTION INSPECT CODE A	IN-PROCESS INSPECTION INSPECT CODE B
IN-PROCESS 1		C9
IN-PROCESS 2		C5, C6
FINISHED GOOD		C1, C2, C3, C4, C5, C6, C7, C8

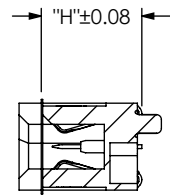
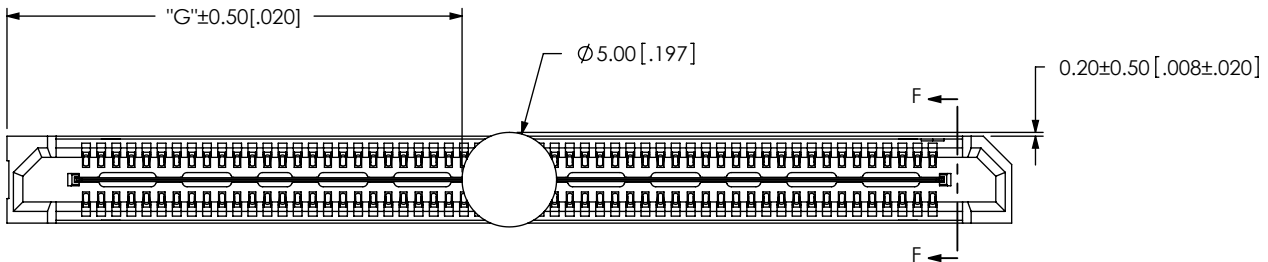

SECTION F-F
SCALE 2.5:1

TABLE 6

POSITION	"G"
-018, -026	11.68 [0.460]
-018 GP, -026 GP	12.52 [0.493]
-036, -052	24.08 [0.948]
-036 GP, -052 GP	24.92 [0.981]
-054, -078	36.49 [1.437]
-054 GP, -078 GP	37.33 [1.470]

TABLE 7

LEAD STYLE	"H"
-05.0	5.372 [0.2115]
-07.0	7.371 [0.2902]

FIG 2
-K OPTION
(USE K-DOT-.197-.344-.005)
(QRF8-052-05.0-X-D-A-K SHOWN)
(SAME AS FIG 1 DIFFERENT AS SHOWN)

PROPRIETARY NOTE
THIS DOCUMENT CONTAINS INFORMATION CONFIDENTIAL AND PROPRIETARY TO SAMTEC, INC. AND SHALL NOT BE REPRODUCED OR TRANSFERRED TO OTHER DOCUMENTS OR DISCLOSED TO OTHERS OR USED FOR ANY PURPOSE OTHER THAN THAT WHICH IT WAS OBTAINED WITHOUT THE EXPRESSED WRITTEN CONSENT OF SAMTEC, INC.

DO NOT SCALE DRAWING
SHEET SCALE: 2:1



520 PARK EAST BLVD. NEW ALBANY, IN 47150
PHONE: 812-944-6733 FAX: 812-948-5047
e-Mail: info@SAMTEC.com code: 55322

DESCRIPTION:
.8MM Q-RATE SOCKET ASSEMBLY

DWG. NO.
QRF8-XXX-XX.X-X-D-XX-A-XX

BY: M MURILLO 7/10/2008 SHEET 2 OF 4

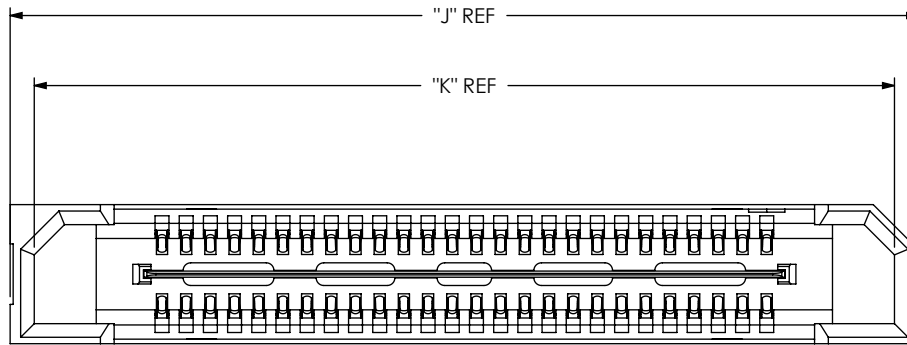

TABLE 8		
POSITION	"J"	"K"
-018, -026	30.05 [1.183]	28.45 [1.120]
-036, -052	54.85 [2.159]	53.25 [2.096]
-054, -078	79.65 [3.136]	78.05 [3.073]

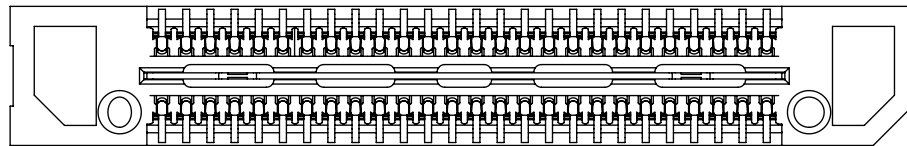
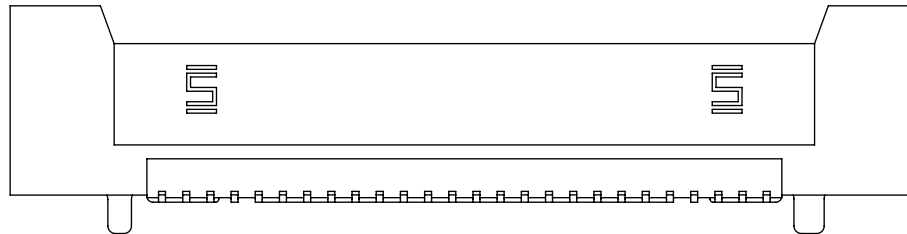
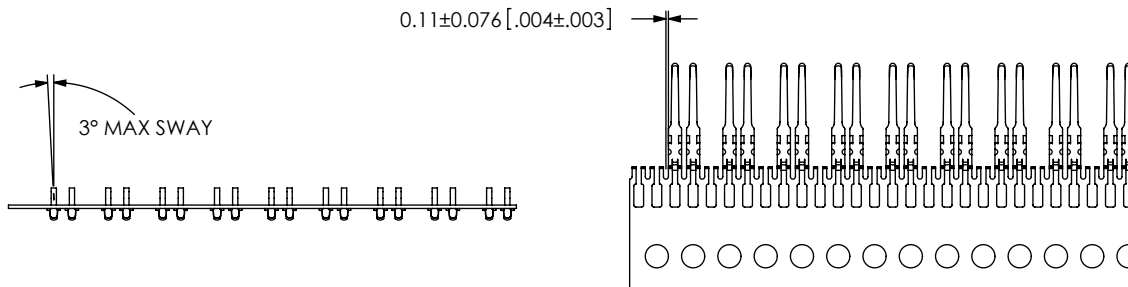

FIG 8
 (QRF8-026-05.0-X-D-A-GP SHOWN)
 (SAME AS FIG 2 DIFFERENT AS SHOWN)
 SCALE 4:1



IN PROCESS 3
 CUT C-266-XX.X-X CONTACT COMBS
 (FOR QRF8-018-05.0-X-D-DP-A-GP)

PROPRIETARY NOTE
 THIS DOCUMENT CONTAINS INFORMATION
 CONFIDENTIAL AND PROPRIETARY TO
 SAMTEC, INC. AND SHALL NOT BE REPRODUCED
 OR TRANSFERRED TO OTHER DOCUMENTS OR
 DISCLOSED TO OTHERS OR USED FOR ANY
 PURPOSE OTHER THAN THAT WHICH IT WAS
 OBTAINED WITHOUT THE EXPRESSED WRITTEN
 CONSENT OF SAMTEC, INC.

DO NOT SCALE DRAWING

SHEET SCALE: 4:1



520 PARK EAST BLVD, NEW ALBANY, IN 47150
 PHONE: 812-944-6733 FAX: 812-948-5047
 e-Mail: info@SAMTEC.com code: 55322

DESCRIPTION:
 .8MM Q-RATE SOCKET ASSEMBLY

DWG. NO.
 QRF8-XXX-XX.X-X-D-XX-A-XX

BY: M MURILLO 7/10/2008 SHEET 3 OF 4

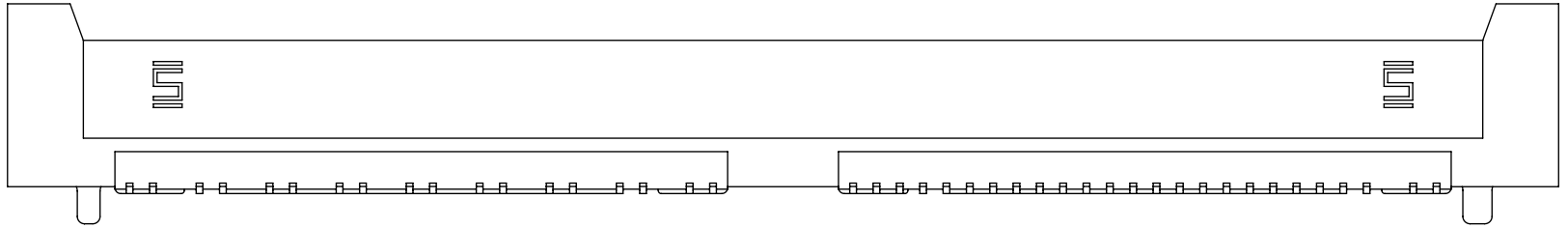
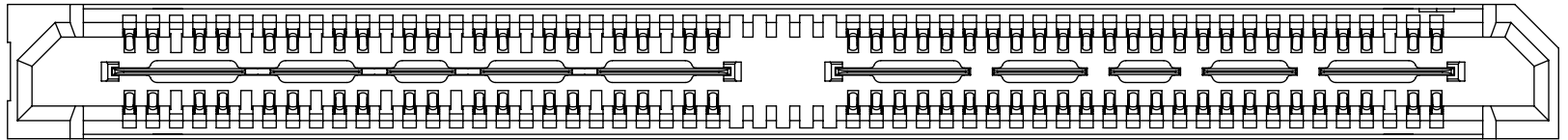
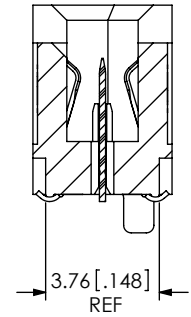
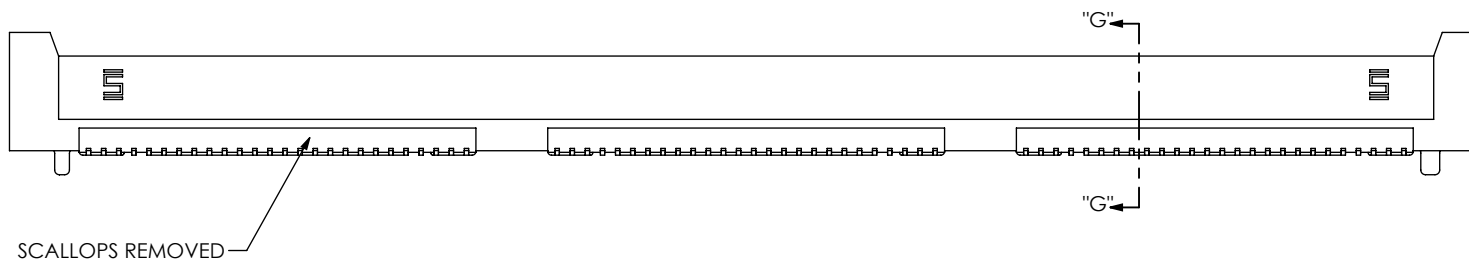

FIG 9
(QRF8-036-05.0-X-D-DP-A-GP SHOWN)
(SAME AS FIG 8 DIFFERENT AS SHOWN)
SCALE 4:1



SECTION "G"-"G"

FIG 10
(QRF8-078-05.0-X-D-A SHOWN)
(DIFFERENT AS SHOWN FOR ALL 3 BANK ASSEMBLIES)
SCALE 4:1

<p>PROPRIETARY NOTE</p> <p>THIS DOCUMENT CONTAINS INFORMATION CONFIDENTIAL AND PROPRIETARY TO SAMTEC, INC. AND SHALL NOT BE REPRODUCED OR TRANSFERRED TO OTHER DOCUMENTS OR DISCLOSED TO OTHERS OR USED FOR ANY PURPOSE OTHER THAN THAT WHICH IT WAS OBTAINED WITHOUT THE EXPRESSED WRITTEN CONSENT OF SAMTEC, INC.</p> <p>DO NOT SCALE DRAWING</p> <p>SHEET SCALE: 4:1</p>		
	<p>520 PARK EAST BLVD. NEW ALBANY, IN 47150 PHONE: 812-944-6733 FAX: 812-948-5047 e-Mail: info@SAMTEC.com code: 55322</p>	
	<p>DESCRIPTION: .8MM Q-RATE SOCKET ASSEMBLY</p>	
	<p>DWG. NO. QRF8-XXX-XX.X-X-D-XX-A-XX</p>	
<p>BY: M MURILLO 7/10/2008</p>		<p>SHEET 4 OF 4</p>