



# AK1222

## 900MHz Low Power Mixer

### 1. Overview

The AK1222 is a low power mixer. RF and LO frequency range coverage from 100 to 900MHz and IF coverage is from 20 to 100MHz. The RF input provides single-ended 50 $\Omega$  interface. LO ports are 50 $\Omega$  matched and complementary inputs should be decoupled to the ground. IF output ports are differential open drain outputs.

The linearity and power consumption performances can optimize with the resistance connected to the BIAS pin.

### 2. Features

- Operating Frequency: 100 to 900MHz
- Linearity vs Power Selectable architecture
  - Power Consumption:5.3mA, IIP3:+11dBm, Gain:-2dB, NF:12dB
  - Power Consumption:2.9mA, IIP3:+2dBm, Gain:-3.5dB, NF:11.5dB
- LO input level: 0dBm $\pm$ 5dB
- Operating Supply Voltage: 4.75 to 5.25 V
- Package: 16pin UQFN (0.5mm pitch, 3mm x 3mm x 0.60mm)
- Operating Temperature Range: -40 to 85 $^{\circ}$ C

**Table of Contents**

<b>1. Overview</b>	<b>1</b>
<b>2. Features</b>	<b>1</b>
<b>3. Block Diagram</b>	<b>3</b>
<b>4. System Diagram</b>	<b>4</b>
<b>5. Pin Functional Description</b>	<b>5</b>
<b>6. Absolute Maximum Ratings</b>	<b>7</b>
<b>7. Recommended Operating Range</b>	<b>7</b>
<b>8. Electrical Characteristics</b>	<b>8</b>
<b>9. Typical Performance</b>	<b>9</b>
<b>10. Typical Evaluation Board Schematic</b>	<b>16</b>
<b>11. IC Interface Schematic</b>	<b>24</b>
<b>12. Outer Dimensions</b>	<b>25</b>
<b>13. Marking</b>	<b>26</b>

3. Block Diagram

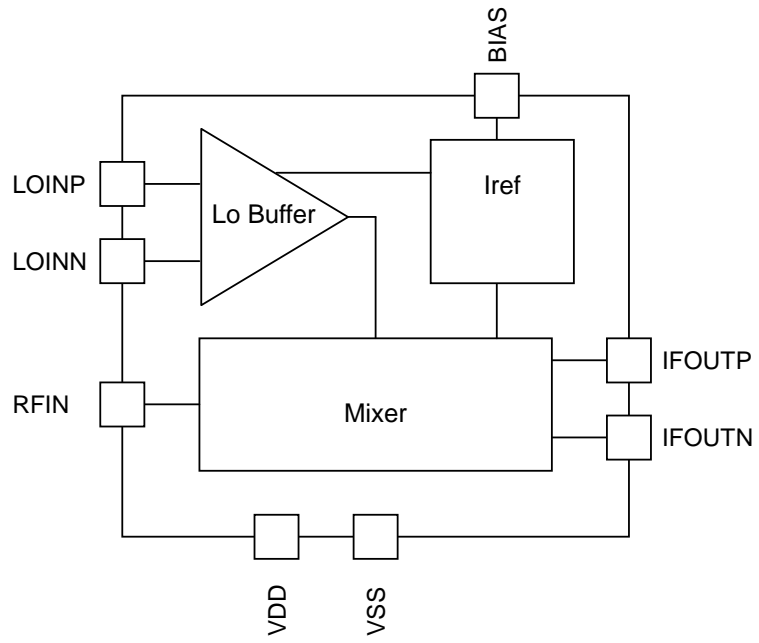
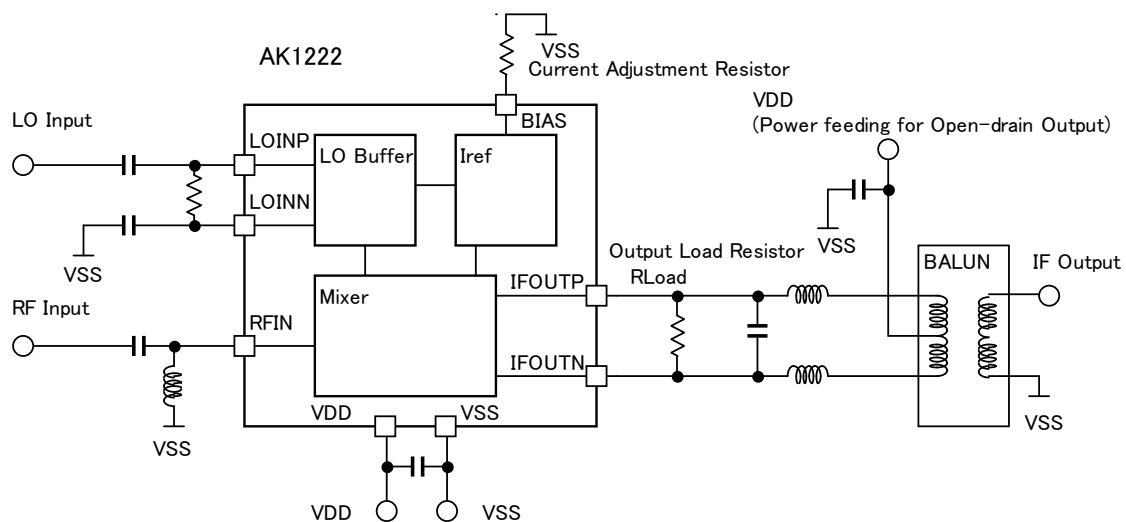

Fig. 1 Block Diagram

**4. System Diagram**



**Fig. 2 System Diagram**

<b>5. Pin Functional Description</b>
--------------------------------------

Table 1 Pin Function

No.	Name	I/O	Pin Functions	Remarks
1	RFIN	AI	RF Input	Connecting an inductor between this pin and ground.
2	VSS	G	Ground pin	
3	LOINN	AI	LO Input Negative	
4	LOINP	AI	LO Input Positive	
5	NC	-	Non Connect	
6	NC	-	Non Connect	
7	NC	-	Non Connect	
8	NC	-	Non Connect	
9	BIAS	AIO	Resistance pin for current adjustment	Connecting a resistor between this pin and ground.
10	VDD	P	Power Supply	
11	IFOUTN	AO	IF Output Negative	This pin is open drain output. It needs power feeding via an inductor.
12	IFOUTP	AO	IF Output Positive	This pin is open drain output. It needs power feeding via an inductor.
13	NC	-	Non Connect	
14	NC	-	Non Connect	
15	NC	-	Non Connect	
16	NC	-	Non Connect	

Note) It is recommended to connect NC pins to ground, although it will not make any impact on the electrical characteristics if the pin is open.

AI: Analog input pin	AO: Analog output pin	AIO: Analog I/O pin
P: Power supply pin	G: Ground pin	

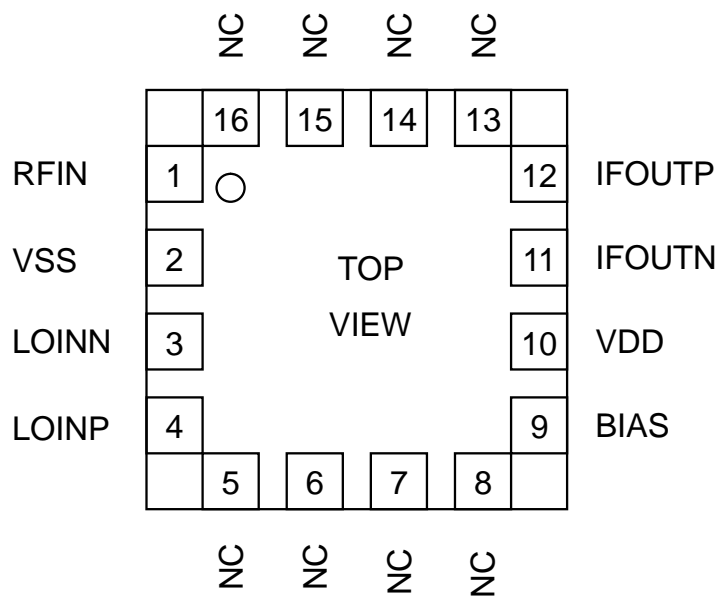

Fig. 3 Package Pin Layout

## 6. Absolute Maximum Ratings

**Table 2 Absolute Maximum Ratings**

Parameter	Symbol	Min.	Max.	Unit	Remarks
Supply Voltage	VDD	-0.3	5.5	V	
RF Input Power	RFPOW		7	dBm	
LO Input Power	LOPOW		12	dBm	
Storage Temperature	Tstg	-55	125	°C	

Exceeding these maximum ratings may result in damage to the AK1222. Normal operation is not guaranteed at these extremes.

## 7. Recommended Operating Range

**Table 3 Recommended Operating Range**

Parameter	Symbol	Min.	Typ.	Max.	Unit	Remarks
Operating Temperature	Ta	-40		85	°C	
Supply Voltage	VDD	4.75	5	5.25	V	

The specifications are applicable within the recommended operating range (supply voltage/operating temperature).

## 8. Electrical Characteristics

### 1. Analog Circuit Characteristics

Unless otherwise noted IF output=50MHz, LO Input Level=-5dBm to +5dBm,

Output Load Resistor (R<sub>Load</sub>)=2.2k $\Omega$ , VDD=4.75 to 5.25V, Ta=-40 to 85°C

Parameter		Min.	Typ.	Max.	Unit	Remarks
RF Input Frequency		100		900	MHz	
LO Input Frequency		100		900	MHz	
IF output Frequency		20		100	MHz	
LO Input Power		-5	0	+5	dBm	
Current Adjustment Resistor(BIAS)		22		56	k $\Omega$	
IDD	BIAS=22k $\Omega$		5.3	7.9	mA	The total current of VDD pin, IFOUTP pin and IFOUTN pin.
	BIAS=56k $\Omega$		2.9	4.7	mA	
<b>RFIN=600MHz, Output Load Resistor = 22k<math>\Omega</math></b>						
Conversion Gain		-4	-2	0	dB	
SSB Noise Figure (NF)			12	14	dB	Design guarantee value
IP1dB		-3	0		dBm	
IIP3		+8	+11		dBm	
<b>RFIN=600MHz, Output Load Resistor = 56k<math>\Omega</math></b>						
Conversion Gain		-5.5	-3.5	-1.5	dB	
SSB Noise Figure (NF)			11.5	13.5	dB	Design guarantee value
IP1dB		-9	-6		dBm	
IIP3		-1	+2		dBm	

Note 1) In the shipment test, NC pins and the exposed pad on the center of the back of the package is connected to ground.



### 9. Typical Performance

Unless otherwise noted, RF input =600MHz, LO input =550MHz, IF output =50MHz,

Output Load Resistor (R<sub>Load</sub>)=2.2k $\Omega$

#### 1. Current Adjustment Resistor vs. IIP3, NF, IP1dB, Gain, IDD

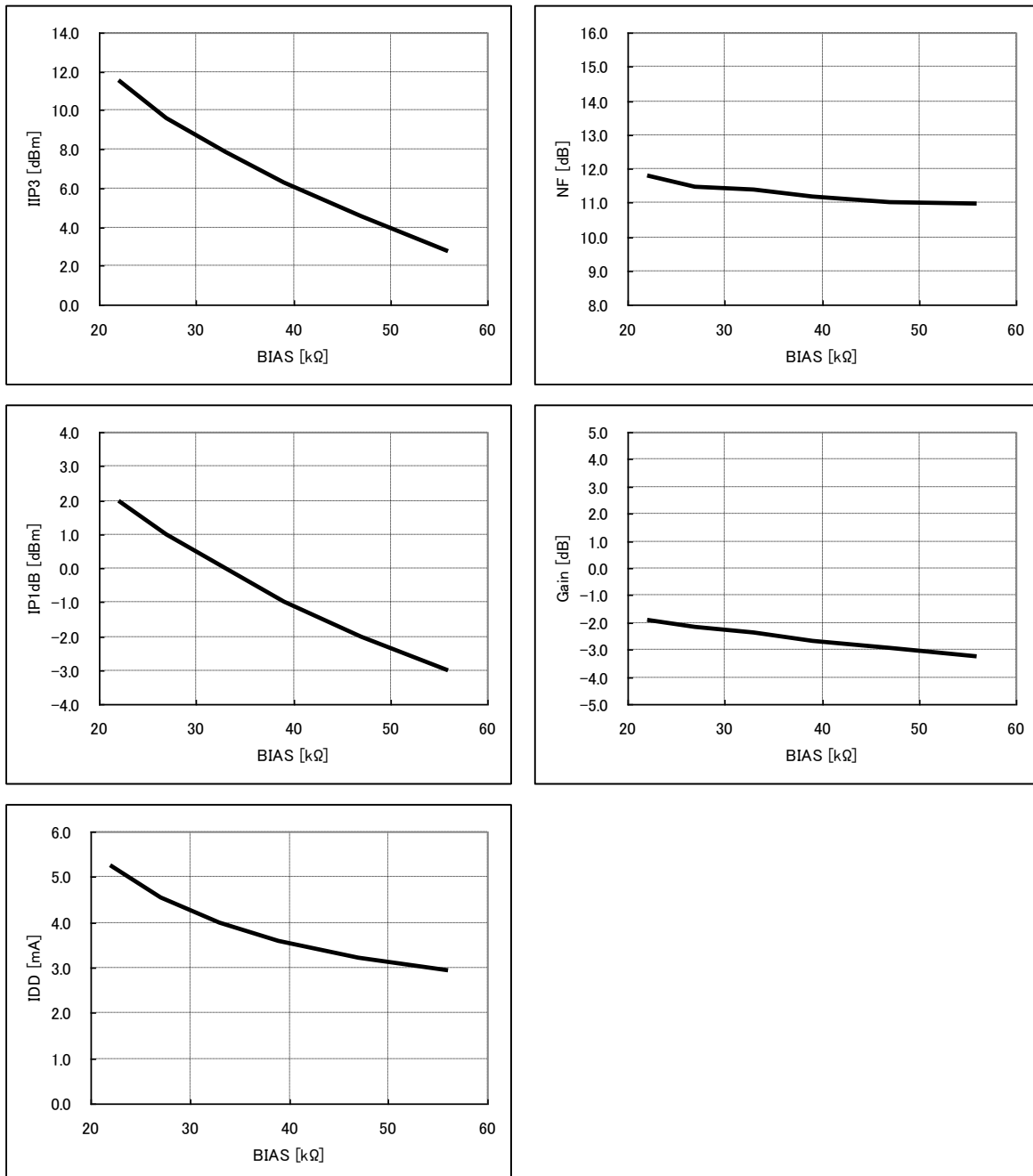

**Fig. 4 Current Adjustment Resistor vs. IIP3, NF, IP1dB, Gain, IDD**

Note 1) A resistor with 5% tolerance are used.

2. Over temperature vs. IIP3, NF, IP1dB, Gain, IDD

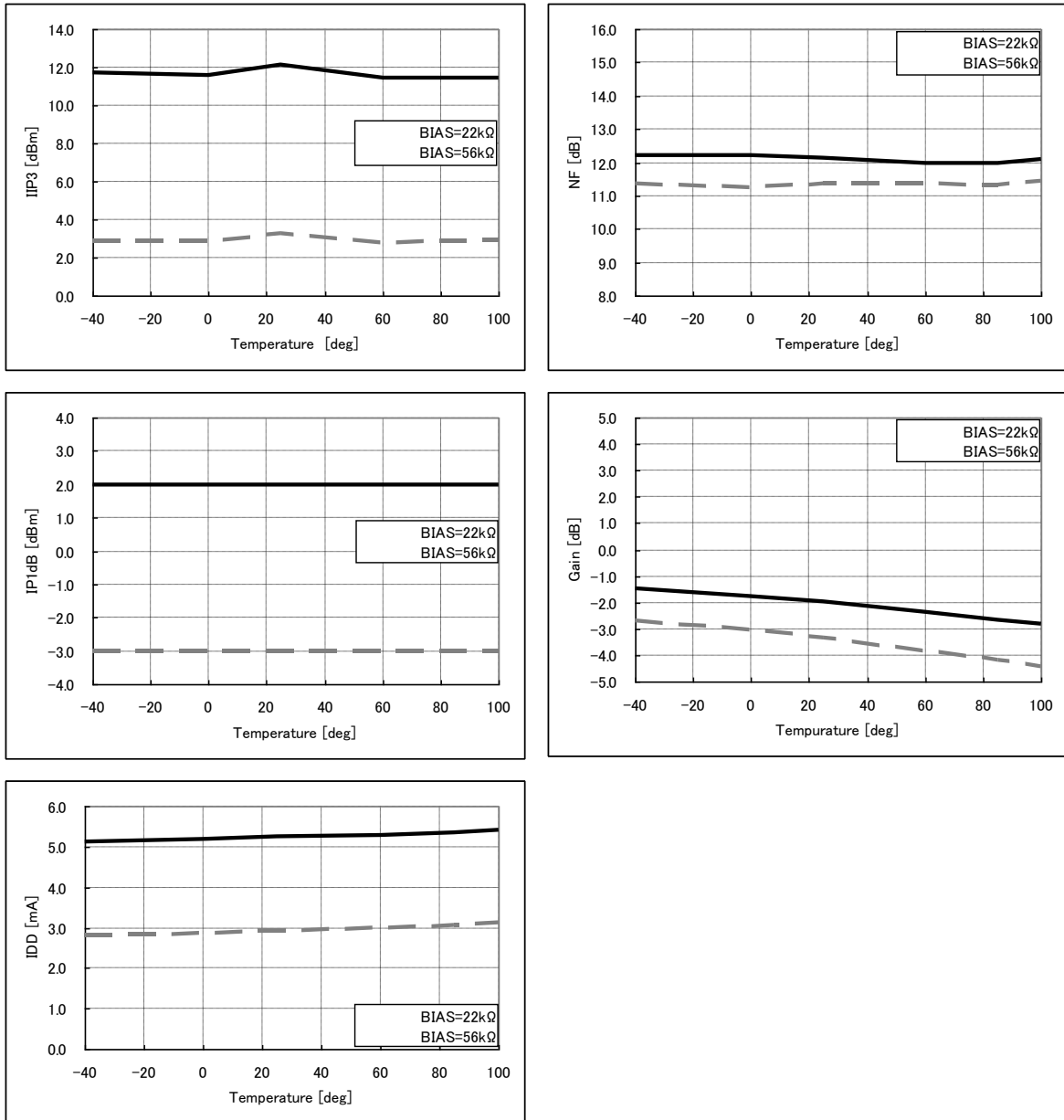

Fig. 5 Over temperature vs. IIP3, NF, IP1dB, Gain, IDD

3. Supply voltage vs. IIP3, NF, IP1dB, Gain, IDD

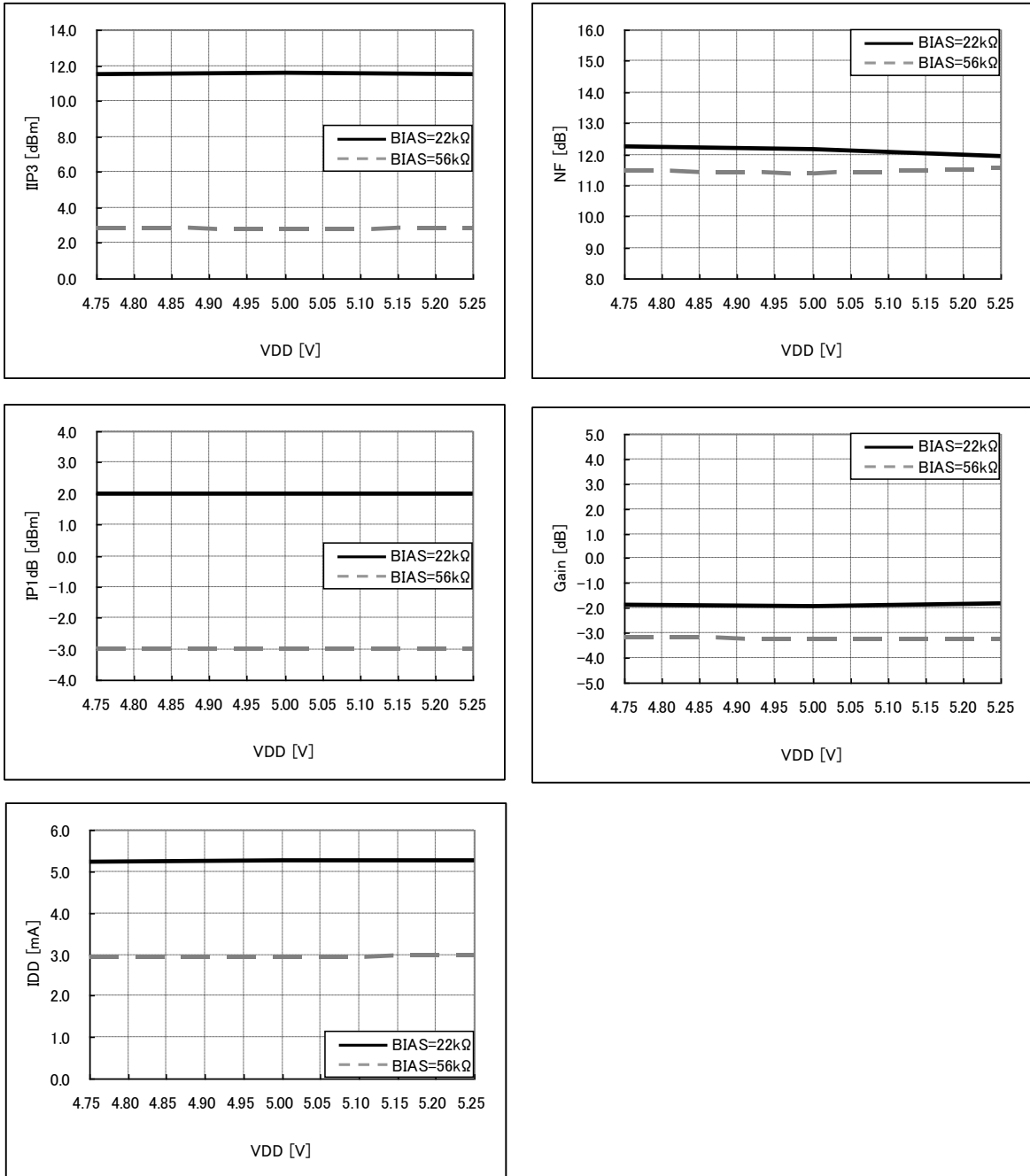

Fig. 6 Supply voltage vs. IIP3, NF, IP1dB, Gain, IDD

4. RF input frequency vs. IIP3, NF, IP1dB, Gain

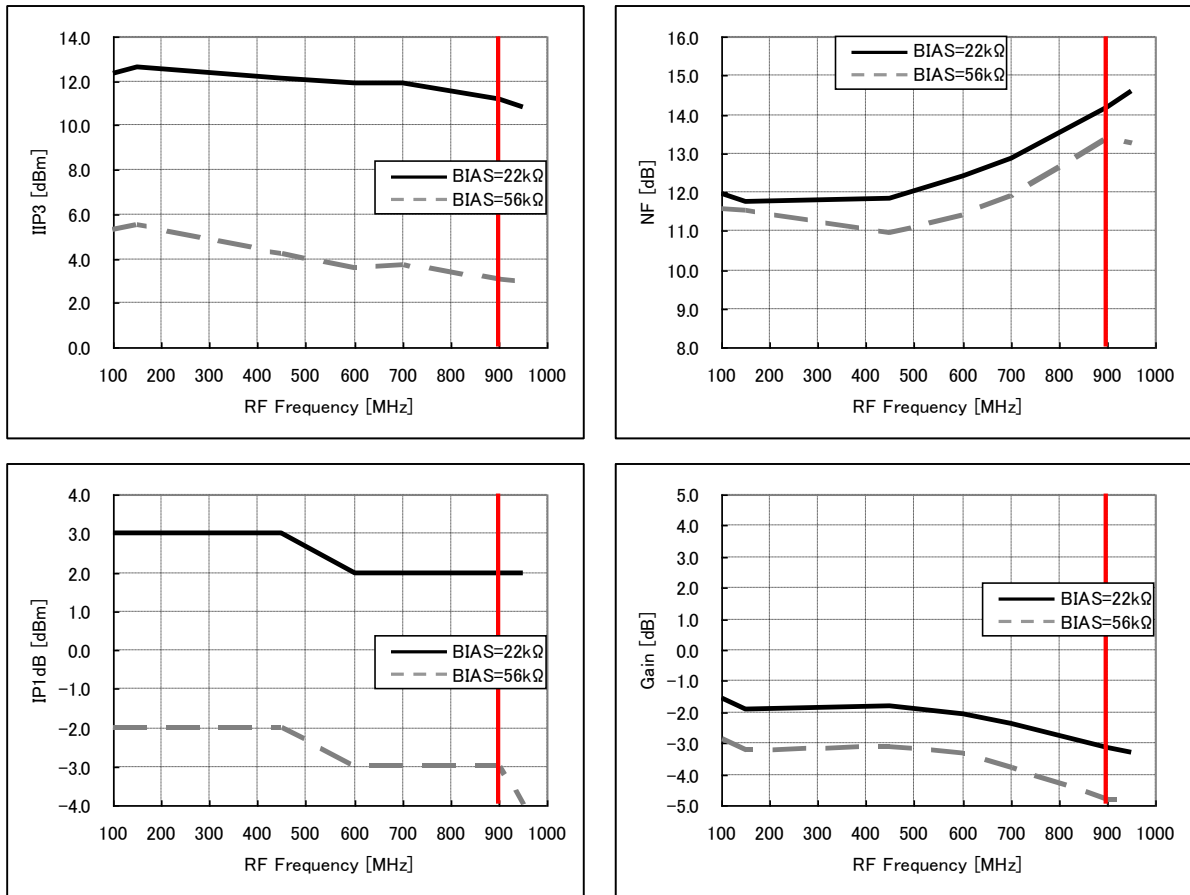

Fig. 7 RF input frequency vs. IIP3, NF, IP1dB, Gain

Note 1) AK1222 supports 100MHz to 900MHz RF Input.

5. IF output frequency vs. IIP3, NF, IP1dB, Gain

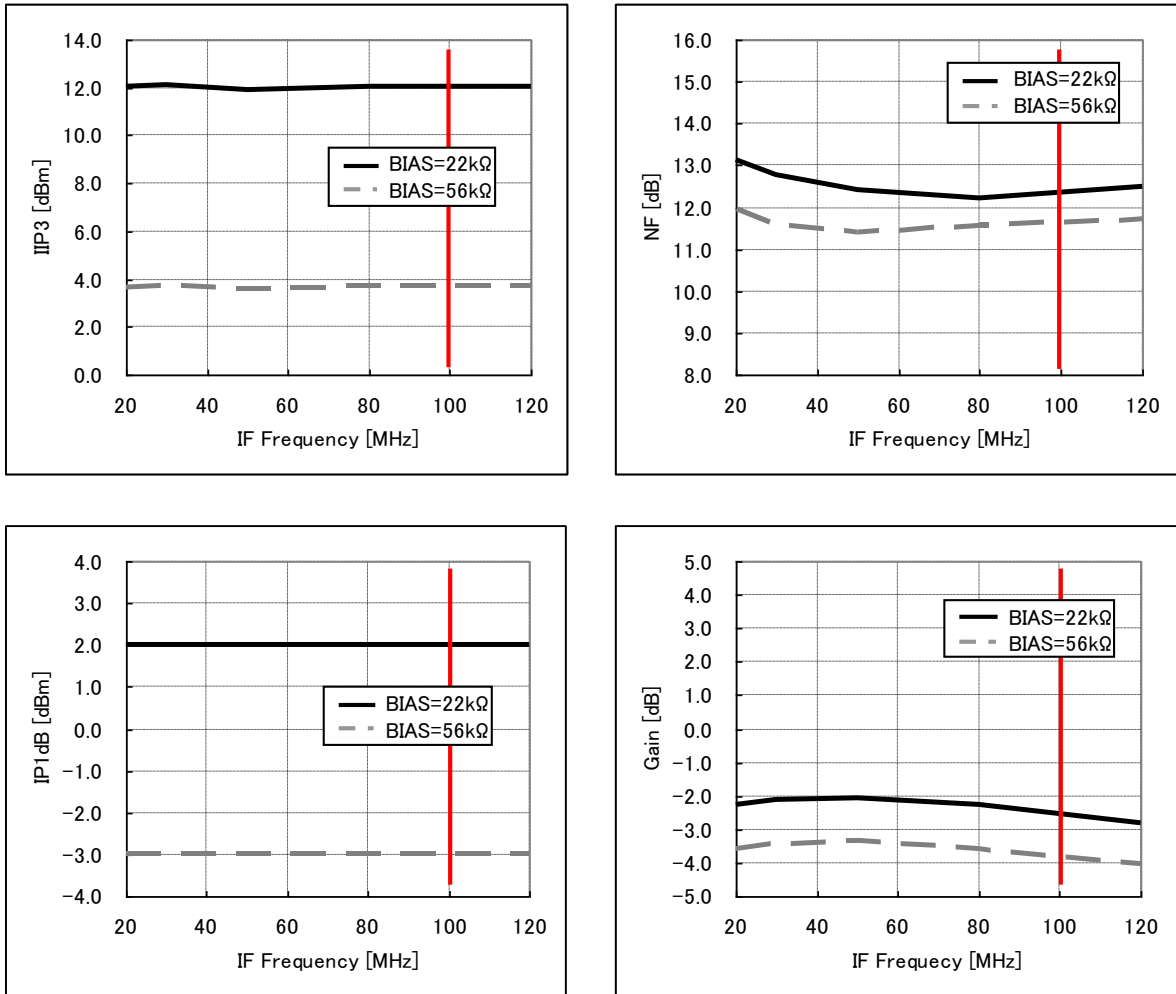

Fig. 8 IF output frequency vs. IIP3, NF, IP1dB, Gain

Note 1) AK1222 supports 20MHz to 100MHz IF Output.

6. LO input power vs. IIP3, NF, IP1dB, Gain

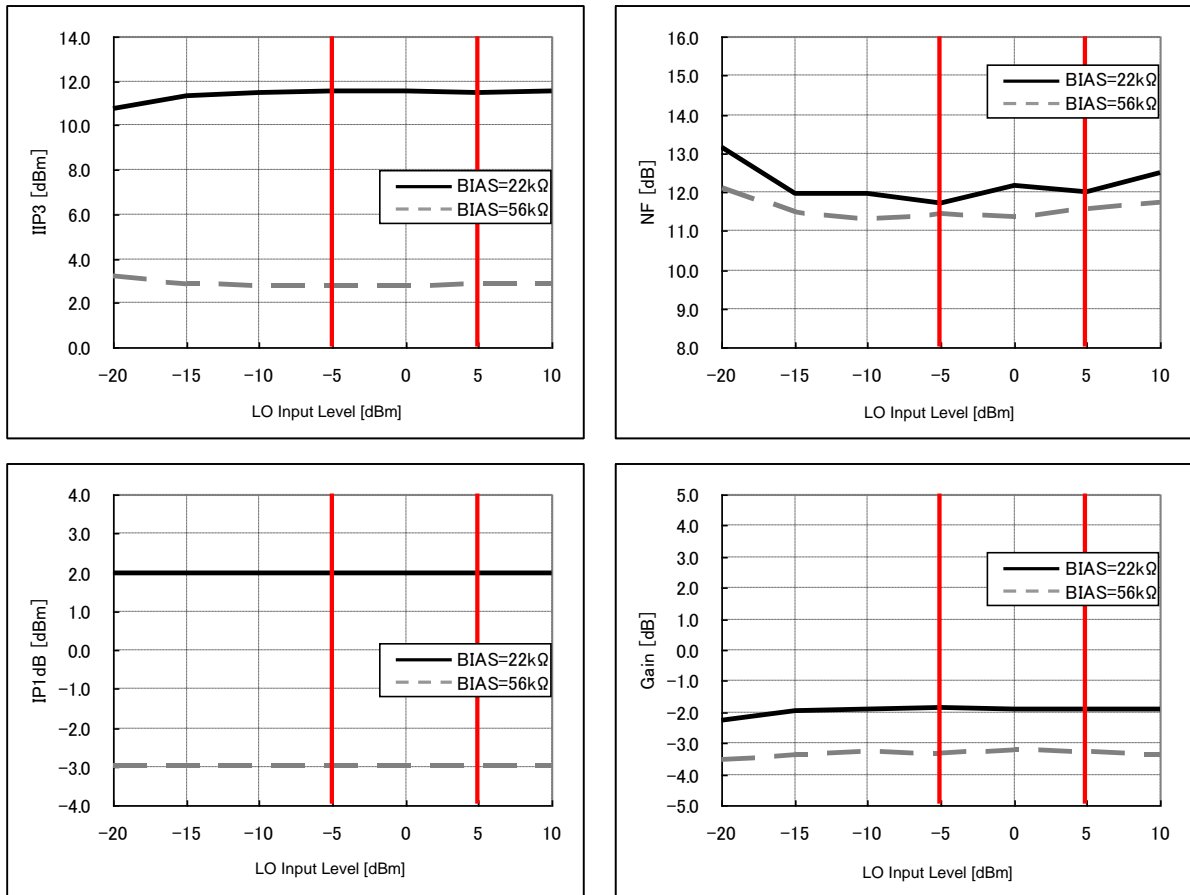

Fig. 9 LO input power vs. IIP3, NF, IP1dB, Gain

Note 1) AK1222 supports -5dBm to 5dBm LO input power.

7. Output Load Resistor (RLoad) vs. IIP3, NF, IP1dB, Gain

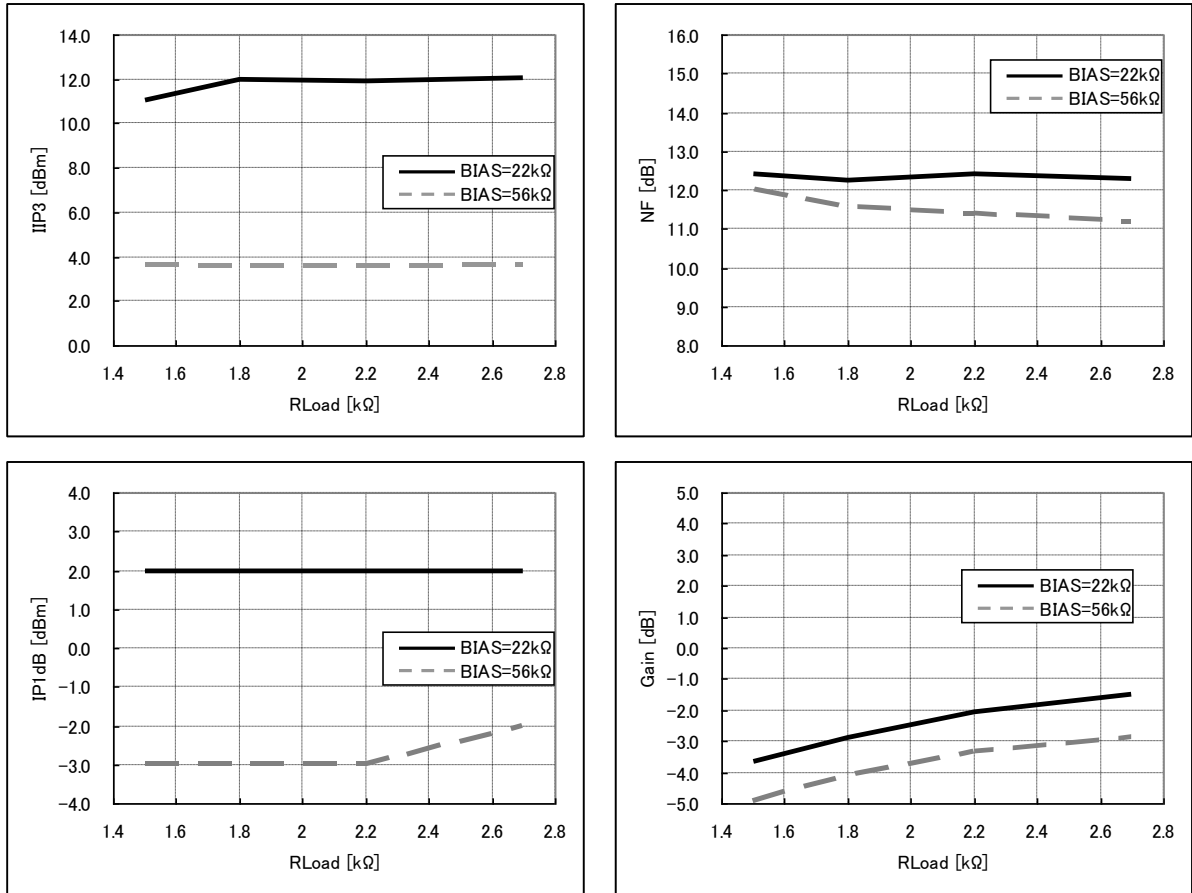

Fig. 10 Output Load Resistor (RLoad) vs. IIP3, NF, IP1dB, Gain

8. Leakage

RF input=600MHz, -20dBm, LO input=600MHz, 0dBm, Ta=25°C VDD=5V

Parameter	BIAS	Typ.	Unit
RF – LO Leakage	22kΩ	-50	dBc
	56kΩ	-50	dBc
RF – IF Leakage	22kΩ	-80	dBc
	56kΩ	-80	dBc
LO – RF Leakage	22kΩ	-50	dBc
	56kΩ	-50	dBc
LO – IF Leakage	22kΩ	-80	dBc
	56kΩ	-80	dBc

**10. Typical Evaluation Board Schematic**

**1. Typical Evaluation Board Schematic**

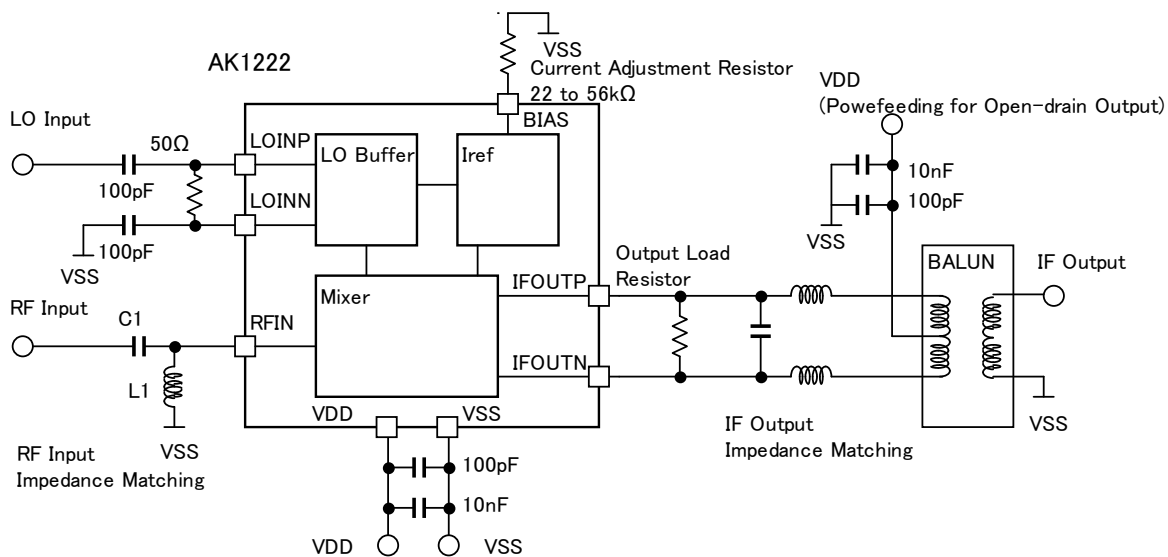

**Fig. 11 Typical Evaluation Board Schematic**

Note 1) The open drain output needs power feeding via a inductor. (IFOUTP pin and IFOUTN)

Note 2) It is necessary to adjust impedance matching as to its setting frequency. (RF input and IF output)



2. Example of impedance matching

•RFIN

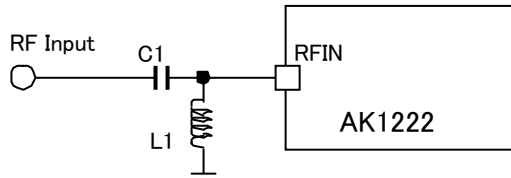

Frequency[MHz]	C1[pF]	L1[nH]
150	15	82
450	5.1	22
600	3.6	15
900	3.9	6.8

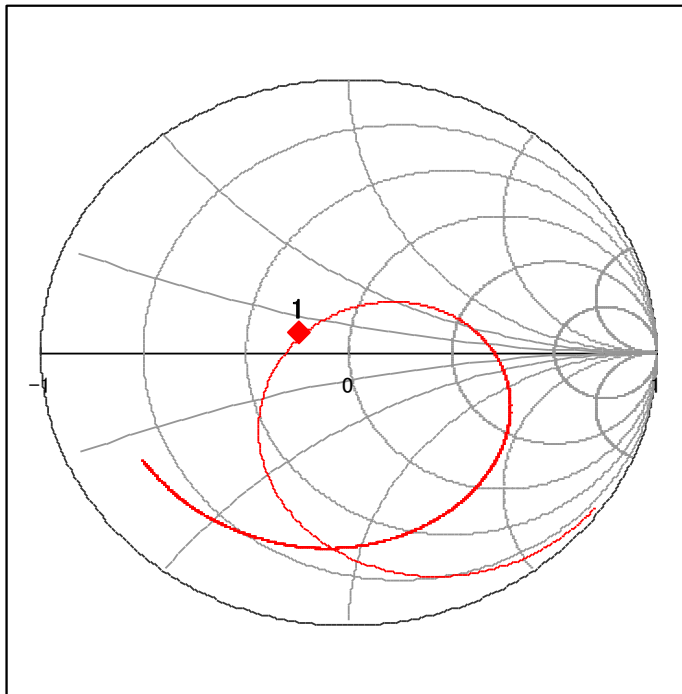

Frequency[MHz]	C1[pF]	L1[nH]
150	15	82

Start 50MHz, Stop 1GHz

Marker 1

150MHz: 36.1Ω 4.2Ω

Fig. 12 RFIN 150MHz example of impedance matching

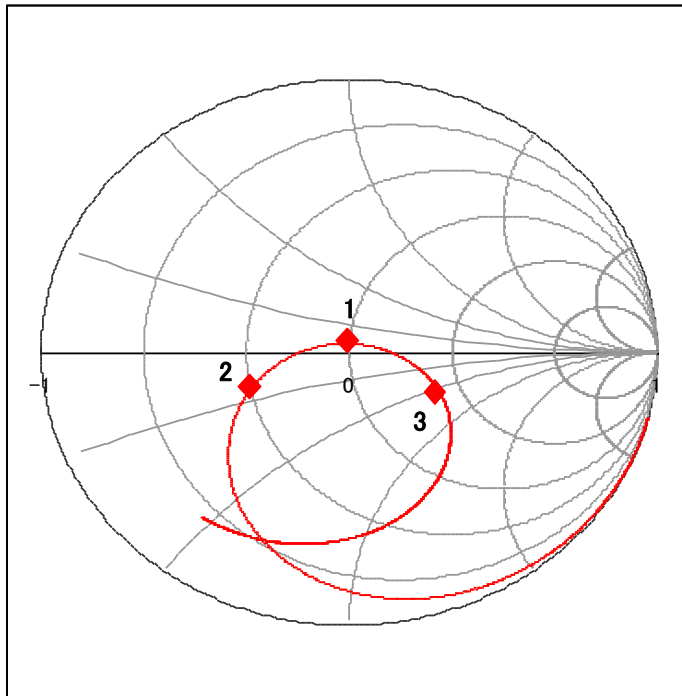

Frequency[MHz]	C1[pF]	L1[nH]
450	5.1	22

Start 50MHz, Stop 1GHz

Marker 1

450MHz: 51.1Ω 3.3Ω

Marker 2

394MHz: 25.1Ω -7.6Ω

Marker 3

524MHz: 85.6Ω -30.1Ω

Fig. 13 RFIN 450MHz example of impedance matching

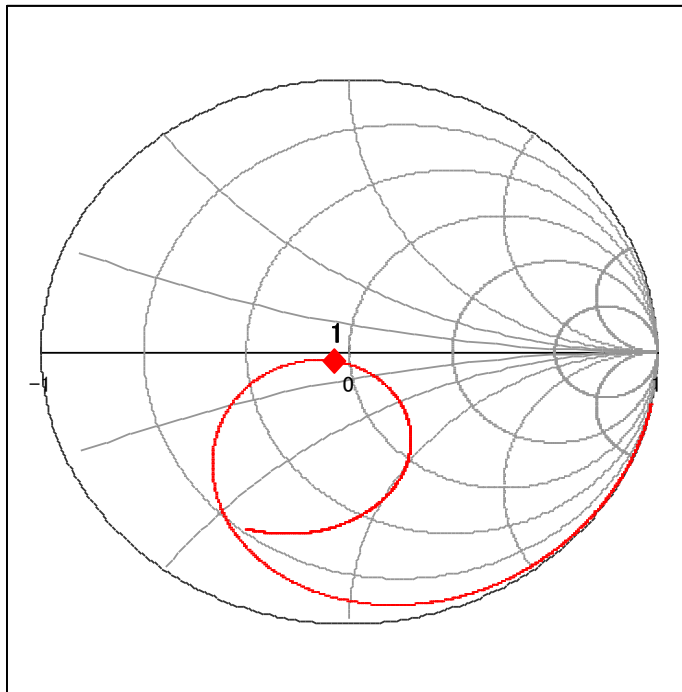

Frequency[MHz]	C1[pF]	L1[nH]
600	3.6	15

Start 50MHz, Stop 1GHz

Marker 1

600MHz: 46.2Ω -3.3Ω

Fig. 14 RFIN 600MHz example of impedance matching

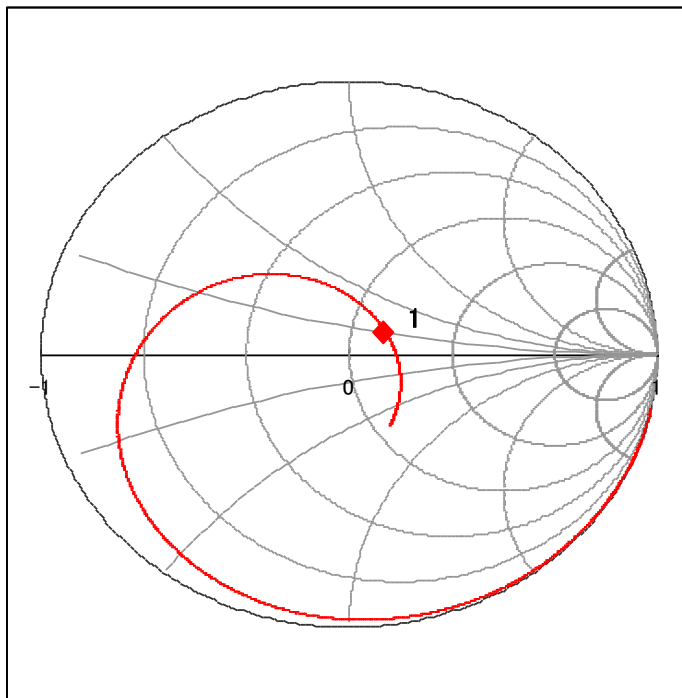

Frequency[MHz]	C1[pF]	L1[nH]
900	3.9	6.8

Start 50MHz, Stop 1GHz

Marker 1

900MHz: 61.8Ω 11.0Ω

**Fig. 15 RFIN 900MHz example of impedance matching**

•IFOUT

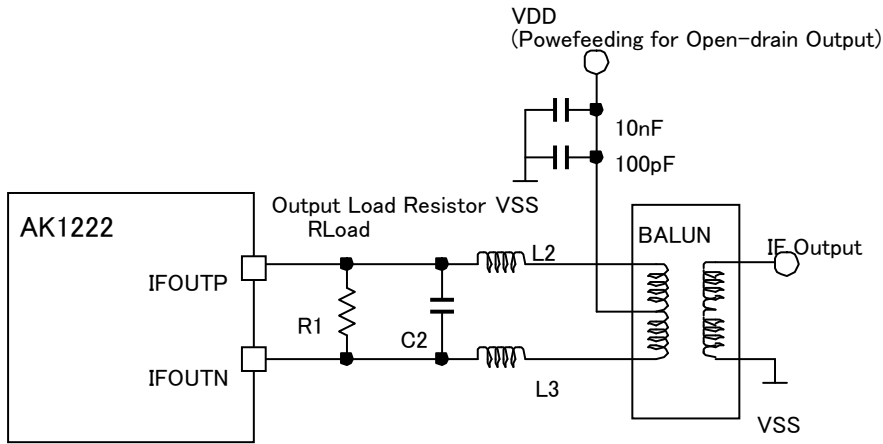

Frequency [MHz]	R1 [kΩ]	C2 [pF]	L2 [nH]	L3 [nH]
30	2.2	3.9	1800	1800
50	2.2	2.0	1000	1000
60	2.2	0.5	1000	1000
80	2.2	N/A	680	680
100	2.2	N/A	470	470

1800nH : Murata LQW21HN1R8J00L  
 1000nH : Murata LQW21HN1R0J00L  
 680nH : Murata LQW21HNR68J00L  
 470nH : Murata LQW21HNR47J00L  
 BALUN:Mini-Circuits ADT4-6T+

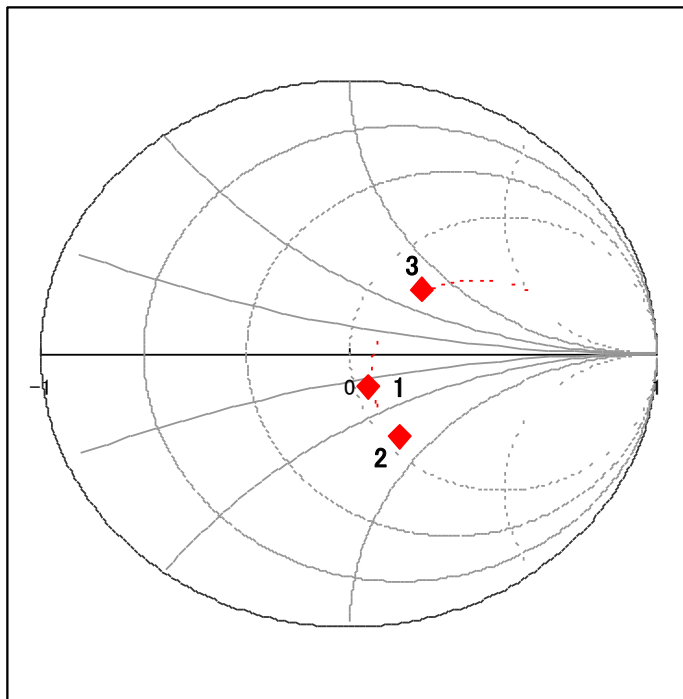

Frequency [MHz]	R1 [kΩ]	C2 [pF]	L2 [nH]	L3 [nH]
30	2.2	3.9	1800	1800

Start 10MHz, Stop 140MHz

- Marker 1  
30MHz: 55.5Ω -19.7Ω
- Marker 2  
28MHz: 55.7Ω -37.3Ω
- Marker 3  
36MHz: 72.8Ω 38.4Ω

Fig. 16 IFOUT 30MHz example of impedance matching

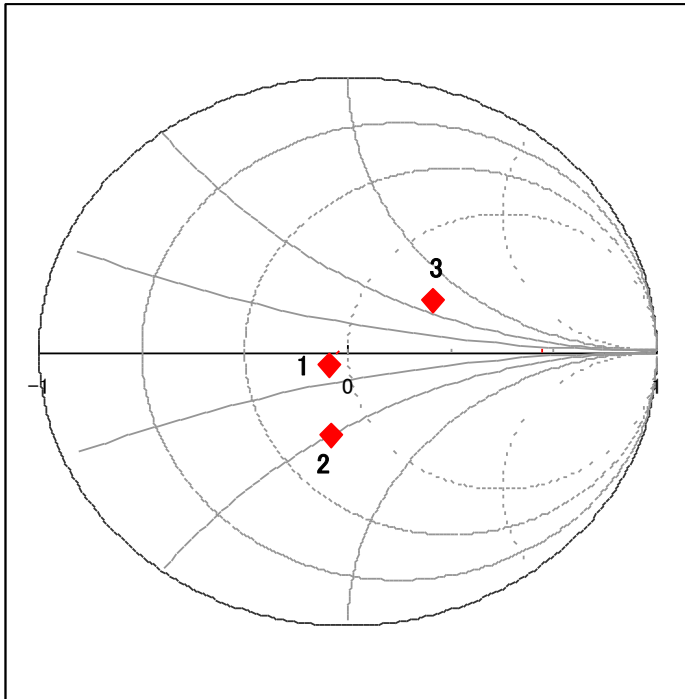

Frequency [MHz]	R1 [kΩ]	C2 [pF]	L2 [nH]	L3 [nH]
50	2.2	2	1000	1000

Start 10MHz, Stop 140MHz

Marker 1

50MHz: 43.2Ω -7.5Ω

Marker 2

45MHz: 37.3Ω -28.6Ω

Marker 3

59MHz: 81.6Ω 34.6Ω

Fig. 17 IFOUT 50MHz example of impedance matching

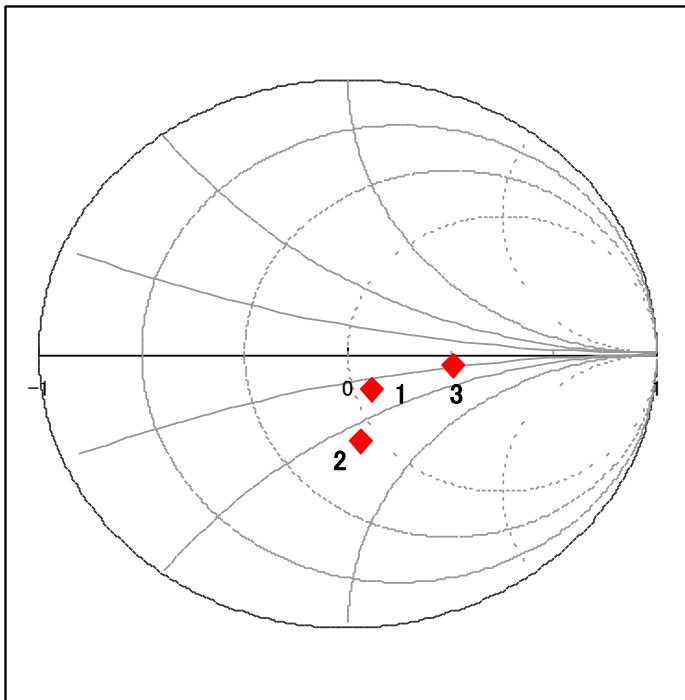

Frequency [MHz]	R1 [kΩ]	C2 [pF]	L2 [nH]	L3 [nH]
60	2.2	0.5	1000	1000

Start 10MHz, Stop 140MHz

Marker 1

60MHz: 52.7Ω -19.0Ω

Marker 2

54MHz: 43.4Ω -33.1Ω

Marker 3

70MHz: 100.7Ω -8.4Ω

Fig. 18 IFOUT 60MHz example of impedance matching

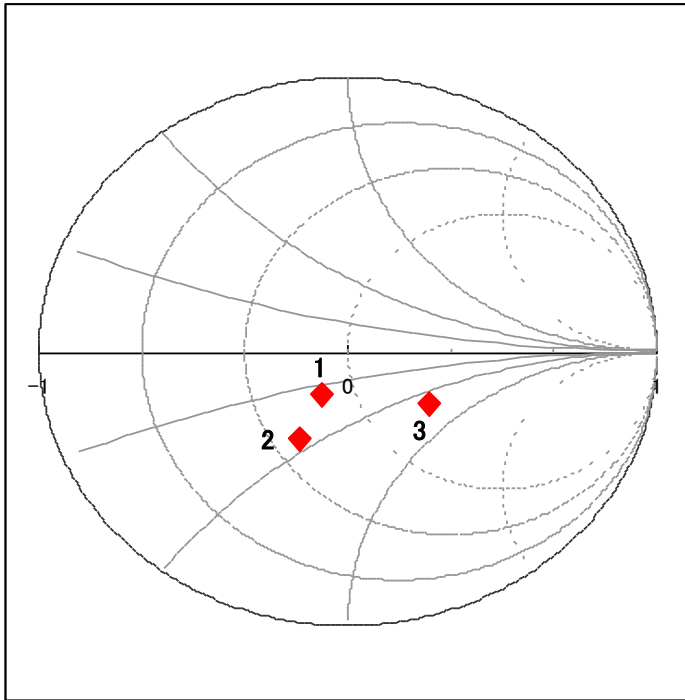

Frequency [MHz]	R1 [kΩ]	C2 [pF]	L2 [nH]	L3 [nH]
80	2.2	N/A	680	680

Start 10MHz, Stop 140MHz

Marker 1

80MHz: 38.5Ω -14.5Ω

Marker 2

75MHz: 31.2Ω -21.3Ω

Marker 3

95MHz: 78.7Ω -33.8Ω

Fig. 19 IFOUT 80MHz example of impedance matching

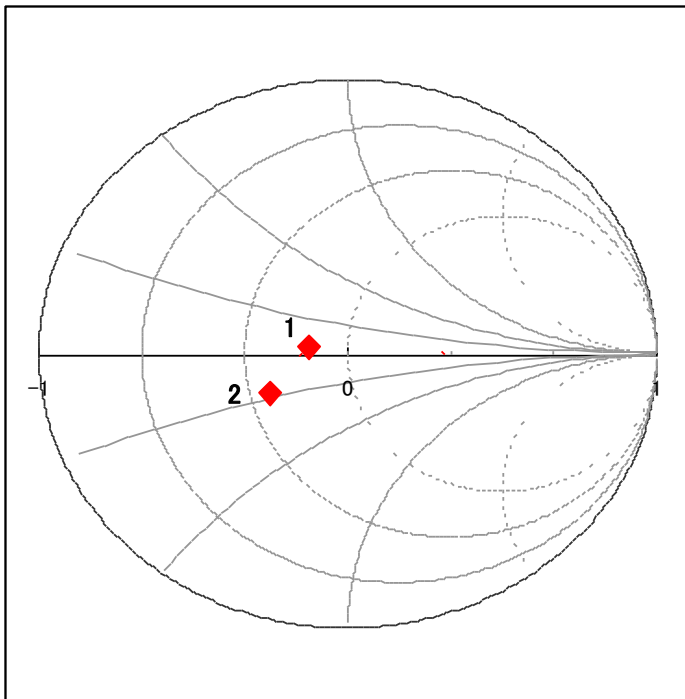

Frequency [MHz]	R1 [kΩ]	C2 [pF]	L2 [nH]	L3 [nH]
100	2.2	N/A	470	470

Start 10MHz, Stop 140MHz

Marker 1

100MHz: 38.9Ω 1.6Ω

Marker 2

90MHz: 26.9Ω -12.2Ω

Fig. 20 IFOUT 100MHz example of impedance matching

• LOINP/LOINN

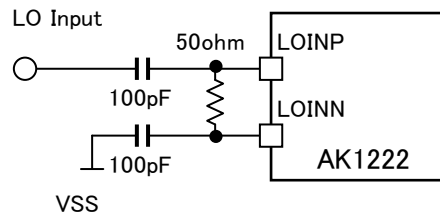
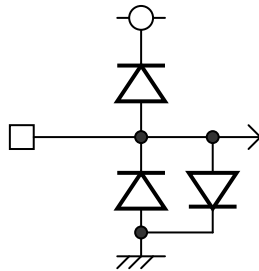
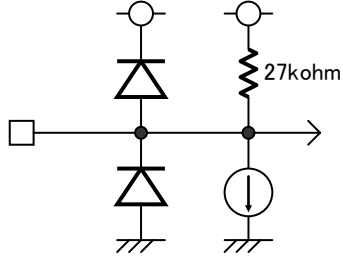
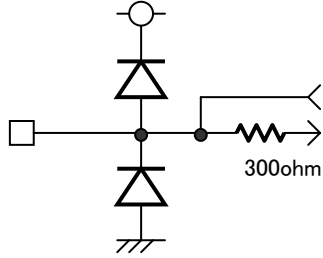
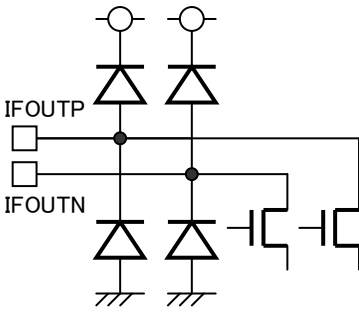

Fig. 21 LOINP/LOINN example of impedance matching

**11. IC Interface Schematic**

No.	Name	I/O	Function
1	RFIN	I	<b>RF input pin</b> 
3	LOINN	I	<b>LO input pins</b> 
4	LOINP	I	
9	BIAS	I/O	<b>Analog I/O pin</b> 
11	IFOUTN	O	<b>IF output pins</b> 
12	IFOUTP	O	



**12. Outer Dimensions**

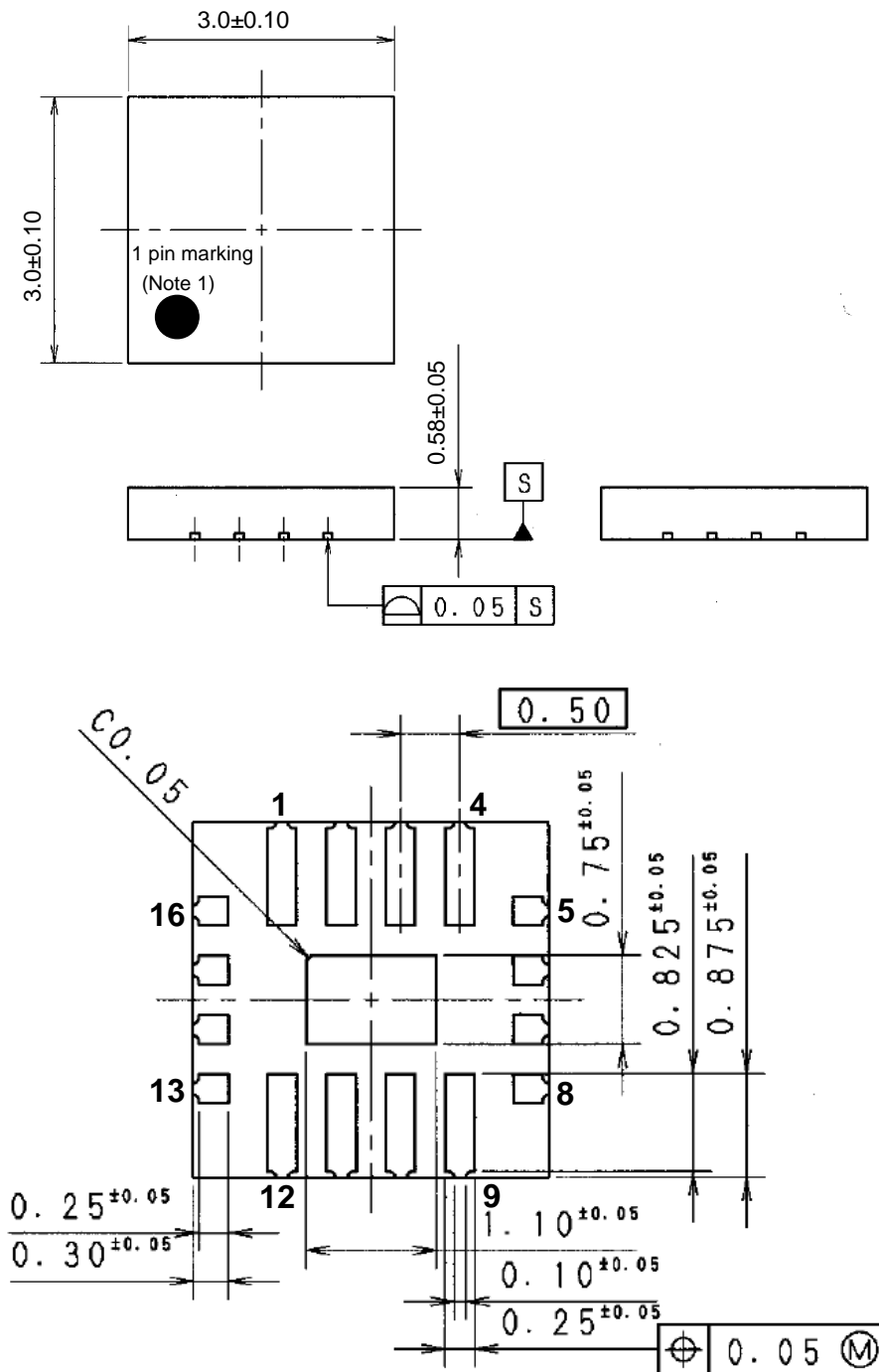
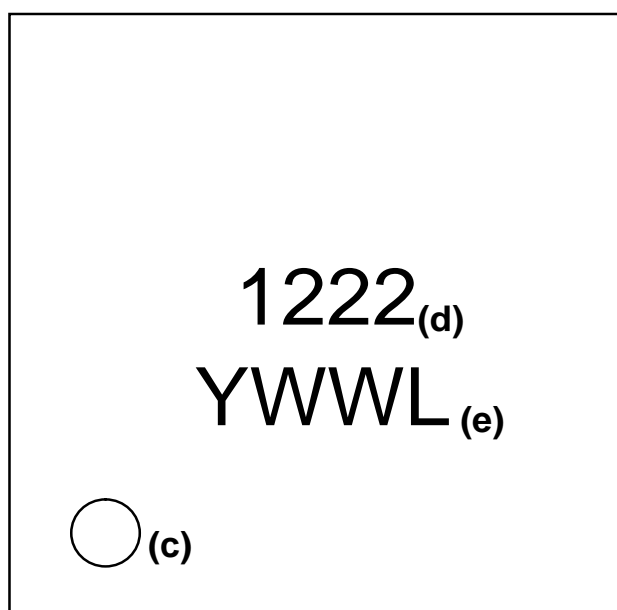

**Fig. 22 Outer Dimensions**

Note 1. 1 pin marking is only a reference for the 1 pin location on the top of package.

**13. Marking**

- (a) Style : QFN  
(b) Number of pins : 16  
(c) 1 pin marking: : ○  
(d) Product number : 1222  
(e) Date code : YWWL (4 digits)  
Y: Lower 1 digit of calendar year (Year 2011 → 1, 2012 → 2 ...)  
WW: Week  
Lot identification, given to each product lot which is made in a week  
→ LOT ID is given in alphabetical order (A, B, C...).

**Fig. 23 Marking**

## IMPORTANT NOTICE

0. Asahi Kasei Microdevices Corporation (“AKM”) reserves the right to make changes to the information contained in this document without notice. When you consider any use or application of AKM product stipulated in this document (“Product”), please make inquiries the sales office of AKM or authorized distributors as to current status of the Products.
1. All information included in this document are provided only to illustrate the operation and application examples of AKM Products. AKM neither makes warranties or representations with respect to the accuracy or completeness of the information contained in this document nor grants any license to any intellectual property rights or any other rights of AKM or any third party with respect to the information in this document. You are fully responsible for use of such information contained in this document in your product design or applications. **AKM ASSUMES NO LIABILITY FOR ANY LOSSES INCURRED BY YOU OR THIRD PARTIES ARISING FROM THE USE OF SUCH INFORMATION IN YOUR PRODUCT DESIGN OR APPLICATIONS.**
2. The Product is neither intended nor warranted for use in equipment or systems that require extraordinarily high levels of quality and/or reliability and/or a malfunction or failure of which may cause loss of human life, bodily injury, serious property damage or serious public impact, including but not limited to, equipment used in nuclear facilities, equipment used in the aerospace industry, medical equipment, equipment used for automobiles, trains, ships and other transportation, traffic signaling equipment, equipment used to control combustions or explosions, safety devices, elevators and escalators, devices related to electric power, and equipment used in finance-related fields. Do not use Product for the above use unless specifically agreed by AKM in writing.
3. Though AKM works continually to improve the Product’s quality and reliability, you are responsible for complying with safety standards and for providing adequate designs and safeguards for your hardware, software and systems which minimize risk and avoid situations in which a malfunction or failure of the Product could cause loss of human life, bodily injury or damage to property, including data loss or corruption.
4. Do not use or otherwise make available the Product or related technology or any information contained in this document for any military purposes, including without limitation, for the design, development, use, stockpiling or manufacturing of nuclear, chemical, or biological weapons or missile technology products (mass destruction weapons). When exporting the Products or related technology or any information contained in this document, you should comply with the applicable export control laws and regulations and follow the procedures required by such laws and regulations. The Products and related technology may not be used for or incorporated into any products or systems whose manufacture, use, or sale is prohibited under any applicable domestic or foreign laws or regulations.
5. Please contact AKM sales representative for details as to environmental matters such as the RoHS compatibility of the Product. Please use the Product in compliance with all applicable laws and regulations that regulate the inclusion or use of controlled substances, including without limitation, the EU RoHS Directive. AKM assumes no liability for damages or losses occurring as a result of noncompliance with applicable laws and regulations.
6. Resale of the Product with provisions different from the statement and/or technical features set forth in this document shall immediately void any warranty granted by AKM for the Product and shall not create or extend in any manner whatsoever, any liability of AKM.
7. This document may not be reproduced or duplicated, in any form, in whole or in part, without prior written consent of AKM.