

- 1. CONSTRUCTION Pink surface mount LEDs with reflector packaged featuring InGaN on SiC and phosphor technology.
- 2. USAGE Source of light for display unit.
- 3. DIMENSIONS See Figure.1
- 4. ABSOLUTE MAXIMUM RATINGS (Ta=25°C)

Power Dissipation	P D	66mW
Forward Current	I F	20mA
Peak Forward Current	I F P	100mA (Notes 1)
Reverse Voltage	V R	5V
Operating Temperature	Topr	-40°C ~ + 85°C
Storage Temperature	Tstg	-40°C ~ +100°C
		(Notes1 Duty 1/10 1kHz)	

5. ELECTRO—CHARACTERISTICS (Ta=25°C)

DISCRIPTION	SYMBOL	CONDITION	MIN.	TYP.	MAX.	UNITS
Forward Voltage	VF	IF=5mA * ¹	—	2.9	3.3	V
Reverse Current	IR	VR=5V	—	—	10	μ A
Luminous Intensity	IV	IF=5mA * ¹	9.0	22	56	mcd
Chromaticity Coordinates	x	IF=5mA * ¹	—	0.47	—	—
	y	IF=5mA * ¹	—	0.25	—	—

*¹ Pulse width :30msec.

6. LUMINOUS CLASSIFICATION (Ta=25°C, IF=5mA)

SYMBOL	LUMINOUS CLASSIFICATION RANGE
“M”	9.0 ~ 14 mcd
“N”	14 ~ 22 mcd
“P”	22 ~ 36 mcd
“Q”	36 ~ 56 mcd

If rank shift occur, we may ask for re-approval of new rank when necessary.

Measurement tolerance : ±10%

7. CHROMATICITY DIAGRAM

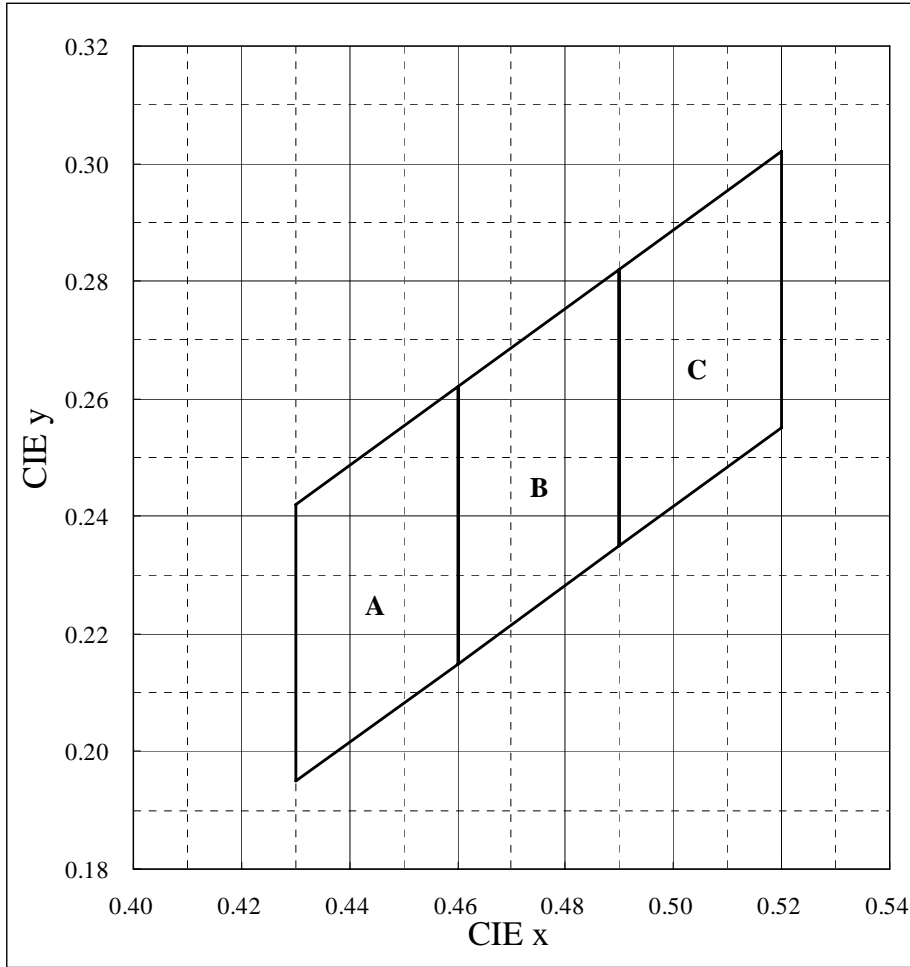

8. CHROMATICITY COORDIMATES (Ta=25°C, IF=5mA)

A		B		C	
x	y	x	y	x	y
0.430	0.242	0.460	0.262	0.490	0.282
0.430	0.195	0.460	0.215	0.490	0.235
0.460	0.215	0.490	0.235	0.520	0.255
0.460	0.262	0.490	0.282	0.520	0.302

Measurement tolerance : ±0.02

9. PRODUCT WEIGHT Product weight per piece, approx 0.0013gm.

【Figure 1】

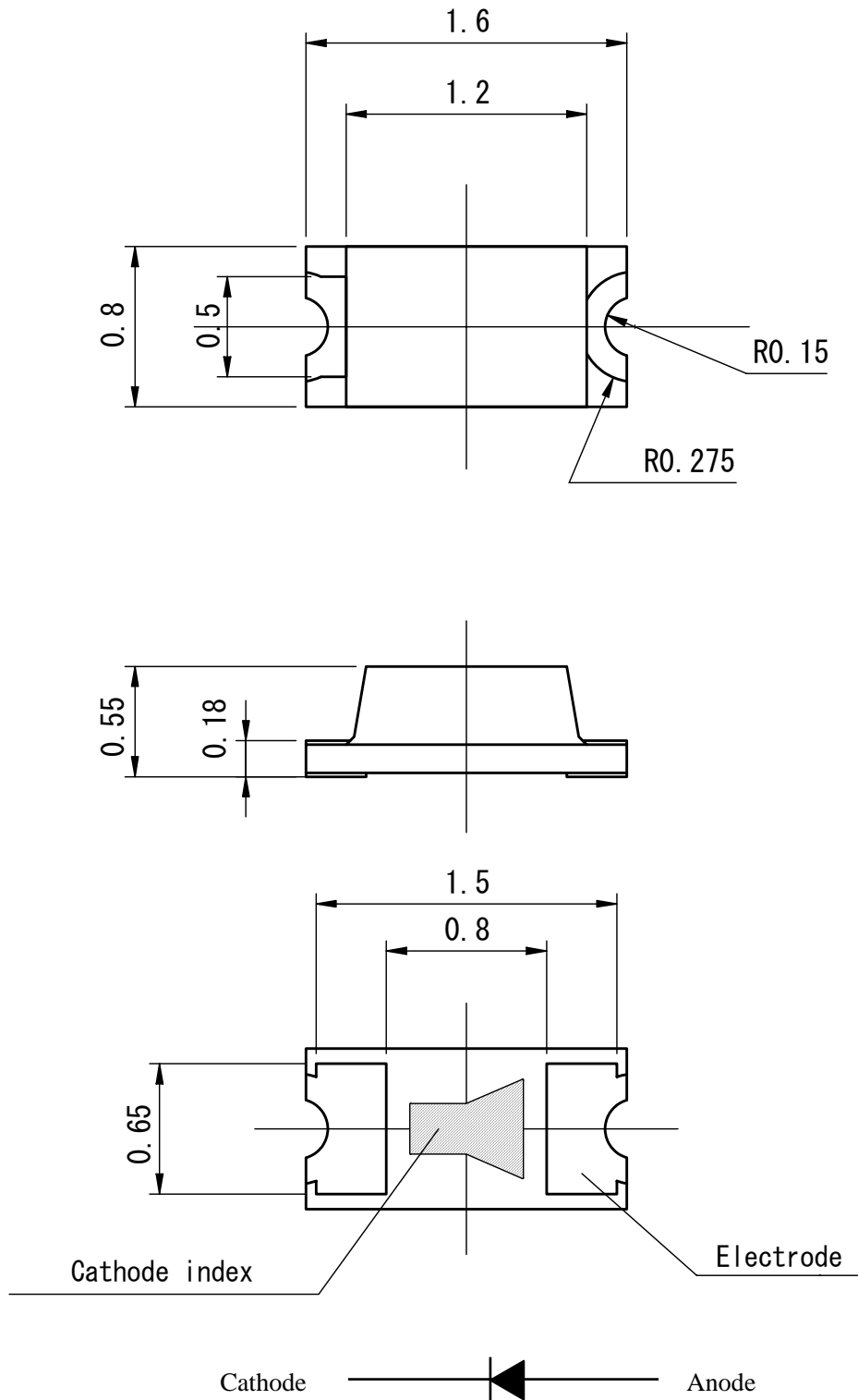

(Unit : mm)

(Note) Tolerance is within ± 0.1 mm unless otherwise specified.

【Taping : 1】

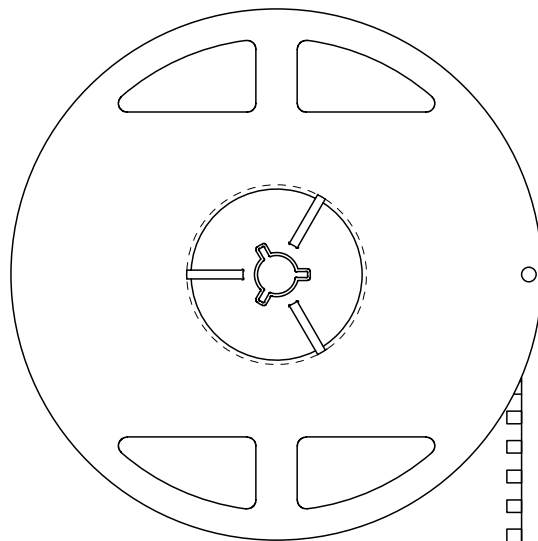
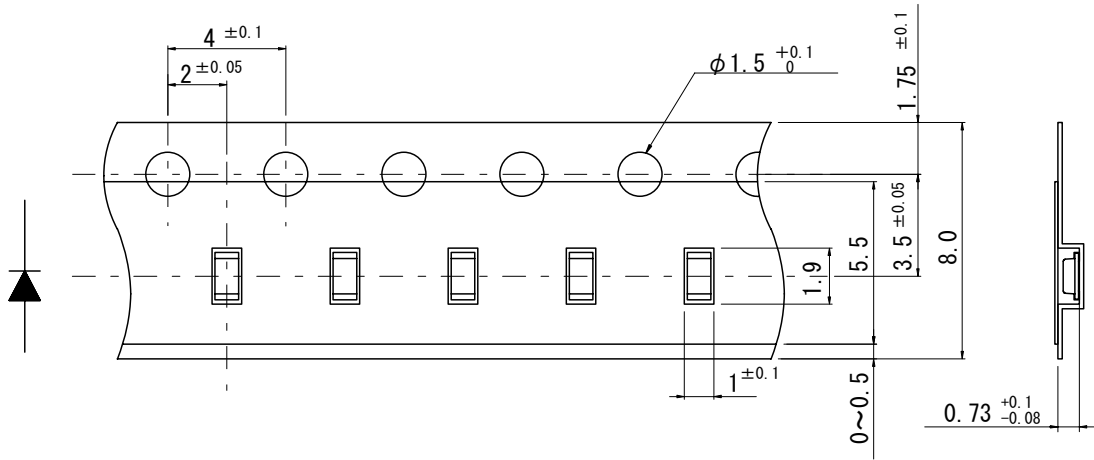

Packing quantity
3000pcs/reel

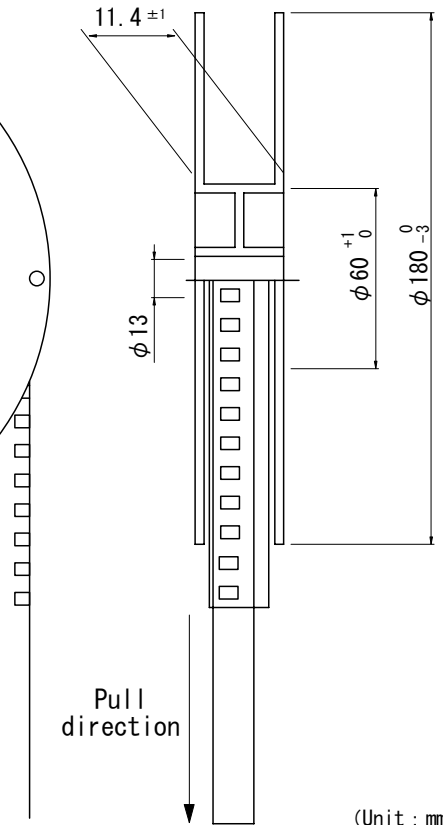

(Unit : mm)

(note) Tolerance is within ± 0.2 mm
unless otherwise specified

【STRUCTURE · MATERIAL】

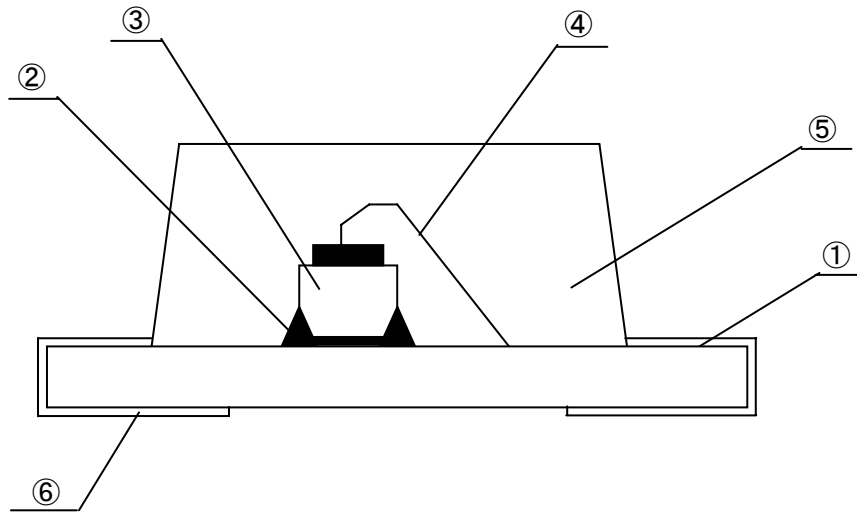

No.	APPELLATION	MATERIAL
1	Printed Wiring Board	BT Resin, Glass Fabric
2	Die Bond	Ag Paste
3	Chip	AlGaInP on GaAs
4	Bonding Wire	Gold
5	Resin	Epoxy Resin
6	Electrode	Bass plating : Cu , Nickel Top plating : Au

【PACKAGING REQUIREMENTS】

1. PACKING

- (1) 3,000pcs are taped in one reel.
- (2) One reel is packed in aluminum bag.
The size of aluminum bag is 240(a) × 250(b)mm.
The size up to zipper is 230(c)mm.
- (3) Aluminum bag is sealed by pressure for all directions.

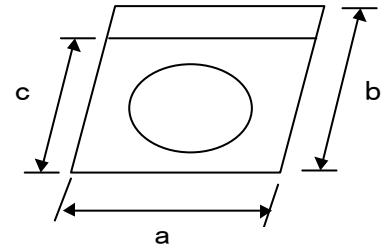

2. MARKING

The following information shall be described in the label on the aluminum bag.:
ROHM Type number, Packing quantity, Luminous intensity rank, and Lot number etc.

【FORMER LABEL SPECIFICATION】

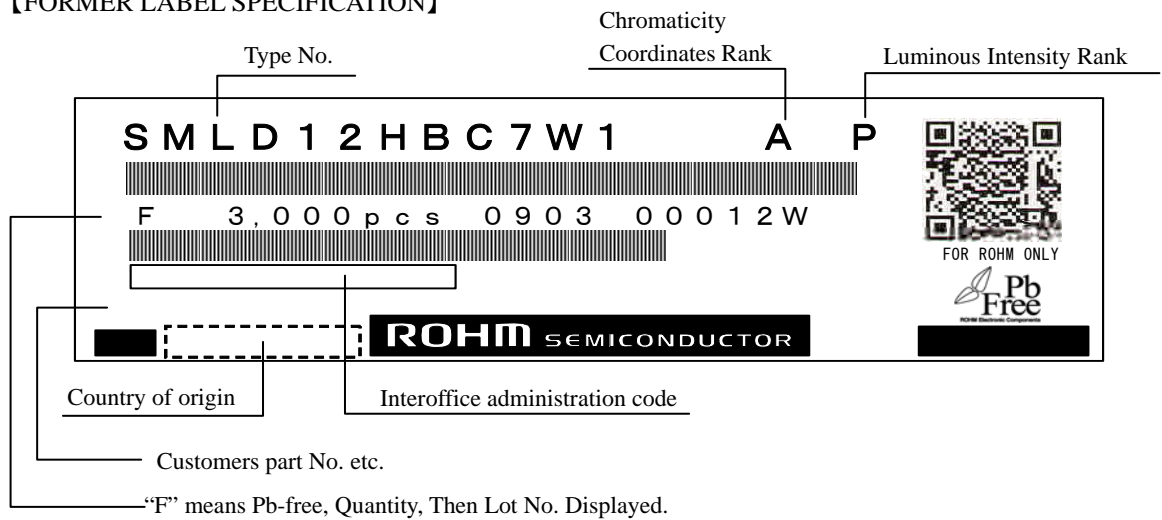

Note)  Indicates bar code expressed by code 39.

 indicates Pb-free Products.

【EXAMPLE OF LOT NO. MARKING】

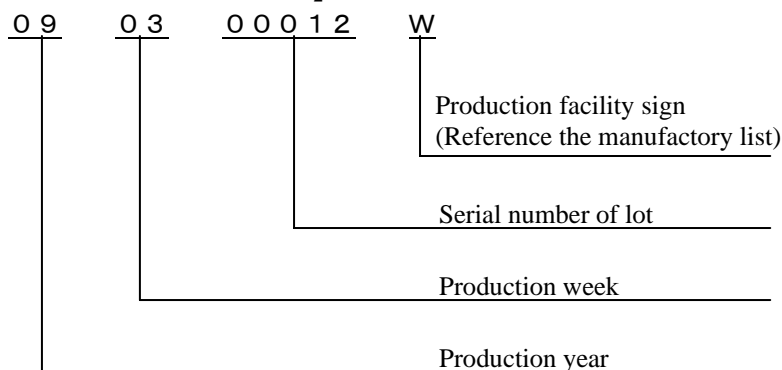

【ATTENTION POINTS IN HANDLING】

This product was developed as a surface mount LED especially suitable for reflow soldering. Please take care of following points when using this device.

1. DESIGNING OF PCB

As for a recommendable solder pattern, Please refer to Fig-1.
The size and direction of the pad pattern depend on the condition of the PCB, so, please investigate about the adjustment thoroughly before designing.
(This product is structured with rear electrode to be soldered; i.e., the electrode shape is not subject to the formation of solder fillet.)

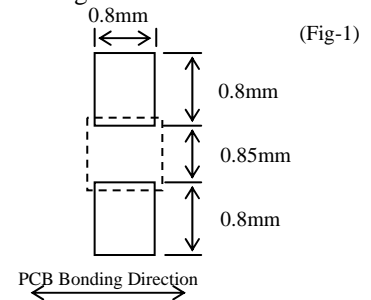

2. SOLDERING (Sn-Cu, Sn-Ag-Cu, Sn-Ag-Bi-Cu)

LED products do not contain reinforcement materials such as glass fillers. Therefore, thermal stress by soldering greatly influences its reliability. The temperature conditions for reflow soldering should therefore be set up according to the characteristic of this product. (See Fig-2)
Number of reflow process shall be max 2 times and these processes shall be performed in a row. Cooling process to normal temperature shall be required between the first and the second soldering process.

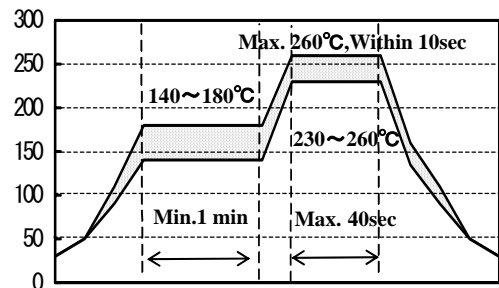

3. HANDLING AFTER MOUNTING (Fig.-3)

As shown in the drawing on the right, in case outside force of about 700g is given to the device, stress is concentrated to the jointed part between mold resin and substrate. Therefore there is a possibility to breath the device or PCB. Careful handling is needed as ROHM cannot guarantee the falling of the device by outside force after mounting.

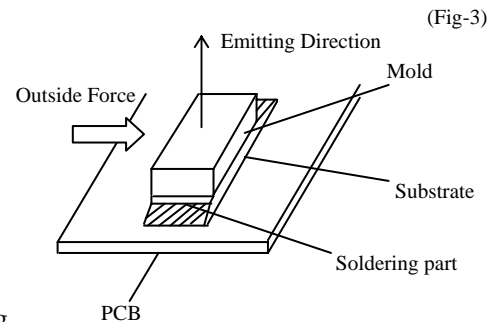

4. WASHING

Please note the following points when washing is required after soldering.

- 4-1) WASHING SOLVENT
Isopropyl alcohol or other alcohol solvent is recommendable.
- 4-2) TEMPERATURE
Below 30°C, immersion time ; within 3 minutes.
- 4-3) ULTRA SONIC WASHING
Below 15W/1 litter of solvent tub or less.
- 4-4) COOLING
Below 100°C within 3 minutes.

5. STORAGE

At reflow soldering, the reliability of this product is often influenced by moisture absorption; so that we apply the package with moisture proof for better condition for use. Please also note that,

- 5-1) Package : Not to be opened before using.
- 5-2) After unpackaging : LEDs to be kept in our moisture proof package with some desiccant (SILICA GEL). LEDs to be baked in case the SILICA GEL indicator its color from either blue to clear or green to pink.
- 5-3) Please use LEDs within 168 hours after the package is opened. (Condition at 30°C, max.70%Rh.)
In case they are not used within 168 hours, please put them back into the package.
- 5-4) BAKING (=Moisture Removal)
Please conduct baking under “reel condition” at 60°C, 12~24 hours (max.20%Rh) after unpackaging. Please be careful not to give any stress to the reel & the embossed tape while baking, as they are susceptible to be deformed during the baking.