

## Adjustable shunt regulator

# TL432A3/N3/M3/K3

### Description

The TL432 is a three terminal adjustable shunt regulator with thermal stability guaranteed over temperature. The output voltage can be adjusted to any value from 1.24V ( $V_{REF}$ ) to 18V with two external resistors. The TL432 has a typical dynamic output impedance of  $0.2\ \Omega$ . Active output circuitry provides a very sharp turn on characteristic, making the TL432 an excellent replacement for zener diodes. The TL432 shunt regulator is available with two voltage tolerances (0.5%, and 1%), and four package options (TO-92, SOT-23, SOT-89 and TO-92L). This allows the designer the opportunity to select the optimum combination of cost and performance for their application.

### Features

- ◆ Low voltage operation (down to 1.24V)
- ◆ Fast turn on response
- ◆ Low dynamic output impedance  $0.2\ \Omega$  typ.
- ◆ Trimmed bandgap design :  $\pm 0.5\%$
- ◆ Sink current capability : 100mA
- ◆ Available in TO-92, SOT-23, SOT-89, and TO-92L packages

### Applications

- ◆ Linear Regulators
- ◆ Adjustable Supplies
- ◆ Switching Power Supplies
- ◆ Battery Operated Computers
- ◆ Instrumentation
- ◆ Computer Disk Drives

### Typical Application Circuit (Note 1,2)

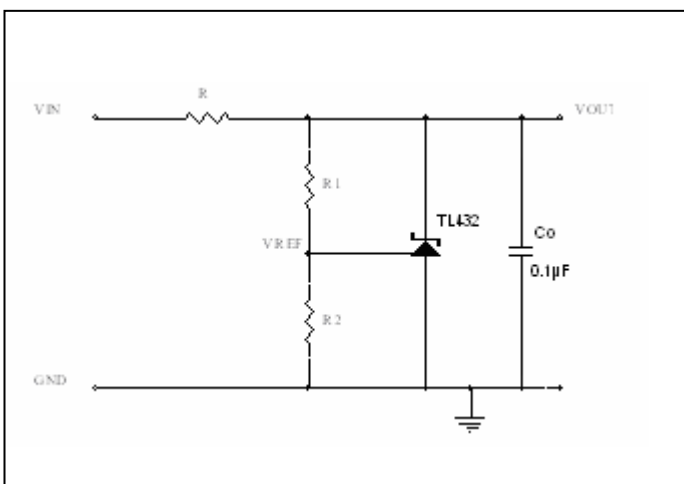

#### Notes:

- 1) Set  $V_{OUT}$  according to the following equation:  

$$V_{OUT} = V_{REF}(1 + R1/R2) + I_{REF}R1$$
- 2) Choose the value for R as follows:
  - The maximum limit for R should be such that the cathode current,  $I_z$ , is greater than the minimum operating current ( $80\ \mu A$ ) at  $V_{IN(MIN)}$ .
  - The minimum limit for R should be as such that  $I_z$  does not exceed 100mA under all load conditions, and the instantaneous turn-on value for  $I_z$  does not exceed 150mA. Both of the following conditions must be met:
    - $R_{min} \geq V_{IN(max)} / 150mA$  (to limit instantaneous turn-on  $I_z$ )
    - $R_{min} \geq \frac{V_{IN(max)} - V_{OUT}}{I_{OUT(min)} + 100mA}$  (to limit  $I_z$  under normal operating conditions)



**Absolute Maximum Ratings**

Parameter	Symbol	Maximum	Units
Cathode Voltage	$V_Z$	18	V
Continuous Cathode Current	$I_Z$	100	mA
Reference Input Current	$I_{REF}$	3	mA
Power Dissipation at $T_A=25^\circ\text{C}$			
SOT-23	$P_D$	0.18	W
SOT-89		0.4	
TO-92		0.5	
TO-92L		0.72	
Thermal Resistance			
SOT-23	$\theta_{JA}$	556	$^\circ\text{C}/\text{W}$
SOT-89		250	
TO-92		200	
TO-92L		139	
Operating Ambient Temperature Range	$T_A$	-40 to +85	$^\circ\text{C}$
Operating Junction Temperature Range	$T_J$	-40 to +125	$^\circ\text{C}$
Storage Temperature Range	$T_{stg}$	-65 to +150	$^\circ\text{C}$

**Electrical Characteristics**

Unless otherwise specified,  $T_A=25^\circ\text{C}$ . Values in bold apply over full operating ambient temperature range.

Parameter	Symbol	Condition	TL432 A-rank( $\pm 0.5\%$ )			TL432 B-rank( $\pm 1\%$ )			Unit
			Min	Typ	Max	Min	Typ	Max	
Reference Voltage	$V_{REF}$	$V_Z=V_{REF}, I_Z=10\text{mA}$ (Note 1)	1.234	1.240	1.246	1.228	1.240	1.252	V
$V_{REF}$ Temperature Deviation	$V_{DEV}$	$V_Z=V_{REF}, I_Z=10\text{mA}, T_A=-40\sim 105^\circ\text{C}$ (Note 1)	-	10	20	-	10	20	mV
Ratio of Change in $V_{REF}$ to change in $V_Z$	$\frac{\Delta V_{REF}}{\Delta V_Z}$	$I_Z=10\text{mA}, \Delta V_Z=18\text{V to } V_{REF}$	-	-1	-2.0	-	-1	-2.0	mV/V
Reference Input Current	$I_{REF}$	$R1=10\text{k}\Omega, R2=\infty, I_Z=10\text{mA}$ (Note 2)	-	0.25	0.5	-	0.25	0.5	$\mu\text{A}$
$I_{REF}$ Temperature Deviation	$I_{REF(DEV)}$	$R1=10\text{k}\Omega, R2=\infty, I_Z=10\text{mA}$ (Note 2)	-	0.05	0.3	-	0.05	0.3	$\mu\text{A}$
Off-state Cathode Current	$I_{Z(OFF)}$	$V_{REF}=0\text{V}, V_Z=18\text{V}$ (Note 3)	-	0.04	0.5	-	0.04	0.5	$\mu\text{A}$
Dynamic Output Impedance	$r_z$	$f < 1\text{kHz}, V_Z=V_{REF}, I_Z=1\text{mA to } 100\text{mA}$ (Note 1)	-	0.2	0.4	-	0.2	0.4	$\Omega$
Minimum Operating Current	$I_{Z(MIN)}$	$V_Z=V_{REF}$ (Note 1)	-	60	80	-	60	80	$\mu\text{A}$

**Notes:**

- (1) See Test Circuit 1.
- (2) See Test Circuit 2.
- (3) See Test Circuit 3.

**Test Circuits**

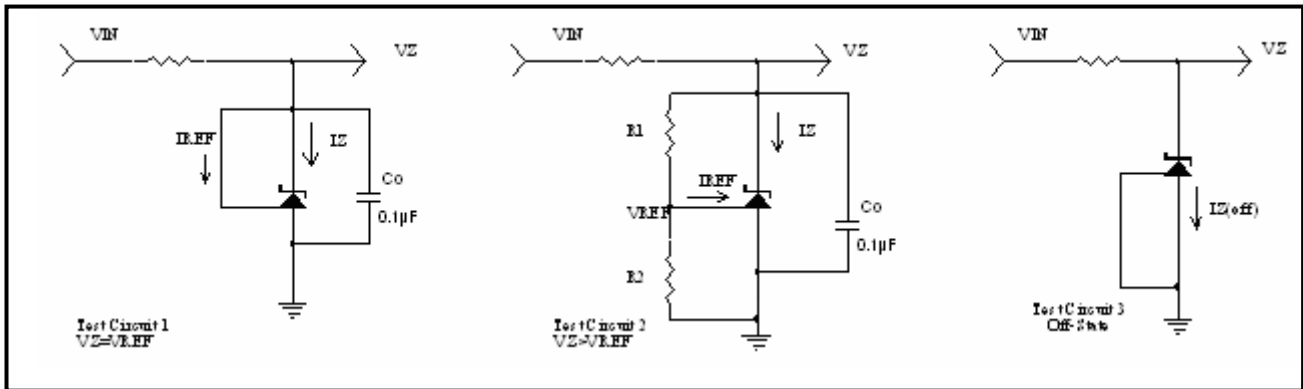

**Pin Configurations**

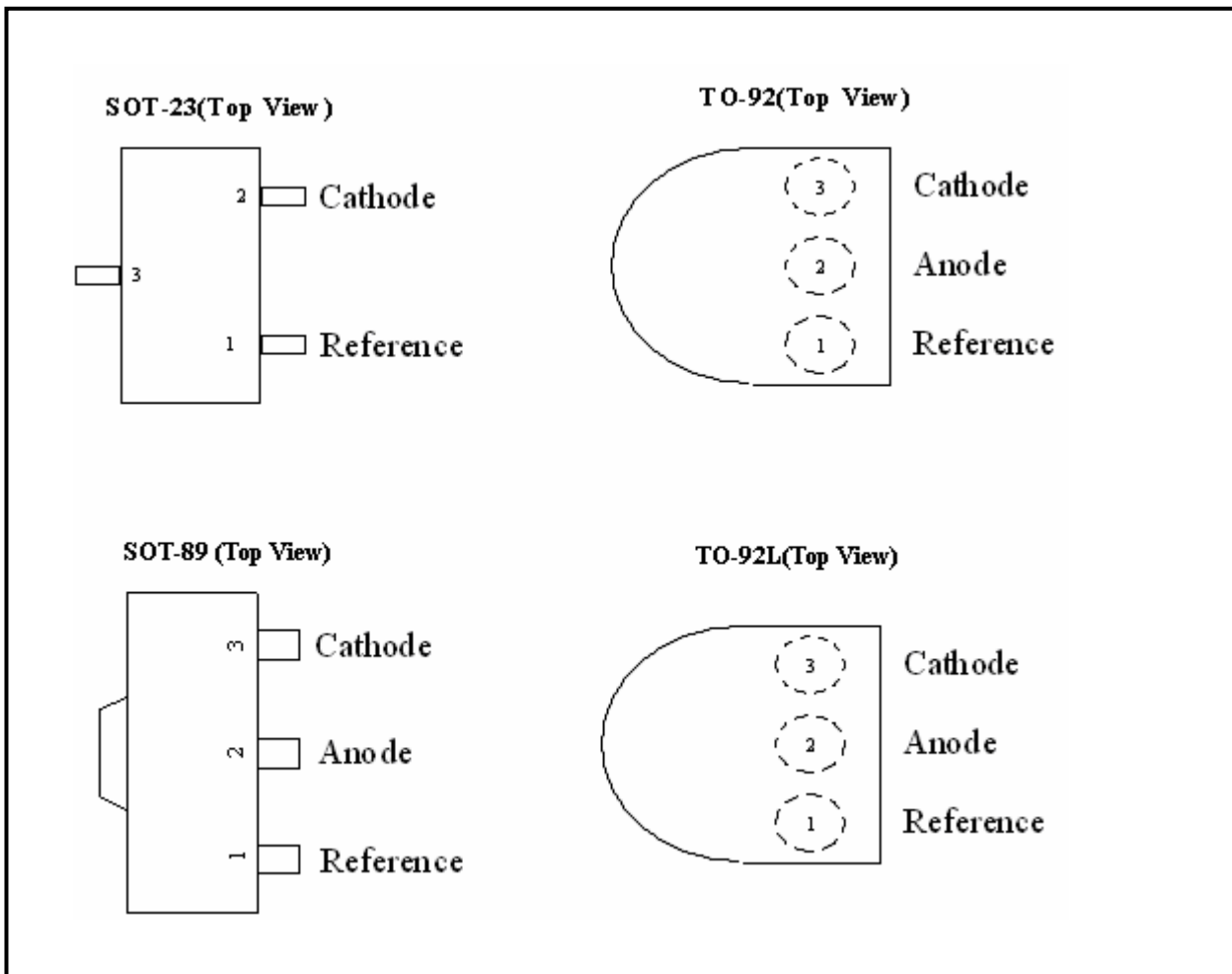

**Block Diagram**

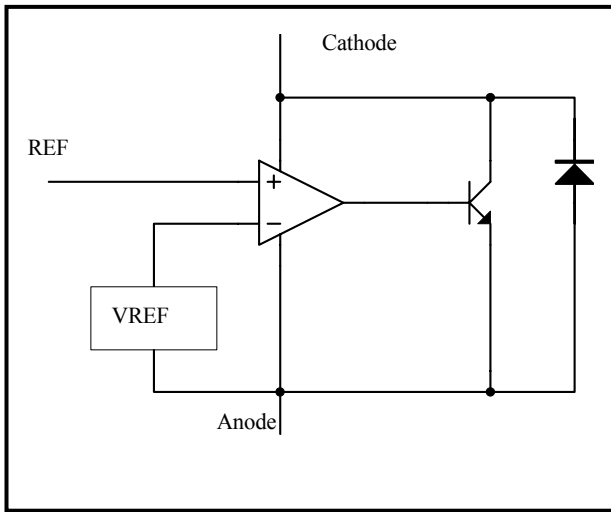

**Symbol**

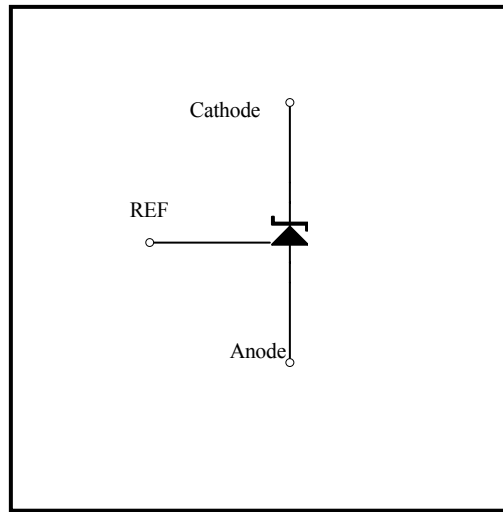

**Ordering Information**

Device	Package	Rank	Tolerance	Shipping
TL432A3-A-TB-G	TO-92 (Pb-free lead plating and halogen-free package)	A	±0.5%	2000 pcs / Tape & Box
TL432A3-B-TB-G		B	±1%	
TL432A3-A-BK-G		A	±0.5%	1000 pcs/ bag, 10 bags/box, 10boxes/carton
TL432A3-B-BK-G		B	±1%	
TL432K3-A-TB-G	TO-92L (Pb-free lead plating and halogen-free package)	A	±0.5%	2000 pcs / Tape & Box
TL432K3-B-TB-G		B	±1%	
TL432K3-A-BK-G		A	±0.5%	500 pcs/ bag, 10 bags/box, 10boxes/carton
TL432K3-B-BK-G		B	±1%	
TL432N3-A-T1-G	SOT-23 (Pb-free lead plating and halogen-free package)	A	±0.5%	3000 pcs / Tape & Reel
TL432N3-B-T1-G		B	±1%	
TL432M3-A-T1-G	SOT-89 (Pb-free lead plating and halogen-free package)	A	±0.5%	1000 pcs / Tape & Reel
TL432M3-B-T1-G		B	±1%	

**Typical Characteristics**

Cathode Current vs Cathode Voltage

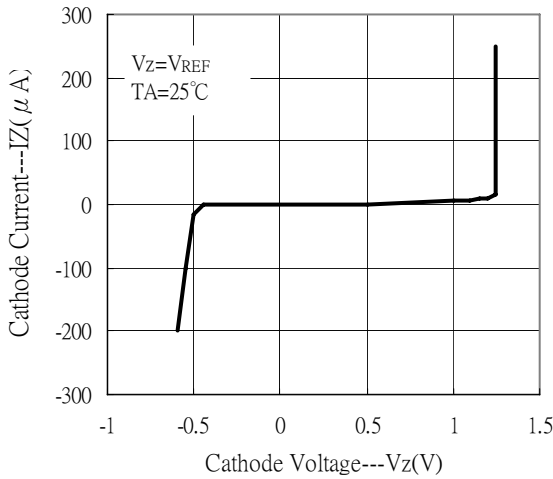

Cathode Current vs Cathode Voltage

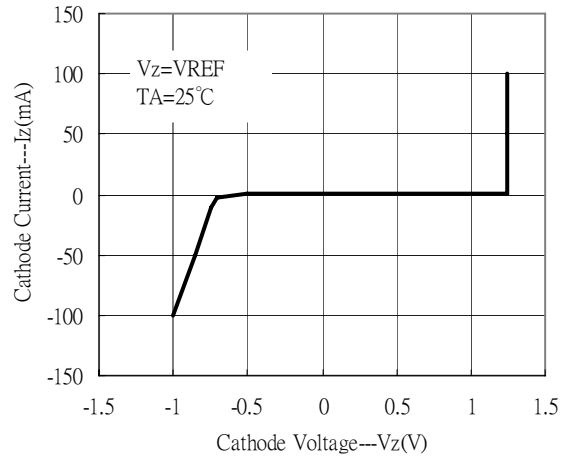

Reference Voltage vs Junction Temperature

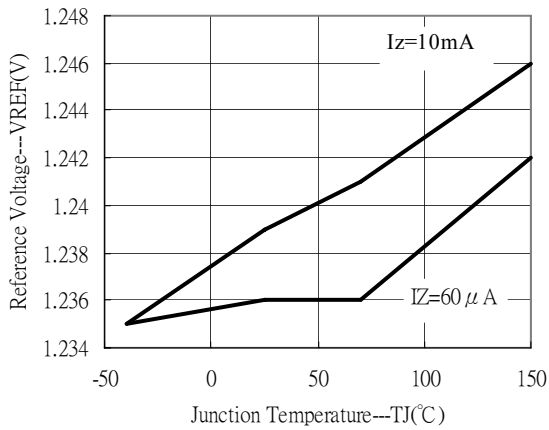

Reference Input Current vs Junction Temperature

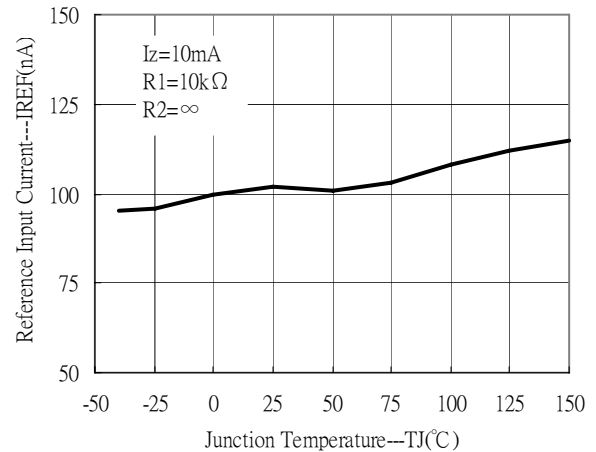

Ratio of Delta Reference Voltage to Delta Cathode Voltage vs Junction Temperature

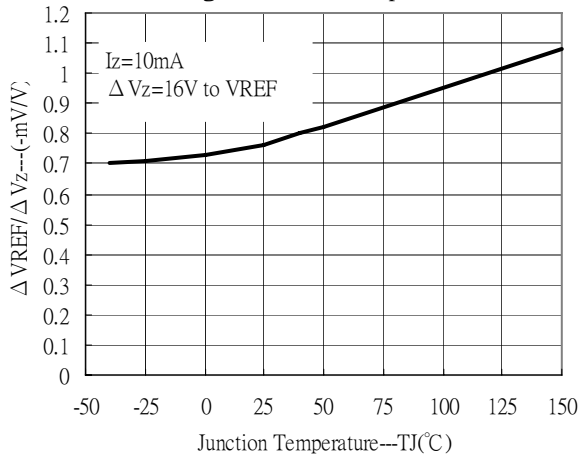

Off-State Cathode Current vs Junction Temperature

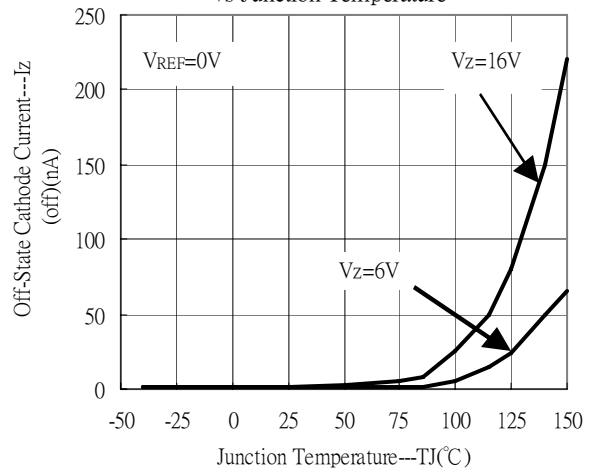

**Typical Characteristics (Cont.)**

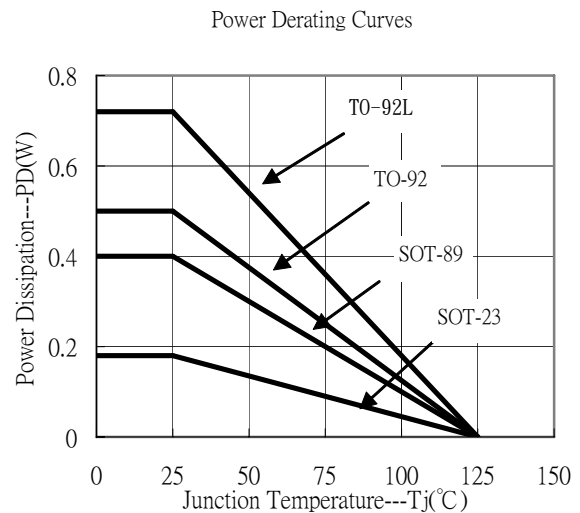
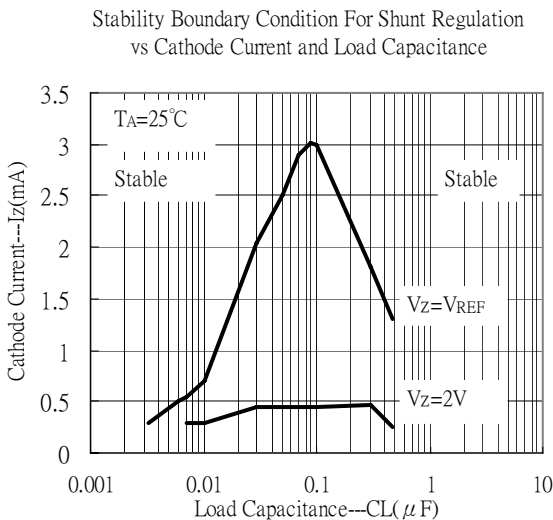
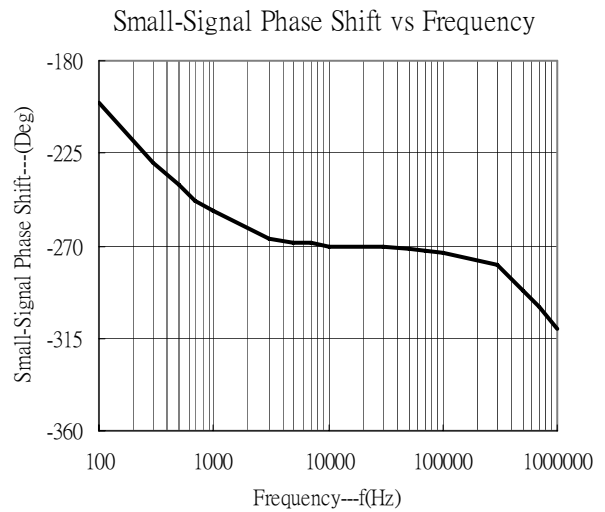
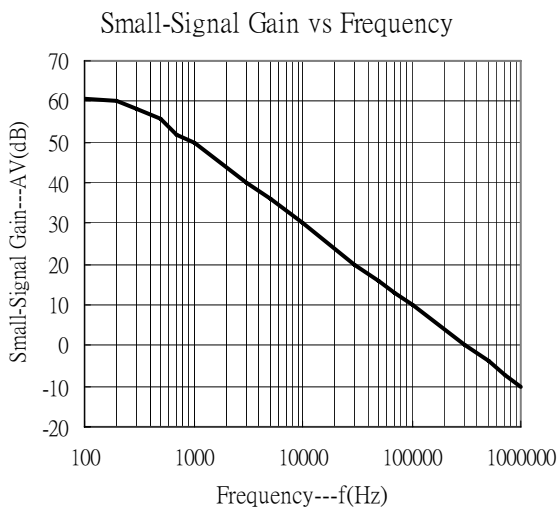
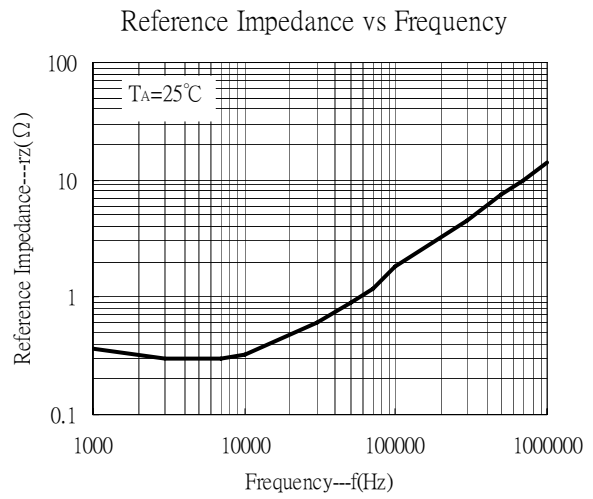
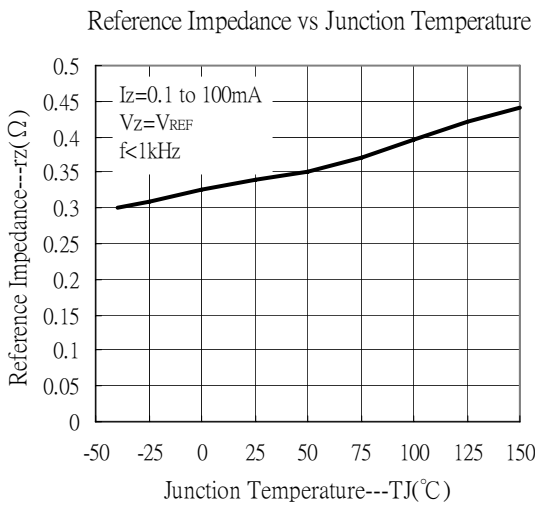

**Test Circuit-Small-Signal Gain and Phase**

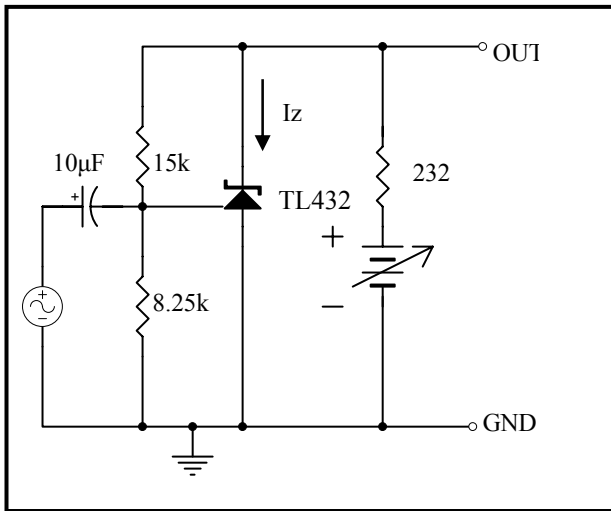

**Test Circuit-Stability**

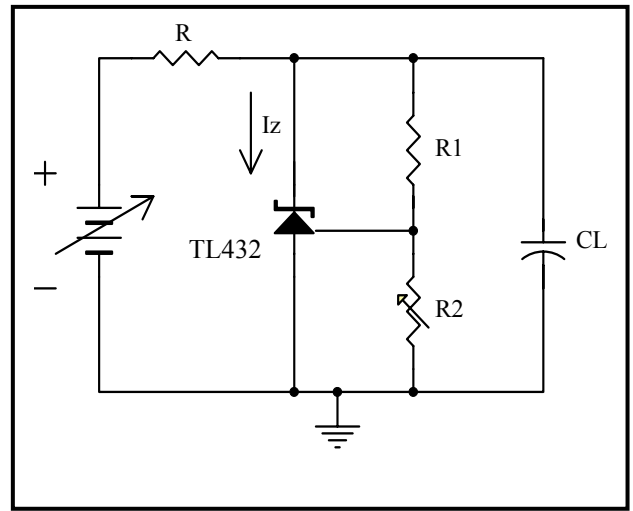

**Applications Information - Stability**

**Selection of load capacitance when using TL432 as a shunt regulator**

When the TL432 is used as a shunt regulator, two options for selection of  $C_L$ (see diagram on page 6) are recommended for optimal stability:

- 1) No load capacitance across the device, decouple at the load.
- 2) Large capacitance across the device, optimal decoupling at the load.

The reason for this is that TL432 exhibits instability with capacitances in the range of 10nF to 1µF (approx.) at light cathode currents(up to 3mA typical). The device is less stable the lower the cathode voltage has been set for. Therefore while the device will be perfectly stable operating at a cathode current of (say) 10mA with a 0.1µF capacitor across it, it will oscillate transiently during start-up as the cathode current passes through the instability region. Selecting a very low (or preferably, no) capacitance, or alternatively a high capacitance(such as 10µF) will avoid this issue altogether. Since the user will probably wish to have local decoupling at the load anyway, the most cost effective method is to use no capacitance at all directly across the device. PCB trace/via resistance and inductance prevent the local load decoupling from causing the oscillation during the transient start-up phase.

Note : if the TL432 is located right at the load, so the load decoupling capacitor is directly across it, then this capacitor will have to be  $\leq 1\text{nF}$  or  $\geq 10\mu\text{F}$ .

**TO-92 Taping Outline**

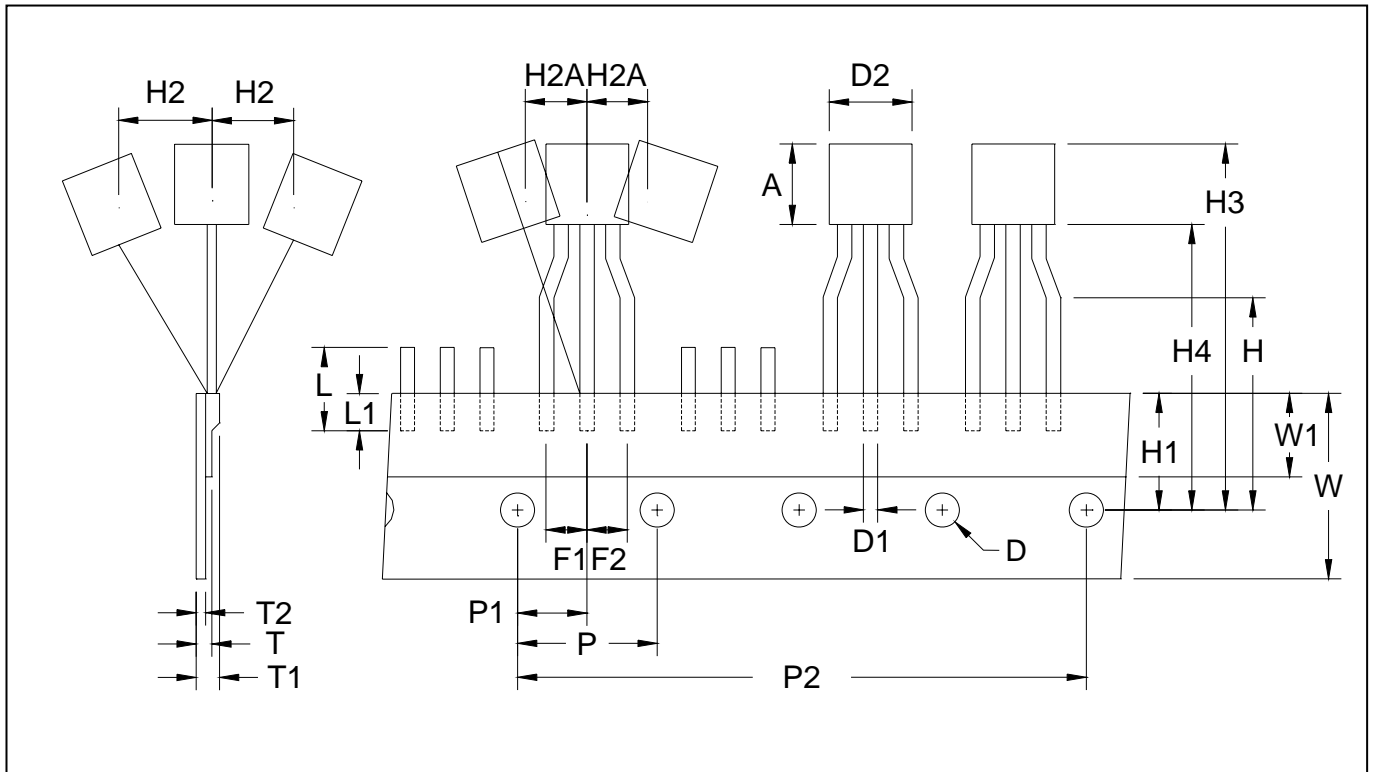

DIM	Item	Millimeters	
		Min.	Max.
A	Component body height	4.33	4.83
D	Tape Feed Diameter	3.80	4.20
D1	Lead Diameter	0.36	0.53
D2	Component Body Diameter	4.33	4.83
F1,F2	Component Lead Pitch	2.40	2.90
F1,F2	F1-F2	-	±0.3
H	Height Of Seating Plane	15.50	16.50
H1	Feed Hole Location	8.50	9.50
H2	Front To Rear Deflection	-	1
H2A	Deflection Left Or Right	-	1
H3	Component Height	-	27
H4	Feed Hole To Bottom Of Component	-	21
L	Lead Length After Component Removal	-	11
L1	Lead Wire Enclosure	2.50	-
P	Feed Hole Pitch	12.50	12.90
P1	Center Of Seating Plane Location	5.95	6.75
P2	4 Feed Hole Pitch	50.30	51.30
T	Over All Tape Thickness	-	0.55
T1	Total Taped Package Thickness	-	1.42
T2	Carrier Tape Thickness	0.36	0.68
W	Tape Width	17.50	19.00
W1	Adhesive Tape Width	5.00	7.00
-	20 pcs Pitch	253	255





**SOT-89 Reel Dimension**

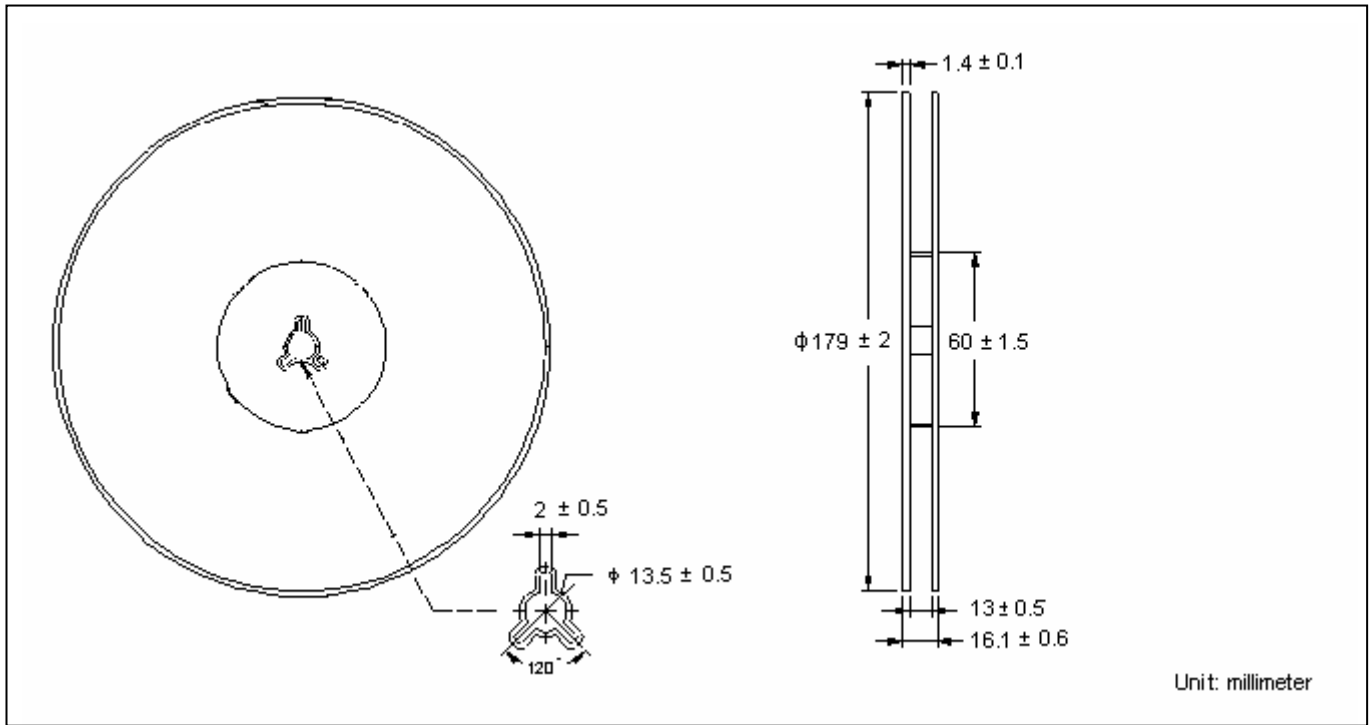

**SOT-89 Carrier Tape Dimension**

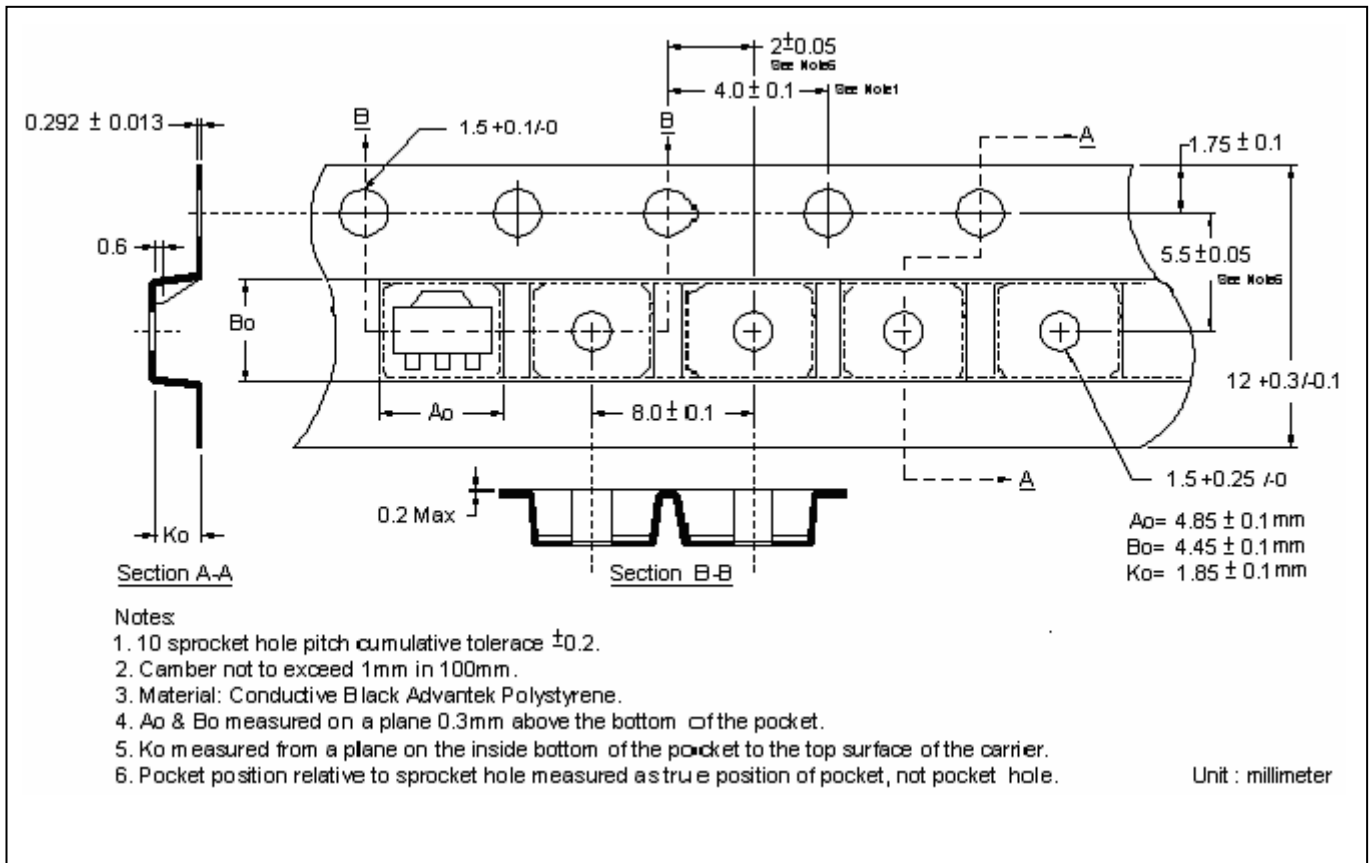

**TO-92L Taping Outline**

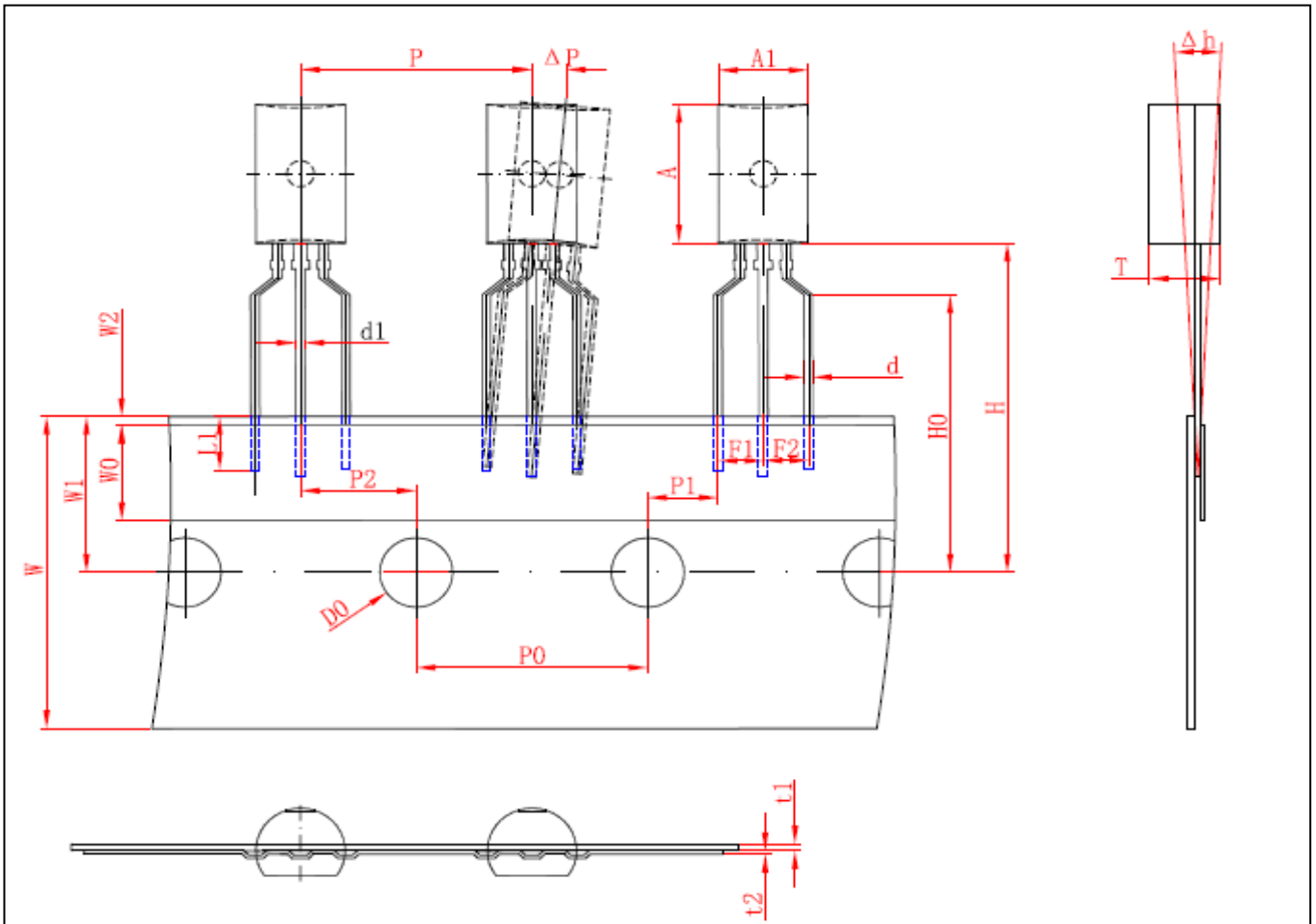

DIM	Item	Millimeters	
		Min.	Max.
A1	Component body width	4.70	5.10
A	Component body height	7.80	8.20
T	Component body thickness	3.70	4.10
d	Lead wire diameter	0.40	0.50
d1	Lead wire diameter 1	0.62	0.78
P	Pitch of component	12.40	13.00
P0	Feed hole pitch	12.50	12.90
P2	Hole center to component center	6.05	6.65
F1, F2	Lead to lead distance	2.20	2.80
Δh	Component alignment, F-R	-1.00	1.00
W	Tape width	17.50	19.00
W0	Hole down tape width	5.50	6.50
W1	Hole position	8.50	9.50
W2	Hole down tape position	-	1.00
H	Height of component from tape center	19.00	21.00
H0	Lead wire clinch height	15.50	16.50
L1	Lead wire (tape portion)	2.50	-
D0	Feed hole diameter	3.80	4.20
t1	Taped lead thickness	0.35	0.45
t2	Carrier tape thickness	0.15	0.25
P1	Position of hole	3.55	4.15
ΔP	Component alignment	-1.00	1.00

**TO-92 Dimension**

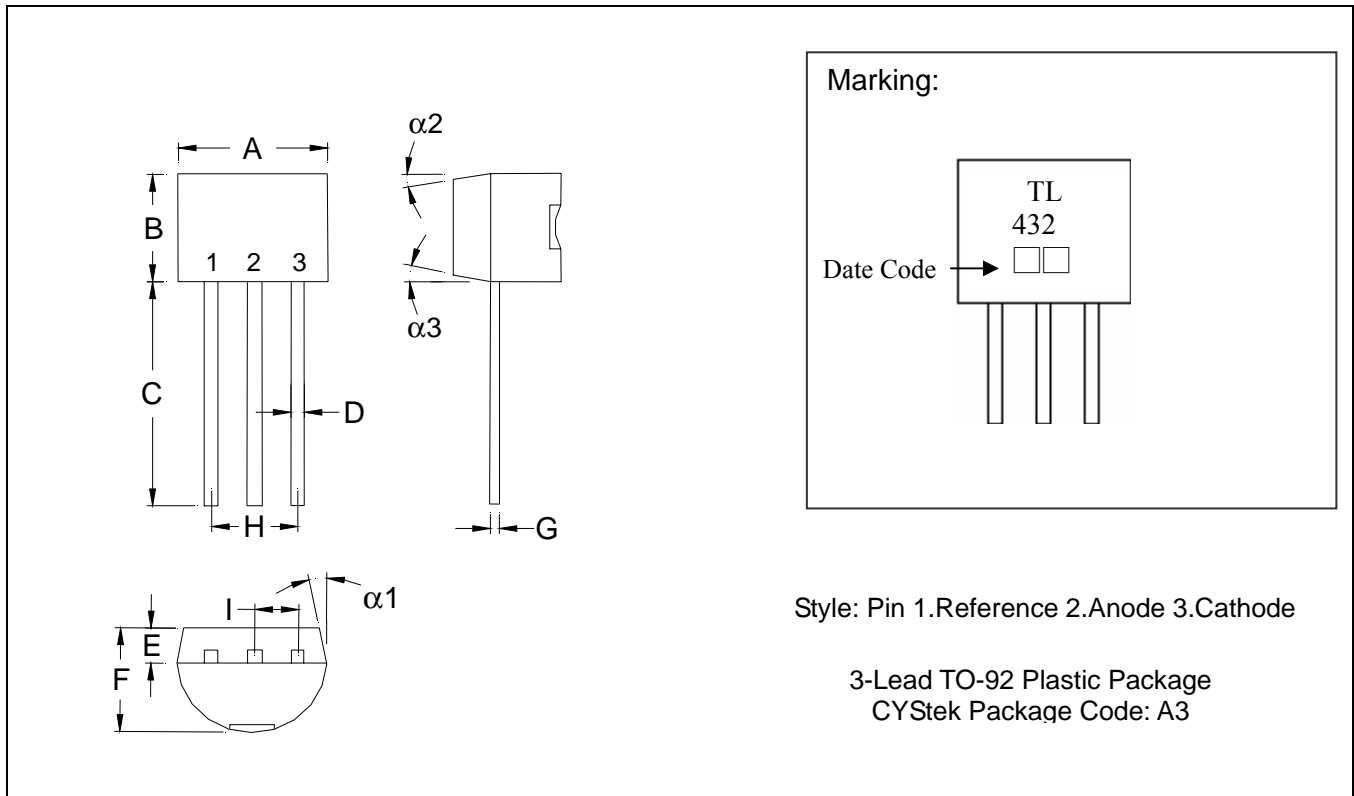

\*: Typical

DIM	Inches		Millimeters		DIM	Inches		Millimeters	
	Min.	Max.	Min.	Max.		Min.	Max.	Min.	Max.
A	0.1704	0.1902	4.33	4.83	G	0.0142	0.0220	0.36	0.56
B	0.1704	0.1902	4.33	4.83	H	-	*0.1000	-	*2.54
C	0.5000	-	12.70	-	I	-	*0.0500	-	*1.27
D	0.0142	0.0220	0.36	0.56	$\alpha 1$	-	*5°	-	*5°
E	-	*0.0500	-	*1.27	$\alpha 2$	-	*2°	-	*2°
F	0.1323	0.1480	3.36	3.76	$\alpha 3$	-	*2°	-	*2°

Notes: 1.Controlling dimension: millimeters.

2.Maximum lead thickness includes lead finish thickness, and minimum lead thickness is the minimum thickness of base material.

3.If there is any question with packing specification or packing method, please contact your local CYStek sales office.

**Material:**

- Lead: Pure tin plated.
- Mold Compound: Epoxy resin family, flammability solid burning class: UL94V-0.

**SOT-23 Dimension**

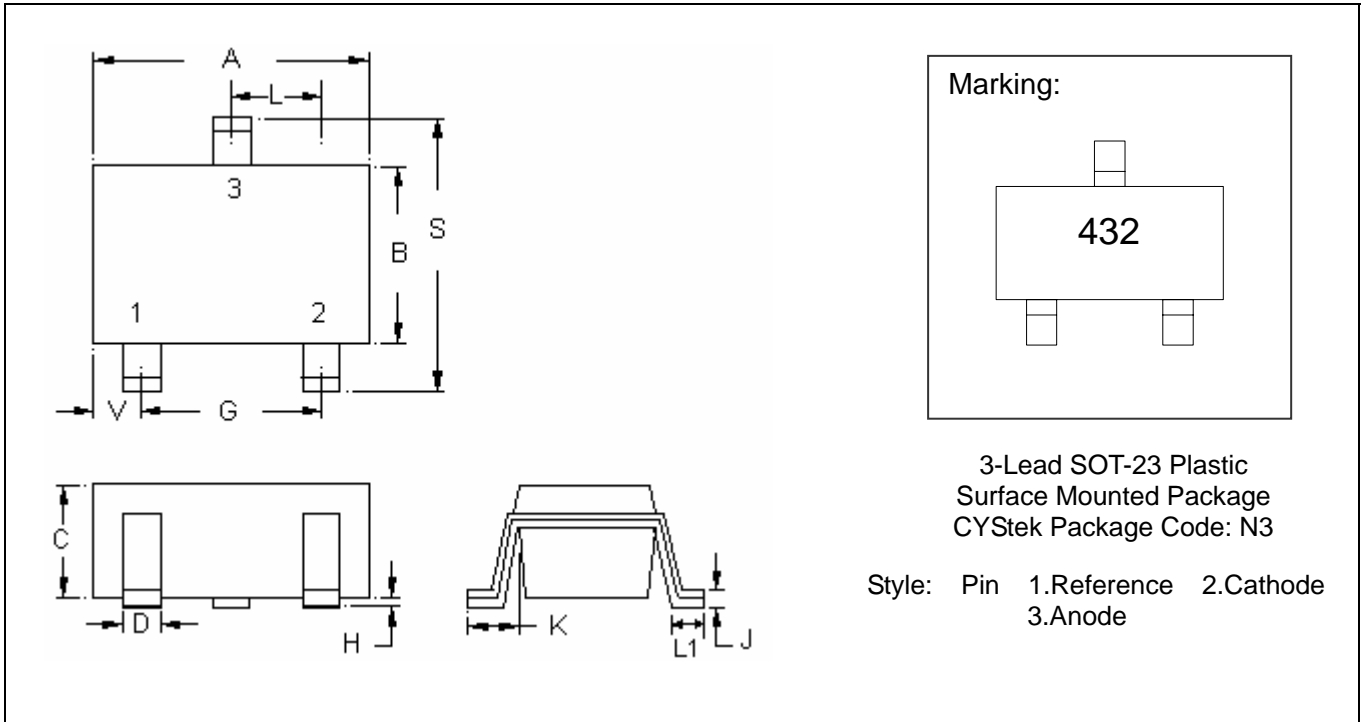

\*: Typical

DIM	Inches		Millimeters		DIM	Inches		Millimeters	
	Min.	Max.	Min.	Max.		Min.	Max.	Min.	Max.
A	0.1102	0.1204	2.80	3.04	J	0.0032	0.0079	0.08	0.20
B	0.0472	0.0669	1.20	1.70	K	0.0118	0.0266	0.30	0.67
C	0.0335	0.0512	0.89	1.30	L	0.0335	0.0453	0.85	1.15
D	0.0118	0.0197	0.30	0.50	S	0.0830	0.1161	2.10	2.95
G	0.0669	0.0910	1.70	2.30	V	0.0098	0.0256	0.25	0.65
H	0.0000	0.0040	0.00	0.10	L1	0.0118	0.0197	0.30	0.50

Notes: 1.Controlling dimension: millimeters.  
 2.Maximum lead thickness includes lead finish thickness, and minimum lead thickness is the minimum thickness of base material.  
 3.If there is any question with packing specification or packing method, please contact your local CYCtek sales office.

**Material:**

- Lead: Pure tin plated.
- Mold Compound: Epoxy resin family, flammability solid burning class: UL94V-0.

**SOT-89 Dimension**

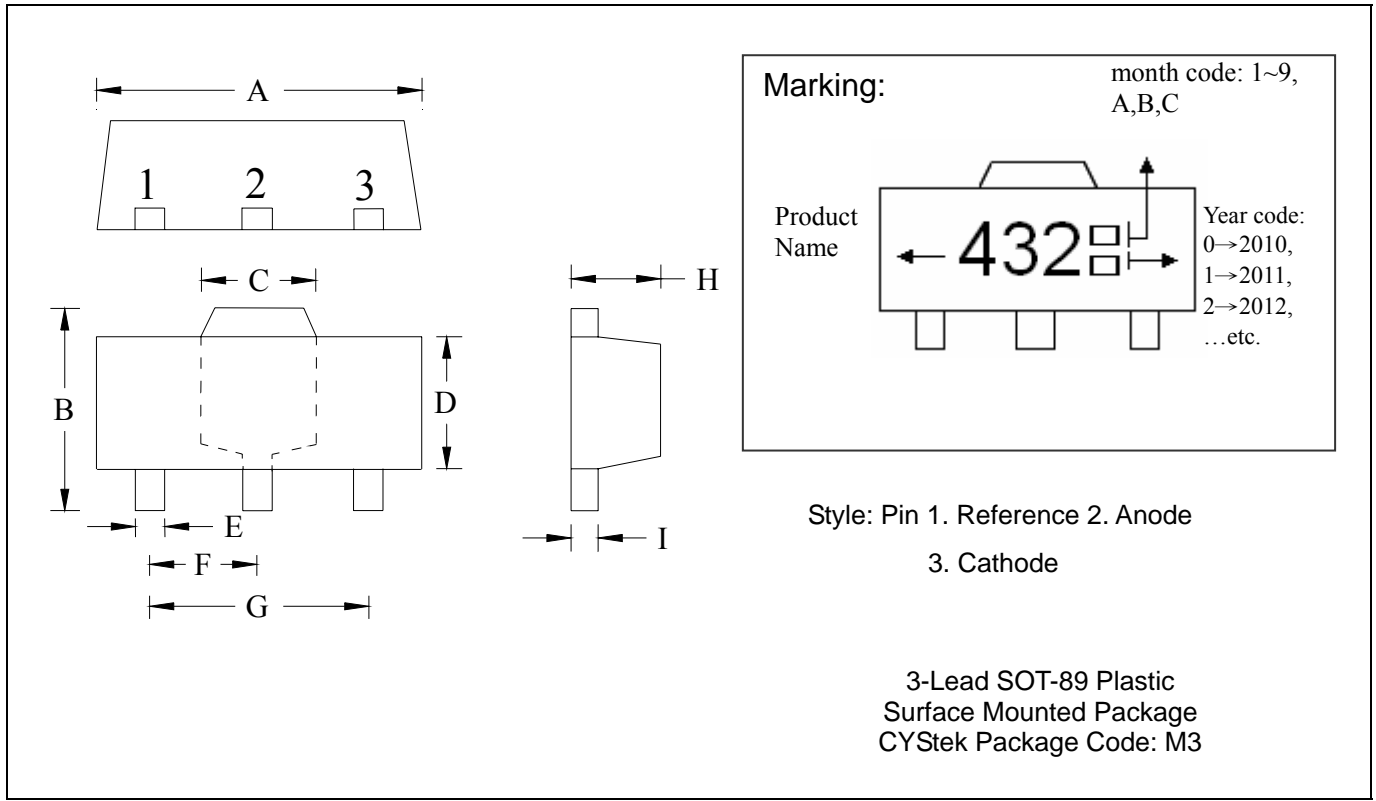

\*: Typical

DIM	Inches		Millimeters		DIM	Inches		Millimeters	
	Min.	Max.	Min.	Max.		Min.	Max.	Min.	Max.
A	0.1732	0.1811	4.40	4.60	F	0.0583	0.0598	1.48	1.527
B	0.1594	0.1673	4.05	4.25	G	0.1165	0.1197	2.96	3.04
C	0.0591	0.0663	1.50	1.70	H	0.0551	0.0630	1.40	1.60
D	0.0945	0.1024	2.40	2.60	I	0.0138	0.0161	0.35	0.41
E	0.01417	0.0201	0.36	0.51					

**Notes:** 1.Controlling dimension: millimeters.  
 2.Maximum lead thickness includes lead finish thickness, and minimum lead thickness is the minimum thickness of base material.  
 3.If there is any question with packing specification or packing method, please contact your local CYStek sales office.

**Material:**

- Lead: Pure tin plated.
- Mold Compound: Epoxy resin family, flammability solid burning class: UL94V-0.

**TO-92L Dimension**

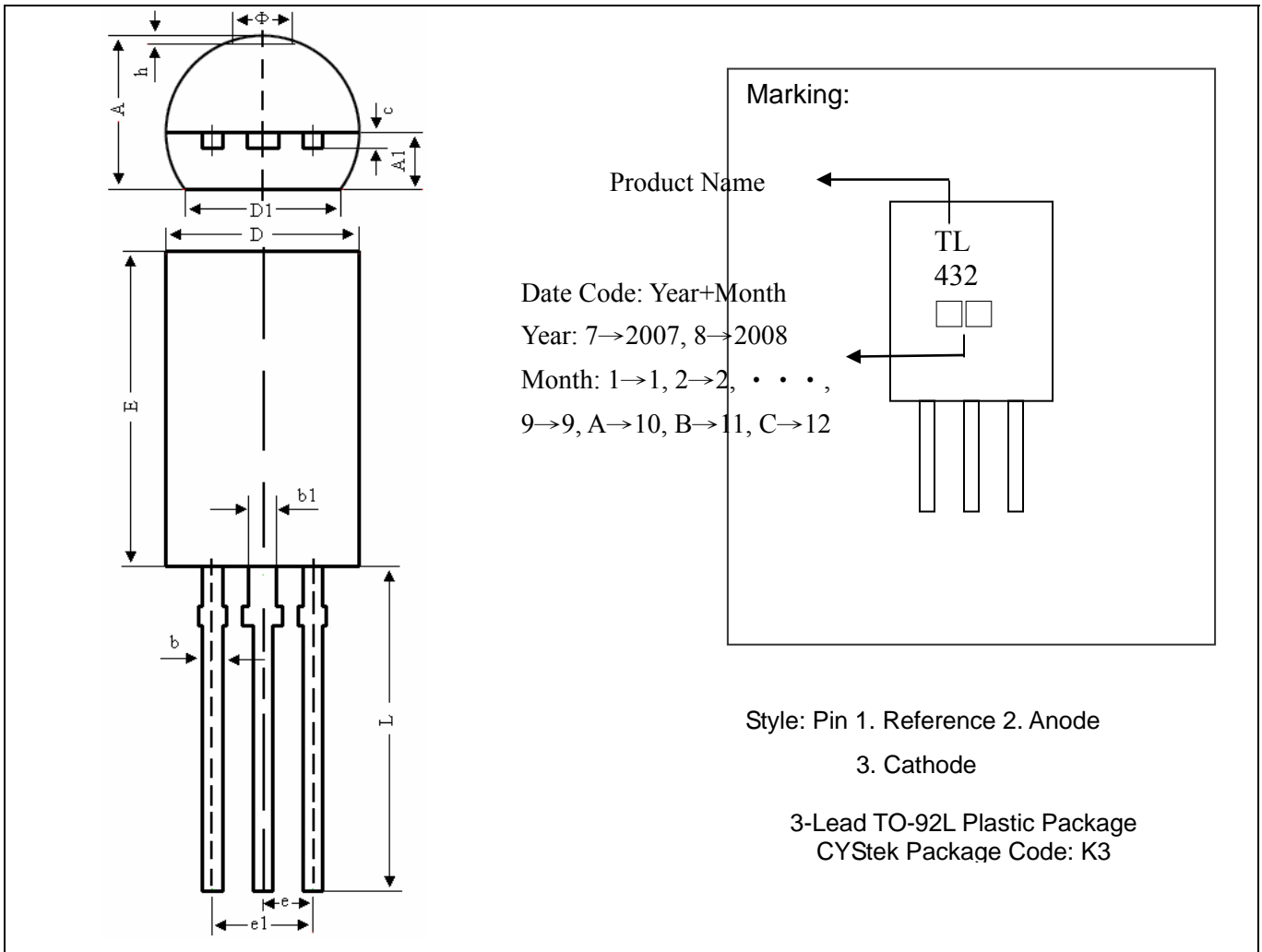

\*: Typical

DIM	Inches		Millimeters		DIM	Inches		Millimeters	
	Min.	Max.	Min.	Max.		Min.	Max.	Min.	Max.
A	0.146	0.161	3.700	4.100	E	0.307	0.323	7.800	8.200
A1	0.050	0.062	1.280	1.580	e	*0.05		*1.270	
b	0.014	0.022	0.350	0.550	e1	0.096	0.104	2.440	2.640
b1	0.024	0.031	0.600	0.800	L	0.543	0.559	13.800	14.200
c	0.014	0.018	0.350	0.450	phi	-	0.063	-	1.600
D	0.185	0.201	4.700	5.100	h	0.000	0.012	0.000	0.300
D1	0.157	-	4.000	-					

**Notes:** 1.Controlling dimension: millimeters.  
 2.Maximum lead thickness includes lead finish thickness, and minimum lead thickness is the minimum thickness of base material.  
 3.If there is any question with packing specification or packing method, please contact your local CYStek sales office.

**Material:**

- Lead: Pure tin plated.
- Mold Compound: Epoxy resin family, flammability solid burning class: UL94V-0.

**Important Notice:**

- All rights are reserved. Reproduction in whole or in part is prohibited without the prior written approval of CYStek.
- CYStek reserves the right to make changes to its products without notice.
- CYStek **semiconductor products are not warranted to be suitable for use in Life-Support Applications, or systems.**
- CYStek assumes no liability for any consequence of customer product design, infringement of patents, or application assistance.