

# Spezifikation für Freigabe / specification for release

Kunde / customer :

Artikelnummer / part number : **742794051**

LF



Bezeichnung : **Entstördrossel WE-ZB**  
description : **Line Choke WE-ZB**

DATUM / DATE : 2004-10-11

## A Mechanische Abmessungen / dimensions:

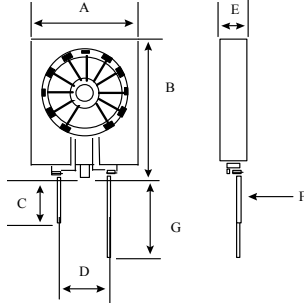

A	<b>8,0 max.</b>	mm
B	<b>9,5 max.</b>	mm
C	<b>15,5 ± 1,0</b>	mm
D	<b>5,0 ± 0,5</b>	mm
E	<b>3,5 max.</b>	mm
F	<b>∅ 0,6 ± 0,3</b>	mm
G	<b>19,5 ± 1,0</b>	mm

## B Elektrische Eigenschaften / electrical properties:

Eigenschaften / properties	Testbedingungen / test conditions		Wert / value	Einheit / unit	tol.
Induktivität / inductance	<b>1 kHz / 70mA</b>	L	<b>47,0</b>	μH	<b>±35%</b>
Impedanz / impedance	<b>100 MHz</b>	Z	<b>1700</b>	Ω	<b>typ.</b>
DC-Widerstand / DC-resistance		R <sub>DC</sub>	<b>50</b>	mΩ	<b>max.</b>
max. Strom / max. current		I <sub>DC</sub>	<b>500</b>	mA	<b>max.</b>
Nennspannung / rated voltage		U	<b>50</b>	V	<b>max.</b>

## C Lötpad / soldering spec.:

## D Prüfgeräte / test equipment:

**WK 3260B + 3265B** für/for L  
**HP 34401 A** für/for R<sub>DC</sub>  
**HP 34401 A** für/for I<sub>DC</sub>  
**HP 4396 B** für/for Z

## E Testbedingungen / test conditions:

Luftfeuchtigkeit / humidity: 33%  
Umgebungstemperatur / temperature: +20°C

## F Werkstoffe & Zulassungen / material & approvals:

Basismaterial / base material: Ferrit / ferrite  
Draht / wire: 2 UEWF 155°C

## G Eigenschaften / general specifications:

Lagertemperatur / storage temperature: -40°C - +125°C  
Betriebstemp. / operating temperature: -40°C - +85°C

Freigabe erteilt / general release:	<b>Kunde / customer</b>		
.....	.....		
Datum / date	Unterschrift / signature		
	<b>Würth Elektronik</b>		
.....	.....		
Geprüft / checked	Kontrolliert / approved		
	MST	Version 1	04-12-21
	Name	Änderung / modification	Datum / date

## Würth Elektronik eiSos GmbH & Co.KG

D-74638 Waldenburg · Max-Eyth-Strasse 1 - 3 · Germany · Telefon (+49) (0) 7942 - 945 - 0 · Telefax (+49) (0) 7942 - 945 - 400  
<http://www.we-online.com>

# Spezifikation für Freigabe / specification for release

Kunde / customer :  
 Artikelnummer / part number : **742794051**  
 Bezeichnung : **Entstördrossel WE-ZB**  
 description : **Line Choke WE-ZB**

LF



DATUM / DATE : 2004-10-11

## H Impedanzverlauf / impedance curve:

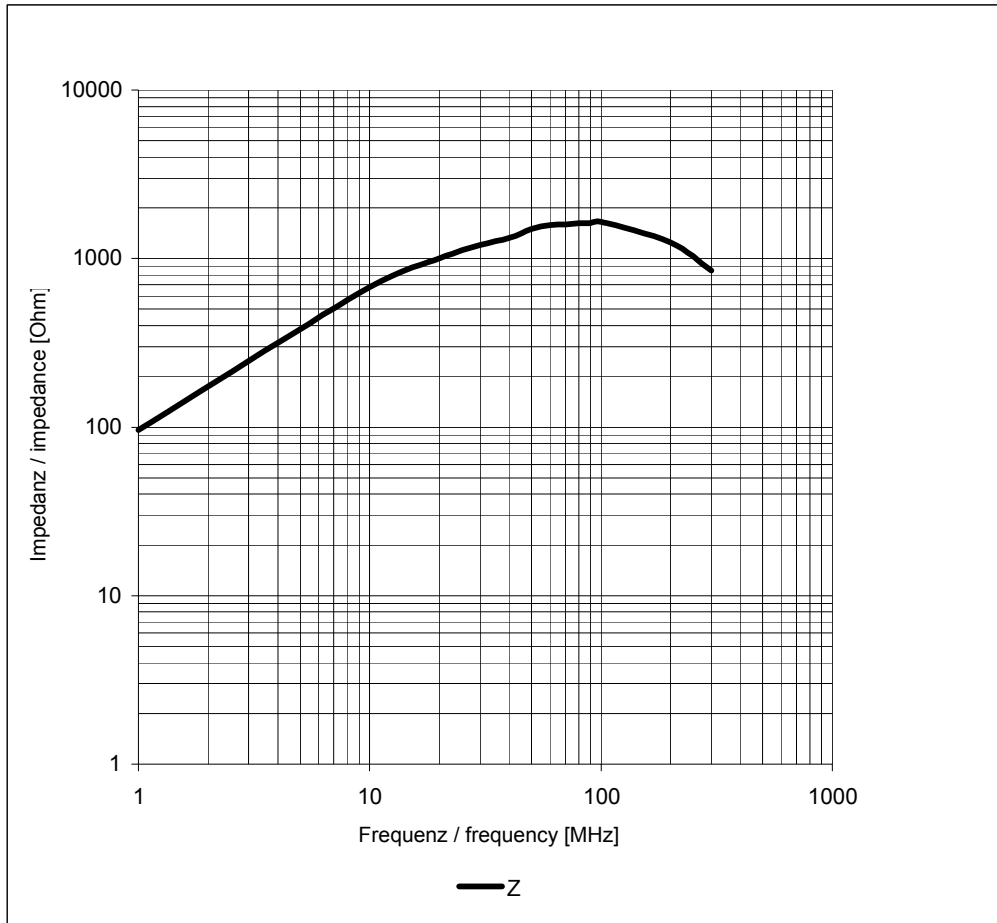

Freigabe erteilt / general release:	<b>Kunde / customer</b>			
.....	.....			
Datum / date	Unterschrift / signature			
	<b>Würth Elektronik</b>			
.....	.....			
Geprüft / checked	Kontrolliert / approved	MST	Version 1	04-12-21
		Name	Änderung / modification	Datum / date

This electronic component is designed and developed with the intention for use in general electronics equipments. Before incorporating the components into any equipments in the field such as aerospace, aviation, nuclear control, submarine, transportation, (automotive control, train control, ship control), transportation signal, disaster prevention, medical, public information network etc. where higher safety and reliability are especially required or if there is possibility of direct damage or injury to human body. In addition, even electronic component in general electronic equipments, when used in electrical circuits that require high safety, reliability functions or performance, the sufficient reliability evaluation-check for the safety must be performed before use. It is essential to give consideration when to install a protective circuit at the design stage.

### Würth Elektronik eiSos GmbH & Co.KG

D-74638 Waldenburg · Max-Eyth-Strasse 1 - 3 · Germany · Telefon (+49) (0) 7942 - 945 - 0 · Telefax (+49) (0) 7942 - 945 - 400  
<http://www.we-online.com>