

---

# Polygon Mirror Scanner Motor

---



---

# Polygon Mirror Scanner Motor

---

## ■ INTRODUCTION

This polygon mirror scanner motor is designed to rotate at a constant designated speed.

Polygon mirror scanner motor is core component in laser beam printer is applied OA appliance.

And this motor is used to deflect Laser beam of the polygon mirror.

It is need to spin at high speed to increase quantity of the print page. It is need to control by an accurate velocity because of the stability of the print quality.

## ■ FEATURE AND APPLICATION

### ● Feature

- Drive Circuit Inside
- Wide line-up from low speed to high speed
- Low Mechanical Noise & Vibration By Dynamic Bearing
- Low Jitter Dynamic Bearing
- External Clock Drive Method

### ● Application

- Laser Printer
- Digital PPC
- Laser PPF
- Bar code scanner, etc.

# Polygon Mirror Scanner Motor

## ■ STRUCTURE

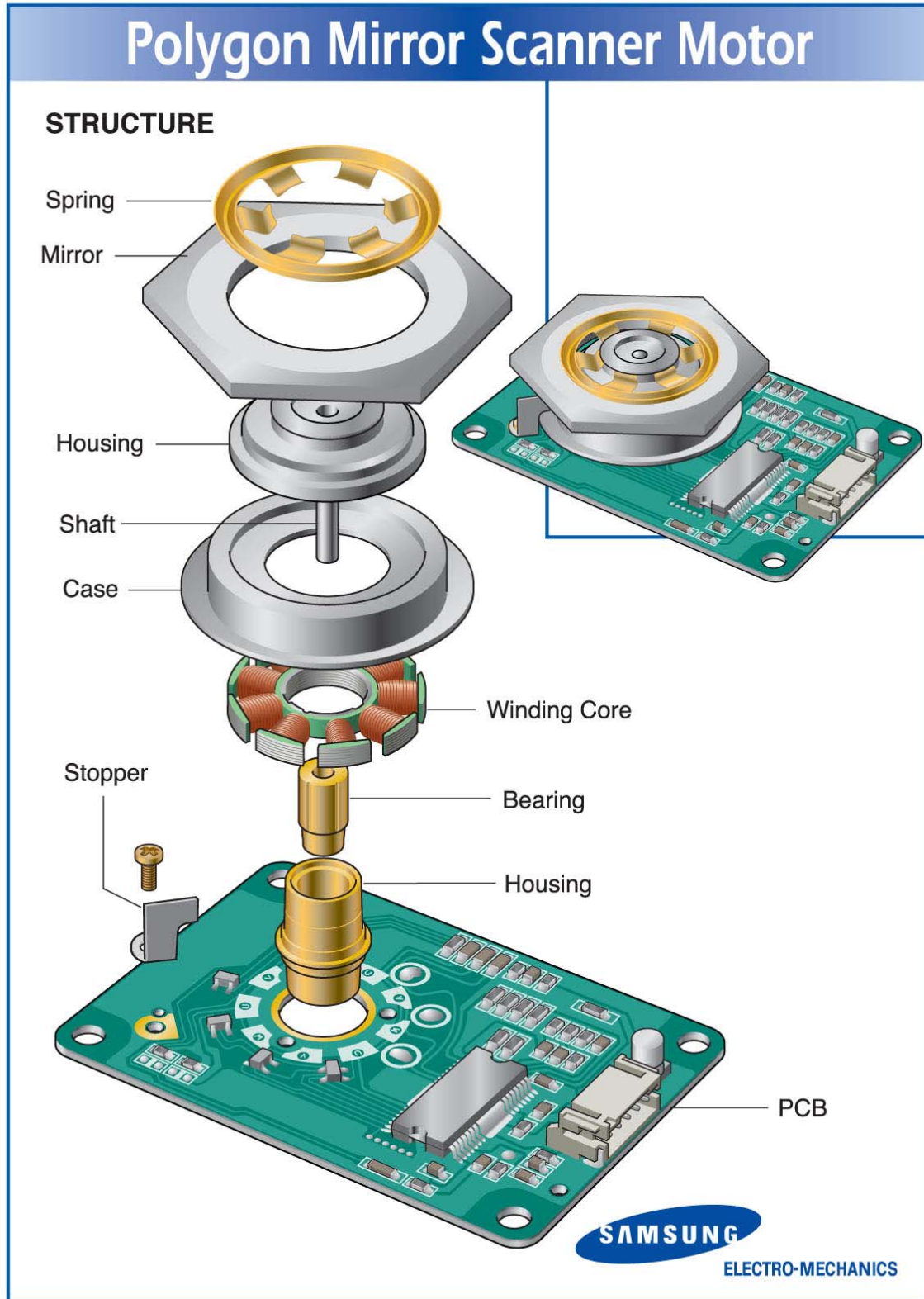

# Polygon Mirror Scanner Motor

## ■ APPEARANCE AND DIMENSION

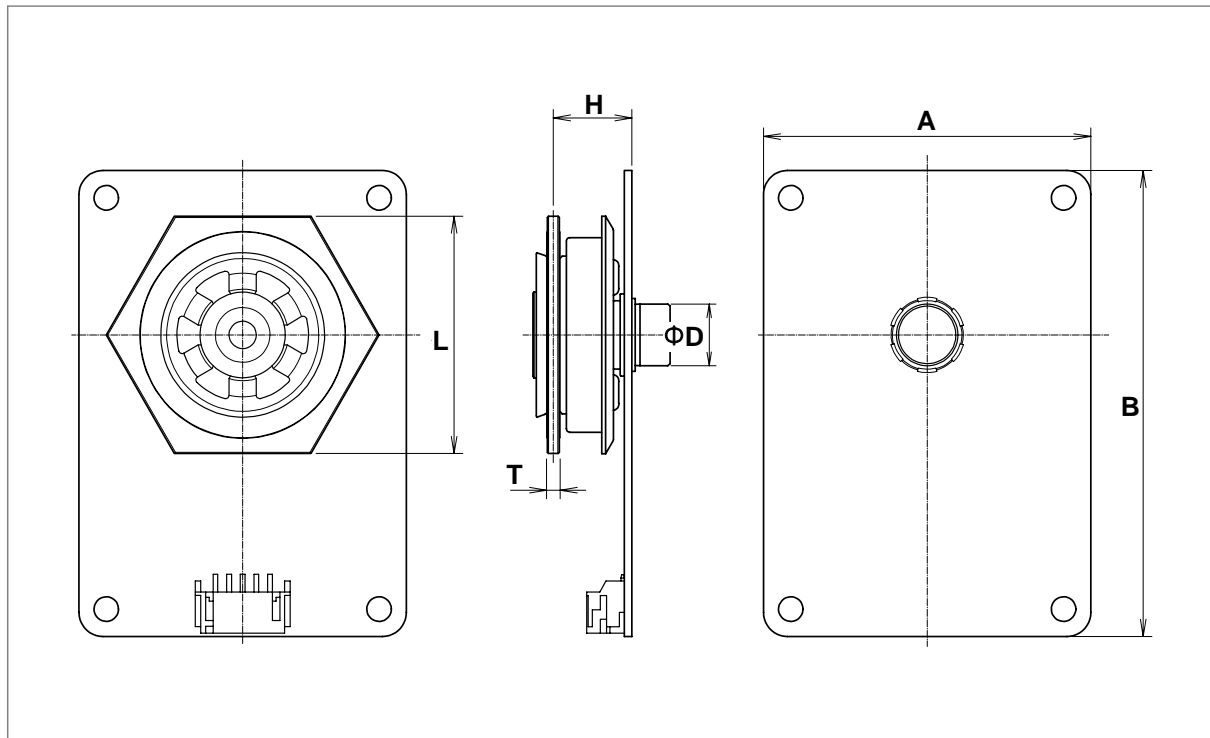

※ All standards will be able to confront in demand of the customer under discussing

MODEL	PCB SIZE (A x B)	OPTICAL HEIGHT (H)	MIRROR SIZE FACET x I.C.D(L) x T(T)	BOSS (ΦD)	
DMPSGC11A	48 x 68	13.5	F6 x 36.0 x T3.0	20.0	
DMPSGC14D		12.0	F6 x 34.64 x T2.0	9.0	
DMPSGC14E		12.0	F6 x 34.64 x T2.0	9.0	
DMPSGC14H		11.5	F6 x 34.64 x T2.0	9.0	
DMPSGC14G		11.5	F6 x 34.64 x T2.0	9.0	
DMPSGC26A		13.5	F6 x 34.64 x T2.0	9.0	
DMPSGC27A		11.0	F7 x 32.0 x T2.0	9.0	
DMPSGC34A		11.0	F6 x 34.64 x T2.0	9.0	
DMPSGC47A		11.0	F6 x 34.64 x T2.0	9.0	
DMPSGC54A		11.0	F7 x 32.0 x T2.0	9.0	
DMPSGC59A		11.0	F7 x 40.0 x T2.0	9.0	
DMPSGC62A		11.5	F6 x 34.64 x T2.0	9.0	
DMPSGC30A		56 x 115	10.7	F12 x 25 x T5.0	-

---

# Polygon Mirror Scanner Motor

---

## ■ PART NUMBERING

**DM**   **P**   **S**   **G**   **C**   **11**   **A**  
①   ②   ③   ④   ⑤   ⑥   ⑦

- ① Abbreviation of SAMSUNG DC Motor
- ② Application
- ③ Function of DC Motor
- ④ Structure of DC Motor
- ⑤ Type
- ⑥ Serial Number of Development Order
- ⑦ Minor-change

### ① Abbreviation of SAMSUNG DC Motor

### ② Application

Symbol	Application
P	LASER PRINTER

### ③ Function of DC Motor

Symbol	Function of DC Motor
S	SPINDLE SCANNER

### ④ Structure of DC Motor

Symbol	Structure of DC Motor
G	GENERAL

### ⑤ Type

Symbol	Type
C	CORE Type

---

# Polygon Mirror Scanner Motor

---

**⑥ Serial Number of Development Order**

Give a number from 00 to 99 in order of development.

**⑦ Minor-Change**

Give a character from A to Z in order of Minor-Change.

# Polygon Mirror Scanner Motor

## ■ PACKAGING

### ● EPS TRAY

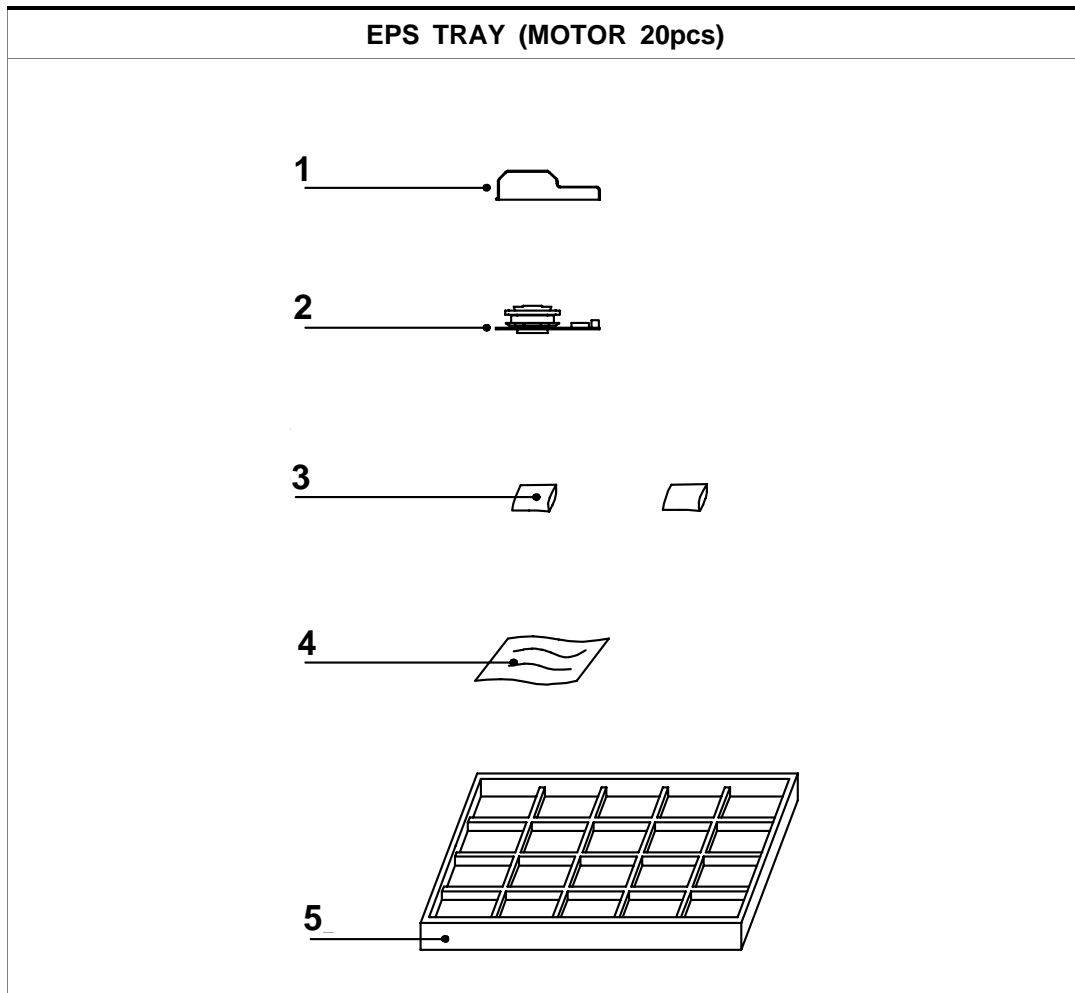

NO	ITEM	MATERIAL & SPEC	Q'TY / PALLET
1	CAP	POLYPROPYLENE, 69x50.5x23	1,800
2	MOTOR	68x48x19.6	1,800
3	SILICAGEL	3g	180
4	VINYL	VINYL, 100x80xT0.04	1,800
5	EPS TRAY	EPS#30, 514x338x50	108

# Polygon Mirror Scanner Motor

## ● OUTER CARTON BOX

**OUTER CARTON BOX (1 EMPTY TRAY, 5 TRAY WITH MOTORS)**

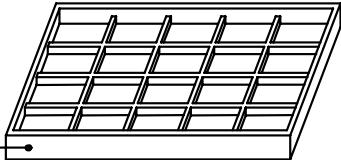

**EMPTY TRAY**

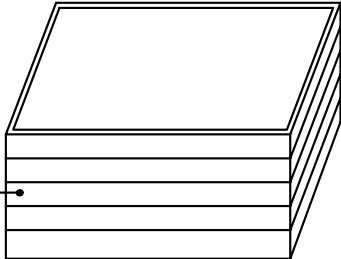

**5 TRAY**  
**MOTOR 100 PCS**  
**SILICAGEL 10 PCS**  
**(2PCS/TRAY)**

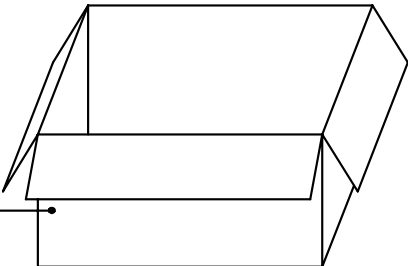

**6**

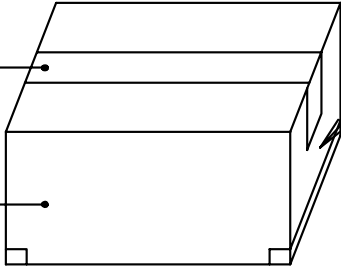

**7**

**6**

**SIDE MARKING**

MODEL	*****
Q'TY	100 EA
USER	*****
PART NO	
LOT NO	ABCDEF

**A BC DE F**

- └─ MOTOR Rev.(A : THE FIRST SPEC)
- └─ DAY
- └─ MONTH
- └─ THE END NUMBER OF YEAR

NO	ITEM	MATERIAL & SPEC	Q'TY / PALLET
6	OUTER BOX	CORRUGATED BOARD(A=A) 518x342x248 (INSIDE DIMENSION)	18
7	TAPE	POLYPROPYLENE, W50	18



# Polygon Mirror Scanner Motor

## ● PALLET

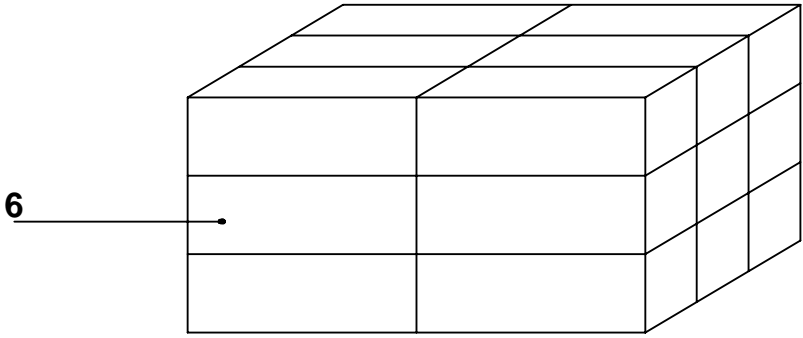
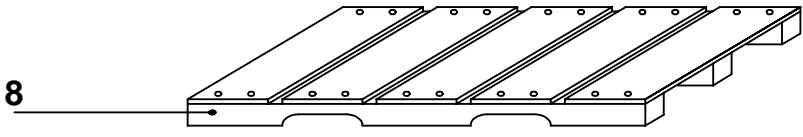
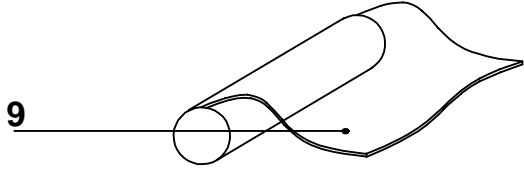
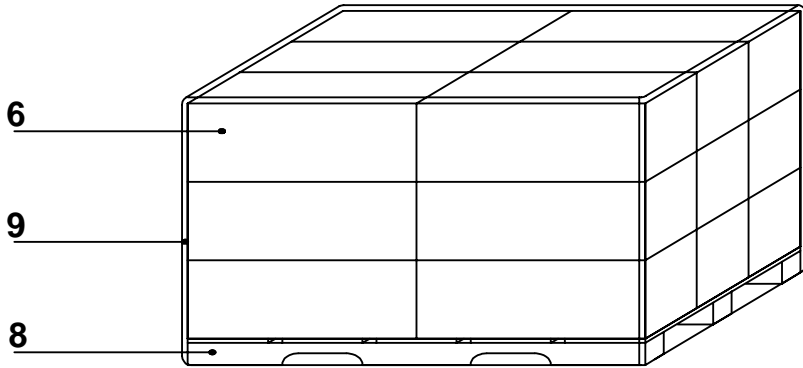
PALLET (18 CARTON BOX, MOTOR : 1,800 pcs)			
			
			
			
			
NO	ITEM	MATERIAL & SPEC	Q'TY / PALLET
8	PALLET	WOOD, 1,100x1,100x120	1
9	LDP	LOW DENSITY POYESTER W500, T0.025 LAPPED IT AROUND EACH FACES	1

# Polygon Mirror Scanner Motor

## ■ RELIABILITY TEST DATA

25[°C]·65[%RH] However, the conditions mentioned blow can be applied for testing as far as no technical problem Temperature : 10~35[°C], Relative humidity : 45~80[%RH]

No	Item	Measurement Conditions	Specifications (Example)
1	Starting current	Measured at 24[V] Measured at rated voltage and rated load	1.0 [A] or less
2	Rated current	Measured at rated voltage and rated load Measured in about 10[s] after motor starts	0.60 [A] or less
3	Start time	Time after the motor start and before the lock signal is output in the rated voltage, rated load.	3.5 [s] or less
		Time after the motor start and before the satisfaction of specifications in the rated voltage, rated load.	5.0 [s] or less
4	Jitter	<b>LF</b> (at 600 facet) Measured using a standard circuit and jig.	0.020 [%] or less
		<b>RF</b> (at 6 facet) Measured using a standard circuit and jig.	0.010 [%] or less
5	Dynamic balance	Measured using a balancer Mirror side	1[ $\text{mg} \cdot \text{cm}$ ]or less
		Measured using a balancer Rotor case side	1[ $\text{mg} \cdot \text{cm}$ ]or less
		Measured using a balancer Static	2[ $\text{mg} \cdot \text{cm}$ ] or less
6	Pyramid error of the mirror at operation	<b>Total</b> Measured by rotating the motor at the rated speed of rotation	150[~]p-p or less
		<b>Adjacent</b> Measured by rotating the motor at the rated speed of rotation	100[~]p-p or less
7	Noise	Measured 1[m] from the side of the motor	60 [dB-A] or less

# Polygon Mirror Scanner Motor

No	Item	Measurement Conditions	Specifications
1	Operating Environmental Conditions	No condensation	0~60[°C] 10~85[%RH]
2	Storage Environmental Conditions	No condensation	-40~70[°C] 10~90[%RH]
3	Withstand Vibration test	1.96[m/s <sup>2</sup> ] acceleration and 5~60~5[Hz], Period 15[min] Vibration for 30[min], each up-down, left-right, back-front, at operating	Rated value described in sections 1 to 7 shall be satisfied. (Specification for Characteristics)
		24.5[m/s <sup>2</sup> ] acceleration and 5~60~5[Hz], Period 15[min] Vibration for 30[min], each up-down, left-right, back-front, at non operating	
4	Withstand Shock test	980[m/s <sup>2</sup> ] acceleration and 11[ms] half sine wave shock for once each up-down, left-right, back-front, at operating	
5	Storage test	① 40[°C] 90[%RH] for 120[h] ② -40[°C] for 120[h] ③ 70[°C] for 120[h] No condensation	
6	Drop test of packed motor	1.2 [m]	
7	Heat shock test	-40[°C] , 70[°C] each 2[hr] 5 cycle	
8	Continuous use	Continuous operation shall be performed 3000[h] under the rated voltage and rated load.	
9	Interrupted Continuous use	The switching operation (10[sec] on and 30[sec] off) shall be performed 300,000times under the environmental conditions above	