

Version : 3.0

TECHNICAL SPECIFICATION

MODEL NO : PD080SL3

The content of this information is subject to be changed without notice.
Please contact PVI or its agent for further information.

Customer's Confirmation

Customer _____

Date _____

By _____

PVI's Confirmation

FOR MORE INFORMATION:

AZ DISPLAYS, INC.

75 COLUMBIA, ALISO VIEJO, CA 92656

[Http://www.AZDISPLAYS.com](http://www.AZDISPLAYS.com)

Confirmed By _____



Prepared By _____



Revision History

Rev.	Eng.	Issued Date	Revised Content
0.1	Sarah Huang	Oct 29, 2007	Preliminary
1.0	Sarah Huang	Jan 08, 2008	Add Page 25 15.Packing
2.0	Sarah Huang	Feb 25, 2008	Modify Page10 7. Electrical Characteristics: VIH from 0.7V _{CC} ~V _{CC} to 0.7V _{DD} ~V _{DD} VIL from 0~0.2V _{CC} to 0~0.2V _{DD}
3.0	李穎銘	Aug,20,2008	Add Page 23 13.Handling Cautions

TECHNICAL SPECIFICATION
CONTENTS

<i>NO.</i>	<i>ITEM</i>	<i>PAGE</i>
-	Cover	1
-	Revision History	2
-	Contents	3
1	Application	4
2	Features	4
3	Mechanical Specifications	4
4	Mechanical Drawing of TFT-LCD module	5
5	Connections and Functions for Interface Pins	7
6	Absolute Maximum Ratings	10
7	Electrical Characteristics	10
8	Pixel Arrangement	11
9	Display Colors and Input Data Signals	12
10	Input signal timing	15
11	Power On Sequence	19
12	Optical Characteristics	19
13	Handling Cautions	23
14	Reliability Test	24
15	Packing	25

1. Application

This data sheet applies to a color TFT LCD module; PD080SL3. The module applies to notebook PC, sub-note-book PC and other OA product, which require high quality flat panel display.

Prime View assumes no responsibility for any damage resulting from the use of the device which does not comply with the instructions and the precautions in these specification sheets.

2. Features

- . Amorphous silicon TFT LCD panel with LED backlight unit
- . Pixel in stripe configuration
- . Slim and compact, designed for O/A application
- . Display Colors : 262,144 colors or 16,777,216 colors
- . Backlight driving DC/AC inverter not included in this module

3. Mechanical Specifications

Parameter	Specifications	Unit
Screen Size	8 (diagonal)	inch
Display Format	800×(RGB)×600	dot
Display Colors	262,144	
Active Area	162(H)×121.5 (V)	mm
Pixel Pitch	0.2025 (H)×0.2025 (V)	mm
Pixel Configuration	Stripe	
Outline Dimension	200(W)×152(H)×10.5(D) (typ.)	mm
Weight	343±15	g
Back-light	42-LED	
Surface treatment	Anti-Glare+ SWV	
Display mode	Normally white	
Gray scale inversion direction	6 (Note 12-1)	o'clock

4. Mechanical Drawing of TFT-LCD Module

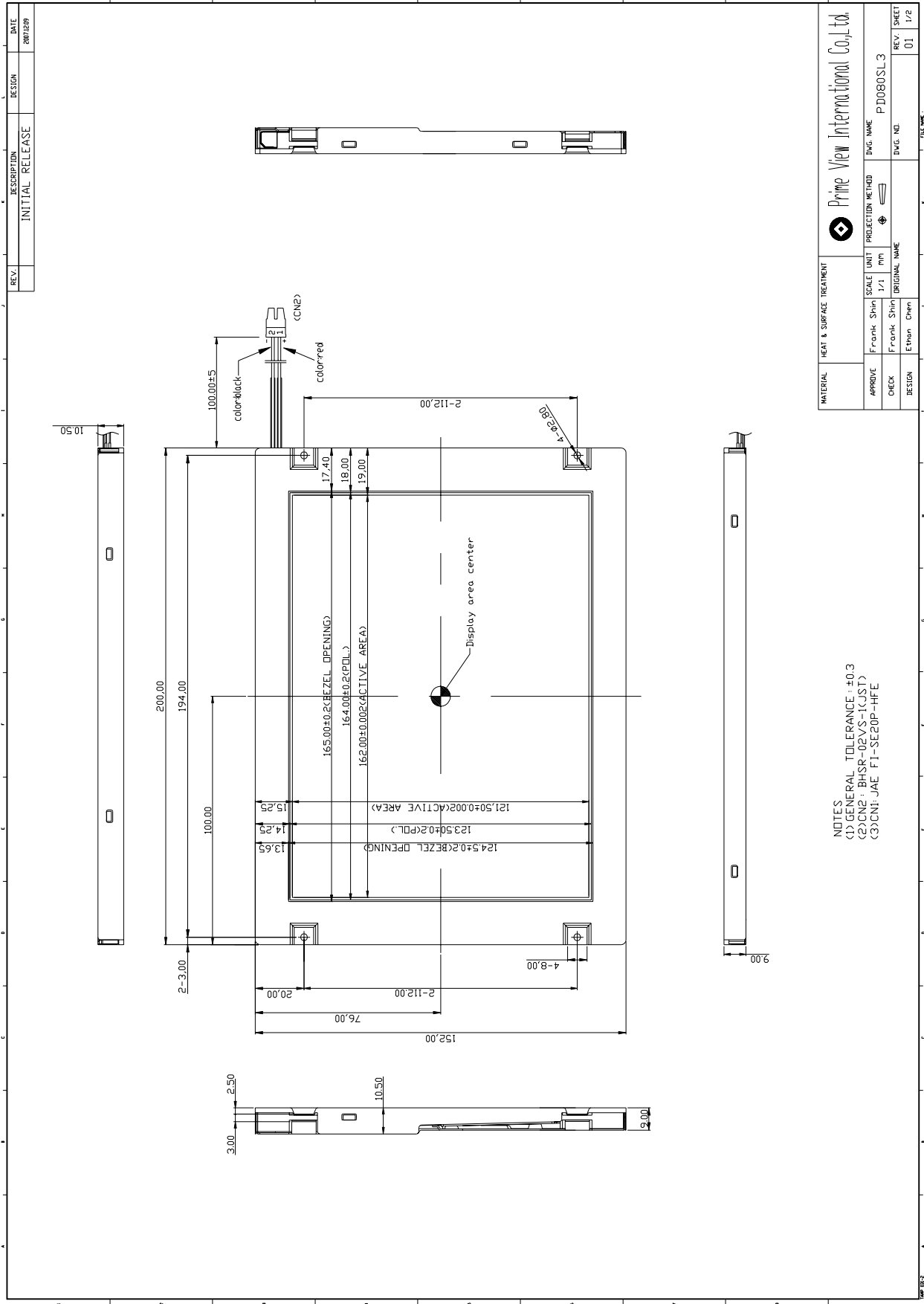

REV.	DESCRIPTION	DATE
	INITIAL RELEASE	20070909

MATERIAL	HEAT & SURFACE TREATMENT	Prime View International Co., Ltd.	
APPROVE	SCALE	UNIT	PROJECTION METHOD
CHECK	1:1	mm	1st
DESIGN	ORIGINAL NAME	DWG. NAME	REV. SHEET
		PD080SL3	01 1/1

NOTES
 (1) GENERAL TOLERANCE: ±0.3
 (2) CNC2: BHSR-02VS-1(CST)
 (3) CNC1: JAE FT-SE20P-HFE

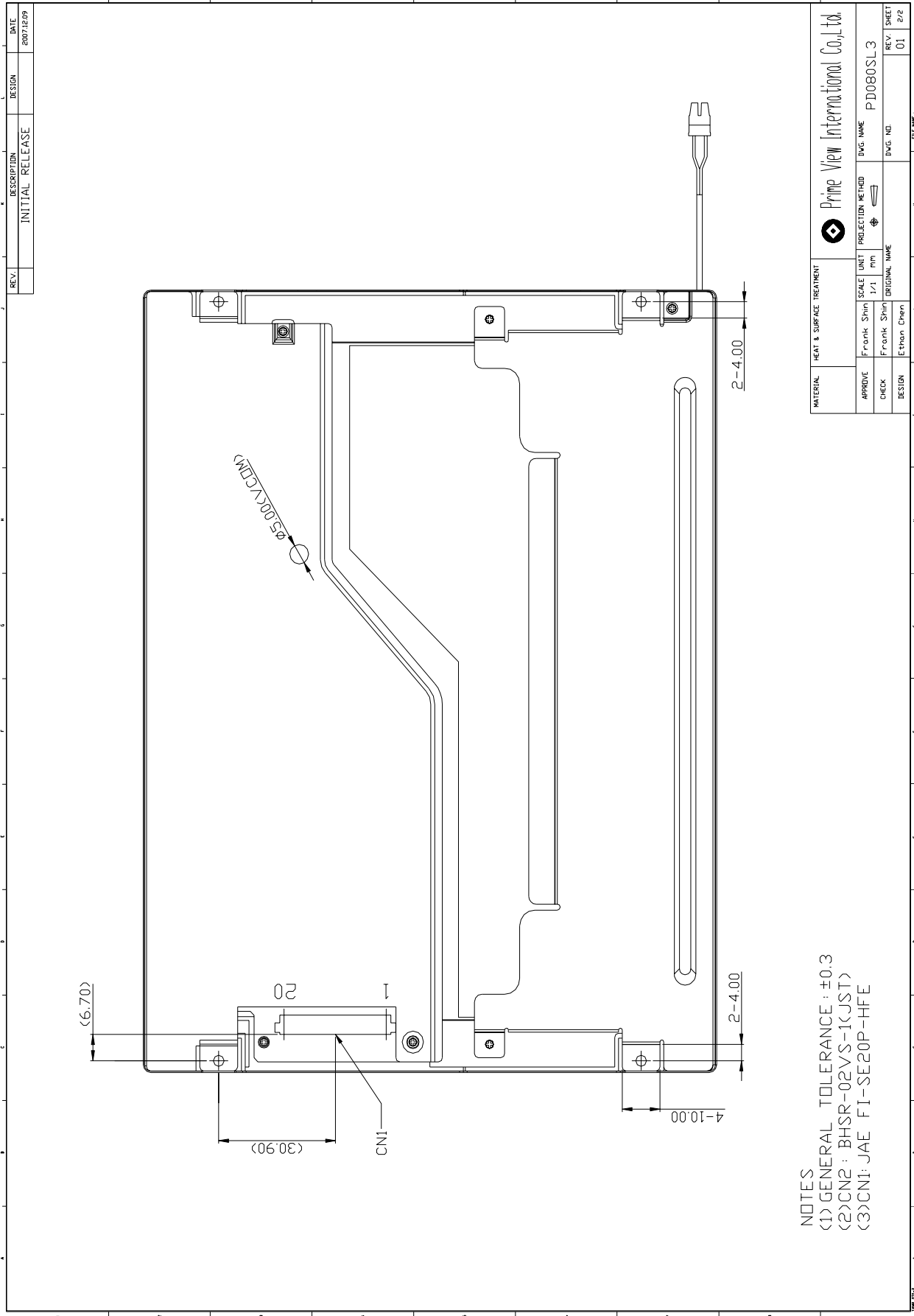

REV.	DESCRIPTION	DESIGN	DATE
	INITIAL RELEASE		2007.12.19

MATERIAL		HEAT & SURFACE TREATMENT		Prime View International Co., Ltd.	
APPROVE	Frank Shin	SCALE	UNIT	DWG. NAME	PD080SL3
CHECK	Frank Shin	1/1	mm	PROJECTION METHOD	
DESIGN	Ethan Chen			ORIGINAL NAME	
				DWG. NO.	REV. SHEET
					01 / 02

- NOTES
- (1) GENERAL TOLERANCE : ±0.3
 - (2) CN2 : BHSR-02VS-1<JST>
 - (3) CN1 : JAE FI-SE20P-HFE

5. CONNECTIONS AND FUNCTIONS FOR INTERFACE PINS
5-1) LCD panel signal processing board
CN1 socket (LCD module side): FI-SE20P-HFE(Japan Aviation Electronics Industry Limited(JAE))

Pin No.	Symbol	Signal	Remarks
1	A	D3+	Pixel data Note 5 - 1, 5 - 3
	B	GND	Ground Note 5 - 4
2	A	D3-	Pixel data Note 5 - 1, 5 - 3
	B	GND	Ground Note 5 - 4
3	DPS	Selection of scan direction	High: Reverse scan Low or Open: Normal scan Note 5 - 2
4	FRC	Selection of the number of colors	High: 16,777,216 colors Low or Open: 262,144 colors Note 5 - 1
5	GND	Ground	Note 5 - 4
6	CK+	Pixel clock	Note 5 - 3
7	CK-		
8	GND	Ground	Note 5 - 4
9	D2+	Pixel data	Note 5 - 3
10	D2-		
11	GND	Ground	Note 5 - 4
12	D1+	Pixel data	Note 5 - 3
13	D1-		
14	GND	Ground	Note 5 - 4
15	D0+	Pixel data	Note 5 - 3
16	D0-		
17	GND	Ground	Note 5 - 4
18	GND		
19	VDD	Power supply	Note 5 - 4
20	VDD		

Note 5 - 1 : See **DISPLAY COLORS AND INPUT DATA SIGNALS** .

Note 5 - 2 : See **SCANNING DIRECTIONS** .

Note 5 - 3 : Twist pair wires with 100Ω (Characteristic impedance) should be connected between LCD panel signal processing board and LVDS transmitter.

Note 5 - 4 : All GND and VDD terminals should be used without any non-connected lines.

5-2) Connection between receiver and transmitter for LVDS

(1) Input data signal: 8bit

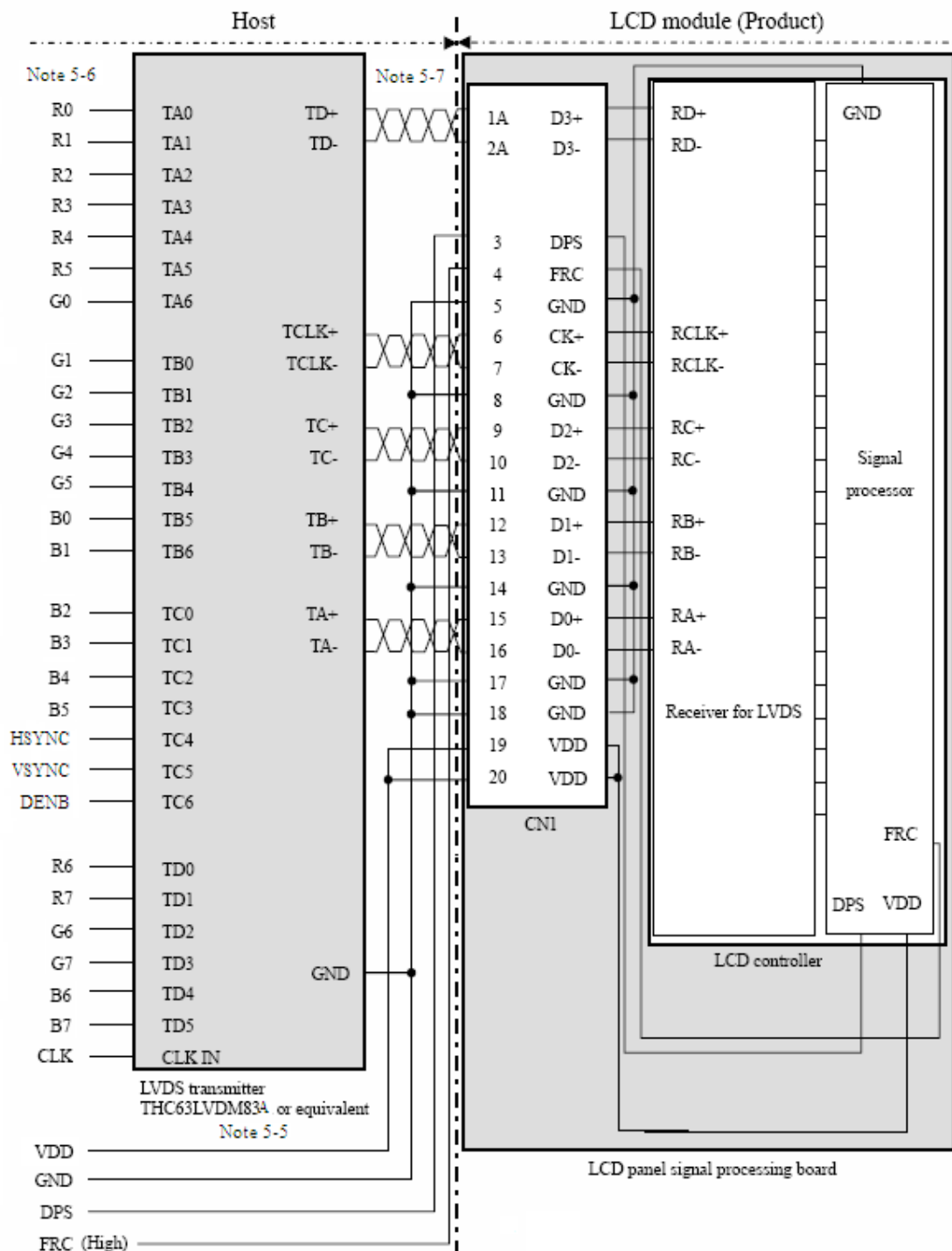

- Note 5-5 : Recommended transmitter THC63LVDM83A (THine Electronics Inc.) or equivalent
- Note 5-6 : LSB (Least Significant Bit) - R0, G0, B0 MSB (Most Significant Bit) - R7, G7, B7
- Note 5-7 : Twist pair wires with 100Ω (Characteristic impedance) should be connected between LCD panel signal processing board and LVDS transmitter.

(2) Input data signal: 6bit

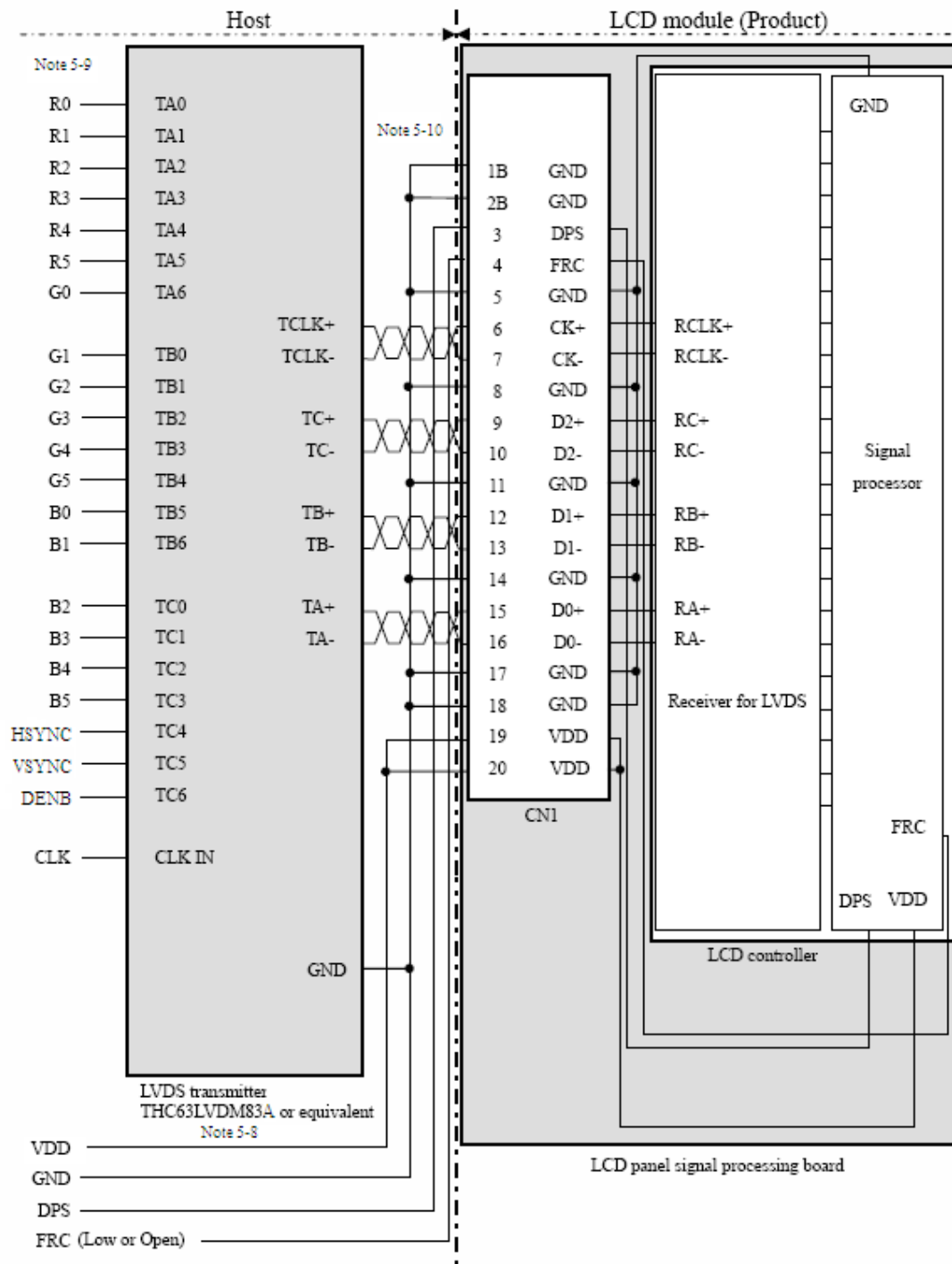

- Note 5-8 : Recommended transmitter THC63LVDM83A (THine Electronics Inc.) or equivalent
- Note 5-9 : LSB (Least Significant Bit) – R0, G0, B0 MSB (Most Significant Bit) – R5, G5, B5
- Note 5-10: Twist pair wires with 100Ω (Characteristic impedance) should be connected between LCD panel signal processing board and LVDS transmitter.

DENB input signal.

If customer wanted to off the DENB mode , you must keep the DENB always High or Low.

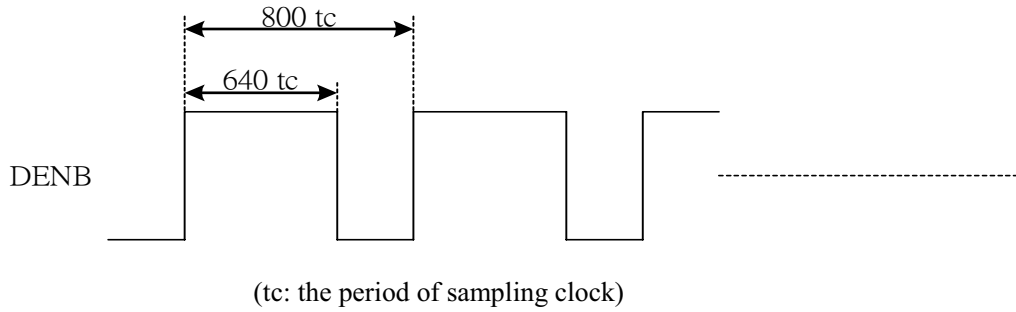

6. Absolute Maximum Ratings

GND=0V, Ta=25°C

Parameters	Symbol	MIN.	MAX.	Unit	Remark
Supply Voltage	V _{DD}	-0.3	+4.0	V	
Input Signals Voltage	V _{IN}	-0.3	V _{DD} +0.3	V	Note 6-1

Note 6-1: LVDS signal.

7. Electrical Characteristics

7-1) Recommended Operating Conditions:

GND = 0V , Ta = 25°C

Item	Symbol	Min.	Typ.	Max.	Unit	Remark
Supply Voltage	V _{DD}	3.0	3.3	3.6	V	
Current Dissipation	I _{DD}	-	153	-	mA	Note 7-1
Total power consumption	P _{DD}	0.46	0.51	0.56	W	
LVDS Differential input high threshold	V _{TH}	-	-	100	mV	Note 7-2
LVDS Differential input low threshold	V _{TL}	-100	-	-	-	
Input voltage for DPS & FPC signal	High	V _{IH}	0.7 V _{DD}	-	V _{DD}	V
	Low	V _{IL}	0	-	0.2 V _{DD}	V

Note 7-1 : To test the current dissipation of V_{DD}, using the “color bars” testing pattern shown as below.

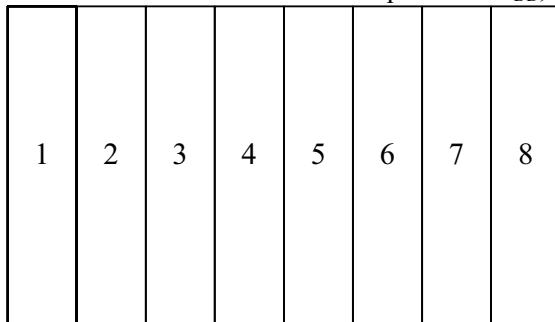

1. White
2. Yellow
3. Cyan
4. Green
5. Magenta
6. Red
7. Blue
8. Black

I_{DD} current dissipation testing pattern

Note7-2 : Please refers to THC63LVDM83A specification by Thin Corporation. This LCD module conforms to LVDS standard.

7-2) Recommended Driving Condition for Back Light

Ta = 25°C

Parameter	Symbol	Min	TYP	MAX	Unit	Remark
Supply voltage of LED backlight	V _{LED}	-	-	(11)	V	Note 7-3
Supply current of LED backlight	I _{LED}	-	20	-	mA	Note 7-4
Backlight Power Consumption	P _{LED}	-	-	3.08	W	Note 7-3/7-5

Note 7-3 : I_{LED}= 20mA,constant current

Note 7-4 : The LED driving condition is defined for each LED module. (3 LED Serial)

Input current = 20mA * 14 = 280mA

Note 7-5 : P_{LED} = V_{LED-1} * I_{LED-1} + V_{LED-2} * I_{LED-2} + V_{LED-13} * I_{LED-13} + V_{LED-14} * I_{LED-14}

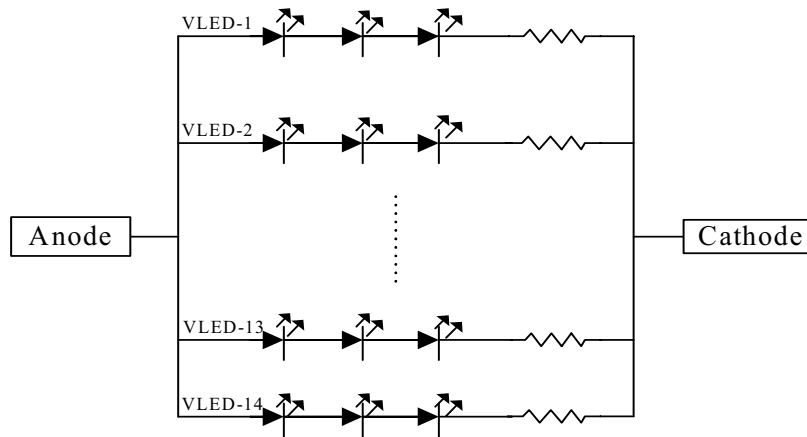

7-3) Backlight driving

Connector type : BHSR-02VS-1(JST)

PIN NO.	Symbol	Description	Remark
1	+	Input terminal (Anode)	Red
2	-	Input terminal (Cathode)	Black

8. Pixel Arrangement

The LCD module pixel arrangement is the stripe.

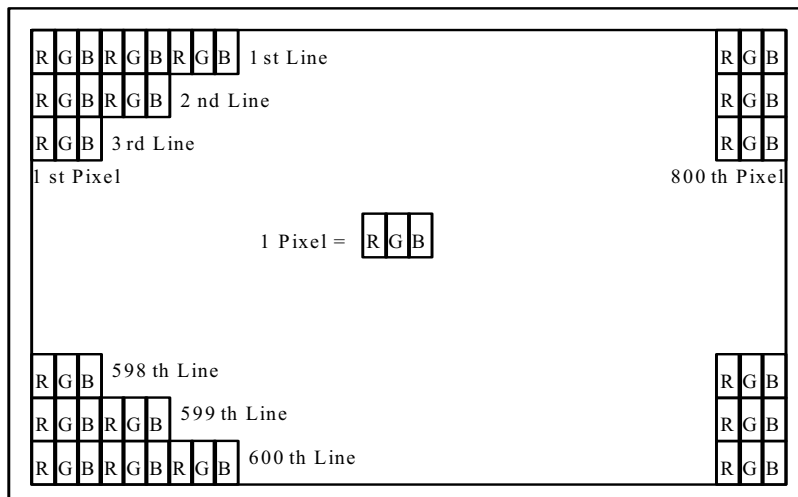

9. Display Colors and Input Data Signals

9-1) Combinations between input data signals and FRC signal

This product can display in equivalent to 16,777,216 colors in 256 gray scales and 262,144 colors in 64 gray scales by combination between input data signals and FRC signal. See following table.

Combination	Input data signals	CN1-Pin No.1 and 2	FRC terminal	Display colors	Remarks
①	8-bit	D3+/-	High	16,777,216	Note 9-1
②	6-bit	GND	Low or Open	262,144	Note 9-2

Note 9-1 : See " 9-2) 16,777,216 colors".

Note 9-2 : See " 9-3) 262,144 colors".

9-2) 16,777,216 colors

This product can display equivalent of 16,777,216 colors in 256 gray scales by combination ①

Display colors		Data signal (0: Low level, 1: High level)																							
		R7	R6	R5	R4	R3	R2	R1	R0	G7	G6	G5	G4	G3	G2	G1	G0	B7	B6	B5	B4	B3	B2	B1	B0
Basic Colors	Black	0	0	0	0	0	0	0	0	0	0	0	0	0	0	0	0	0	0	0	0	0	0	0	0
	Blue	0	0	0	0	0	0	0	0	0	0	0	0	0	0	0	0	1	1	1	1	1	1	1	1
	Red	1	1	1	1	1	1	1	1	0	0	0	0	0	0	0	0	0	0	0	0	0	0	0	0
	Magenta	1	1	1	1	1	1	1	1	0	0	0	0	0	0	0	0	1	1	1	1	1	1	1	1
	Green	0	0	0	0	0	0	0	0	1	1	1	1	1	1	1	1	0	0	0	0	0	0	0	0
	Cyan	0	0	0	0	0	0	0	0	1	1	1	1	1	1	1	1	1	1	1	1	1	1	1	1
	Yellow	1	1	1	1	1	1	1	1	1	1	1	1	1	1	1	1	0	0	0	0	0	0	0	0
	White	1	1	1	1	1	1	1	1	1	1	1	1	1	1	1	1	1	1	1	1	1	1	1	1
Red gray scale	Black	0	0	0	0	0	0	0	0	0	0	0	0	0	0	0	0	0	0	0	0	0	0	0	0
		0	0	0	0	0	0	0	1	0	0	0	0	0	0	0	0	0	0	0	0	0	0	0	0
	dark	0	0	0	0	0	0	1	0	0	0	0	0	0	0	0	0	0	0	0	0	0	0	0	0
	↑					:																			
	↓					:																			
	bright	1	1	1	1	1	1	0	1	0	0	0	0	0	0	0	0	0	0	0	0	0	0	0	0
Red	1	1	1	1	1	1	1	0	0	0	0	0	0	0	0	0	0	0	0	0	0	0	0	0	
Red	1	1	1	1	1	1	1	1	0	0	0	0	0	0	0	0	0	0	0	0	0	0	0	0	
Green gray scale	Black	0	0	0	0	0	0	0	0	0	0	0	0	0	0	0	0	0	0	0	0	0	0	0	0
		0	0	0	0	0	0	0	0	0	0	0	0	0	0	0	1	0	0	0	0	0	0	0	0
	dark	0	0	0	0	0	0	0	0	0	0	0	0	0	0	1	0	0	0	0	0	0	0	0	0
	↑					:																			
	↓					:																			
	bright	0	0	0	0	0	0	0	0	1	1	1	1	1	1	0	1	0	0	0	0	0	0	0	0
Green	0	0	0	0	0	0	0	0	1	1	1	1	1	1	1	0	0	0	0	0	0	0	0	0	
Green	0	0	0	0	0	0	0	0	1	1	1	1	1	1	1	1	0	0	0	0	0	0	0	0	
Blue gray scale	Black	0	0	0	0	0	0	0	0	0	0	0	0	0	0	0	0	0	0	0	0	0	0	0	0
		0	0	0	0	0	0	0	0	0	0	0	0	0	0	0	0	0	0	0	0	0	0	0	1
	dark	0	0	0	0	0	0	0	0	0	0	0	0	0	0	0	0	0	0	0	0	0	0	1	0
	↑					:																			
	↓					:																			
	bright	0	0	0	0	0	0	0	0	0	0	0	0	0	0	0	0	1	1	1	1	1	1	0	1
Blue	0	0	0	0	0	0	0	0	0	0	0	0	0	0	0	0	1	1	1	1	1	1	1	0	
Blue	0	0	0	0	0	0	0	0	0	0	0	0	0	0	0	0	1	1	1	1	1	1	1	1	

9-3) 262,144 colors

This product can display equivalent of 262,144 colors in 64 gray scales by combination ②

Display colors		Data signal (0: Low level, 1: High level)																	
		R5	R4	R3	R2	R1	R0	G5	G4	G3	G2	G1	G0	B5	B4	B3	B2	B1	B0
Basic colors	Black	0	0	0	0	0	0	0	0	0	0	0	0	0	0	0	0	0	0
	Blue	0	0	0	0	0	0	0	0	0	0	0	0	1	1	1	1	1	1
	Red	1	1	1	1	1	1	0	0	0	0	0	0	0	0	0	0	0	0
	Magenta	1	1	1	1	1	1	0	0	0	0	0	0	1	1	1	1	1	1
	Green	0	0	0	0	0	0	1	1	1	1	1	1	0	0	0	0	0	0
	Cyan	0	0	0	0	0	0	1	1	1	1	1	1	1	1	1	1	1	1
	Yellow	1	1	1	1	1	1	1	1	1	1	1	1	0	0	0	0	0	0
	White	1	1	1	1	1	1	1	1	1	1	1	1	1	1	1	1	1	1
Red gray scale	Black	0	0	0	0	0	0	0	0	0	0	0	0	0	0	0	0	0	0
		0	0	0	0	0	1	0	0	0	0	0	0	0	0	0	0	0	0
	dark	0	0	0	0	1	0	0	0	0	0	0	0	0	0	0	0	0	0
	↑																		
	↓																		
	bright	1	1	1	1	0	1	0	0	0	0	0	0	0	0	0	0	0	0
	1	1	1	1	1	0	0	0	0	0	0	0	0	0	0	0	0	0	
	1	1	1	1	1	1	0	0	0	0	0	0	0	0	0	0	0	0	
Green gray scale	Black	0	0	0	0	0	0	0	0	0	0	0	0	0	0	0	0	0	0
		0	0	0	0	0	0	0	0	0	0	1	0	0	0	0	0	0	0
	dark	0	0	0	0	0	0	0	0	0	1	0	0	0	0	0	0	0	0
	↑																		
	↓																		
	bright	0	0	0	0	0	0	1	1	1	1	0	1	0	0	0	0	0	0
	0	0	0	0	0	0	1	1	1	1	1	0	0	0	0	0	0	0	
	0	0	0	0	0	0	1	1	1	1	1	1	0	0	0	0	0	0	
Blue gray scale	Black	0	0	0	0	0	0	0	0	0	0	0	0	0	0	0	0	0	0
		0	0	0	0	0	0	0	0	0	0	0	0	0	0	0	0	0	1
	dark	0	0	0	0	0	0	0	0	0	0	0	0	0	0	0	0	1	0
	↑																		
	↓																		
	bright	0	0	0	0	0	0	0	0	0	0	0	0	1	1	1	1	0	1
	0	0	0	0	0	0	0	0	0	0	0	0	1	1	1	1	1	0	
	0	0	0	0	0	0	0	0	0	0	0	0	1	1	1	1	1	1	

9-4) DISPLAY POSITIONS

The following table is the coordinates per pixel (See " 9-5) SCANNING DIRECTIONS").

C (0, 0)						
R	G	B				
C(0, 0)	C(1, 0)	...	C(X, 0)	...	C(798, 0)	C(799, 0)
C(0, 1)	C(1, 1)	...	C(X, 1)	...	C(798, 1)	C(799, 1)
.
.
.
C(0, Y)	C(1, Y)	...	C(X, Y)	...	C(798, Y)	C(799, Y)
.
.
.
C(0, 598)	C(1, 598)	...	C(X, 598)	...	C(798, 598)	C(799, 598)
C(0, 599)	C(1, 599)	...	C(X, 599)	...	C(798, 599)	C(799, 599)

9-5) SCANNING DIRECTIONS

The following figures are seen from a front view. Also the arrow shows the direction of scan.

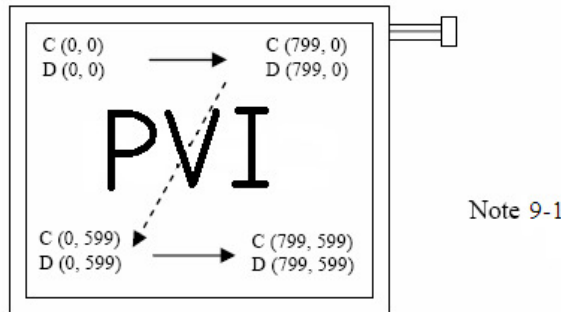

Figure1. Normal scan (DPS: Low or Open)

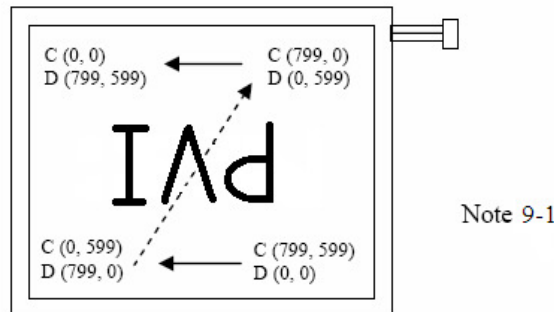

Figure2. Reverse scan (DPS: High)

Note1: Meaning of C (X, Y) and D (X, Y)

C (X, Y): The coordinates of the display position (See " 9-4) DISPLAY POSITIONS".)

D (X, Y): The data number of input signal for LCD panel signal processing board

10. Input signal timing:

DENB pin have high priority than SYNC mode(HSVC+VSYNC). When IC only use SYNC pin, DENB pin have to connect to ground.

(A) Timing Specifications (DENB Mode):

Item	Symbol	Min.	Typ.	Max.	Unit	Remark
Frame Cycling Period	t1	604 X t3	628 X t3	800 X t3	-	
		14	16.58	20	ms	
Vertical Display Period	t2	600 X t3	600 X t3	600 X t3	-	
Horizontal Scanning Time	t3	920 X t5	1056 X t5	1064 X t5	-	
		24	26.4	33	μ s	
Horizontal Display Period	t4	800 X t5	800 X t5	800 X t5	-	
Clock Cycle	t5	20	25.0	31.25	ns	
Clock High Level Time	t6	9.0	-	-	ns	
Clock Low Level Time	t7	9.0	-	-	ns	
Hold time	t8	4.0	-	-	ns	
Set-up time	t9	5.0	-	-	ns	

(B) Timing Specifications (SYNC Mode)

Item	Symbol	Min.	Typ.	Max.	Unit	Remark	
HSYNC	Period	24	26.4	33	us		
		920	1056	1064	tc		
	Display period	Hdp	800	800	800	tc	
	Pulse width	Hpw	12	128	202	tc	
	Back-porch	Hbp	12	86	202	tc	
	Front-porch	Hfp	42	42	42	tc	
	Hpw+Hbp		214	214	214	tc	
	Hsync-CLK	Hhc	10	-	Tc-10	ns	
Vsync-Hsync	Hvh	0	0	200	tc		
VSYNC	Period (Frame cycling period)	Vp	14	16.58	20	ms	Note 1
			604	628	800	Hp	
	Display period	Vdp	600	600	600	Hp	
	Pulse width	Vpw	2	4	27	Hp	
	Back-porch	Vbp	0	23	25	Hp	
	Front-porch	Vfp	1	1	1	Hp	
	Vpw+Vbp		27	27	27	Hp	

Note 1: Frame cycling period is optimum in 16.58ms.(60HZ)

(C)Timing Chart:

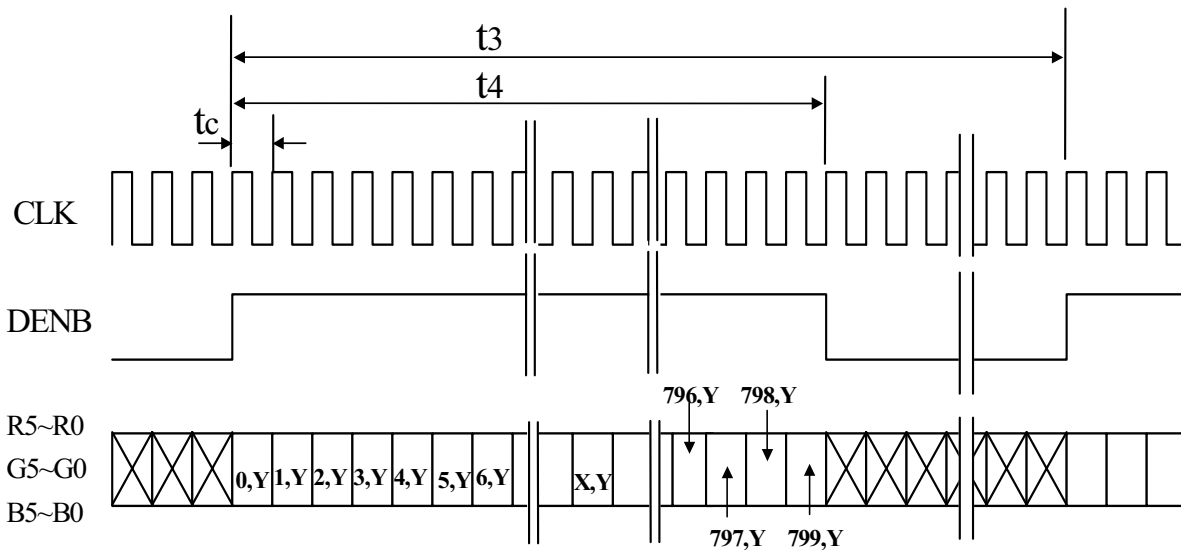
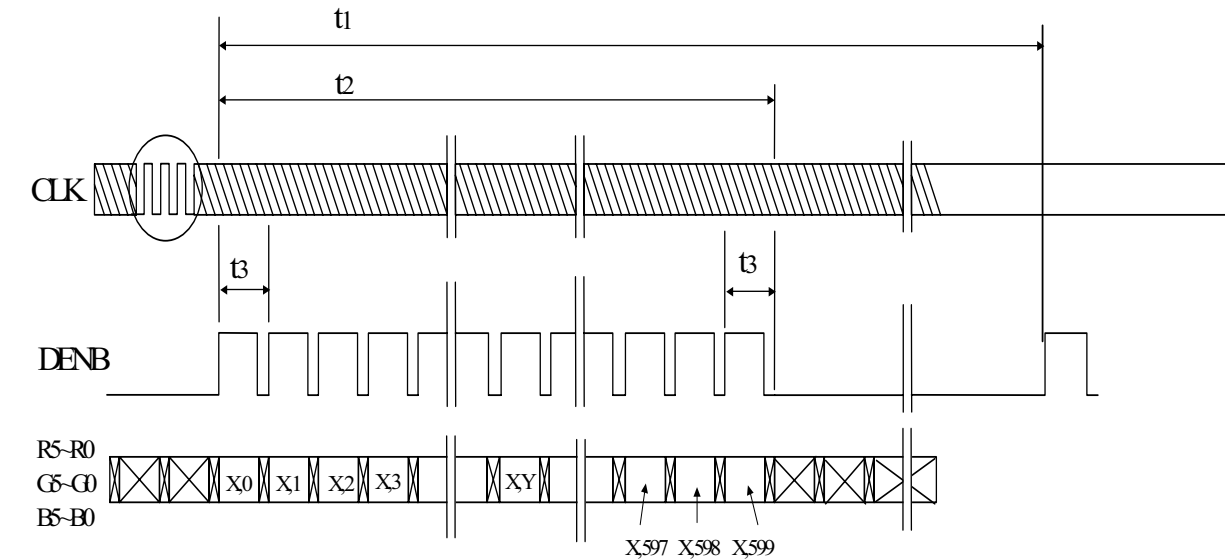

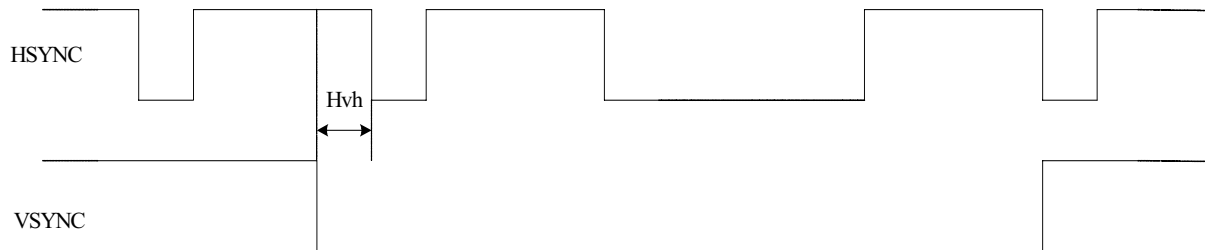
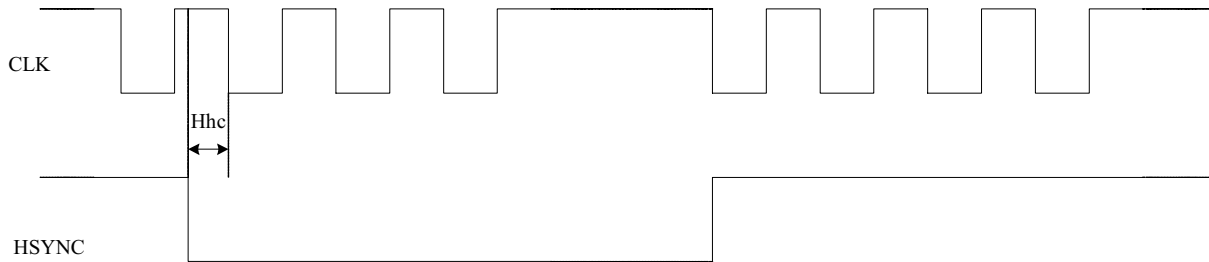
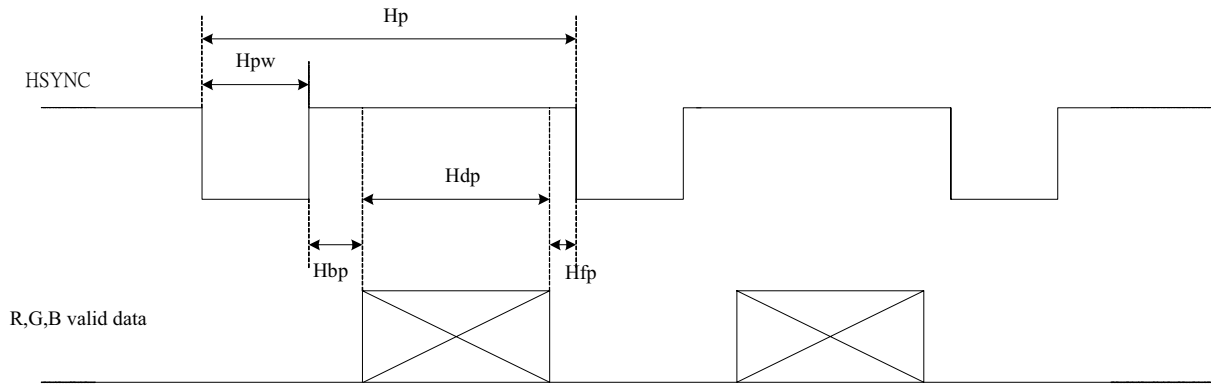

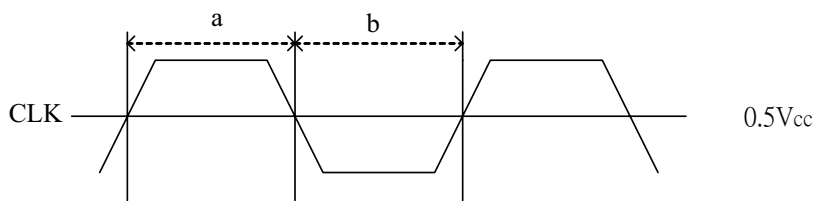
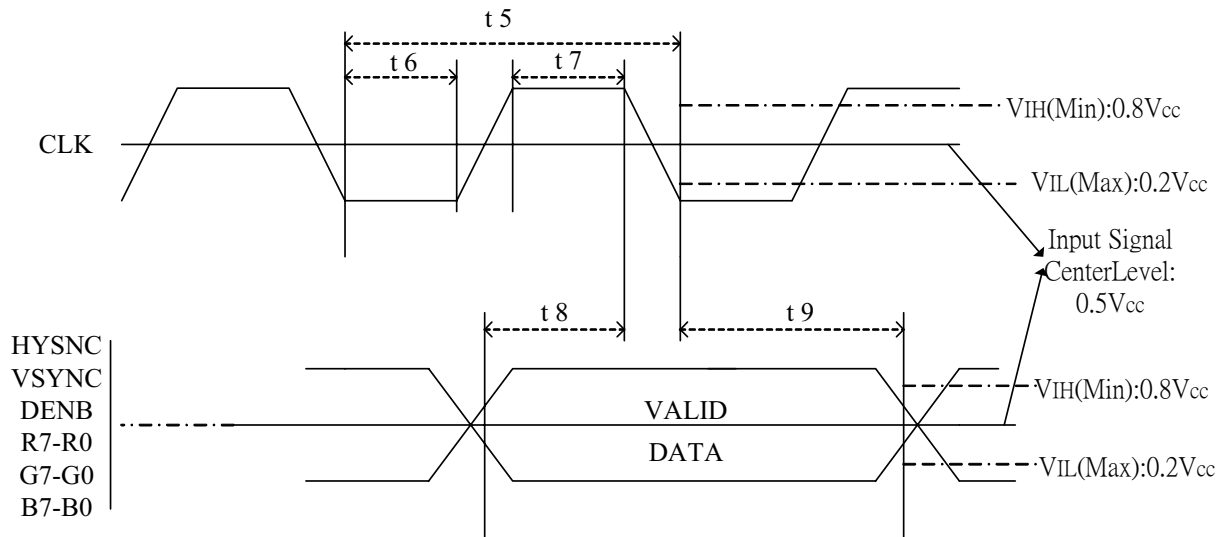
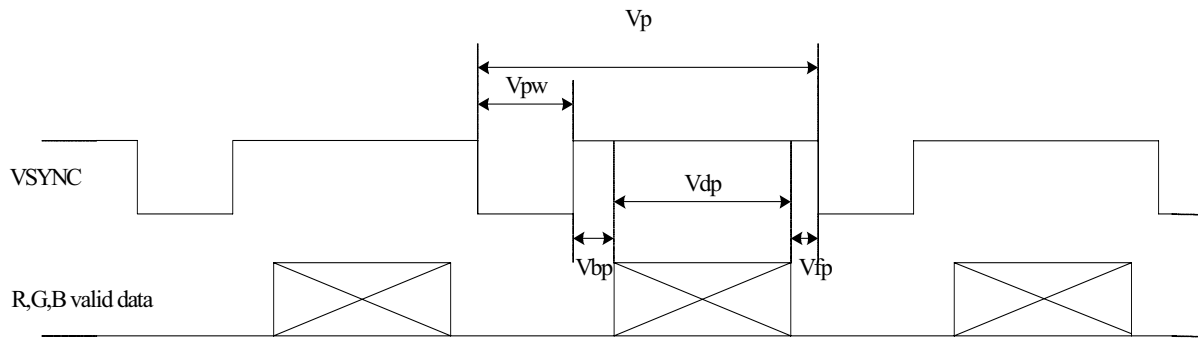

Duty (a , b) : $50 \pm 10\%$

11. Power On Sequence

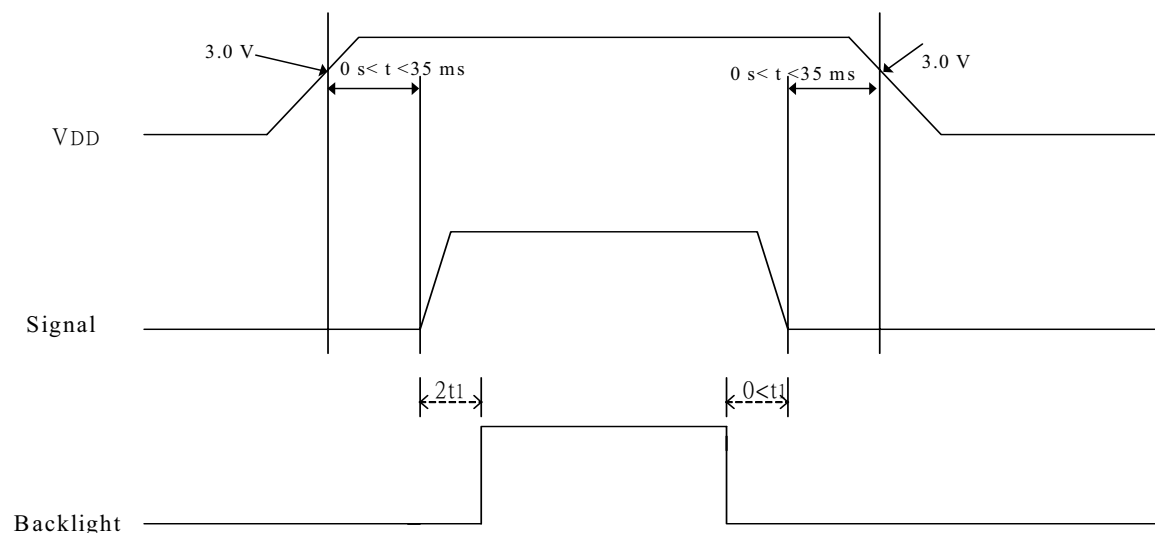

1. The supply voltage for input signals should be same as V_{DD} .
2. When the power is off, please keep whole signals (Hsync, Vsync, DENB, CLK, Data) low level or high impedance.

12. Optical Characteristics

12-1) Specification:

 $T_a = 25^\circ\text{C}$

Parameter		Symbol	Condition	MIN.	TYP.	MAX.	Unit	Remarks
Viewing Angle	Horizontal	θ	$CR \geq 10$	55	60	-	deg	Note 12-1
	Vertical	θ (to 12 o'clock)		40	45	-	deg	
		θ (to 6 o'clock)		55	60	-	deg	
Contrast Ratio		CR	Optimum direction	200	400	-	-	Note 12-2
Luminance		L	$\theta = 0^\circ / \varphi = 0^\circ$	390	420	-	cd/m^2	Note 12-3
LED Life Time		-	25°C	20000	30000	-	hrs	Note 12-4
Response time	Rise	Tr	$\theta = 0^\circ$	-	15	30	ms	Note 12-5
	Fall	Tf	$\varphi = 0^\circ$	-	25	50	ms	
Uniformity		U	-	75	80	-	%	Note 12-6
White Chromaticity		x	$\theta = 0^\circ / \varphi = 0^\circ$	0.28	0.32	0.36	-	
		y	$\theta = 0^\circ / \varphi = 0^\circ$	0.31	0.35	0.39	-	
Cross Talk Ratio		CTK	-	-	-	3.5	%	Note 12-7

The optical characteristics shall be measured in dark room (ambient illumination on panel surface less than 1 Lux). The measuring configuration shows as following figure.

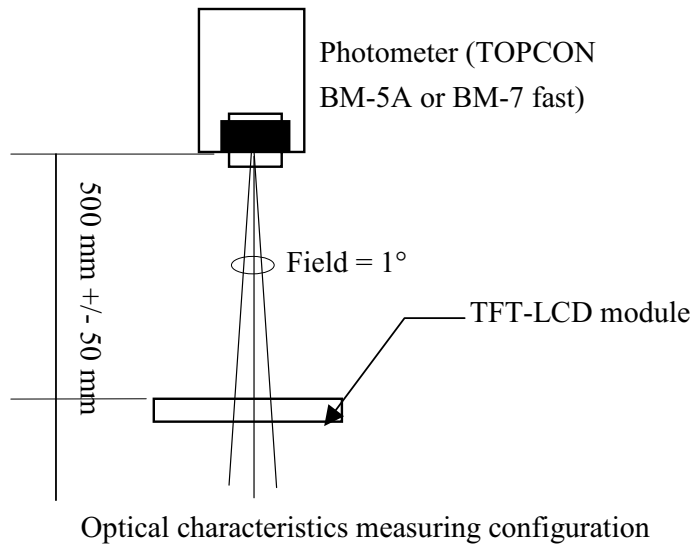

Note 12-1 : The definitions of viewing angles are as follows.

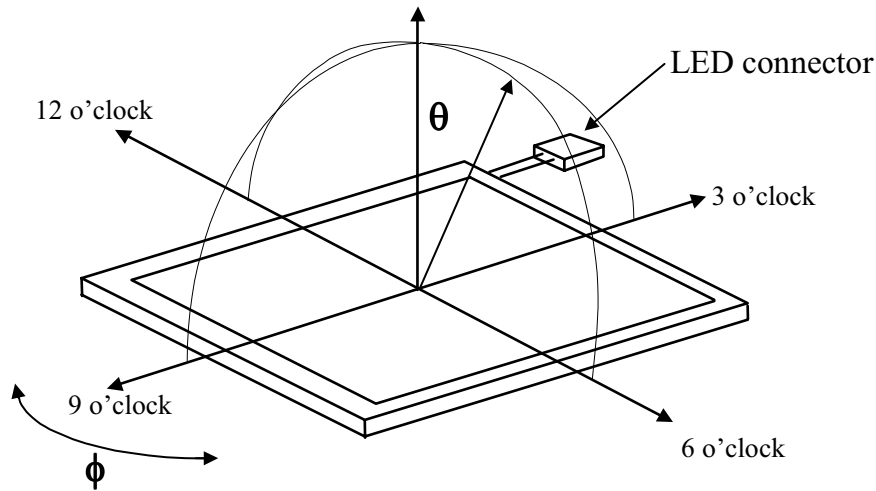

Note 12-2 : The definition of contrast ratio $CR = \frac{\text{Luminance at gray level 63}}{\text{Luminance at gray level 0}}$

Note 12-3 : Topcon BM-5A or BM-7 fast luminance meter 1° field of view is used in the testing

Note 12-4: The “LED Life time “ is defined as the module brightness decrease to 50% original brightness that the ambient temperature is 25°C and $I_{LED} = 20\text{mA}$.

Note 12-5: Definition of Response Time Tr and Tf:

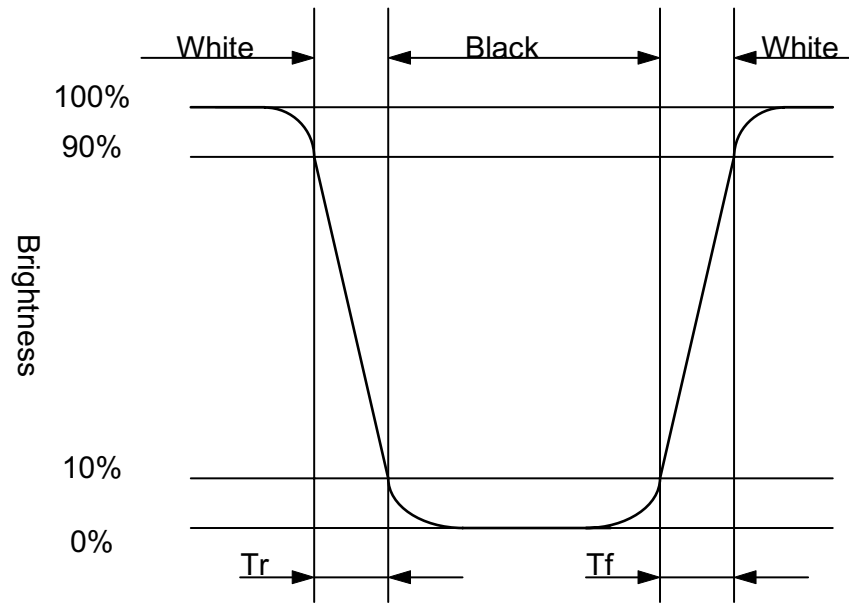

Note 12-6: The uniformity of LCD is defined as

$$U = \frac{\text{The Minimum Brightness of the 9 testing Points}}{\text{The Maximum Brightness of the 9 testing Points}}$$

Luminance meter : BM-5A or BM-7 fast(TOPCON)

Measurement distance : 500 mm +/- 50 mm

Ambient illumination : < 1 Lux

Measuring direction : Perpendicular to the surface of module

The test pattern is white.

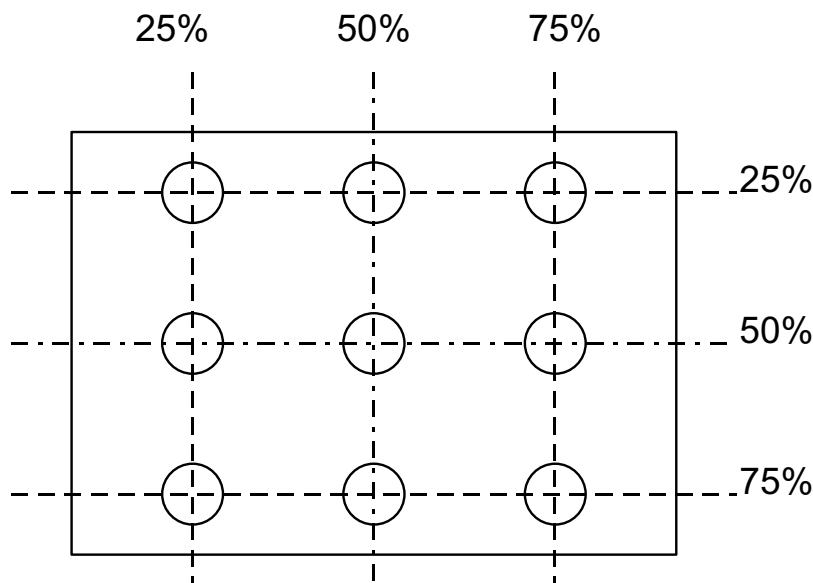

Note 12-7: Cross Talk (CTK) = $\frac{|Y_A - Y_B|}{Y_A} \times 100\%$

Y_A: Brightness of Pattern A

Y_B: Brightness of Pattern B

Luminance meter : BM 5A (TOPCON)

Measurement distance : 500 mm +/- 50 mm

Ambient illumination : < 1 Lux

Measuring direction : Perpendicular to the surface of module

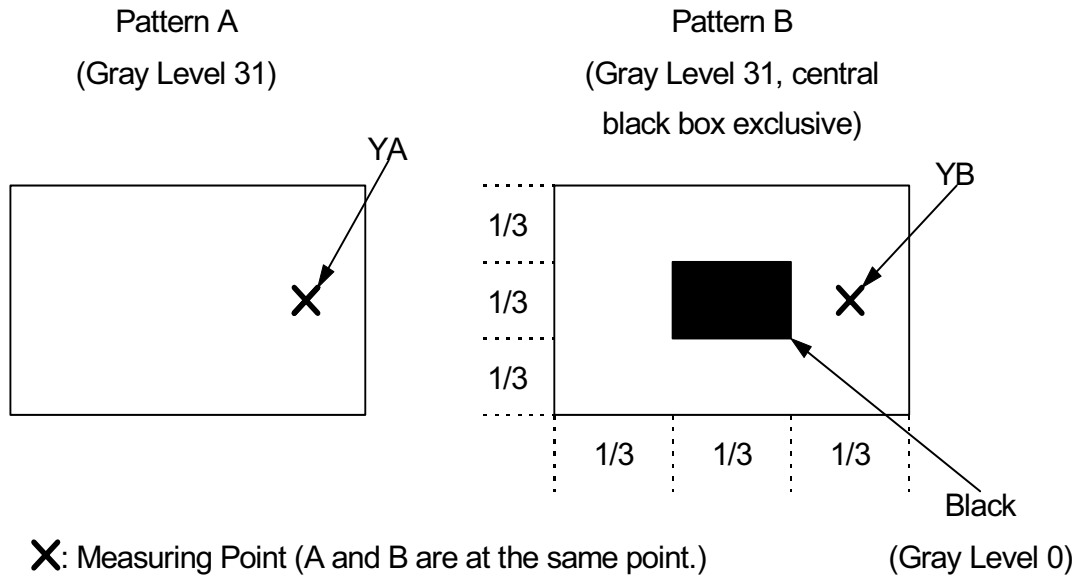

13. Handling Cautions

13-1) Mounting of module

- a) Please power off the module when you connect the input/output connector.
- b) Polarizer which is made of soft material and susceptible to flaw must be handled carefully.
- c) Protective film (Laminator) is applied on surface to protect it against scratches and diets.
- d) Please following the tear off direction as figure13-1 to remove the protective film as slowly as possible, so that electrostatic charge can be minimized.

13-2) Precautions in mounting

- a) When metal part of the TFT-LCD module (shielding lid and rear case) is soiled, wipe it with soft dry cloth.
- b) Wipe off water drops or finger grease immediately. Long contact with water may cause discoloration or spots.
- c) TFT-LCD module uses glass, which breaks or cracks easily if dropped or bumped on hard surface. Please handle with care.
- d) Since CMOS LSI is used in the module. So take care of static electricity and earth yourself when handling.

13-3) Adjusting module

- a) Adjusting volumes on the rear face of the module have been set optimally before shipment.
- b) Therefore, do not change any adjusted values. If adjusted values are changed, the specifications described may not be satisfied.

13-4) Others

- a) Do not expose the module to direct sunlight or intensive ultraviolet rays for many hours.
- b) Store the module at a room temperature place.
- c) The voltage of beginning electric discharge may over the normal voltage because of leakage current from approach conductor by to draw lump read lead line around.
- d) If LCD panel breaks, it is possibly that the liquid crystal escapes from the panel. Avoid putting it into eyes or mouth. When liquid crystal sticks on hands, clothes or feet. Wash it out immediately with soap.
- e) Observe all other precautionary requirements in handling general electronic components.
- f) Please adjust the voltage of common electrode as material of attachment by 1 module.

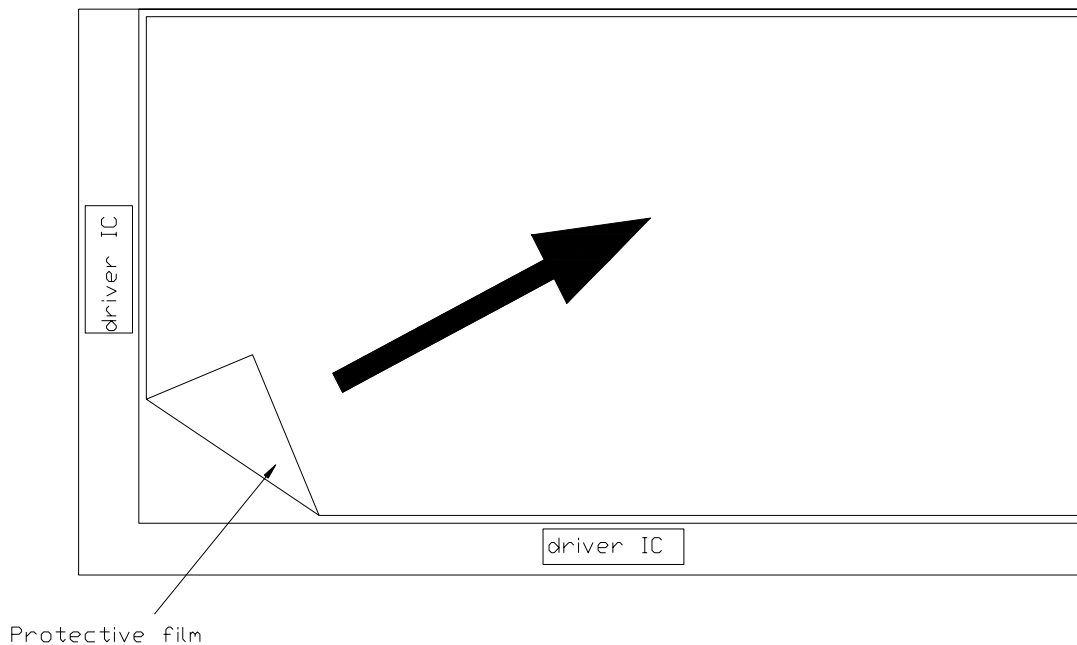

Figure 13 -1 the way to peel off protective film

14. Reliability Test

No	Test Item	Test Condition
1	High Temperature Storage Test	Ta = +80°C, 240 hrs
2	Low Temperature Storage Test	Ta = -25°C, 240 hrs
3	High Temperature Operation Test	Ta = +80°C, 240 hrs
4	Low Temperature Operation Test	Ta = -25°C, 240 hrs
5	High Temperature & High Humidity Operation Test	Ta = +60°C, 90%RH, 240 hrs
6	Thermal Cycling Test (non-operating)	-20°C ← → +80°C, 100 Cycles 30 min 30 min
7	Vibration Test (non-operating)	Frequency : 10 ~ 57 Hz, Amplitude : 0.15 mm 58~500Hz, 1G Sweep time : 11 min ; Test Period : 3 hrs (1 hr for each direction of X, Y, Z)
8	Shock Test (non-operating)	80G, 6ms, X, Y, Z 1 times for each direction
9	Electron Static Discharge	C=150pF, R=330Ω Contact=±8KV, Air=±15KV 10 times/terminal

Ta: ambient temperature

Note: The protective film must be removed before temperature test

[Criteria]

In the standard conditions, there is not display function NG issue occurred. (Including: line defect, no image). All the cosmetic specification is judged before the reliability stress.

15.Packing

ZONE	REV.	DOCUMENT NO.	DESCRIPTION	DATE	REV.BY																									
<p>NOTE: 1.Q'TY: 20 pcs panel/carton. 2.Dimension: 530*295*230mm 3.Weight: 10.00 Kg</p>																														
		<table border="1" style="width:100%; border-collapse: collapse;"> <thead> <tr> <th>ITEM</th> <th>PART NO.</th> <th>DESCRIPTION</th> <th>QTY</th> <th>REMARK</th> </tr> </thead> <tbody> <tr> <td>4</td> <td>50-0100111</td> <td>CARTON</td> <td>1</td> <td></td> </tr> <tr> <td>3</td> <td>50-0500281</td> <td>抗靜電袋</td> <td>20</td> <td>抗靜電</td> </tr> <tr> <td>2</td> <td></td> <td>PD080SL3</td> <td>20</td> <td></td> </tr> <tr> <td>1</td> <td>50-0301691</td> <td>瓦楞隔板緩衝材</td> <td>1</td> <td>上蓋+ 底座</td> </tr> </tbody> </table>		ITEM	PART NO.	DESCRIPTION	QTY	REMARK	4	50-0100111	CARTON	1		3	50-0500281	抗靜電袋	20	抗靜電	2		PD080SL3	20		1	50-0301691	瓦楞隔板緩衝材	1	上蓋+ 底座		
ITEM	PART NO.	DESCRIPTION	QTY	REMARK																										
4	50-0100111	CARTON	1																											
3	50-0500281	抗靜電袋	20	抗靜電																										
2		PD080SL3	20																											
1	50-0301691	瓦楞隔板緩衝材	1	上蓋+ 底座																										
MTL.SPEC.		UNSPECIFIED TOL'S ANGLE ROUGHNESS		REMARK																										
APPROVE	Franks	'07.12.09	SCALE	UNIT	SHEET 1 OF 1																									
CHECK	Franks	'07.12.09			DWG.TITLE PD080SL3 Packing Draw																									
DRAWN	Ethanc	'07.12.09	MTL.NO.		DWG FILE: REV. 01 A4 SIZE																									

元太科技工業股份有限公司
Prime View International Co., Ltd.