



Obsolescence Notice

This product is obsolete.

This information is available for your convenience only.

For more information on Zarlink's obsolete products and replacement product lists, please visit

http://products.zarlink.com/obsolete_products/

Distinctive Characteristics

- ◆ Highly integrated central switch controller
- ◆ State of the art 0.35 micron 3.3 Volt CMOS process
- ◆ 256-PIN PQFP package
- ◆ Operating frequency
 - ◇ -40 40 MHz maximum
 - ◇ -50 50 MHz maximum
 - ◇ -66 66 MHz maximum
- ◆ 16-bit external CAM interface
 - ◇ Supports 1/8 to 16k MAC addresses
- ◆ 32-bit Control Buffer Memory interface
 - ◇ Supports 128k to 1M bytes
 - ◇ Utilize high performance 32-bit Synchronous Burst SRAM
- ◆ Hardware assisted Buffer and Queue Management to minimize CPU overhead
- ◆ 32-bit Management Bus I/O interface
 - ◇ Allows host to access CAM and Control Buffer Memory
 - ◇ Supports Big and Little Endian CPUs
 - ◇ Direct interface with various different standard microprocessors including 386, 486 families and Motorola MPC series embedded processors
- ◆ 32-bit *XpressFlow Bus* Interface
 - ◇ Switching bandwidth
 - 1.28 Gbps @ 40 MHz system clock
 - 1.60 Gbps @ 50 MHz system clock
 - 2.10 Gbps @ 66.67 MHz system clock
 - ◇ Supports up to 8 Multi-port Network Access Controllers
 - ◇ *XpressFlow Bus* access arbitration
 - ◇ *XpressFlow Bus* data transfer load regulation
- ◆ Full IP Switching
 - ◇ Addresses resolved by SC220
- ◆ MAC Address Mapping Table
 - ◇ Supports either CAM based or SRAM based Switching data base

SC220 – XpressFlow Engine

XpressFlow 2020 Ethernet Routing Switch Chipset

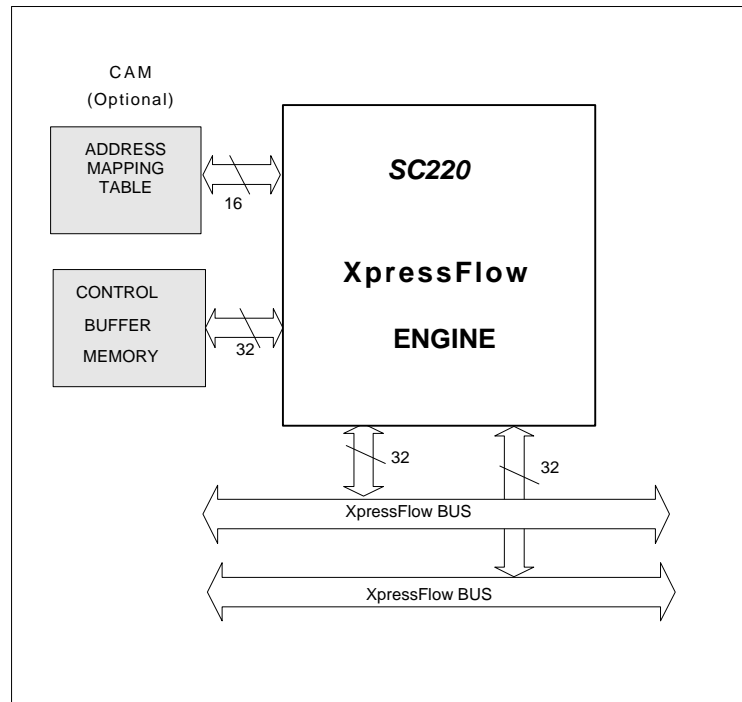

SC220 - XpressFlow Engine

General Description

The *XpressFlow Engine* contains the switching data base interface and buffer management logic in order to do the switching decision making for unicast, multicast, and broadcast frames. Hardware assisted queue manager is incorporated to facilitate buffer management. It also provides a generic Management Bus interface to allow external processor to do initialization, learning, VLAN, and RMON support, etc. In addition, a *XpressFlow Bus* interface block is responsible for communicating with the Network Access Controllers through the *XpressFlow* message passing protocol.

Related Components:

- ◆ EA218E – 8-port 10Mbps Ethernet Access Controller
- ◆ EA218 – 6-port 10 + 2-port 10/100 Ethernet Access Controller
- ◆ EA234 – 4-port 10/100 Fast Ethernet

Characteristics Continue

- ◆ Built-in address to port resolution
 - ◇ Embedded 32-bit HISC™ (High density Instruction Set Core) Processor
 - ◇ Optimized architecture for switch applications
 - ◇ Loadable firmware for easy upgrade
- ◆ Supports unicast, multicast, and broadcast frames
- ◆ Address Filtering
 - ◇ Destination & Source MAC address matching & filtering
- ◆ VLAN classification & verification
 - ◇ Up to 62 groups
 - ◇ Level 1 and 2 mapping
 - ◇ VLAN ID tagging & stripping
 - ◇ Auto padding if necessary after stripping
- ◆ Supports Store-&-Forward Frame Forwarding Mode
- ◆ Collects statistics for RMON

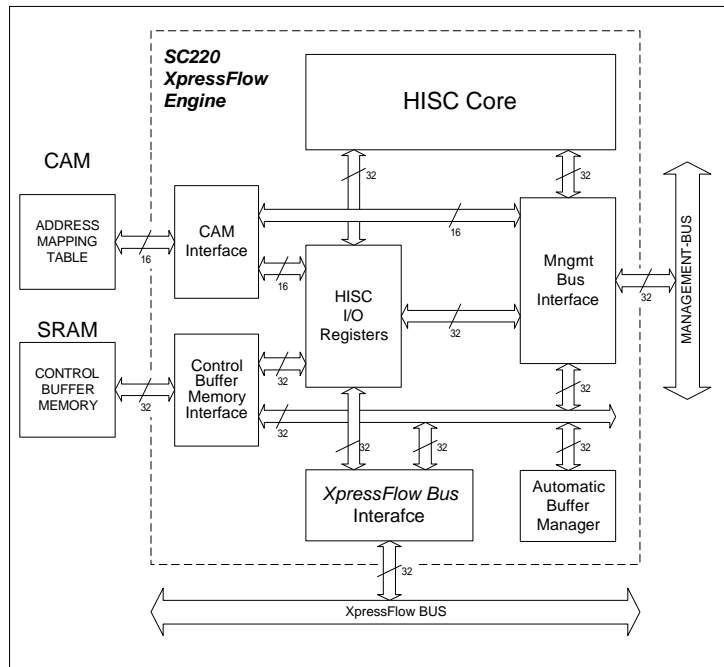

**Block Diagram –
SC220 XpressFlow Engine**

Typical Application:

- ◇ A 16-port Ethernet Switch with 4-Fast Ethernet

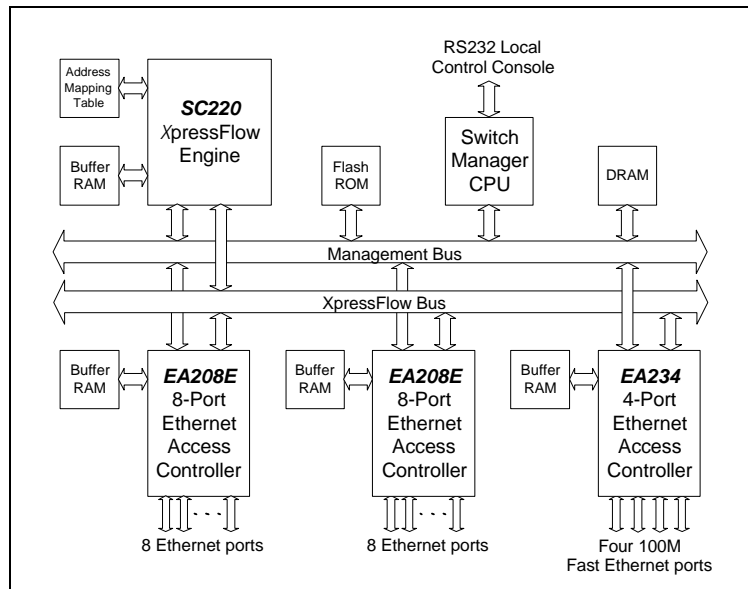

**System Block Diagram --
16-Port Ethernet Switch with 4 Fast Ethernet Up-Links**

1. PIN ASSIGNMENT

1.1 Logic Symbol

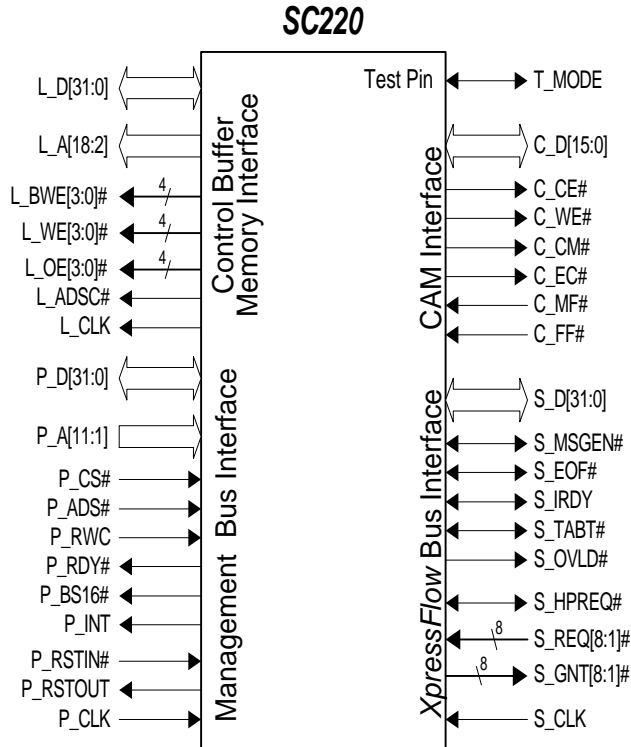

Note: The SC220 is pin compatible to the SC201 with only one exception:

The RSTOUT pin of SC201 is defined as a synchronous RESET output pin which follows the RSTIN input and re-synchronous with P_CLK for meeting the 80386 timing requirement.

The RSTOUT pin for SC220 has a totally different function. It is no longer related with the RSTIN input. The RSTOUT is a watchdog output from SC220 to keep track of the active state of the host processor. Host processor needs to access the Keep Alive register periodically to prevent the setting of the RSTOUT output. The RSTOUT output can be use as Reset input to the host processor.

1.2 Pin Assignment (Preliminary)

| | | |
|-------|--------|----------------------------------------------|
| Note: | # | Active low signal |
| | Input | Input signal |
| | I-ST | Input signal with Schmitt-Trigger |
| | Output | Output signal (Tri-State driver) |
| | Out-OD | Output signal with Open-Drain driver |
| | I/O-TS | Input & Output signal with Tri-State driver |
| | I/O-OD | Input & Output signal with Open-Drain driver |
| | 5VT | Input with 5V Tolerance |

| Pin No(s). | Symbol | Type | Name & Functions |
|-------------------------------------------------------------------------------------------------|-----------------------|---------------|----------------------------------------------------------------------------------|
| XpressFlow Bus Interface | | | |
| 122,121,119,118, 116 | S_D[31:27] / P_C[0:4] | CMOS I/O-TS | XpressFlow Bus – Data Bit [31:28] or Processor Interface Configuration Bit [0:4] |
| 114,113,111,109,108, 106,105,104,103,101, 100,98,97,96,95,93,92, 90,89,88,87,85,84,82, 80,79,77 | S_D[26:0] | CMOS I/O-TS | XpressFlow Bus – Data Bit [27:0] |
| 71 | S_MSGEN# | CMOS I/O-TS | XpressFlow Bus – Message Envelope |
| 69 | S_EOF# | CMOS I/O-TS | XpressFlow Bus – End of Frame |
| 72 | S_IRDY | CMOS I/O-TS | XpressFlow Bus – Initiator Ready |
| 70 | S_TABT# | CMOS I/O-OD | XpressFlow Bus – Target Abort |
| 123 | S_HPREQ# | CMOS I/O-OD | XpressFlow Bus – High Priority Request |
| 140,138,135,133,131, 129,126,124 | S_REQ[8:1]# | CMOS Input ** | XpressFlow Bus – Bus Request [8:1] |
| 141,139,137,134,132, 130,128,125 | S_GNT[8:1]# | CMOS Output | XpressFlow Bus – Bus Grant [8:1] |
| 73 | S_OVLD# | CMOS Output | XpressFlow Bus – Bus Overload |
| 75 | S_CLK | CMOS Input | XpressFlow Bus – Clock |

| Pin No(s). | Symbol | Type | Name & Functions |
|---------------------------------------------------------------------------------------------------------------------------------------------------------|-----------------------|---------------------|--------------------------------------------------------------------------|
| XpressFlow Bus Interface | | | |
| 185,184,183,182,180, 179,177,176,175,174, 172,171,169,168,167, 166,164,163,160,159, 157,156,154,153,151, 150,149,148,146,145, 143,142 | P_D[31:0] | TTL I/O-TS (5VT) | Management Bus – Data Bit [31:0] |
| 211,210,208,207,205, 204,203,202,201,199, 198 | P_A[11:1] | TTL Input (5VT) | Management Bus – Address Bit [11:1] |
| 196 | P_ADS# | TTL Input (5VT) | Management Bus – Address Strobe |
| 191 | P_RWC | TTL Input (5VT) | Management Bus – Read/Write Control |
| 183 | P_RDY# | CMOS Out- OD | Management Bus – Data Ready |
| 184 | P_BS16# | CMOS Out- OD | Management Bus – 16 bit Data Bus |
| 185 | P_CS# | TTL Input (5VT) | Management Bus – Chip Select |
| 189 | P_RSTIN# | TTL In-ST (5VT) | System RESET Input |
| 190 | P_RSTOUT | CMOS Output | CPU RESET Output |
| 192 | P_INT | CMOS Output | Management Bus – Interrupt Request |
| 187 | P_CLK | TTL Input (5VT) | CPU Clock |
| Control Buffer Memory Interface | | | |
| 60,59,58,57,56,54,53,51, 50,49,48,47,46,45,43,42, 40,39,38,37,36,34,33,30, 29,27,26,25,24,23,22,21, | L_D[31:0] | TTL I/O-TS | Local Memory Bus – Data Bit [31:0] |
| 8,6,5,3,2,1,256,255,254, 253,251,250,248,247, 246,245,244 | L_A[18:2] | CMOS Output | Local Memory Bus – Address Bit [17:2] |
| 9 | L_A[19] / L_OE[3]# | CMOS Output | Local Memory Bus – Address Bit [19:18] or Memory Read Chip Select [3] |
| 63, 11, 19 | L_OE[2:0]# | CMOS Output | Local Memory Bus- Read Chip Select [2:0] |
| 242, 62, 10, 18 | L_WE[3:0]# | CMOS Output | Local Memory Bus – Write Chip Select [3:0] |
| 12,13,14,15 | L_BWE[3:0]# | CMOS Output | Local Memory Bus – Byte Write Enable [3:0] |
| 16 | L_ADSC# | CMOS Output | Local Memory Bus – Controller Address Status |
| 66 | L_CLK | CMOS Output | Local Memory Bus – Synchronous Clock |

| Pin No(s). | Symbol | Type | Name & Functions |
|-------------------------------------------------------------------------------------------------------------|------------|---------------------|---------------------------------------------------------------------------------------------|
| CAM Interface | | | |
| 214,215,217,218,219, 220,221,222,223,225, 226,228,229,220.221, | C_D[15:0] | TTL I/O-TS (5VT) | CAM Interface – Data Bus bit [15:0] |
| 239 | C_WE# | CMOS Output | CAM Interface – Write Enable |
| 241 | C_CE# | CMOS Output | CAM Interface – Chip Enable |
| 233 | C_EC# | CMOS Output | CAM Interface – Enable Comparison |
| 234 | C_CM# | CMOS Output | CAM Interface – Data/Command Select |
| 236 | C_FF# | TTL Input (5VT) | CAM Interface – Full Flag |
| 237 | C_MF# | TTL Input (5VT) | CAM Interface – Match Flag |
| Test & Reserved Pins | | | |
| 65 | TEST | CMOS I/O-TS | Test Pin – Set Test Mode upon Reset, and provides test status output during test mode |
| 62,63,64,67,242 | n/c | --- | Reserved Pins (5 pins) |
| Power Pins | | | |
| 32,78,115,161,206,243 | VDD (Core) | Input | +3.3 Volt DC Supply for Core Logic (6 pins) |
| 7,20,31,44,55,68,76,86, 94,102,110,120,144, 152,162,170,178,186, 197,216,227,238,252 | VDD | Input | +3.3 Volt DC Supply for I/O Pads (23 pins) |
| 35,81,112,158,209,240 | VSS (Core) | Input | Ground for Core Logic (6 pins) |
| 4,17,28,41,52,61,66,74, 83,91,99,197,117,127, 136,147,155,165,173, 181,188,200,213,224, 235,249 | VSS | Input | Ground for I/O Pads (26 pins) |

1.3 Connection Diagram – 256-PQFP Package (Top View)

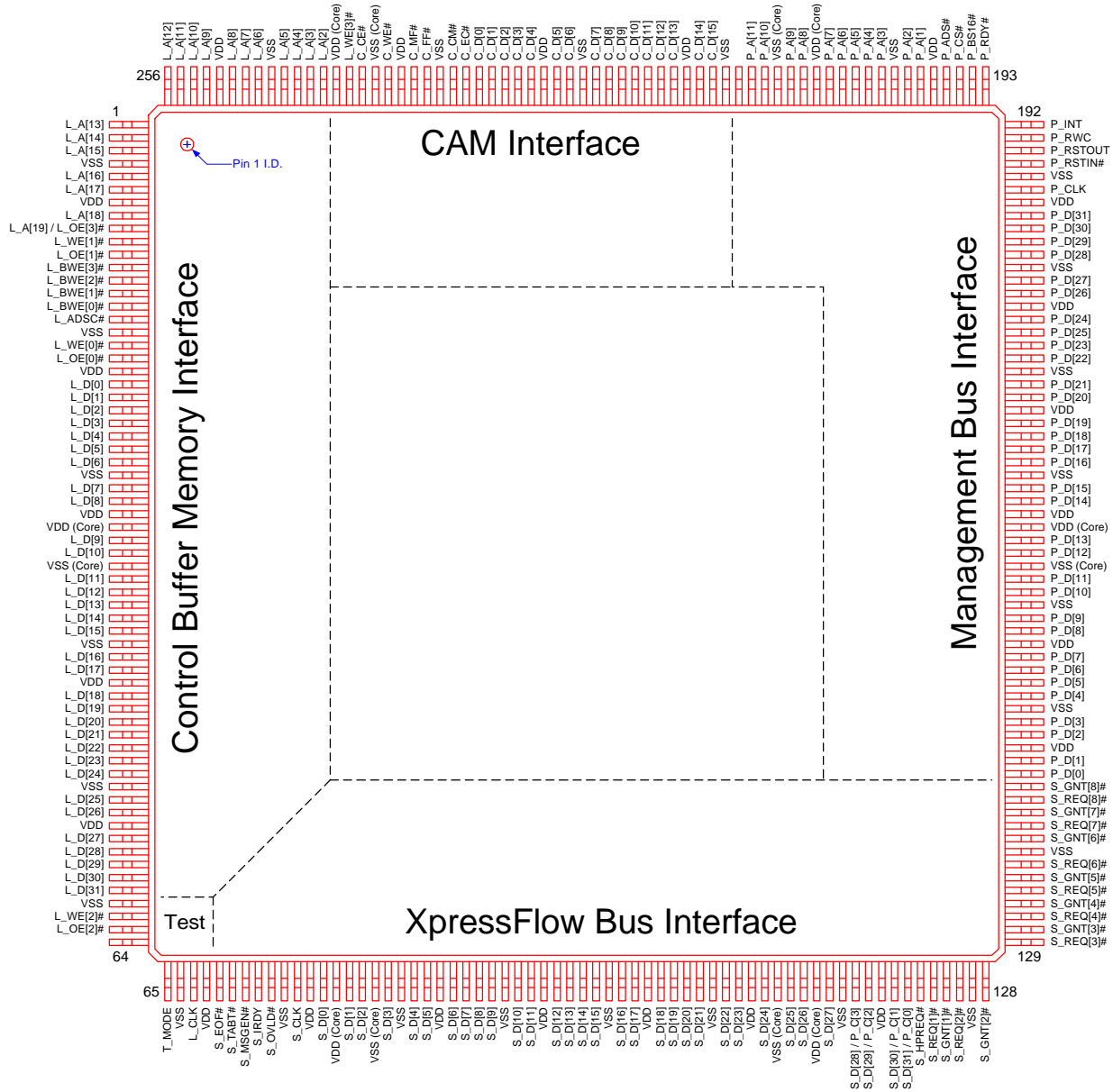

1.4 Connection Diagram – 256-BGA Package (Top View)

| | 1 | 2 | 3 | 4 | 5 | 6 | 7 | 8 | 9 | 10 | 11 | 12 | 13 | 14 | 15 | 16 | 17 | 18 | 19 | 20 |
|---|------------|------------|------------|------------|-----------------|-----------------|----------|---------|----------|------------|----------|----------|----------|----------|------------|------------|------------|------------|------------|------------|
| A | L_A [13] | L_A [12] | L_A [10] | | L_A[5] / P_C[3] | L_A[2] / P_C[0] | | C_ MF# | C_ EC# | C_D [2] | C_D [3] | C_D [6] | C_D [10] | C_D [13] | P_A [11] | P_A [8] | P_A [6] | P_A [3] | P_ BS16# | P_ RDY# |
| B | L_A [14] | | L_A [11] | L_A [8] | L_A [6] | L_A[3] / P_C[1] | C_ CE# | | C_ CM# | C_D [1] | C_D [4] | C_D [7] | C_D [11] | C_D [14] | P_A [10] | P_A [7] | P_A [4] | P_ ADS# | P_A [2] | P_ INT |
| C | L_A [18] | L_A [16] | L_A [15] | L_A [9] | L_A [7] | L_A[4] / P_C[2] | L_WE [3] | C_ WE# | C_ FF# | C_D [0] | C_D [5] | C_D [9] | C_D [12] | C_D [15] | P_A [9] | P_A [5] | P_A [1] | P_ CS# | P_ RWC | P_ RST OUT |
| D | L_OE [1]# | L_OE [3]# | L_A [17] | VDD (Core) | VSS | VDD | VSS | VDD | VSS | VSS | C_D [8] | VDD | VSS | VDD | VDD (Core) | VSS | VDD | P_ RST IN# | | P_ CLK |
| E | L_BWE [2]# | L_BWE [3]# | L_WE [1]# | VSS | | | | | | | | | | | | | VSS | | P_D [31] | P_D [30] |
| F | L_ ADSC# | L_BWE [0]# | L_BWE [1]# | VDD | | | | | | | | | | | | | VDD | P_D [29] | P_D [28] | P_D [27] |
| G | L_D [0] | L_OE [0]# | | VSS | | | | | | | | | | | | | VDD (Core) | P_D [26] | P_D [25] | P_D [24] |
| H | L_D [3] | L_D [2] | L_D [1] | L_WE [0]# | | | | | | | | | | | | | VSS | P_D [23] | P_D [22] | P_D [21] |
| J | L_D [7] | L_D [6] | L_D [4] | L_D [5] | | | | | | | | | | | | | VDD | P_D [20] | P_D [19] | P_D [18] |
| K | L_D [9] | | L_D [8] | VDD | | | | | | | | | | | | | VSS | P_D [17] | P_D [16] | P_D [15] |
| L | L_D [10] | L_D [11] | L_D [12] | VSS | | | | | | | | | | | | | P_D [12] | P_D [13] | | P_D [14] |
| M | L_D [13] | L_D [14] | L_D [15] | VDD (Core) | | | | | | | | | | | | | VSS | P_D [9] | P_D [10] | P_D [11] |
| N | L_D [16] | L_D [17] | L_D [18] | VSS | | | | | | | | | | | | | P_D [3] | P_D [6] | P_D [7] | P_D [8] |
| P | L_D [19] | L_D [20] | L_D [21] | VDD | | | | | | | | | | | | | VDD (Core) | P_D [2] | P_D [4] | P_D [5] |
| R | L_D [22] | L_D [23] | L_D [24] | L_D [26] | | | | | | | | | | | | | VDD | P_D [0] | P_D [1] | |
| T | L_D [25] | L_D [27] | L_D [28] | VSS | | | | | | | | | | | | | VSS | S_REQ [7]# | S_REQ [8]# | S_GNT [8]# |
| U | L_D [29] | L_D [30] | L_D [31] | | VDD | VSS | S_D [4] | VSS | VDD | VDD (Core) | VSS | VDD | VSS | S_D [25] | S_D [29] | S_REQ [1]# | S_GNT [4]# | S_GNT [5]# | S_GNT [6]# | S_GNT [7]# |
| V | | L_WE [2]# | L_ CLK | S_ TABT# | | S_D [0] | S_D [3] | S_D [7] | S_D [10] | S_D [13] | VDD | S_D [20] | S_D [23] | S_D [26] | VDD | S_D [30] | VDD | S_REQ [4]# | S_REQ [5]# | |
| W | L_OE [2]# | S_MSG EN# | S_ EOF# | S_ OVLD# | | S_D [1] | S_D [5] | S_D [8] | S_D [11] | S_D [14] | S_D [17] | S_D [19] | S_D [22] | VSS | S_D [27] | | S_HP REQ# | S_GNT [1]# | S_REQ [6]# | S_GNT [3]# |
| Y | T_ MODE | | S_ IRDY | S_ CLK | | S_D [2] | S_D [6] | S_D [9] | S_D [12] | S_D [15] | S_D [16] | S_D [18] | S_D [21] | S_D [24] | | S_D [28] | S_D [31] | S_REQ [2]# | S_GNT [2]# | S_REQ [3]# |

1.5 Pin Reference Table: (256 Pin PQFP& 256-BGA)

| Pin No. | Signal Name | Pin No. | Signal Name | Pin No. | Signal Name | Pin No. | Signal Name |
|---------|--------------------|---------|-------------|---------|-------------|---------|-----------------|
| 1 | L_A[13] | 65 | TEST | 129 | S_REQ[3]# | 193 | P_RDY# |
| 2 | L_A[14] | 66 | VSS | 130 | S_GNT[3]# | 194 | P_BS16# |
| 3 | L_A[15] | 67 | L_CLK | 131 | S_REQ[4]# | 195 | P_CS# |
| 4 | VSS | 68 | VDD | 132 | S_GNT[4]# | 196 | P_ADS# |
| 5 | L_A[16] | 69 | S_EOF# | 133 | S_REQ[5]# | 197 | VDD |
| 6 | L_A[17] | 70 | S_TABT# | 134 | S_GNT[5]# | 198 | P_A[1] |
| 7 | VDD | 71 | S_MSGEN# | 135 | S_REQ[6]# | 199 | P_A[2] |
| 8 | L_A[18] | 72 | S_IRDY | 136 | VSS | 200 | VSS |
| 9 | L_A[19] / L_OE[3]# | 73 | S_OVLD# | 137 | S_GNT[6]# | 201 | P_A[3] |
| 10 | L_WE[1]# | 74 | VSS | 138 | S_REQ[7]# | 202 | P_A[4] |
| 11 | L_OE[1]# | 75 | S_CLK | 139 | S_GNT[7]# | 203 | P_A[5] |
| 12 | L_BWE[3]# | 76 | VDD | 140 | S_REQ[8]# | 204 | P_A[6] |
| 13 | L_BWE[2]# | 77 | S_D[0] | 141 | S_GNT[8]# | 205 | P_A[7] |
| 14 | L_BWE[1]# | 78 | VDD (Core) | 142 | P_D[0] | 206 | VDD (Core) |
| 15 | L_BWE[0]# | 79 | S_D[1] | 143 | P_D[1] | 207 | P_A[8] |
| 16 | L_ADSC# | 80 | S_D[2] | 144 | VDD | 208 | P_A[9] |
| 17 | VSS | 81 | VSS (Core) | 145 | P_D[2] | 209 | VSS (Core) |
| 18 | L_WE[0]# | 82 | S_D[3] | 146 | P_D[3] | 210 | P_A[10] |
| 19 | L_OE[0]# | 83 | VSS | 147 | VSS | 211 | P_A[11] |
| 20 | VDD | 84 | S_D[4] | 148 | P_D[4] | 212 | |
| 21 | L_D[0] | 85 | S_D[5] | 149 | P_D[5] | 213 | VSS |
| 22 | L_D[1] | 86 | VDD | 150 | P_D[6] | 214 | C_D[15] |
| 23 | L_D[2] | 87 | S_D[6] | 151 | P_D[7] | 215 | C_D[14] |
| 24 | L_D[3] | 88 | S_D[7] | 152 | VDD | 216 | VDD |
| 25 | L_D[4] | 89 | S_D[8] | 153 | P_D[8] | 217 | C_D[13] |
| 26 | L_D[5] | 90 | S_D[9] | 154 | P_D[9] | 218 | C_D[12] |
| 27 | L_D[6] | 91 | VSS | 155 | VSS | 219 | C_D[11] |
| 28 | VSS | 92 | S_D[10] | 156 | P_D[10] | 220 | C_D[10] |
| 29 | L_D[7] | 93 | S_D[11] | 157 | P_D[11] | 221 | C_D[9] |
| 30 | L_D[8] | 94 | VDD | 158 | VSS (Core) | 222 | C_D[8] |
| 31 | VDD | 95 | S_D[12] | 159 | P_D[12] | 223 | C_D[7] |
| 32 | VDD (Core) | 96 | S_D[13] | 160 | P_D[13] | 224 | VSS |
| 33 | L_D[9] | 97 | S_D[14] | 161 | VDD (Core) | 225 | C_D[6] |
| 34 | L_D[10] | 98 | S_D[15] | 162 | VDD | 226 | C_D[5] |
| 35 | VSS (Core) | 99 | VSS | 163 | P_D[14] | 227 | VDD |
| 36 | L_D[11] | 100 | S_D[16] | 164 | P_D[15] | 228 | C_D[4] |
| 37 | L_D[12] | 101 | S_D[17] | 165 | VSS | 229 | C_D[3] |
| 38 | L_D[13] | 102 | VDD | 166 | P_D[16] | 230 | C_D[2] |
| 39 | L_D[14] | 103 | S_D[18] | 167 | P_D[17] | 231 | C_D[1] |
| 40 | L_D[15] | 104 | S_D[19] | 168 | P_D[18] | 232 | C_D[0] |
| 41 | VSS | 105 | S_D[20] | 169 | P_D[19] | 233 | C_EC# |
| 42 | L_D[16] | 106 | S_D[21] | 170 | VDD | 234 | C_CM# |
| 43 | L_D[17] | 107 | VSS | 171 | P_D[20] | 235 | VSS |
| 44 | VDD | 108 | S_D[22] | 172 | P_D[21] | 236 | C_FF# |
| 45 | L_D[18] | 109 | S_D[23] | 173 | VSS | 237 | C_MF# |
| 46 | L_D[19] | 110 | VDD | 174 | P_D[22] | 238 | VDD |
| 47 | L_D[20] | 111 | S_D[24] | 175 | P_D[23] | 239 | C_WE# |
| 48 | L_D[21] | 112 | VSS (Core) | 176 | P_D[24] | 240 | VSS (Core) |
| 49 | L_D[22] | 113 | S_D[25] | 177 | P_D[25] | 241 | C_CE# |
| 50 | L_D[23] | 114 | S_D[26] | 178 | VDD | 242 | L_WE[3] |
| 51 | L_D[24] | 115 | VDD (Core) | 179 | P_D[26] | 243 | VDD (Core) |
| 52 | VSS | 116 | S_D[27] | 180 | P_D[27] | 244 | L_A[2] / P_C[0] |
| 53 | L_D[25] | 117 | VSS | 181 | VSS | 245 | L_A[3] / P_C[1] |
| 54 | L_D[26] | 118 | S_D[28] | 182 | P_D[28] | 246 | L_A[4] / P_C[2] |
| 55 | VDD | 119 | S_D[29] | 183 | P_D[29] | 247 | L_A[5] / P_C[3] |
| 56 | L_D[27] | 120 | VDD | 184 | P_D[30] | 248 | L_A[6] |
| 57 | L_D[28] | 121 | S_D[30] | 185 | P_D[31] | 249 | VSS |
| 58 | L_D[29] | 122 | S_D[31] | 186 | VDD | 250 | L_A[7] |
| 59 | L_D[30] | 123 | S_HPREQ# | 187 | P_CLK | 251 | L_A[8] |
| 60 | L_D[31] | 124 | S_REQ[1]# | 188 | VSS | 252 | VDD |
| 61 | VSS | 125 | S_GNT[1]# | 189 | P_RSTIN# | 253 | L_A[9] |
| 62 | L_WE[2]# | 126 | S_REQ[2]# | 190 | P_RSTOUT | 254 | L_A[10] |
| 63 | L_OE[2]# | 127 | VSS | 191 | P_RWC | 255 | L_A[11] |
| 64 | | 128 | S_GNT[2]# | 192 | P_INT | 256 | L_A[12] |

- Note:**
- ① For 256-BGA package: F4, K4, P4, U5, U9, U12, V11, V15, V17, R17, J17, F17, D17, D14, D12, D8 and D6 are VDD.
 - ② For 256-BGA package: D4, M4, U10, P17, G17 and D15 are VDD(Core).
 - ③ For 256-BGA package: E4, G4, L4, N4, T4, U6, U8, U11, U13, W14, T17, M17, K17, H17, E17, D16, D13, D10, D9, D7, and D5 are VSS.

2 FUNCTIONAL DESCRIPTION

2.1 CAM Interface

- ◆ Direct interface with MUSIC MU9C1480 1k x 64 bit Content Addressable Memory (CAM)
 - ◇ Expandable to support 8k MAC Addresses
- ◆ Two access masters: HISC in XpressFlow Engine, and Switch Manager CPU
- ◆ Master interface with CAM Interface logic via two dedicated CAM Command Blocks
 - ◇ One for HISC
 - ◇ One for Switch Manager CPU
- ◆ Both HISC and Switch Manager CPU can access the CAM by setting up their corresponding CAM Command Blocks, and read the return information from their own Response Data Block

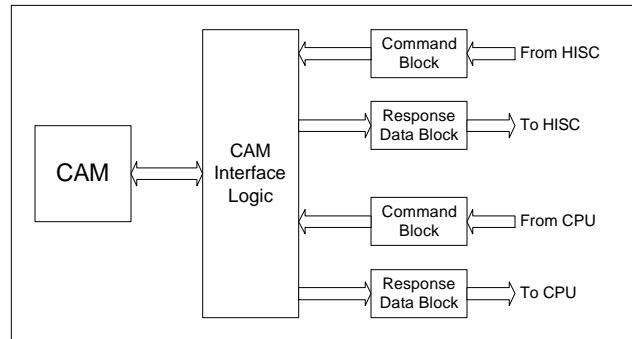

Block Diagram – CAM Interface

2.1.1 Pin Description

| Symbol | Type | Name & Functions |
|-----------|-------------|-------------------------------------------------------------------------------------------------------------------------------------------------------------------------------------------|
| C_D[15:0] | TTL I/O-TS | CAM Data Bus bit [15:0] – a 16-bit data bus for Data/Command input/output. |
| C_CE# | CMOS Output | CAM Chip Enable – Enables the CAM by registers the control signals on its falling edge and release them on its rising edge. Also used for locking and unlocking the cascaded daisy chain. |
| C_WE# | CMOS Output | CAM Write Enable – allows to write data or command to CAM |
| C_CM# | CMOS Output | CAM Data/Command Select – defines data or command operations |
| C_EC# | CMOS Output | CAM Enable Comparison – latches and enables the MF and FF outputs during a comparison cycle. |
| C_MF# | TTL Input | CAM Match Flag – indicates a valid match during a comparison cycle. |
| C_FF# | TTL Input | CAM Full Flag – indicates there is no empty location in the CAM. |

2.1.2 Bus Cycle Waveforms

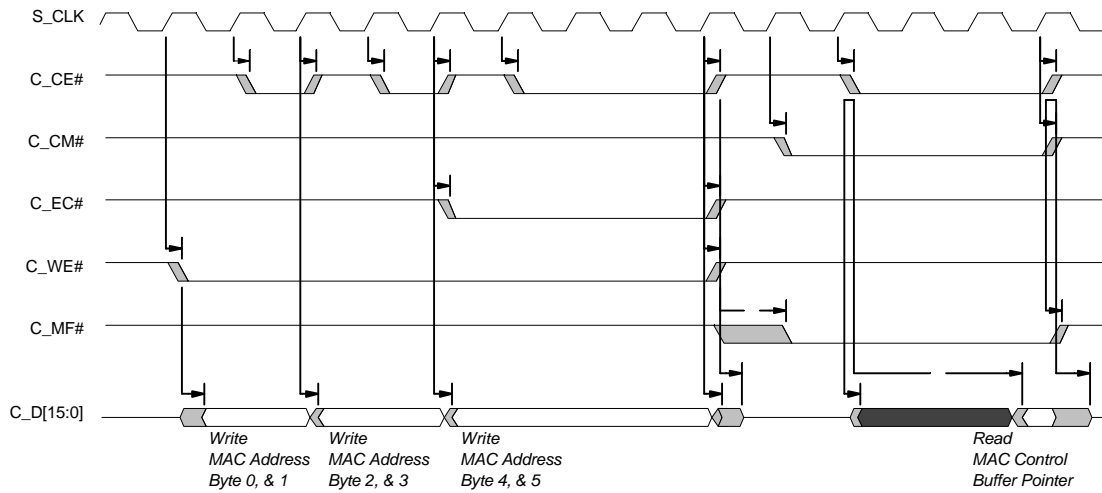

Typical MAC Address Compare Operation

Note: Refer to MUSIC MU9C1480 CAM data sheet for detailed timing parameters.

2.2 Local Memory (Control Buffer Memory) Interface

- ◆ Uses industry standard Synchronous Burst SRAM (Pipe-lined Mode)
 - ◇ Supports 64k x 32, 128k x 32, or 256k x 32 chips up to maximum 2M bytes
- ◆ Provides 4 individual *Byte Write Enable* controls
- ◆ Supports back to back Read or Write operations

2.2.1 Pin Description

| Symbol | Type | Name & Functions |
|-----------------------|----------------|---------------------------------------------------------------------------------------------------------------------------------------------------------------------------------------------------------------------------|
| L_D[31:0] | TTL I/O-TS | <i>Local Memory Data Bus Bit [31:0]</i> – a 32-bit synchronous data bus. |
| L_A[18:2] | CMOS Output | <i>Local Memory Address Bus Bit [18:2]</i> – Bit [17:2] of a synchronous address bus. The memory address is sampled when L_CS# is enabled and L_ADSC# is asserted. |
| L_A[19] / L_WE[3]# | CMOS Output | <i>Local Memory Address Bus Bit [19] or Local Memory Write Chip Select [3]</i> – Depends on memory configuration, this pin can be used as the Local Memory Address Bit [19] or as the Local Memory Write Chip Select [3]. |
| L_WE[2:0]# | CMOS Output | <i>Local Memory Write Chip Select [2:0]</i> – allows up to write one of the 4 banks of memory. |
| L_OE[3:0]# | CMOS Output | <i>Local Memory Read Chip Select [3:0]</i> – allows up to read one of the 4 banks of memory. |
| L_BWE[3:0]# | CMOS Output | <i>Local Memory Byte Write Enable [3:0]</i> – use to write individual bytes. |
| L_ADSC# | CMOS Output | <i>Local Memory Controller Address Status</i> – to load a new address. |
| L_CLK | CMOS Output | <i>Local Memory Clock</i> – a synchronous clock to memory devices. |

Supported Memory Configurations

| RAM Chip Size | # of RAM Chips | Total Buffer Memory Size | Read/Write Chip Select and High Address Bits | | | | | | | |
|---------------|----------------|--------------------------|----------------------------------------------|----------|----------|----------|----------|----------|----------|----------|
| | | | Chip #3 | | Chip #2 | | Chip #1 | | Chip #0 | |
| | | | L_A[19] / L_WE[3]# | L_OE[3]# | L_WE[2]# | L_OE[2]# | L_WE[1]# | L_OE[1]# | L_WE[0]# | L_OE[0]# |
| 64k x 32 | 1 | 256k bytes | ---- | ---- | ---- | ---- | ---- | ---- | L_WE[0]# | L_OE[0]# |
| | 2 | 512k bytes | ---- | ---- | ---- | ---- | L_WE[1]# | L_OE[1]# | L_WE[0]# | L_OE[0]# |
| | 4 | 1M bytes | L_WE[3]# | L_OE[3]# | L_WE[2]# | L_OE[2]# | L_WE[1]# | L_OE[1]# | L_WE[0]# | L_OE[0]# |
| 128k x 32 | 1 | 256k bytes | ---- | ---- | ---- | ---- | ---- | ---- | L_WE[0]# | L_OE[0]# |
| | 2 | 1M bytes | ---- | ---- | ---- | ---- | L_WE[1]# | L_OE[1]# | L_WE[0]# | L_OE[0]# |
| | 4 | 2M bytes | L_WE[3]# | L_OE[3]# | L_WE[2]# | L_OE[2]# | L_WE[1]# | L_OE[1]# | L_WE[0]# | L_OE[0]# |
| 256k x32 | 1 | 1M bytes | L_A[19] | ---- | ---- | ---- | ---- | ---- | L_WE[0]# | L_OE[0]# |
| | 2 | 2M bytes | L_A[19] | ---- | ---- | ---- | L_WE[1]# | L_OE[1]# | L_WE[0]# | L_OE[0]# |

2.2.2 Bus Cycle Waveforms

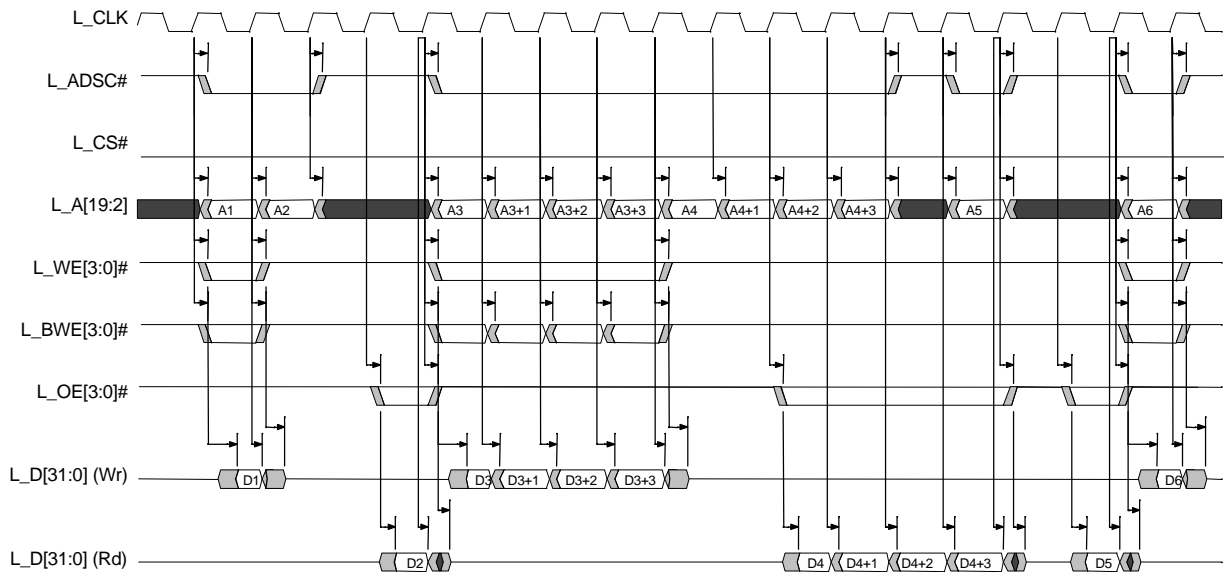

Typical Local Memory Access Operations

Note: Refer to manufacturer’s data sheet for detailed timing parameters.

2.3 Management Bus Interface

- ◆ Supports various industry standard micro-processors including:
 - ◇ Intel 186/486 family or equivalent
 - ◇ Motorola MPC series embedded processors
- ◆ Easily adapts to other industry standard CPUs
- ◆ Provides separate Address and Data bus
- ◆ Supports Big & Little Endian byte ordering
- ◆ Supports 16- or 32-bit Data Bus
- ◆ Provides a single interrupt signal to Switch Manager CPU

2.3.1 Pin Description

| Symbol | Type | Name & Functions | | | | | | | | | | | | | | | | | | | | | | | | |
|-----------|------------------|---------------------------------------------------------------------------------------------------------------------------------------------------------------------------------------------------------------------------------------------------------------------------------------------------------------------------------------------------------------------------------------------------------------------------------------------------------------------------------------------------------------------------------------------------------------------------------------------------------------------------------------------------------------------------------------------------------------------------------------------------------------------------------------------------------------------------------------------------------------------------------------------------------------------------------------------------------------------------------------------------------------------------------------------------------------------------------------------------------------------------------------------------------------------------------------------------------------------------------------------------------------------------------------------------------------------------------------------------------------------------------------------------------------------------------------------------------------------------------------------------------------------------------------------------------------------|--------|-----------|------------|------|------|------|--|-----------|------------|-----|-----------|------------|----|----------|---------------|--------|--------|--------|----|----------|------------|--------|--------|-------|
| P_C[4:0] | CMOS Input | <p><i>Processor Configuration bit [4:0]:</i> – During the Reset Cycle, the P_C[4:0] pins provides the processor configuration. By using external weak pull-up or -down resistors, they define the External Management Bus Interface Configuration. These inputs are sampled at the trailing edge of the Reset cycle.</p> <p>C[0] – Defines the CPU Clock input is 1X or 2X clock C[1] – Selects either Big or Little Endian byte ordering C[2] – Defines the polarity of the P_RWC (Rd/Wr Control) input C[3] – Defines the CPU Data Bus width – 16-bit or 32-bit C[4] – Defines the timing relationship between P_RDY and P_D[15:0] valid. If C[4] is High, the P_D[15:0] are valid along in the same clock period as P_RDY is asserted. If C[4] is Low, the P_RDY is asserted one clock period <u>early</u> ahead of the P_D[15:0] are valid.</p> <table border="1" style="margin-left: 40px;"> <thead> <tr> <th></th> <th>C[0]</th> <th>C[1]</th> <th>C[2]</th> <th>C[3]</th> <th>C[4]</th> </tr> </thead> <tbody> <tr> <td></td> <td>CPU Clock</td> <td>Byte Order</td> <td>RWC</td> <td>Bus Width</td> <td>RDY Timing</td> </tr> <tr> <td>Lo</td> <td>1X Clock</td> <td>Little Endian</td> <td>P_R/W#</td> <td>16-bit</td> <td>Normal</td> </tr> <tr> <td>Hi</td> <td>2x Clock</td> <td>Big Endian</td> <td>P_W/R#</td> <td>32-bit</td> <td>Early</td> </tr> </tbody> </table> <p>After RESET, these pins are used as XpressFlow Bus Data bit [31:27].</p> | | C[0] | C[1] | C[2] | C[3] | C[4] | | CPU Clock | Byte Order | RWC | Bus Width | RDY Timing | Lo | 1X Clock | Little Endian | P_R/W# | 16-bit | Normal | Hi | 2x Clock | Big Endian | P_W/R# | 32-bit | Early |
| | C[0] | C[1] | C[2] | C[3] | C[4] | | | | | | | | | | | | | | | | | | | | | |
| | CPU Clock | Byte Order | RWC | Bus Width | RDY Timing | | | | | | | | | | | | | | | | | | | | | |
| Lo | 1X Clock | Little Endian | P_R/W# | 16-bit | Normal | | | | | | | | | | | | | | | | | | | | | |
| Hi | 2x Clock | Big Endian | P_W/R# | 32-bit | Early | | | | | | | | | | | | | | | | | | | | | |
| P_A[11:1] | TTL In (5VT) | <i>Address Bus Bit [11:1]</i> – I/O port address | | | | | | | | | | | | | | | | | | | | | | | | |
| P_D[15:0] | TTL I/O-TS (5VT) | <i>Data Bus Bit [15:0]</i> – a 16-bit synchronous data bus. | | | | | | | | | | | | | | | | | | | | | | | | |
| P_ADS# | TTL In (5VT) | <i>Address Strobe</i> – indicates valid address is on the bus | | | | | | | | | | | | | | | | | | | | | | | | |
| P_RWC | TTL In-put (5VT) | <p><i>Read/Write Control</i> – indicates the current bus cycle is a read or write cycle. C[1] defines the polarity of this signal during the Reset cycle.</p> <p>C[1]=Low P_R/W# is used for PowerPC or other similar processors. C[1]=High P_W/R# is used for 386, 486 or other similar processors</p> | | | | | | | | | | | | | | | | | | | | | | | | |
| P_RDY# | TTL Out-OD | <i>Data Ready</i> – timing indicates for bus data valid | | | | | | | | | | | | | | | | | | | | | | | | |
| P_BS16# | TTL Out-OD | <i>Bus Size 16</i> – response to bus master that the SC-201 only supports 16-bit data bus width. | | | | | | | | | | | | | | | | | | | | | | | | |
| P_CS# | TTL In (5VT) | <i>Chip Select</i> – indicates the XpressFlow Engine is the target for the current bus operation. | | | | | | | | | | | | | | | | | | | | | | | | |
| P_INT ① | TTL Out-put | <i>Interrupt Request to Switch Manager CPU</i> The polarity of this signal output is programmable via chip configuration register. | | | | | | | | | | | | | | | | | | | | | | | | |
| P_RSTIN# | TTL In-ST (5VT) | <i>Power Up Reset Input</i> – Asynchronous Reset Input from either Power-Up Reset circuit or from Switch Manager CPU (except 386) | | | | | | | | | | | | | | | | | | | | | | | | |
| P_RSTOUT | CMOS Output | <i>Synchronous Reset Output</i> – Synchronous Reset Output for i386 family as the Switch Manager CPU | | | | | | | | | | | | | | | | | | | | | | | | |
| P_CLK | TTL In (5VT) | <i>CPU Clock</i> – 1X Clock for the others | | | | | | | | | | | | | | | | | | | | | | | | |

Note: ① Output signal with programmable polarity.

2.3.2 Motorola MPC801 Processor Interface

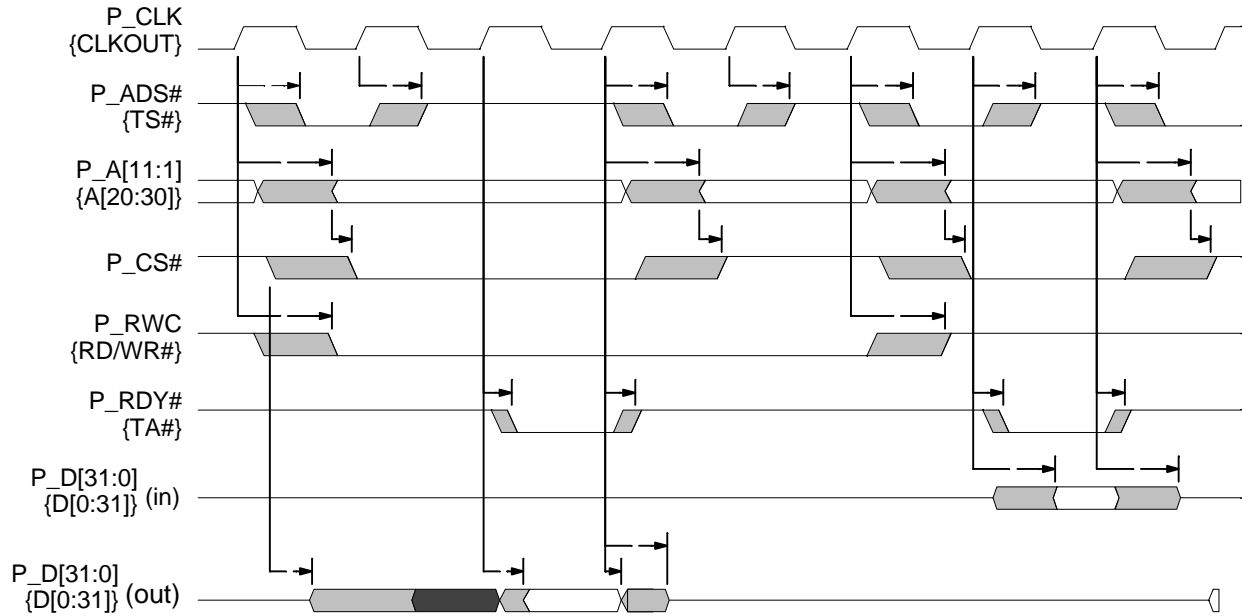

Note: Mnemonics within {} are the equivalent signals defined by MPC801

Typical Motorola MPC801 CPU I/O Access Operations

2.3.3 Intel 486 Processor Interface

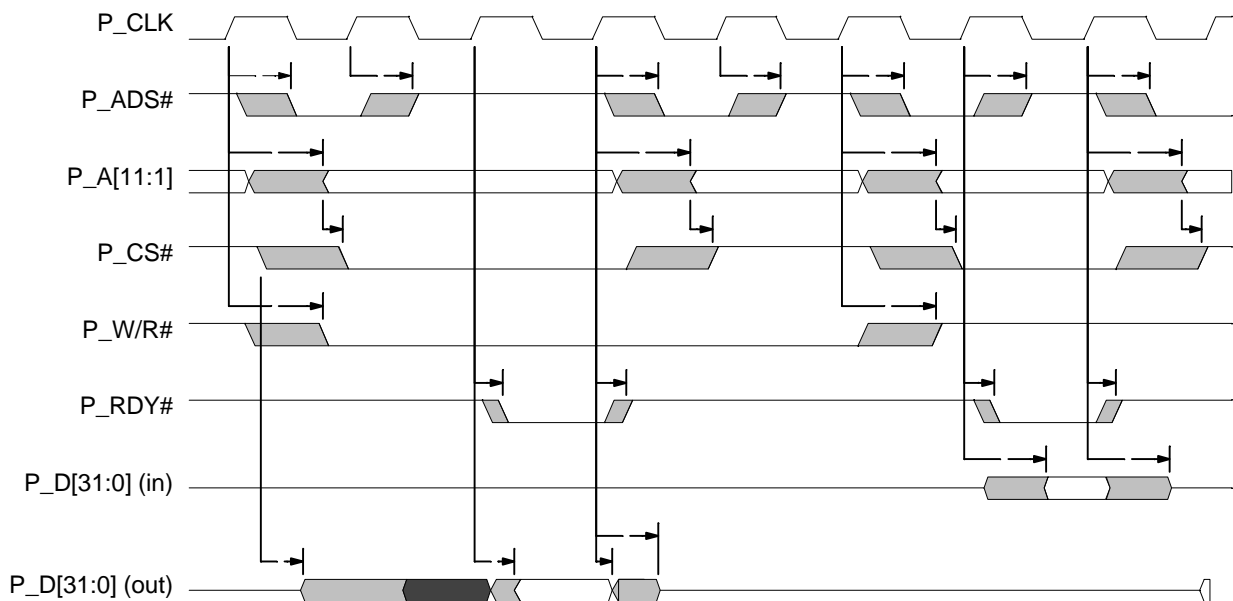

Typical 486 CPU I/O Access Operations

2.3.4 Intel 386 Processor Interface

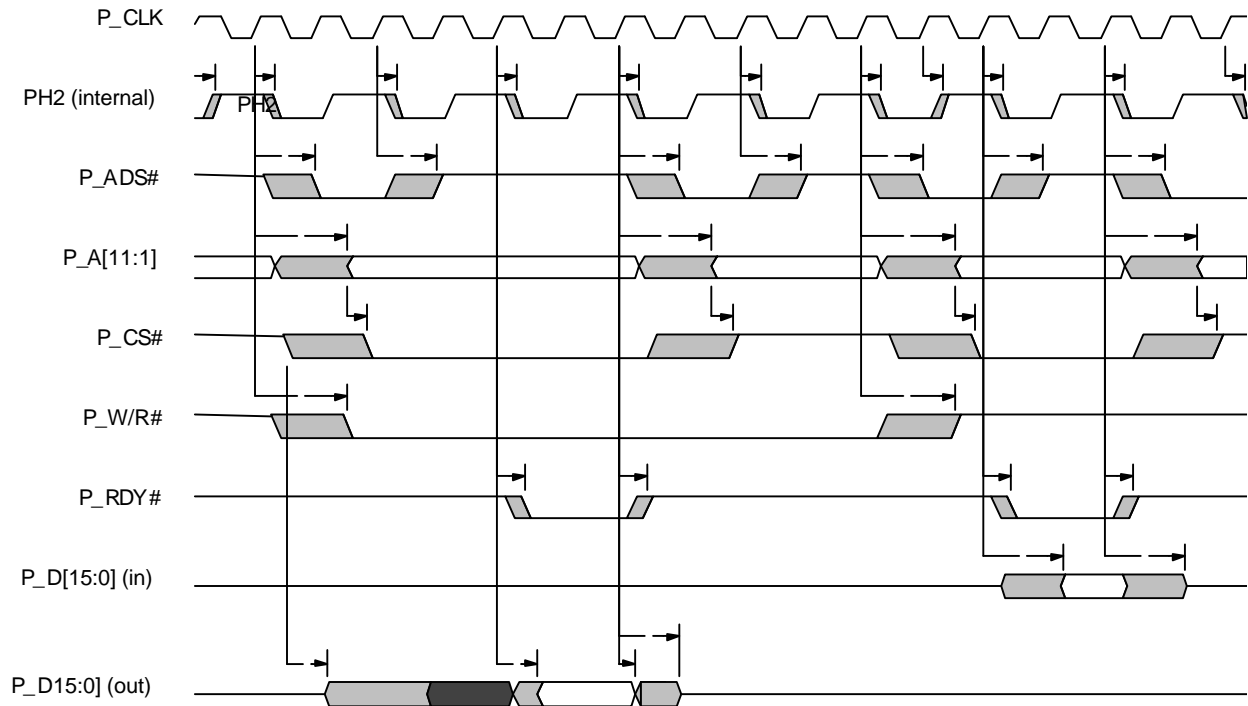

Typical 386 CPU I/O Access Operations

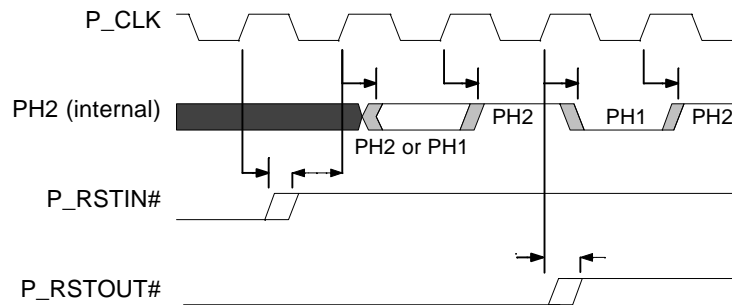

Internal PH2 Clock Synchronization

Note: See Intel 386 Processor Data Book for more details

2.3.5 Register Map

Note: All 32-bit registers are D-word aligned.

All 16-bit registers are also D-word aligned and right justified.

For the Little Endian CPUs, register offset bit [1,0] are always set to be 00.

For the Big Endian CPUs, register offset bit [1,0] are always set to be 10.

This is a Global Register. CPU is allowed to write the Global Register of all devices by a single operation.

These registers are reserved for system diagnostic usage only.

| Register | Description | I/O Offset | | Reg. Size | W/R | Note: |
|---------------------------------------------|------------------------------------------------|---------------|------------|-----------|------|-------|
| | | Little Endian | Big Endian | | | |
| Device Configuration Registers (DCR) | | | | | | |
| GCR | Global Control Register | hF00 | hF02 | 16-bit | W/-- | |
| DCR0 | Device Status Register | hF00 | hF02 | 16-bit | --/R | |
| DCR1 | Signature & Revision Register | hF10 | hF12 | 16-bit | --/R | |
| DCR2 | ID Register | hF20 | hF22 | 16-bit | W/R | |
| DCR3 | Local Control Register | hF30 | hF32 | 16-bit | W/R | |
| DCR4 | Interface Status Register | hF40 | hF42 | 16-bit | --/R | |
| DCR5 | Bus Credit Register | hF50 | hF52 | 16-bit | W/R | |
| Interrupt Controls | | | | | | |
| ISR | Interrupt Status Register – Unmasked | hF80 | hF82 | 16-bit | --/R | |
| ISRM | Interrupt Status Register – Masked | hF90 | hF92 | 16-bit | --/R | |
| IMSK | Interrupt Mask Register | hFA0 | hFA2 | 16-bit | W/R | |
| IAR | Interrupt Acknowledgment Register | hFB0 | hFB2 | 16-bit | W/-- | |
| Buffer Memory Interface | | | | | | |
| MWAR | Memory Write Address Register – Single Cycle | hE08 | hE08 | 32-bit | W/R | |
| MRAR | Memory Read Address Register – Single Cycle | hE18 | hE18 | 32-bit | W/R | |
| MBAR | Memory Address Register – Burst Mode | hE28 | hE28 | 32-bit | W/R | |
| MWBS | Memory Write Burst Size (in D-words) | hE40 | hE42 | 16-bit | W/R | |
| MRBS | Memory Read Burst Size (in D-words) | hE50 | hE52 | 16-bit | W/R | |
| MWDR | Memory Write Data Register | hE68 | hE68 | 32-bit | W/-- | |
| MWDX | Memory Write Data Register – Byte Swapping | hE6C | hE6C | 32-bit | W/-- | |
| MRDR | Memory Read Data Register | hE68 | hE68 | 32-bit | --/R | |
| MRDX | Memory Read Data Register – Byte Swapping | hE6C | hE6C | 32-bit | --/R | |
| Buffers & Stacks Management | | | | | | |
| Frame Control Buffers | | | | | | |
| FCBBA | Frame Control Buffer – Base Address | hD00 | hD02 | 16-bit | W/R | |
| FCBA | Frame Control Buffer – Buffer Allocation | hD20 | hD22 | 16-bit | --/R | |
| FCBR | Frame Control Buffer – Buffer Release | hD20 | hD22 | 16-bit | W/-- | |
| FCBAG | Frame Control Buffer – Buffer Aging Status | hD30 | hD32 | 16-bit | --/R | |
| FCBSA | Frame Ctrl Buffer Stack – Base Address | hD80 | hD82 | 16-bit | W/R | |
| FCBSL | Frame Ctrl Buffer Stack – Size Limit | hD90 | hD92 | 16-bit | W/R | |
| FCBST | Frame Ctrl Buffer Stack – Buffer Low Threshold | hDA0 | hDA2 | 16-bit | W/R | |
| FCBSS | Frame Ctrl Buffer Stack – Allocation Status | hDB0 | hDB2 | 16-bit | --/R | |

| Register | Description | I/O Offset | | Reg. Size | W/R | Note: |
|---------------------------------------------------|-------------------------------------------------|---------------|------------|-----------|------|-------|
| | | Little Endian | Big Endian | | | |
| Buffers & Stacks Management (Continue) | | | | | | |
| Switch Control Buffers | | | | | | |
| SCBBA | Switch Control Buffer – Base Address | hC00 | hC02 | 16-bit | W/R | |
| SCBA | Switch Control Buffer – Buffer Allocation | hC20 | hC22 | 16-bit | --/R | |
| SCBAG | Switch Control Buffer – Buffer Aging Status | hC30 | hC32 | 16-bit | --/R | |
| SCBSA | Switch Ctrl Buffer Stack – Base Address | hC80 | hC82 | 16-bit | W/R | |
| SCBSL | Switch Ctrl Buffer Stack – Size Limit | hC90 | hC92 | 16-bit | W/R | |
| SCBST | Switch Ctrl Buffer Stack – Buffer Low Threshold | hCA0 | hCA2 | 16-bit | W/R | |
| SCBSS | Switch Ctrl Buffer Stack – Allocation Status | hCB0 | hCB2 | 16-bit | --/R | |
| MAC Control Tables | | | | | | |
| MCTA | MAC Control Table – Table Allocation | hB20 | hB22 | 16-bit | --/R | |
| MCTR | MAC Control Table – Table Release | hB20 | hB22 | 16-bit | W/- | |
| MCTSA | MAC Ctrl Table Stack – Base Address | hB80 | hB82 | 16-bit | W/R | |
| MCTSS | MAC Ctrl Table Stack – Allocation Status | hBB0 | hBB2 | 16-bit | --/R | |
| Queue Management | | | | | | |
| QSBA | Queue Structure – Base Address | hA00 | hA02 | 16-bit | W/R | |
| MFTA | Multicast Frame Table – Base Address | hA10 | hA12 | 16-bit | W/R | |
| CINQ | CPU Input Queue | hA88 | hA88 | 32-bit | W/-- | |
| COTQ | CPU Output Queue | hA88 | hA88 | 32-bit | --/R | |
| CSQ0 | CPU Status Queue – 1 st D-word | hA98 | hA98 | 32-bit | --/R | |
| CSQ1 | CPU Status Queue – 2 nd D-word | hAA8 | hAA8 | 32-bit | --/R | |
| CSQ2 | CPU Status Queue – 3 rd D-word | hAB8 | hAB8 | 32-bit | --/R | |
| CAM Interface | | | | | | |
| CCWR | CAM Command/Data Write Register | h908 | h908 | 32-bit | W/-- | |
| CSRL | CAM Status/Data Read Register Low | h928 | h928 | 32-bit | --/R | |
| CSRH | CAM Status/Data Read Register High | h938 | h938 | 32-bit | --/R | |
| HISC Control | | | | | | |
| HPCR | HISC Processor Control Register | h980 | h982 | 16-bit | W/R | |
| HMCL | HISC Micro-Code Loading Port | h998 | h998 | 32-bit | W/R | |
| HPRC | HISC Priority Control Register | h9B0 | h9B2 | 16-bit | W/R | |

2.4 XpressFlow Bus Interface

- ◆ Vertex Networks' optimized XpressFlow Bus architecture
- ◆ Provides 1G bps switching bandwidth
- ◆ Full multi bus master structure
- ◆ Allows XpressFlow Engine to communicate with Access Controllers via a message passing protocol
 - ◇ Command Messages for passing control information between devices
 - ◇ Data Messages for forwarding an Ethernet frame from receiving port to transmission port
- ◆ Built-in intelligent bus load regulator for data traffic balancing
- ◆ Provides centralized bus arbitration with two level request priorities
 - ◇ High priority for Data Messages
 - ◇ Low priority for Command Messages

2.4.1 Pin Description

| Symbol | Type | Name & Functions |
|-------------|-------------|----------------------------------------------------------------------------------------------------------------------------------------------------------------------------------------------------------------------------------------|
| S_D[31:0] | CMOS I/O-TS | Data Bus Bit [31:0] – a 32-bit synchronous data bus. Note: During the system RESET period, Data Bit [31:28] are used as Processor Interface Configuration bit [0:3] |
| S_MSGEN# | CMOS I/O-TS | Message Envelope – encompasses the entire period of a message transfer. Targets use the leading edge of this signal to detect the beginning of a message transfer, and to decode the message header for the intended target(s). |
| S_EOF# | CMOS I/O-TS | End of Frame – only used by frame data transfer messages to identify the end of frame condition. This signal is synchronous with the Rx Frame Status word appended to the end of the message. |
| S_IRDY | CMOS I/O-TS | Initiator Ready – a normal true signal. When negated, it indicates the initiator had asserted wait state(s) in between command words. Target should use this signal as enable signal for latching the data from the bus. |
| S_TABT# | CMOS I/O-OD | Target Abort – when asserted, the target had aborted the reception of current message on the bus. |
| S_HPREQ# | CMOS I/O-OD | High Priority Request – indicates one or more Bus Requester is requesting for high priority message transfer. |
| S_REQ[8:1]# | CMOS Input | Bus Request [8:1] – Bus Request signals from Access Controllers to Bus Access Arbitrator in XpressFlow Engine |
| S_GNT[8:1]# | CMOS Output | Bus Grant [8:1] – Bus Grant signals from Bus Arbitrator to Bus Requesters |
| S_OVLD# | CMOS Output | Bus Overload – when asserted all data forwarding bus bandwidth has been allocated. Cannot support additional load for data forwarding traffic |
| S_CLK | CMOS Input | XpressFlow Bus Clock – 33MHz system clock |

2.4.2 Bus Cycle Waveforms

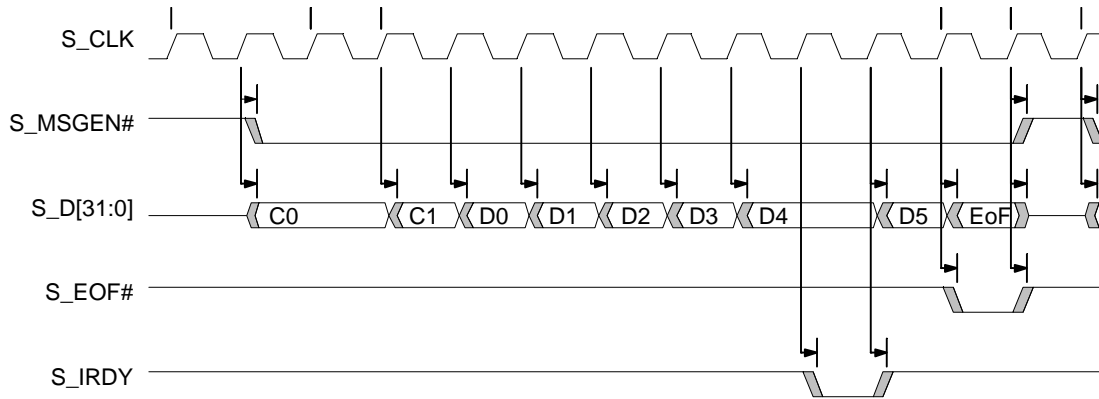

XpressFlow Bus Data Transfer Cycle

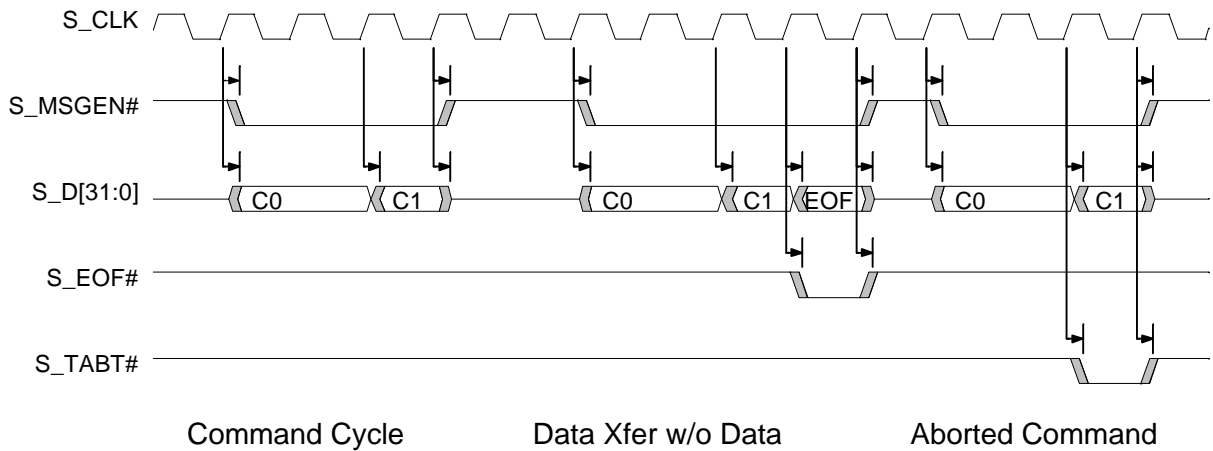

Other XpressFlow Bus Cycles

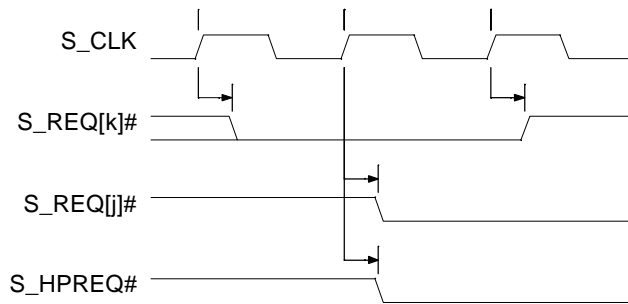

High Priority Request pre-empts the low priority request

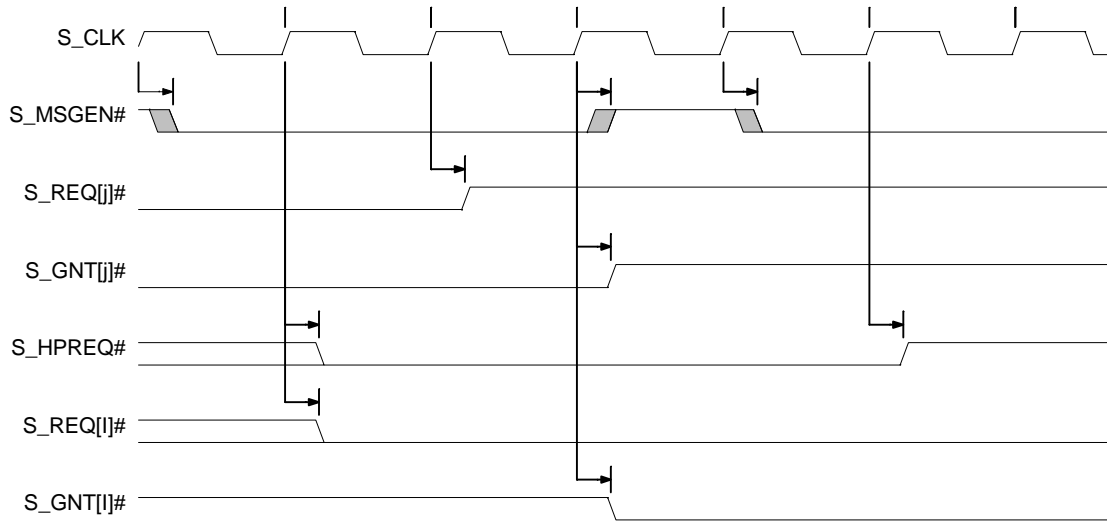

XpressFlow Bus arbitration

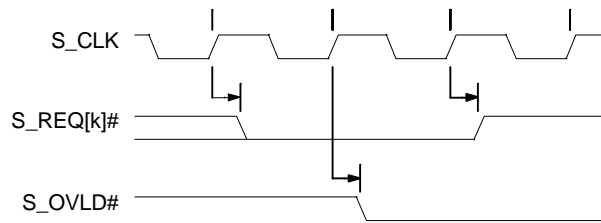

Bus Overload pre-empts the data transfer request

2.5 Test Pins

| Symbol | Type | Name & Functions |
|--------|----------|---------------------------------------------------------------------------------------------------------------------------|
| TEST | CMOS I/O | Test Mode Selection & Test Output – Set Test Mode upon Reset, and provides test status output during test mode |

3 DC SPECIFICATION

3.1 ABSOLUTE MAXIMUM RATINGS

| | |
|--------------------------------------------------|-------------------------------|
| Storage Temperature | -65 C to +150 C |
| Operating Temperature | 0 C to +70 C |
| Supply Voltage V_{DD} with Respect to V_{SS} | +3.0 V to +3.6 V |
| Voltage on 5V Tolerant Input Pins | -0.5 V to ($V_{DD} + 2.5$ V) |
| Voltage on Other Pins | -0.5 V to ($V_{DD} + 0.3$ V) |

Stresses above those listed may cause permanent device failure. Functionality at or above these limits is not implied. Exposure to Absolute Maximum Ratings for extended periods may affect device reliability.

3.2 DC CHARACTERISTICS

$V_{DD} = 3.0$ V to 3.6 V; $T_{AMBIENT} = 0$ C to +70 C

| Symbol | Parameter Description | Preliminary | | | Unit |
|---------------|-----------------------------------------------------------------------------------------------------------------------|----------------------|-----|----------------------|------|
| | | Min | Typ | Max | |
| f_{osc} | Frequency of Operation (-40) | 20 | | 40.0000 | MHz |
| | Frequency of Operation (-50) | 20 | | 50.0000 | MHz |
| | Frequency of Operation (-66) | 20 | | 66.6666 | MHz |
| I_{DD} | Supply Power – @ 33.3333 MHz ($V_{DD}=3.3$ V) | | 300 | 500 | mA |
| | Supply Power – @ 40 MHz ($V_{DD}=3.3$ V) | | 300 | 500 | mA |
| | Supply Power – @ 50 MHz ($V_{DD}=3.3$ V) | | 300 | 500 | mA |
| $V_{OH-CMOS}$ | Output High Voltage (CMOS) $I_{OH} = -1.0$ mA | $V_{DD} - 0.5$ | | | V |
| $V_{OL-CMOS}$ | Output Low Voltage (CMOS) $I_{OL} = 1.0$ mA | | | 0.45 | V |
| V_{OH-TTL} | Output High Voltage (TTL) $I_{OH} = -1.0$ mA | 2.4 | | | V |
| V_{OL-TTL} | Output Low Voltage (TTL) $I_{OL} = 1.0$ mA | | | 0.45 | V |
| $V_{IH-CMOS}$ | Input High Voltage (CMOS) | $V_{DD} \times 70\%$ | | $V_{DD} + 0.3$ | V |
| $V_{IL-CMOS}$ | Input Low Voltage (CMOS) | -0.5 | | $V_{DD} \times 30\%$ | V |
| V_{IH-TTL} | Input High Voltage (TTL) | 2.0 | | $V_{DD} + 0.3$ | V |
| V_{IL-TTL} | Input Low Voltage (TTL) | -0.3 | | +0.8 | V |
| V_{IH-5VT} | Input High Voltage (TTL 5V tolerant) | 2.0 | | $V_{DD} + 2.5$ | V |
| V_{IL-5VT} | Input Low Voltage (TTL 5V tolerant) | -0.3 | | +0.8 | V |
| I_{LI} | Input Leakage Current (0.1 V V_{IN} V_{DD}) (all pins except those with internal pull-up/pull-down resistors) | | | 10 | A |
| I_{LO} | Output Leakage Current (0.1 V V_{OUT} V_{DD}) | | | 15 | A |
| I_{IH} | Input Leakage Current $V_{IH} = V_{DD} - 0.1$ V (pins with internal pull-down resistors) | | | 60 | A |
| I_{IL} | Input Leakage Current $V_{IL} = 0.1$ V (pins with internal pull-up resistors) | | | -60 | A |
| C_{IN} | Input Capacitance | | | 8 | pF |
| C_{OUT} | Output Capacitance | | | 8 | pF |
| $C_{I/O}$ | I/O Capacitance | | | 10 | pF |

4 AC SPECIFICATION

4.1 XpressFlow Bus Interface:

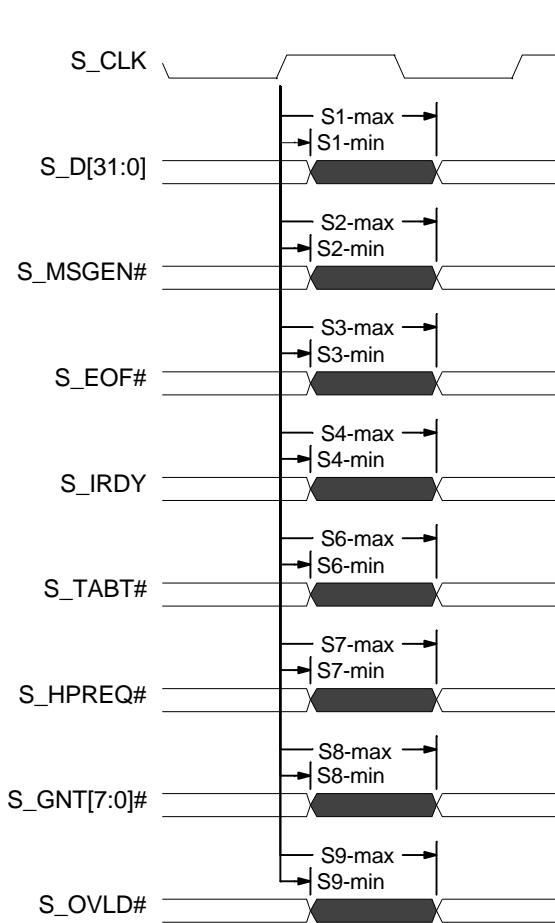

**XpressFlow Bus Interface –
Output valid delay timing**

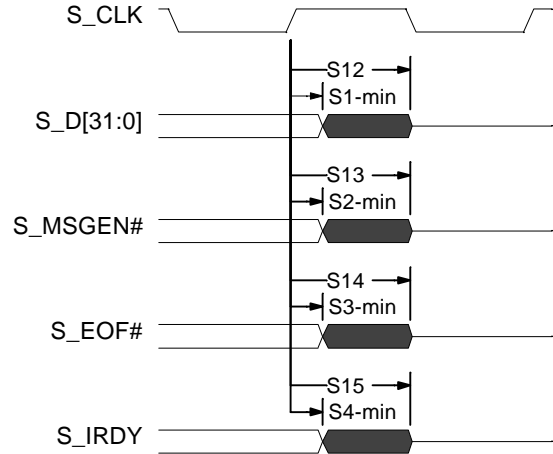

**XpressFlow Bus Interface –
Output float delay timing**

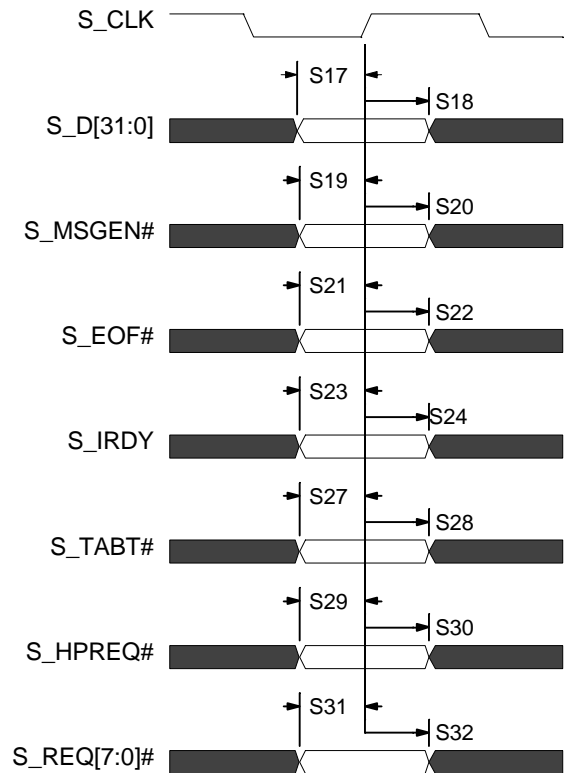

**XpressFlow Bus Interface –
Input setup and hold timing**

| Symbol | Parameter | -40 | | -50 | | -66 | | Note: |
|--------|--------------------------------|----------|----------|----------|----------|----------|----------|-----------------------|
| | | Min (ns) | Max (ns) | Min (ns) | Max (ns) | Min (ns) | Max (ns) | |
| S1 | S_D[31:0] output valid delay | 6 | 14 | 5 | 11 | 4 | 8.5 | C _L = 50pf |
| S2 | S_MSGEN# output valid delay | 6 | 14 | 5 | 11 | 4 | 8.5 | C _L = 50pf |
| S3 | S_EOF# output valid delay | 6 | 14 | 5 | 11 | 4 | 8.5 | C _L = 50pf |
| S4 | S_IRDY output valid delay | 6 | 14 | 5 | 11 | 4 | 8.5 | C _L = 50pf |
| S6 | S_TABT# output valid delay | 6 | 14 | 5 | 11 | 4 | 8.5 | C _L = 50pf |
| S7 | S_HPREQ# output valid delay | 6 | 14 | 5 | 11 | 4 | 8.5 | C _L = 50pf |
| S8 | S_GNT[7:0]# output valid delay | 6 | 14 | 5 | 11 | 4 | 8.5 | C _L = 20pf |
| S9 | S_OVLD# output valid delay | 6 | 14 | 5 | 11 | 4 | 8.5 | C _L = 50pf |
| S12 | S_D[31:0] output float delay | | 18 | | 15 | | 12 | |
| S13 | S_MSGEN# output float delay | | 18 | | 15 | | 12 | |
| S14 | S_EOF# output float delay | | 18 | | 15 | | 12 | |
| S15 | S_IRDY output float delay | | 18 | | 15 | | 12 | |
| S17 | S_D[31:0] input set-up time | 2 | | 1.5 | | 1 | | |
| S18 | S_D[31:0] input hold time | 5.5 | | 4.5 | | 3.5 | | |
| S19 | S_MSGEN# input set-up time | 2 | | 1.5 | | 1 | | |
| S20 | S_MSGEN# input hold time | 5.5 | | 4.5 | | 3.5 | | |
| S21 | S_EOF# input set-up time | 2 | | 1.5 | | 1 | | |
| S22 | S_EOF# input hold time | 5.5 | | 4.5 | | 3.5 | | |
| S23 | S_IRDY input set-up time | 2 | | 1.5 | | 1 | | |
| S24 | S_IRDY input hold time | 5.5 | | 4.5 | | 3.5 | | |
| S27 | S_TABT# input set-up time | 5.5 | | 4.5 | | 3.5 | | |
| S28 | S_TABT# input hold time | 5.5 | | 4.5 | | 3.5 | | |
| S29 | S_HPREQ# input set-up time | 4.5 | | 3.5 | | 2.5 | | |
| S30 | S_HPREQ# input hold time | 5.5 | | 4.5 | | 3.5 | | |
| S31 | S_REQ[7:0]# input set-up time | 6 | | 5 | | 4 | | |
| S32 | S_REQ[7:0]# input hold time | 5.5 | | 4.5 | | 3.5 | | |

AC Characteristics -- XpressFlow Bus Interface

4.2 CPU Bus Interface:

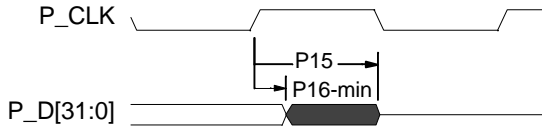

**CPU Bus Interface –
Output float delay timing**

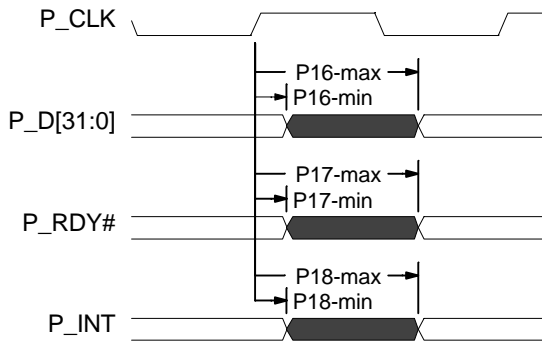

**CPU Bus Interface –
Output valid delay timing**

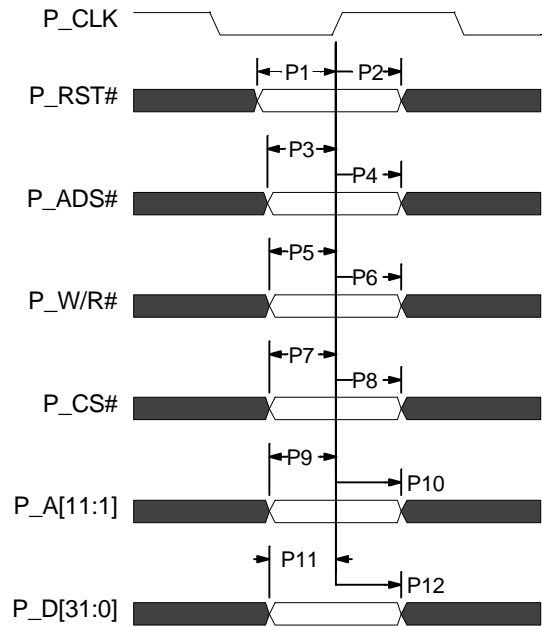

**CPU Bus Interface –
Input setup and hold timing**

| Symbol | Parameter | -40 | | -50 | | -66 | | Note: |
|--------|---------------------------------|----------|----------|----------|----------|----------|----------|-----------------------|
| | | Min (ns) | Max (ns) | Min (ns) | Max (ns) | Min (ns) | Max (ns) | |
| P1 | P_RST# input setup time | 13 | | 10 | | 8 | | |
| P2 | P_RST# input hold time | 3.5 | | 2.5 | | 2 | | |
| P3 | P_ADS# input set-up time | 13 | | 10 | | 8 | | |
| P4 | P_ADS# input hold time | 3.5 | | 2.5 | | 2 | | |
| P5 | P_W/R# input set-up time | 13 | | 10 | | 8 | | |
| P6 | P_W/R# input hold time | 3.5 | | 2.5 | | 2 | | |
| P7 | P_CS# input set-up time | 13 | | 10 | | 8 | | |
| P8 | P_CS# input hold time | 3.5 | | 2.5 | | 2 | | |
| P9 | P_A[11:1] input set-up time | 13 | | 10 | | 8 | | |
| P10 | P_A[11:1] input hold time | 3.5 | | 2.5 | | 2 | | |
| P11 | P_D[31:0]# input set-up time | 13 | | 10 | | 8 | | |
| P12 | P_D[31:0]# input hold time | 3.5 | | 2.5 | | 2 | | |
| P15 | P_D[31:0]# output float delay | | 17 | | 13 | | 10 | |
| P16 | P_D[31:0]# # output valid delay | | 17 | | 13 | | 10 | C _L = 60pf |
| P17 | P_RDY# output valid delay | | 13 | | 10 | | 8 | C _L = 60pf |
| P18 | P_INT# output valid delay | | 8.5 | | 6.5 | | 5 | C _L = 20pf |

AC Characteristics -- CPU Bus Interface

4.3 Local Memory Interface:

Local Memory Interface:

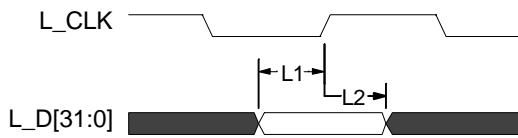

**Local Memory Interface –
Input setup and hold timing**

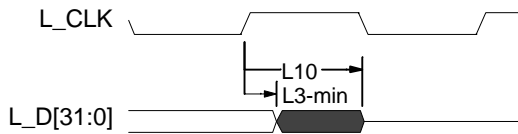

**Local Memory Interface –
Output float delay timing**

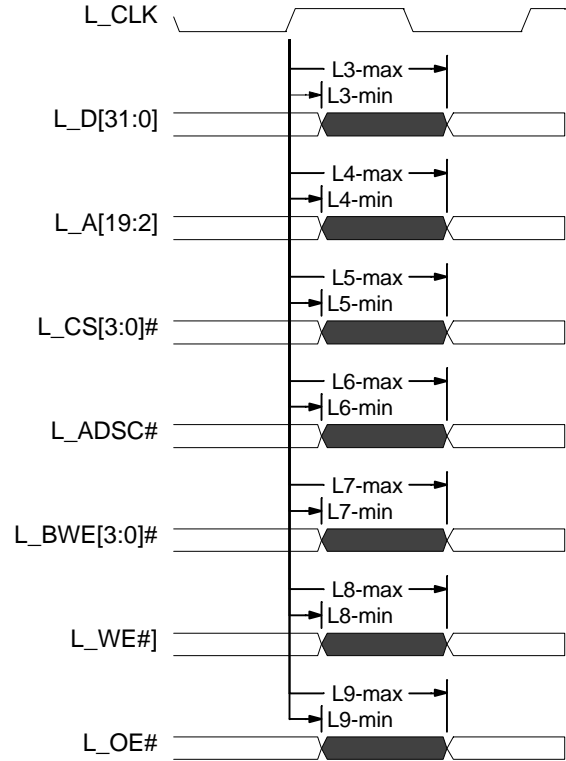

**Local Memory Interface –
Output valid delay timing**

| Symbol | Parameter | -40 | | -50 | | -66 | | Note: |
|--------|--------------------------------|----------|----------|----------|----------|----------|----------|-----------------------|
| | | Min (ns) | Max (ns) | Min (ns) | Max (ns) | Min (ns) | Max (ns) | |
| L1 | L_D[31:0]# input set-up time | 6.5 | | 5.5 | | 4 | | |
| L2 | L_D[31:0]# input hold time | 3 | | 2.5 | | 2 | | |
| L3 | L_D[31:0]# output valid delay | 5 | 17 | 4 | 13 | 3 | 10 | C _L = 30pf |
| L4 | L_A[19:2] output valid delay | 5 | 17 | 4 | 13 | 3 | 10 | C _L = 30pf |
| L6 | L_ADSC# output valid delay | 5 | 17 | 4 | 13 | 3 | 10 | C _L = 30pf |
| L7 | L_BWE[3:0]# output valid delay | 5 | 17 | 4 | 13 | 3 | 10 | C _L = 30pf |
| L8 | L_WE# output valid delay | 5 | 17 | 4 | 13 | 3 | 10 | C _L = 10pf |
| L9 | L_OE# output valid delay | 5 | 17 | 4 | 13 | 3 | 10 | C _L = 10pf |
| L10 | L_D[31:0]# output float delay | | 22 | | 18 | | 14 | |

AC Characteristics – Local Memory Interface

4.4 CAM Memory Interface:

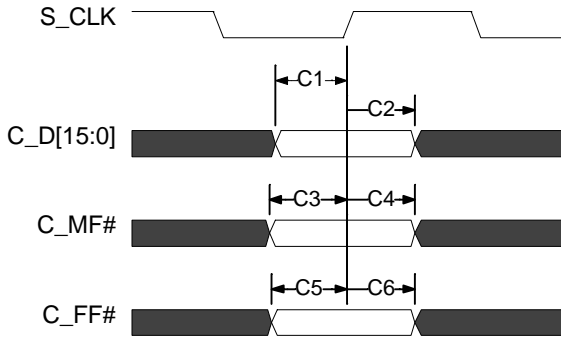

**CAM Memory Interface –
Input setup and hold timing**

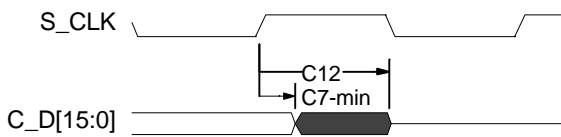

**CAM Memory Interface –
Output float delay timing**

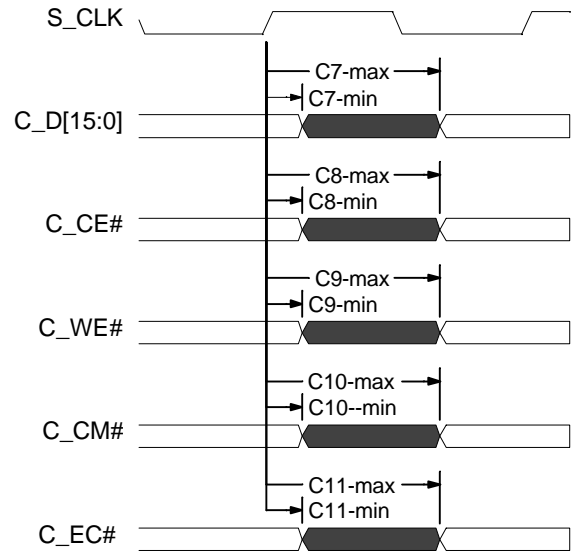

**CAM Memory Interface –
Output valid delay timing**

| Symbol | Parameter | -40 | | -50 | | -66 | | Note: |
|--------|-------------------------------|----------|----------|----------|----------|----------|----------|-------|
| | | Min (ns) | Max (ns) | Min (ns) | Max (ns) | Min (ns) | Max (ns) | |
| C1 | C_D[15:0]# input set-up time | 4.5 | | 4 | | 5 | | |
| C2 | C_D[15:0]# input hold time | 1.5 | | 1.5 | | 2 | | |
| C3 | C_MF# input set-up time | 4.5 | | 4 | | 5 | | |
| C4 | C_MF# input hold time | 1.5 | | 1.5 | | 2 | | |
| C5 | C_FF# input set-up time | 4.5 | | 4 | | 5 | | |
| C6 | C_FF# input hold time | 1.5 | | 1.5 | | 2 | | |
| C7 | C_D[15:0]# output valid delay | 5 | 18 | 4 | 15 | 6 | 20 | |
| C8 | C_CE# output valid delay | 5 | 18 | 4 | 15 | 6 | 20 | |
| C9 | C_WE# output valid delay | 5 | 18 | 4 | 15 | 6 | 20 | |
| C10 | C_CM# output valid delay | 5 | 18 | 4 | 15 | 6 | 20 | |
| C11 | C_EC# output valid delay | 5 | 18 | 4 | 15 | 6 | 20 | |
| C12 | C_D[16:0]# output float delay | | 13 | | 10 | | 15 | |

AC Characteristics – CAM Memory Interface

5 PACKAGING INFORMATION

5.1 256-PIN PQFP

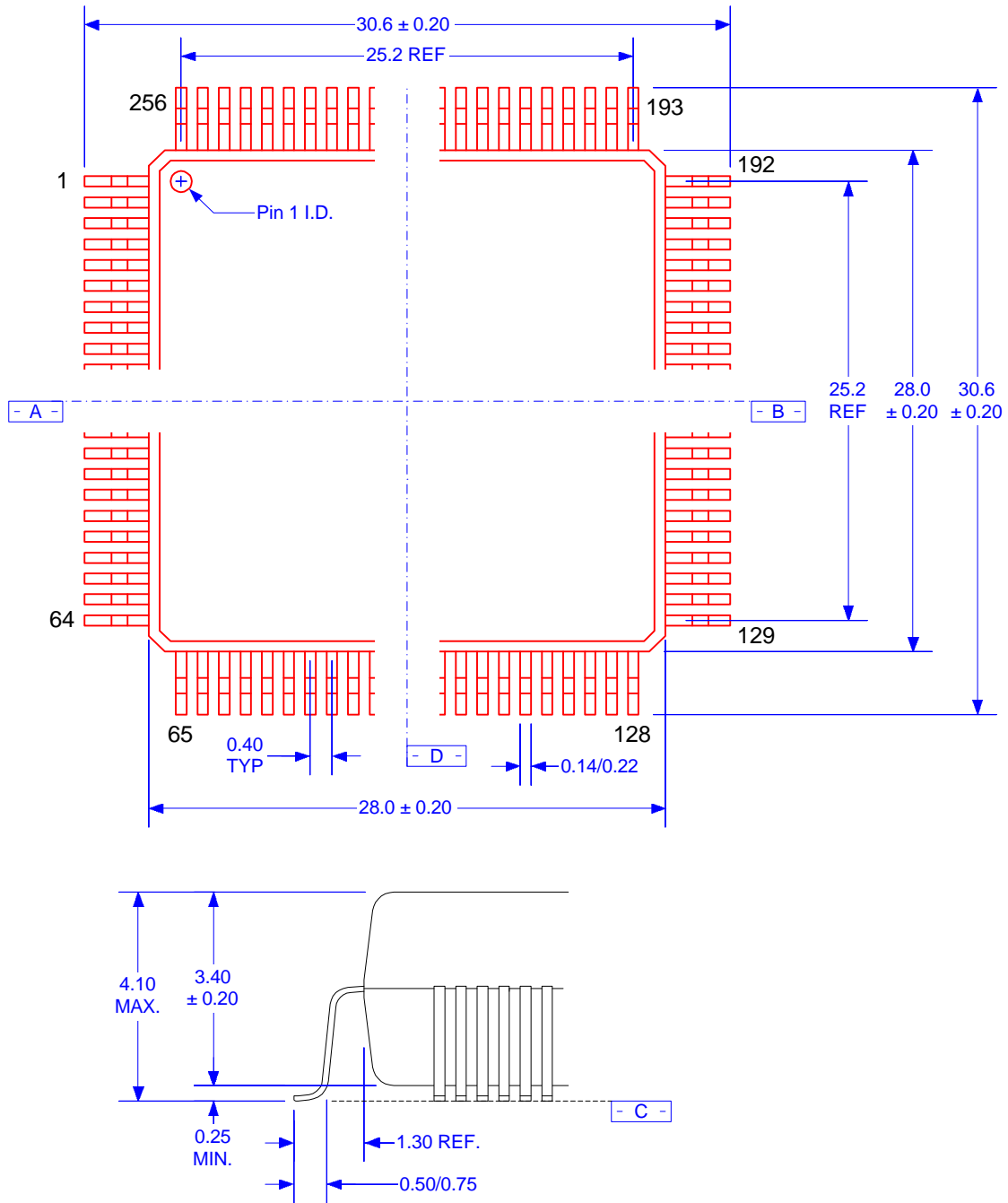

5.2 256- Pin BGA

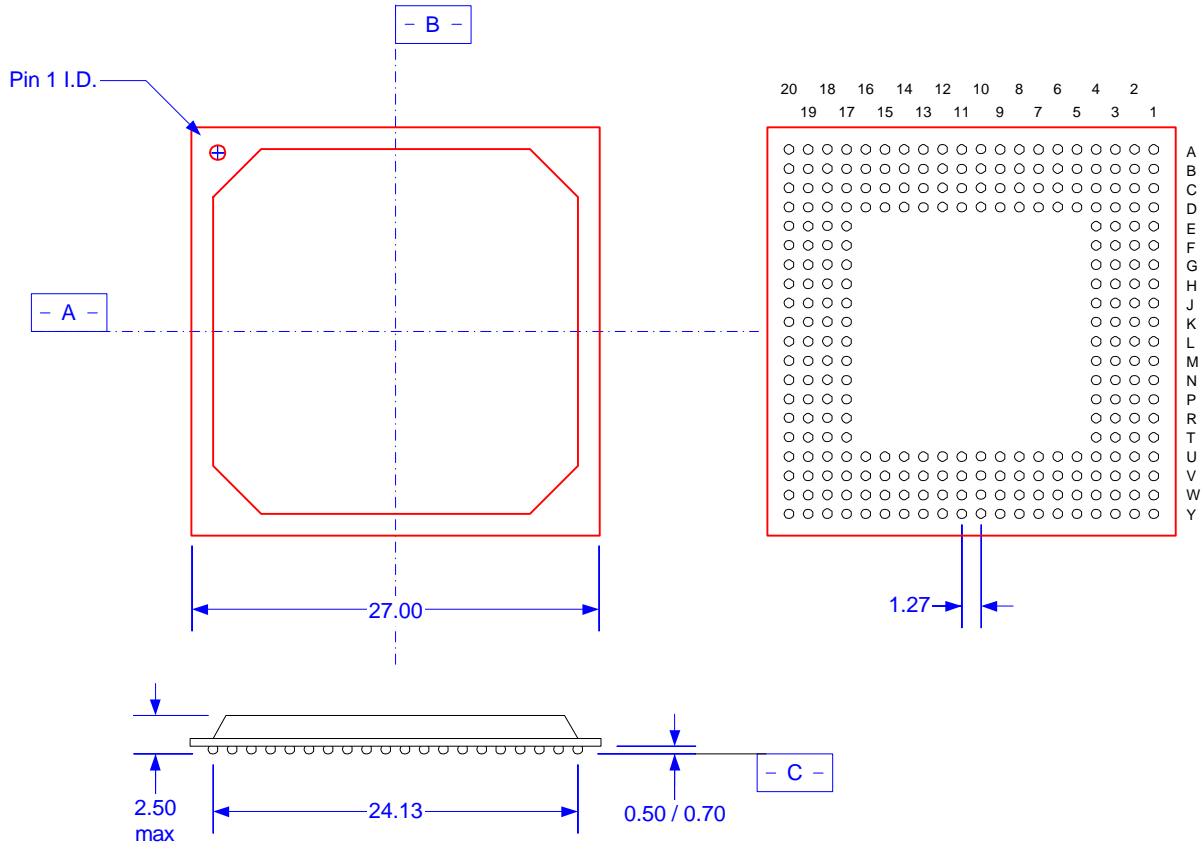

| Ordering Information | | | | |
|----------------------|----------------------------------------|----------------|---------------------|-------------------------------------------------|
| Part Number | Description | Identification | Vertex Networks Use | Revision |
| SC220 | XpressFlow Switch Engine | C 0 B | TAV | rrr |
| Environmental - | C = Commercial I = Industrial | | Revision - | 001 = Rev.1 For latest revision, leave blank |
| Speed grade - | 0 = 40 MHz 5 = 50 MHz 6 = 66 MHz | | | |
| Package - | B = BGA P = PQFP | | | |

This document contains preliminary information on our product. Vertex reserves the right to make any changes without notice.



16842 Von Karman Ave, Suite 250
Irvine, CA 92606-4950
Tel. 1-714-252-8880, FAX: 1-714-252-8868
Web Site: www.vertex-networks.com

Rev. 4.5- February, 1999

© 1998 VERTEX NETWORKS

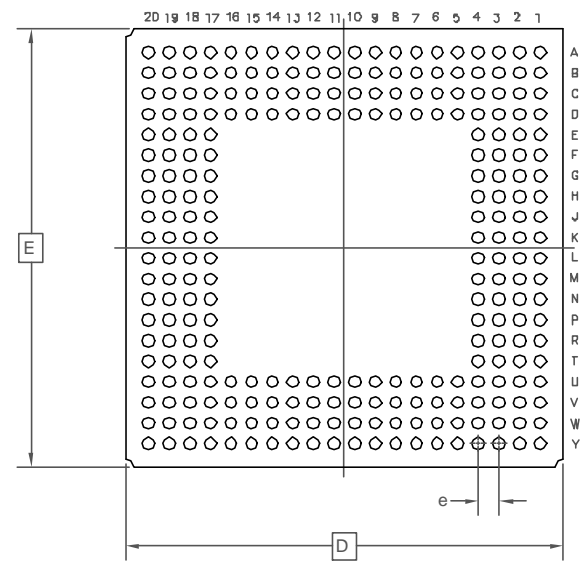
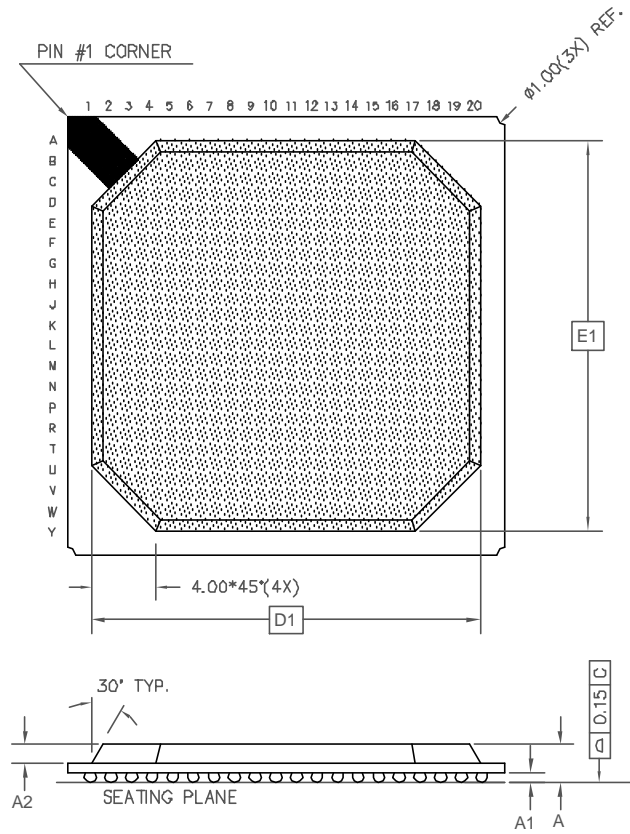

| DIMENSION | MIN | MAX |
|----------------------------|-----------|-------|
| A | 2.20 | 2.46 |
| A1 | 0.50 | 0.70 |
| A2 | 1.17 REF | |
| D | 26.80 | 27.20 |
| D1 | 24.00 REF | |
| E | 26.80 | 27.20 |
| E1 | 24.00 REF | |
| b | 0.60 | 0.90 |
| e | 1.27 | |
| N | 256 | |
| Conforms to JEDEC MS - 034 | | |

1. CONTROLLING DIMENSIONS ARE IN MM
2. DIMENSION "b" IS MEASURED AT THE MAXIMUM SOLDER BALL DIAMETER
3. PRIMARY DATUM -C- AND SEATING PLANE ARE DEFINED BY THE SPHERICAL CROWNS OF THE SOLDER BALLS.
4. N IS THE NUMBER OF SOLDER BALLS
5. NOT TO SCALE.
6. SUBSTRATE THICKNESS IS 0.56 MM

| | | | | | | |
|---------------------------------------------------|--------|--|--|--------------------------------------------------------------------------------------|-------------------------|--------------------------------------------------|
| © Zarlink Semiconductor 2003 All rights reserved. | | | |  | Package Code | GA |
| ISSUE | 1 | | | | Previous package codes: | Package Outline for 256 Ball PBGA (27x27x2.33mm) |
| ACN | 213983 | | | | BP / G | |
| DATE | 3Feb03 | | | | | |
| APPRD. | | | | | | |
| | | | | | | GPD00827 |

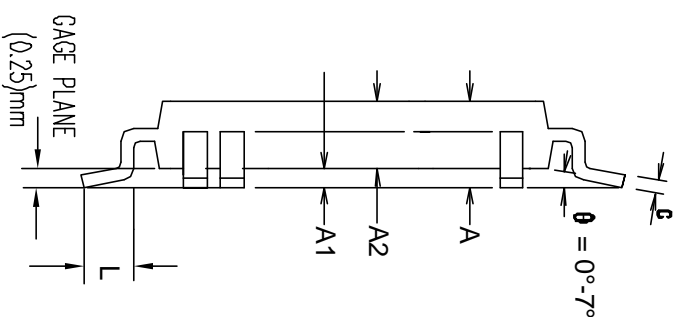
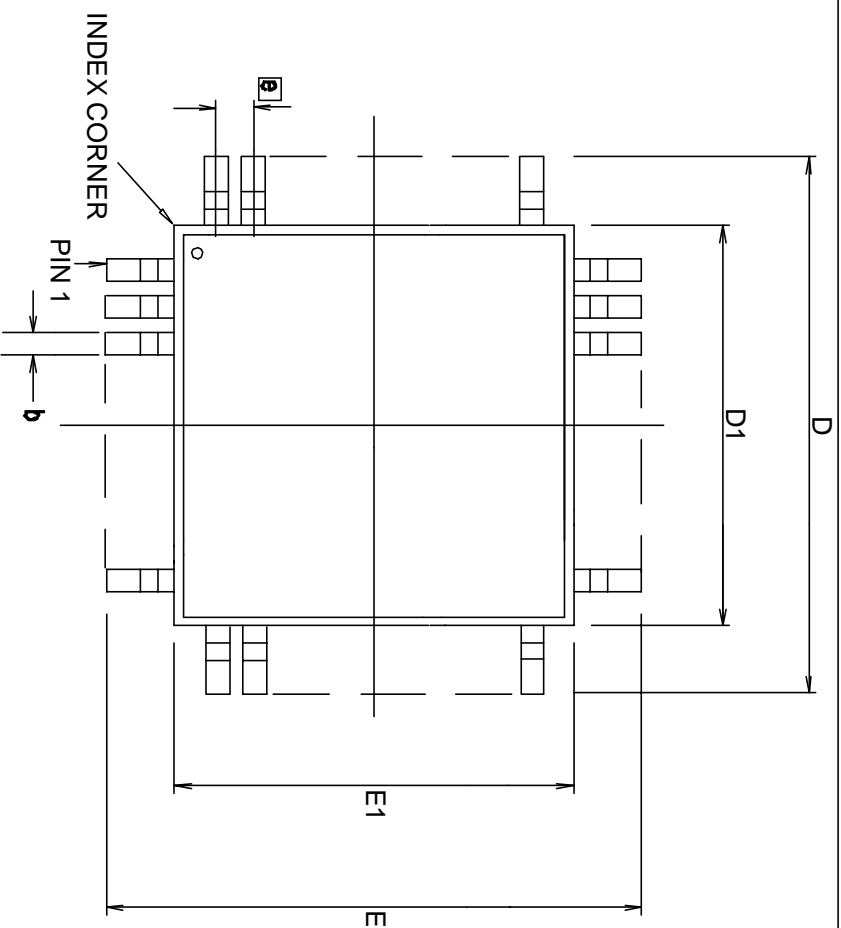

| Symbol | Control Dimensions in millimetres | | |
|----------|--------------------------------------|---------|------|
| | MIN | Nominal | MAX |
| A | — | — | 4.10 |
| A1 | 0.25 | — | — |
| A2 | 3.20 | 3.32 | 3.60 |
| D | 30.60 | BSC | — |
| D1 | 28.00 | BSC | — |
| E | 30.60 | BSC | — |
| E1 | 28.00 | BSC | — |
| L | 0.45 | 0.60 | 0.75 |
| e | — | 0.40 | BSC |
| b | 0.13 | 0.16 | 0.23 |
| c | 0.09 | 0.15 | 0.20 |
| θ | 0° | — | 7° |
| ccc | — | 0.08 | — |
| N | — | 256 | — |
| ND | — | 64 | — |
| NE | — | 64 | — |

Conforms to JEDEC MO-143

Notes:

1. Pin 1 indicator may be a corner chamfer, dot or both.
2. Controlling dimensions are in millimeters.
3. The top package body size may be smaller than the bottom package body size by a max. of 0.15 mm.
4. Dimension D1 and E1 do not include mould protusion.
5. Dimension b does not include dambar protusion.

© Zarlink Semiconductor 2003 All rights reserved.

| | | | |
|--------|---------|--|--|
| ISSUE | 1 | | |
| ACN | 21.3985 | | |
| DATE | 3Feb03 | | |
| APPRD. | | | |



Previous package codes:

GP / L

Package Code **QB**

Package Outline for 256 Lead
MQFP (28x28x3.32mm) + 2.6
mm (footprint)

GP D00829



**For more information about all Zarlink products
visit our Web Site at
www.zarlink.com**

Information relating to products and services furnished herein by Zarlink Semiconductor Inc. or its subsidiaries (collectively "Zarlink") is believed to be reliable. However, Zarlink assumes no liability for errors that may appear in this publication, or for liability otherwise arising from the application or use of any such information, product or service or for any infringement of patents or other intellectual property rights owned by third parties which may result from such application or use. Neither the supply of such information or purchase of product or service conveys any license, either express or implied, under patents or other intellectual property rights owned by Zarlink or licensed from third parties by Zarlink, whatsoever. Purchasers of products are also hereby notified that the use of product in certain ways or in combination with Zarlink, or non-Zarlink furnished goods or services may infringe patents or other intellectual property rights owned by Zarlink.

This publication is issued to provide information only and (unless agreed by Zarlink in writing) may not be used, applied or reproduced for any purpose nor form part of any order or contract nor to be regarded as a representation relating to the products or services concerned. The products, their specifications, services and other information appearing in this publication are subject to change by Zarlink without notice. No warranty or guarantee express or implied is made regarding the capability, performance or suitability of any product or service. Information concerning possible methods of use is provided as a guide only and does not constitute any guarantee that such methods of use will be satisfactory in a specific piece of equipment. It is the user's responsibility to fully determine the performance and suitability of any equipment using such information and to ensure that any publication or data used is up to date and has not been superseded. Manufacturing does not necessarily include testing of all functions or parameters. These products are not suitable for use in any medical products whose failure to perform may result in significant injury or death to the user. All products and materials are sold and services provided subject to Zarlink's conditions of sale which are available on request.

Purchase of Zarlink's I²C components conveys a licence under the Philips I²C Patent rights to use these components in and I²C System, provided that the system conforms to the I²C Standard Specification as defined by Philips.

Zarlink, ZL and the Zarlink Semiconductor logo are trademarks of Zarlink Semiconductor Inc.

Copyright Zarlink Semiconductor Inc. All Rights Reserved.

TECHNICAL DOCUMENTATION - NOT FOR RESALE
