

High Current Surge Protection Diode Array

Low Capacitance

ESD70V14T-LC

Description

The ESD70V14T-LC is designed to protect voltage sensitive components from ESD and transient voltage events. Excellent clamping capability, low leakage, and fast response time, make these parts ideal for ESD protection on designs where board space is at a premium.

Feature

- u Array of surge rated, low capacitance diodes
- u Protects two I/O lines
- u Low capacitance (5pF typical) for high-speed interfaces
- u Low clamping voltage
- u RoHS Compliant
- u IEC61000-4-2 (ESD) ±15kV (air), ±8kV (contact)
- u IEC61000-4-4 (EFT) 40A (5/50ns)
- u IEC61000-4-5 (Lightning) 24A (8/20µs)

Applications

- u ADSL Lines
- u I²C Bus Protection
- u Video Line Protection
- u T1/E1 secondary IC Side Protection
- u Portable Electronics
- u Microcontroller Input Protection
- u WAN/LAN Equipment
- u ISDN S/T Interface

SOT-143



Functional Diagram

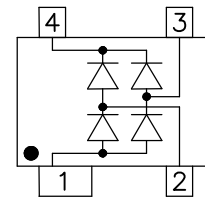

Mechanical Characteristics

- u JEDEC SOT-143 Package
- u Molding Compound Flammability Rating : UL 94V-0
- u Weight 10.0 Milligrams (Approximate)
- u Quantity Per Reel : 3,000pcs
- u Reel Size : 7 inch
- u Lead Finish : Lead Free

Mechanical Characteristics

Symbol	Parameter	Value	Units
P _{PP}	Peak Pulse Power (tp=8/20µs waveform)	100	W
T _L	Lead Soldering Temperature	260 (10sec)	°C
T _{STG}	Storage Temperature Range	-55 to +150	°C
T _J	Operating Temperature Range	-55 to +150	°C
	IEC61000-4-2 (ESD)	Air Discharge ±15 Contact Discharge ±8	KV
	IEC61000-4-4 (EFT)	40	A
	IEC61000-4-5 (Lightning)	5	A

High Current Surge Protection Diode Array

Low Capacitance

ESD70V14T-LC

Electrical Characteristics (@ 25°C Unless Otherwise Specified)

Part Number	Device Marking	V _{RWM} (V) (Max.)	V _B (V) (Min.)	I _T (mA)	V _{FC} @1A (Max.)	V _{FC}		I _R (μA) (Max.)	C (pF) (Typ.)
						(Max.)	(@A)		
ESD70V14T-LC	CKA	70	100	50	1.5	8	24	1	5

Characteristic Curves

Fig1. 8/20μs Pulse Waveform

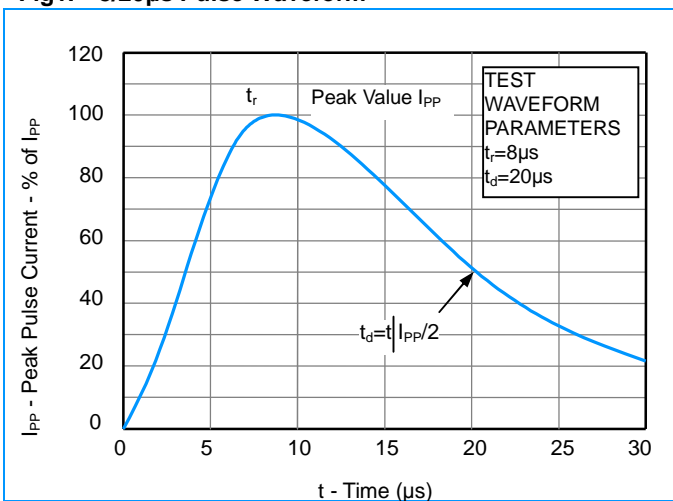
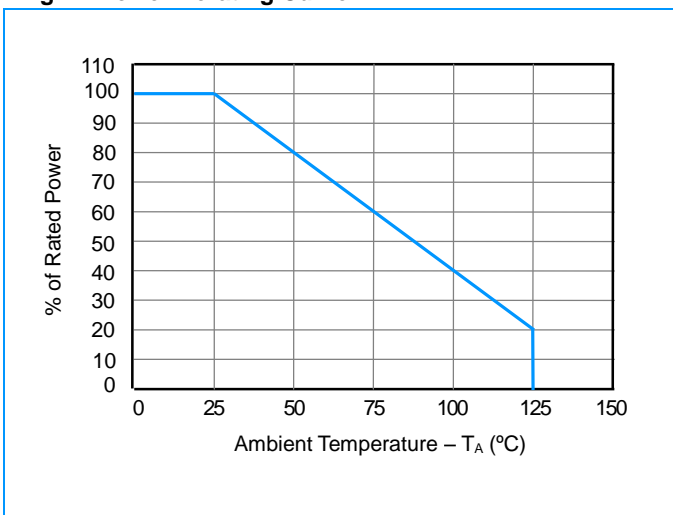

Fig2. Power Derating Curve



High Current Surge Protection Diode Array

Low Capacitance

ESD70V14T-LC

SOT-143 Package Outline & Dimensions

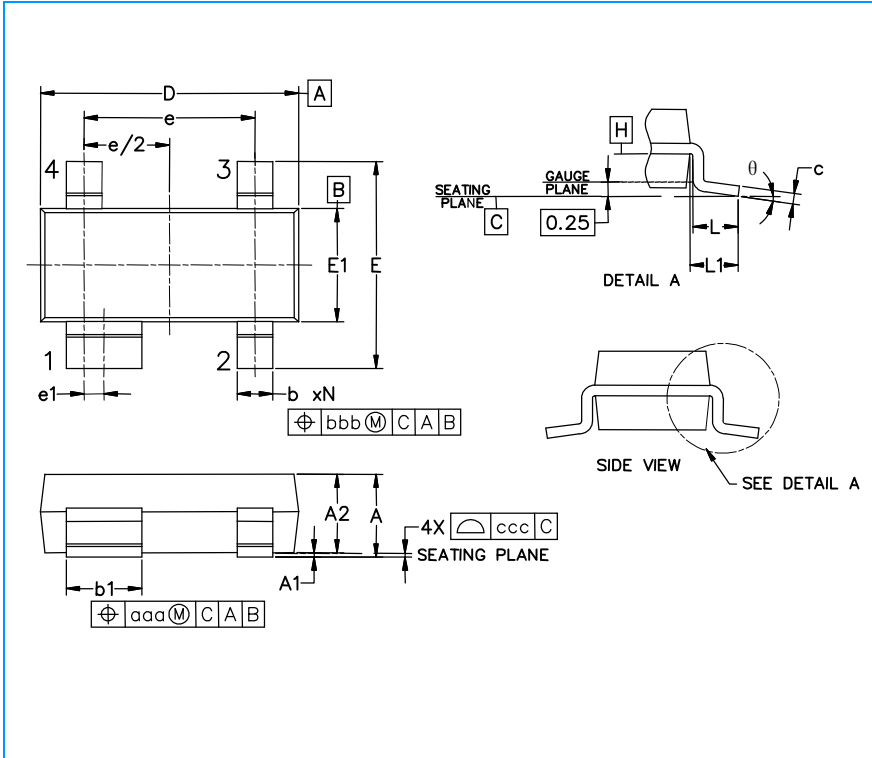

Symbol	Inches			Millimeters		
	Min.	Nom.	Max.	Min.	Nom.	Max.
A	0.031	-	0.048	0.80	-	1.22
A1	0.000	-	0.008	0.013	-	0.15
A2	0.020	0.035	0.042	0.75	0.90	1.07
b	0.011	-	0.020	0.30	-	0.51
b1	0.029	-	0.037	0.76	-	0.94
c	0.003	-	0.008	0.08	-	0.20
D	0.110	0.114	0.120	2.80	2.90	3.04
E	0.082	0.093	0.104	2.10	2.37	2.64
E1	0.047	0.051	0.055	1.20	1.30	1.40
e	0.075		1.92 BSC			
e1	0.008		0.20 BSC			
L	0.015	0.020	0.024	0.40	0.50	0.60
L1	(0.021)		(0.54)			
N	4		4			
θ	0°	-	8°	0°	-	8°
aaa	0.006		0.15			
bbb	0.008		0.20			
ccc	0.004		0.10			

Soldering Footprint

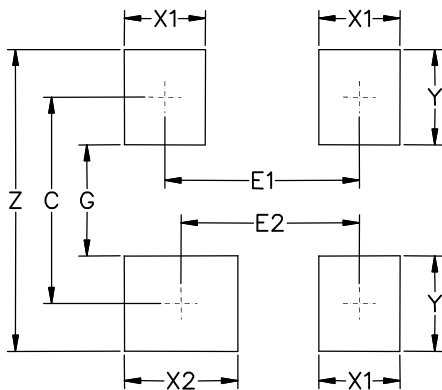

Symbol	Inches	Millimeters
C	(0.087)	(2.20)
E1	0.076	1.92
E2	0.068	1.72
G	0.031	0.80
X1	0.039	1.00
X2	0.047	1.20
Y	0.055	1.40
Z	0.141	3.60