

K1524A Series 14 DIP, 5.0 Volt, CMOS/TTL, VCXO



- Former **Champion Technologies, Inc.** Product
- Phase-Locked Loops (PLL's), Clock Recovery, Reference Signal Tracking, Synthesizers, Frequency Modulation/Demodulation

Ordering Information

00.0000
MHz

K1524AA X

Product Series _____

Temperature Range _____

Blank: 0°C to +70°C

M: -40°C to +85°C

Frequency (customer specified) _____

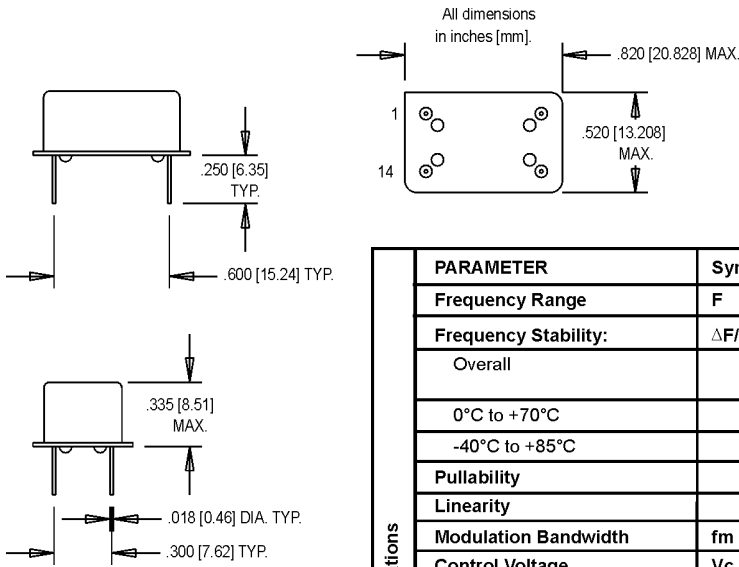

Pin Connections

PIN	FUNCTION
1	Voltage Control
7	Ground/Case Ground
8	Output
14	+Vdd

PARAMETER	Symbol	Min.	Typ.	Max.	Units	Condition
Frequency Range	F	3		35	MHz	
Frequency Stability:	$\Delta F/F$					
Overall		Inclusive of Calibration, Temperature, Voltage, Load, and Aging				
0°C to +70°C				±50	ppm	
-40°C to +85°C				±70	ppm	
Pullability		±300		±525	ppm	
Linearity				15	%	
Modulation Bandwidth	fm	>20			kHz	±3dB
Control Voltage	Vc	0.5	2.5	4.5	V	
Transfer Function		Positive				
Input Impedance		>50K Ω				@ 10 kHz
Operating Temperature	Ta	-40		+85	°C	
Storage Temperature	Ts	-40		+125	°C	
Input Voltage	Vdd	4.75	5.0	5.25	V	
Input Current	Idd			26	mA	
Symmetry (Duty Cycle)		40		60	%	@ 50% Vdd
Rise Time (TTL)	Tr			4	ns	20% to 80% Vdd
Rise Time (CMOS)	Tr			5	ns	20% to 80% Vdd, CL=15pF
Fall Time (TTL)	Tf			4	ns	80% to 20% Vdd
Fall Time (CMOS)	Tf			4	ns	80% to 20% Vdd, CL=15pF
Logic "1" Level	Voh	Vdd-0.5			V	
Logic "0" Level	Vol			0.5	V	
Start up Time				10	ms	
Phase Noise (Typical)	10 Hz	100 Hz	1 kHz	10 kHz	100 kHz	Offset from carrier
		-65	-95	-120	-140	-150
Environmental	Temperature Cycle	MIL-STD-883, Method 1010, Condition B			-55°C to +125°C; Air-to-Air; 100 cycles; 10 min. dwell	
	Mechanical Shock	MIL-STD-883, Method 2002, Condition B			1500 g's	
	Vibration	MIL-STD-883, Method 2007, Condition B			20-2000 Hz; 0.06 inch; 15 g's; 3 planes	
	Humidity Steady State	MIL-STD-202, Method 103			40°C; 90%-95% R.H.; 56 days	
	Thermal Shock	MIL-STD-883, Method 1011.7, Cond. B			100°C to 0°C; Water-to-Water; 15 cycles	
	Electrostatic Discharge	MIL-STD-883, Method 3015, Class II			2 KV to 4 KV Threshold	
	Solderability	MIL-STD-883, Method 2022.2			Solder dip; Meniscograph Criteria	
	Hermeticity	MIL-STD-883, Method 1014.8, Cond. A1			Mass spectro. 2 x 10 ⁻⁸ atoms. CC/sec He	
	Resistance to Soldering	See Page 147				
	Lead Integrity	MIL-STD-883, Mtd. 2004.5, Cond. A,B1			Lead tension & bend stress	
Marking Permanence	MIL-STD-883, Method 2015.8			Resistance to solvents		
Life Test	MIL-STD-883, Method 1005.6			125°C, powered, 1000 hours minimum		

VCXO

M-tron reserves the right to make changes to the product(s) and service(s) described herein without notice. No liability is assumed as a result of their use or application. No rights under any patent accompany the sale of such product.