

500mA Synchronous Step-Down DC/DC Converters ME3101 Series

Description:

ME3101 series is a group of synchronous rectification type DC/DC converters with a built-in 0.6Ω P-channel driver transistor and 0.7Ω N-channel switching transistor, designed to allow the use of ceramic capacitors. The ICs enable a high efficiency, stable power supply with an output current of 500mA to be configured using only a coil and two capacitors connected externally.

With the built-in oscillator, oscillation frequency is 1.2MHz. As for operation mode, the ME3101 series can be manually switched with automatic PWM/PFM switching control mode, allowing fast response, low ripple and high efficiency over the full range of load (from light load to high output current conditions).

During standby, all circuits are shutdown to reduce current consumption to as low as $1.0\mu\text{A}$ or less.

Feature:

- Synchronous Step-Down DC/DC
- High Efficiency :93%(TYP)
- Low Ripple Voltage :10mV
- Output Current :500mA
- Oscillation Frequency :1.2MHz
- PWM/PFM Automatic Switching Control
- Maximum Duty Ratio :100%
- Ceramic Capacitor Compatible
- Ultra Small Packages :SOT-23-5L
- Soft-start circuit built-in

Typical Application:

- Mobile phones (PDC, GSM, CDMA, IMT200 etc.)
- Bluetooth equipment
- PDA
- Portable communication modem
- Portable games
- Cameras
- Digital cameras
- Cordless phones
- Notebook computers

Typical Application Circuit:

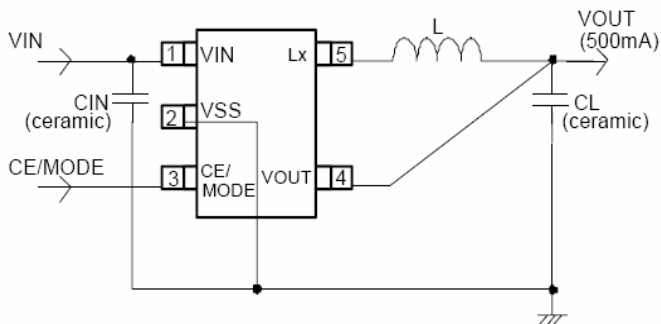

Typical Performance Characteristics:

Efficiency vs. Output Current

$L=3.3\mu\text{H}$, $C_{in}=4.7\mu\text{F}$, $C_L=10\mu\text{F}$, $T_{opr}=25^\circ\text{C}$

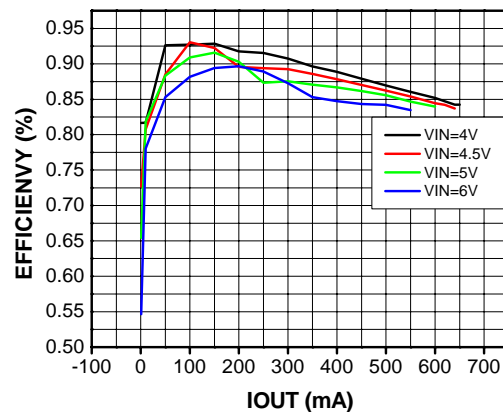

Pin Configuration:

Pin information:

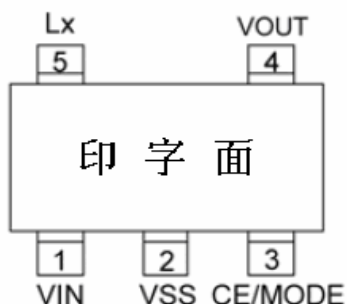

ME3101AXX	Pin Name	Function
Pin Number		
1	VIN	Power Input
2	VSS	Ground
3	CE/MODE	Chip Enable / Mode Switch
4	VOUT	Output Voltage Sence
5	LX	Switching Output

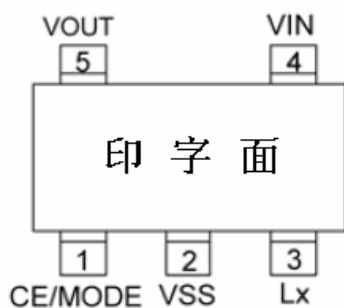

ME3101AXX-DS	Pin Name	Function
Pin Number		
1	CE/MODE	Chip Enable / Mode Switch
2	VSS	Ground
3	LX	Switching Output
4	VIN	Power Input
5	VOUT	Output Voltage Sence

Block Diagram:

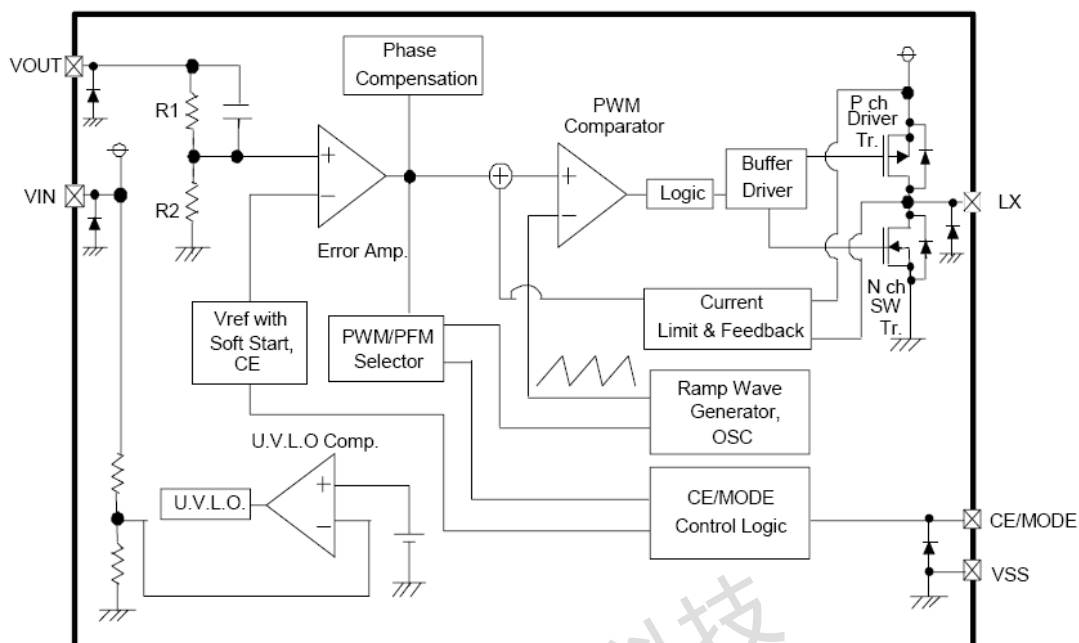

Absolute Maximum Rang:

PARAMETER	SYMBOL	RATINGS	UNITS
VIN Pin Voltage	Vin	-0.3~6.5	V
Lx Pin Voltage	Vlx	-0.3~Vin+0.3	V
VOUT Pin Voltage	Vout	-0.3~6.5	V
CE / MODE Pin Voltage	Vce	-0.3~Vin+0.3	V
Lx Pin Current	Ilx	±1000	mA
Power Dissipation(SOT-23-5L)	Pd	250	mW
Operating Temperature Range	T _{Opr}	-25~+85	°C
Storage Temperature Range	T _{stg}	-40~+125	°C

Electrical Characteristics:

ME3101A10 (Unless Otherwise Stated ,VIN=3.0V, FOSC=1.2MHz, Cin=4.7uF, CL=10uF, L=3.3uH, Ta=25°C)

PARAMETER	SYMBOL	CONDITIONS	MIN.	TYP.	MAX.	UNIT	CIRCUIT
Output Voltage	Vout	Vce=Vin,Iout=30mA	0.98	1.0	1.02	V	①
Operating Voltage Range	Vin		2	—	6	V	①
Maximum Output Current	Iout.max		—	500	—	mA	①
U.V.L.O . Voltage	Vuvlo	Vce=Vin,Vout=0V, LX Voltage which Lx pin voltage holding "L" level	—	1.2	—	V	②
Supply Current	Idd	Vin=Vce=3.0V, Vout=Vout×1.1	—	55	—	uA	③
Stand-by Current	Istb	Vin=3.0V, Vce=0V, Vout=Vout×1.1	—	0	1	uA	③
Frequency	FOSC	Iout=100mA	1020	1200	1380	KHz	①
PFM Switch Current	Ipfm	Vce=Vin, Iout=1mA	—	180	—	mA	①
Maximum Duty Ratio	Maxdty	Vce=Vin, Vout=0	100	—	—	%	④
Minimum Duty Ratio	Mindty	Vce=Vout=Vin	—	—	0	%	④
Efficiency	EFFI	Vce=Vin=2.5V, Iout=100mA	—	90	—	%	①
Lx SW "H" ON Resistance	RlxH	Vce=0.5Vin, Vce=0V, Ilx=100mA	—	0.5	1.2	Ω	⑤
Lx SW "L" ON Resistance	RlxL	Vce=0.5Vin, Ilx=100mA	—	0.6	1.4	Ω	—
Lx SW "H" Leak Current	IleakH	Vin=Vout=5.0V, Vce=0V, Lx=0V	—	0.01	1	uA	⑥
Lx SW "L" Leak Current	IleakL	Vin=Vout=5.0V, Vce=0V, Lx=5V	—	0.01	1	uA	⑥
Current Limit	Ilim	Vin=Vce=5.0V, Vout=0V	—	800	—	mA	⑦
Output Voltage Temperature Characteristics	Vout/ (Vout* Δtopr)	Iout=30mA,-40°C≤Topr≤85°C	—	+100	—	ppm/°C	①
CE "H" Voltage	VceH	Vout=0V	0.7	—	Vin	V	⑧
CE "L" Voltage	VceL	Vout=0V	Vss	—	0.6	V	⑧
CE "H" Current	Iceh	Vin=Vce=5.5V, Vout=0V	-0.1	—	0.1	uA	⑧
CE "L" Current	Icel	Vin=5.5V, Vce=0V, Vout=0V	-0.1	—	0.1	uA	⑧
Soft-Start Time	Tss	Vce=0V~Vin, Iout=1mA	0.5	1.2	3.0	msec	①
Latch Time	Tlat	Vin=Vce=5.0V	1	—	20	msec	⑨

ME3101A12 (Unless Otherwise Stated ,VIN=3.0V, FOSC=1.2MHz, Cin=4.7uF, CL=10uF, L=3.3uH, Ta=25°C)

PARAMETER	SYMBOL	CONDITIONS	MIN.	TYP.	MAX.	UNIT	CIRCUIT
Output Voltage	Vout	Vce=Vin, Iout=30mA	1.176	1.2	1.224	V	①
Operating Voltage Range	Vin		2	—	6	V	①
Maximum Output Current	Iout.max	VIN=2.5V	500	—	—	mA	①
U.V.L.O . Voltage	Vuvlo	Vce=Vin, Vout=0V, LX Voltage which Lx pin voltage holding "L" level	1	1.4	1.78	V	②
Supply Current	Idd	Vin=Vce=3.0V, Vout=Vout×1.1	—	60	120	uA	③
Stand-by Current	Istb	Vin=3.0V, Vce=0V, Vout=Vout×1.1	—	0	1	uA	③
Frequency	FOSC	Iout=100mA	1020	1200	1380	KHz	①
PFM Switch Current	Ipfm	Vce=Vin, Iout=1mA	100	140	180	mA	①
Maximum Duty Ratio	Maxdty	Vce=Vin, Vout=0	100	—	—	%	④
Minimum Duty Ratio	Mindty	Vce=Vout=Vin	—	—	0	%	④
Efficiency	EFFI	Vce=Vin=2.5V, Iout=100mA	—	90	—	%	①
Lx SW "H" ON Resistance	RlxH	Vce=0.5Vin, Vce=0V, Ilix=100mA	—	0.5	1.2	Ω	⑤
Lx SW "L" ON Resistance	RlxL	Vce=0.5Vin, Ilix=100mA	—	0.6	1.4	Ω	—
Lx SW "H" Leak Current	IleakH	Vin=Vout=5.0V, Vce=0V, Lx=0V	—	0.01	1	uA	⑥
Lx SW "L" Leak Current	IleakL	Vin=Vout=5.0V, Vce=0V, Lx=5V	—	0.01	1	uA	⑥
Current Limit	Ilim	Vin=Vce=5.0V, Vout=0V	600	700	—	mA	⑦
Output Voltage Temperature Characteristics	Vout/ (Vout* Δtopr)	Iout=30mA, -40°C≤Topr≤85°C	—	+100	—	ppm/°C	①
CE "H" Voltage	VceH	Vout=0V	0.9	—	Vin	V	⑧
CE "L" Voltage	VceL	Vout=0V	Vss	—	0.3	V	⑧
CE "H" Current	Iceh	Vin=Vce=5.5V, Vout=0V	-0.1	—	0.1	uA	⑧
CE "L" Current	Icel	Vin=5.5V, Vce=0V, Vout=0V	-0.1	—	0.1	uA	⑧
Soft-Start Time	Tss	Vce=0V~Vin, Iout=1mA	0.5	1.0	3.0	msec	①
Latch Time	Tlat	Vin=Vce=5.0V	1	—	20	msec	⑨

ME3101A18 (Unless Otherwise Stated ,VIN=3.6V, FOSC=1.2MHz, Cin=4.7uF, CL=10uF, L=3.3uH, Ta=25°C)

PARAMETER	SYMBOL	CONDITIONS	MIN.	TYP.	MAX.	UNIT	CIRCUIT
Output Voltage	Vout	Vce=Vin, Iout=30mA	1.764	1.8	1.836	V	①
Operating Voltage Range	Vin		2	—	6	V	①
Maximum Output Current	Iout.max	VIN=3.0V	500	—	—	mA	①
U.V.L.O . Voltage	Vuvlo	Vce=Vin, Vout=0V, LX Voltage which Lx pin voltage holding "L" level	1	1.4	1.78	V	②
Supply Current	Idd	Vin=Vce=3.6V, Vout=Vout×1.1	—	60	120	uA	③
Stand-by Current	Istb	Vin=3.6V, Vce=0V, Vout=Vout×1.1	—	0	1	uA	③
Frequency	FOSC	Iout=100mA	1020	1200	1380	KHz	①
PFM Switch Current	Ipfm	Vce=Vin, Iout=1mA	100	140	180	mA	①
Maximum Duty Ratio	Maxdty	Vce=Vin, Vout=0	100	—	—	%	④
Minimum Duty Ratio	Mindty	Vce=Vout=Vin	—	—	0	%	④
Efficiency	EFFI	Vce=Vin=3.0V, Iout=100mA	—	90	—	%	①
Lx SW "H" ON Resistance	RlxH	Vce=0.5Vin, Vce=0V, Iix=100mA	—	0.5	1.2	Ω	⑤
Lx SW "L" ON Resistance	RlxL	Vce=0.5Vin, Iix=100mA	—	0.6	1.4	Ω	—
Lx SW "H" Leak Current	IleakH	Vin=Vout=5.0V, Vce=0V, Lx=0V	—	0.01	1	uA	⑥
Lx SW "L" Leak Current	IleakL	Vin=Vout=5.0V, Vce=0V, Lx=5V	—	0.01	1	uA	⑥
Current Limit	Ilim	Vin=Vce=5.0V, Vout=0V	600	700	—	mA	⑦
Output Voltage Temperature Characteristics	Vout/ (Vout* Δtopr)	Iout=30mA, -40°C≤Topr≤85°C	—	+100	—	ppm/°C	①
CE "H" Voltage	VceH	Vout=0V	0.9	—	Vin	V	⑧
CE "L" Voltage	VceL	Vout=0V	Vss	—	0.3	V	⑧
CE "H" Current	Iceh	Vin=Vce=5.5V, Vout=0V	-0.1	—	0.1	uA	⑧
CE "L" Current	Icel	Vin=5.5V, Vce=0V, Vout=0V	-0.1	—	0.1	uA	⑧
Soft-Start Time	Tss	Vce=0V~Vin, Iout=1mA	0.5	1.0	3.0	msec	①
Latch Time	Tlat	Vin=Vce=5.0V	1	—	20	msec	⑨

ME3101A33 (Unless Otherwise Stated ,VIN=5V, FOSC=1.2MHz, Cin=4.7uF, CL=10uF, L=3.3uH, Ta=25°C)

PARAMETER	SYMBOL	CONDITIONS	MIN.	TYP.	MAX.	UNIT	CIRCUIT
Output Voltage	Vout	Vce=Vin, Iout=30mA	3.234	3.3	3.366	V	①
Operating Voltage Range	Vin		2	—	6	V	①
Maximum Output Current	Iout.max	VIN=4.5V	500	—	—	mA	①
U.V.L.O . Voltage	Vuvlo	Vce=Vin, Vout=0V, LX Voltage which Lx pin voltage holding "L" level	1	1.4	1.78	V	②
Supply Current	Idd	Vin=Vce=5V, Vout=Vout×1.1	—	60	120	uA	③
Stand-by Current	Istb	Vin=5V, Vce=0V, Vout=Vout×1.1	—	0	1	uA	③
Frequency	FOSC	Iout=100mA	1020	1200	1380	KHz	①
PFM Switch Current	Ipfm	Vce=Vin, Iout=1mA	100	140	180	mA	①
Maximum Duty Ratio	Maxdty	Vce=Vin, Vout=0	100	—	—	%	④
Minimum Duty Ratio	Mindty	Vce=Vout=Vin	—	—	0	%	④
Efficiency	EFFI	Vce=Vin=4.5V, Iout=100mA	—	93	—	%	①
Lx SW "H" ON Resistance	RlxH	Vce=0.5Vin, Vce=0V, Iix=100mA	—	0.5	1.2	Ω	⑤
Lx SW "L" ON Resistance	RlxL	Vce=0.5Vin, Iix=100mA	—	0.6	1.4	Ω	—
Lx SW "H" Leak Current	IleakH	Vin=Vout=5.0V, Vce=0V, Lx=0V	—	0.01	1	uA	⑥
Lx SW "L" Leak Current	IleakL	Vin=Vout=5.0V, Vce=0V, Lx=5V	—	0.01	1	uA	⑥
Current Limit	Ilim	Vin=Vce=5.0V, Vout=0V	600	700	—	mA	⑦
Output Voltage Temperature Characteristics	Vout/ (Vout* Δtopr)	Iout=30mA, -40°C≤Topr≤85°C	—	±100	—	ppm/°C	①
CE "H" Voltage	VceH	Vout=0V	1.1	—	Vin	V	⑧
CE "L" Voltage	VceL	Vout=0V	Vss	—	0.3	V	⑧
CE "H" Current	Iceh	Vin=Vce=5.5V, Vout=0V	-0.1	—	0.1	uA	⑧
CE "L" Current	Icel	Vin=5.5V, Vce=0V, Vout=0V	-0.1	—	0.1	uA	⑧
Soft-Start Time	Tss	Vce=0V~Vin, Iout=1mA	0.5	1.0	3.0	msec	①
Latch Time	Tlat	Vin=Vce=5.0V	1	—	20	msec	⑨

Note On Use:

1. Use Ceramic Capacitor will achieve low ripple and high efficiency.
2. When the difference between VIN and VOUT is large in PWM control, very narrow pulses will be outputted, and there is the possibility that some cycles may be skipped completely.
3. When the difference between VIN and VOUT is small, and the load current is heavy, very wide pulses will be outputted and there is the possibility that some cycles may be skipped completely: in this case, the Lx pin may not go low at all.
4. With the IC, the peak current of the coil is controlled by the current limit circuit. Since the peak current increases when dropout voltage or load current is high, current limit starts operating, and this can lead to instability. When peak current becomes high, please adjust the coil inductance value and fully check the circuit operation. In addition, please calculate the peak current according to the following formula:
$$I_{pk} = (VIN - VOUT) * \text{On Duty} / (2 * L * FOSC) + I_{OUT}$$

L: Coil Inductance Value
FOSC: Oscillation Frequency
5. When VIN is less than 2.4V, limit current may not be reached because voltage falls caused by ON resistance.
6. Care must be taken when laying out the PC Board, in order to prevent misoperation of the current limit mode. Depending on the state of the PC Board, latch time may become longer and latch operation may not work. In order to avoid the effect of noise, the board should be laid out so that capacitors are placed as close to the chip as possible.
7. Use of the IC at voltages below the recommended voltage range may lead to instability.
8. When the IC is used in high temperature, output voltage may increase up to input voltage level at no load because of the leak current of the driver transistor.

Typical Performance Characteristics:

(1) Efficiency vs. Output Current

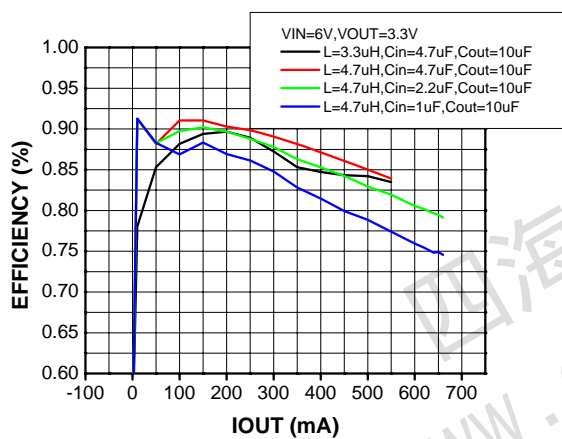
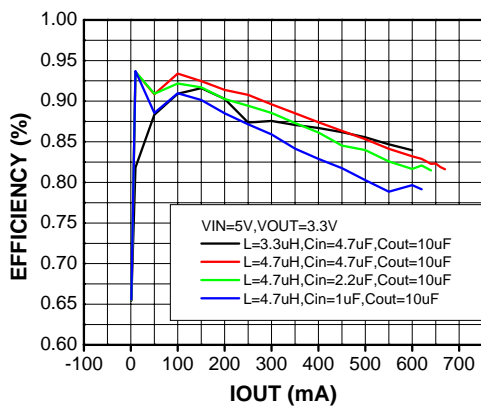
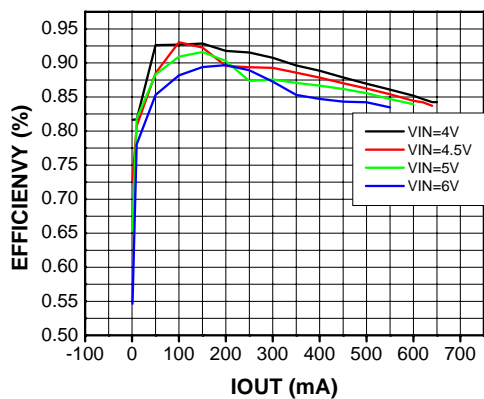

(2) Output Voltage vs. Output Current

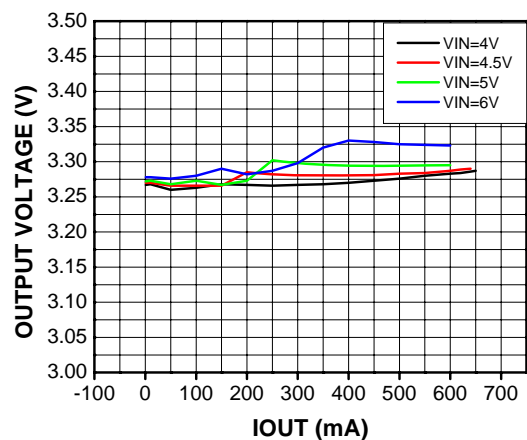

(3) Input Current vs. Output Current

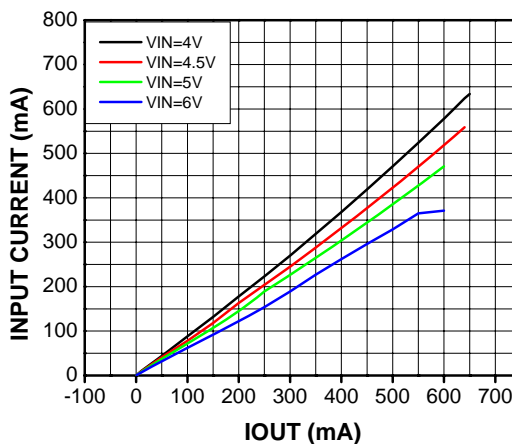

(4) Linear Transient Response Time

R=33Ω, IOUT=100mA, VIN=0~5V

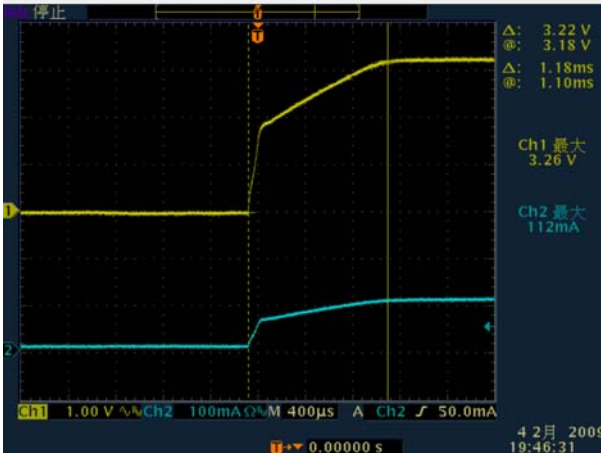

R=11Ω, IOUT=300mA, VIN=0~5V

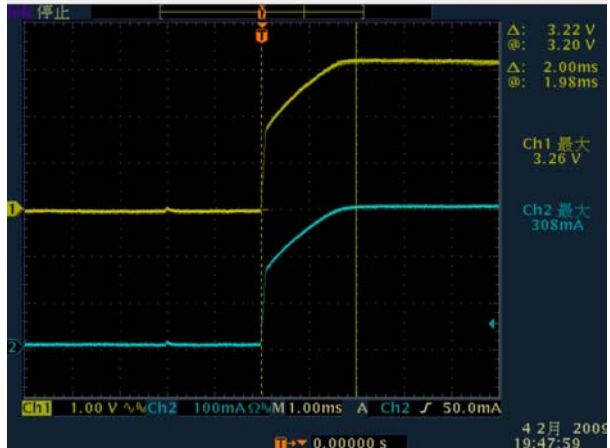

R=6Ω, IOUT=550mA, VIN=0~5V

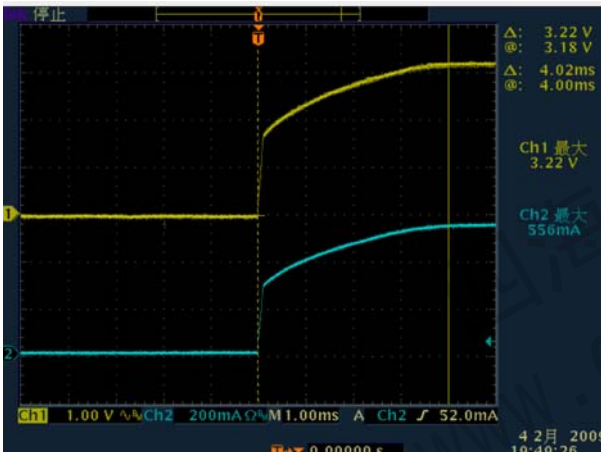

四海恒通科技
gofotech.com

(5) Load Response

VIN=5V, IOUT=0~100mA

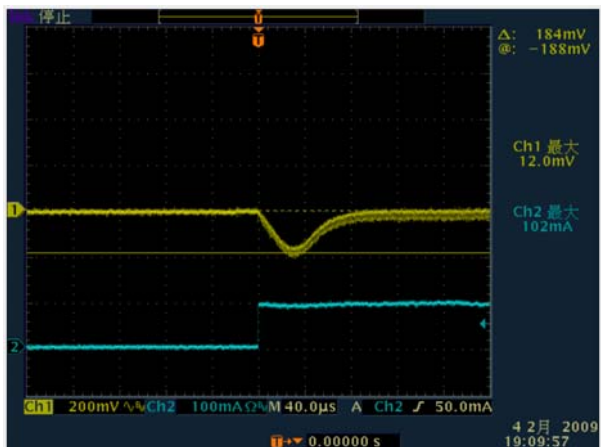

VIN=5V, IOUT=100~0mA

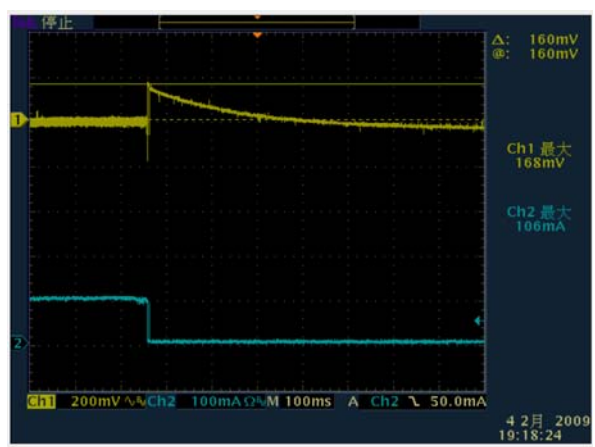

VIN=5V,IOUT=0~300mA

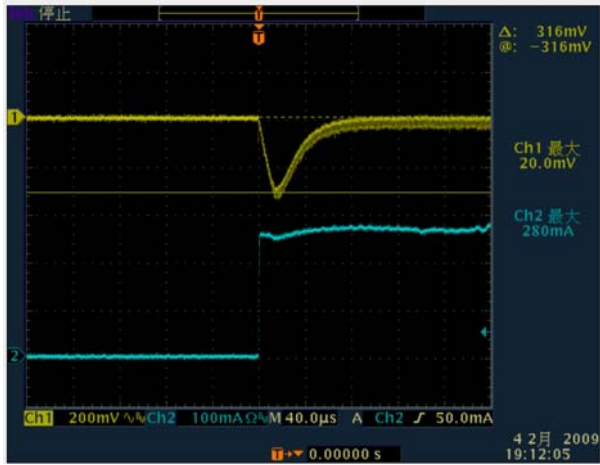

VIN=5V,IOUT=300~0mA

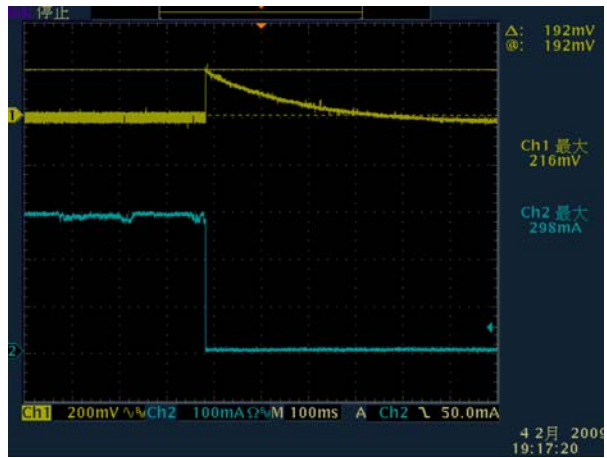

VIN=5V,IOUT=0~550mA

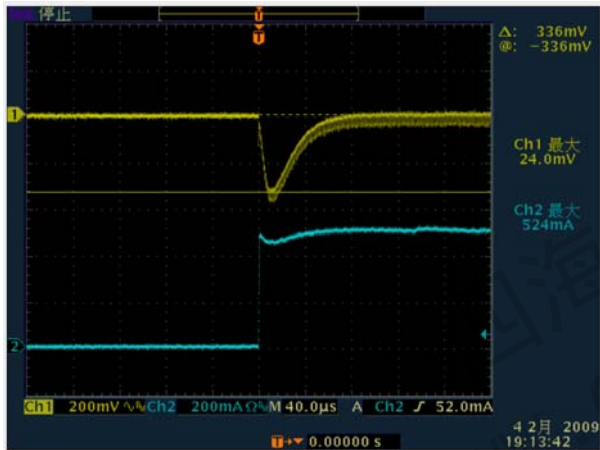

VIN=5V,IOUT=550~0mA

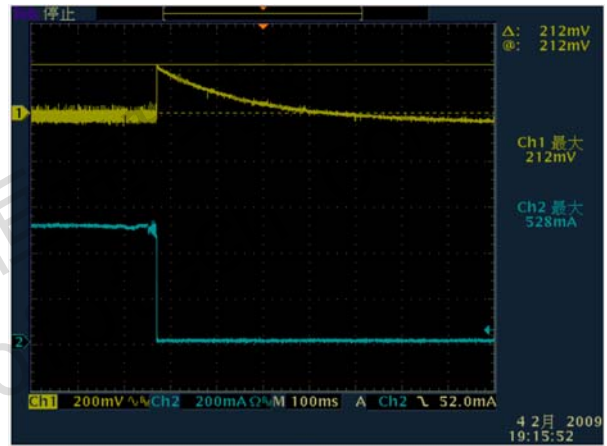

Test Circuit:

Circuit ①

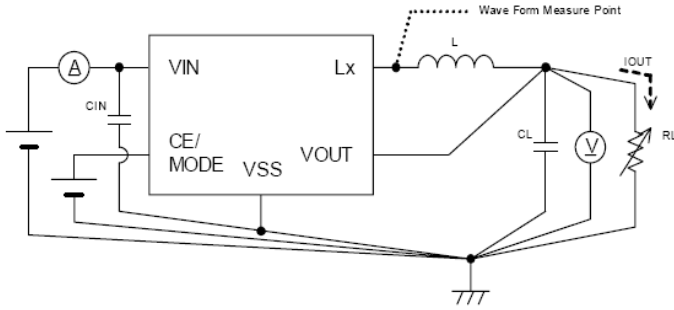

Circuit ②

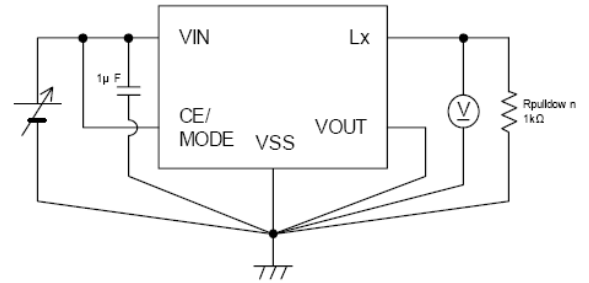

Circuit ③

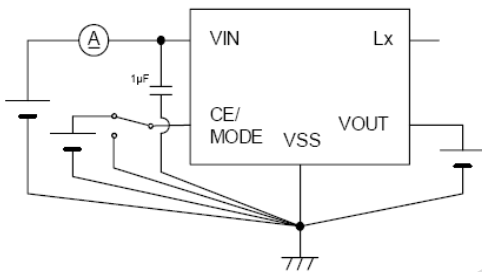

Circuit ④

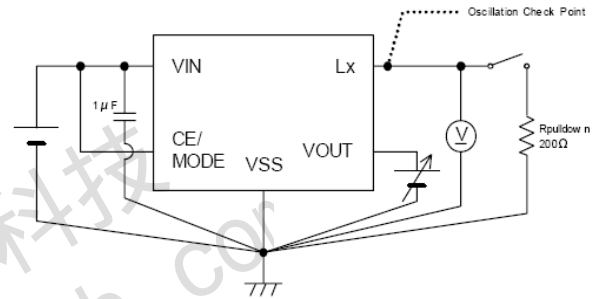

Circuit ⑤

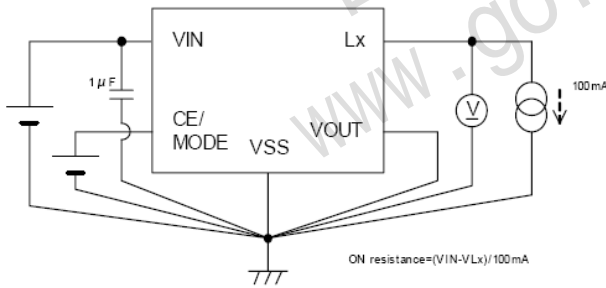

Circuit ⑥

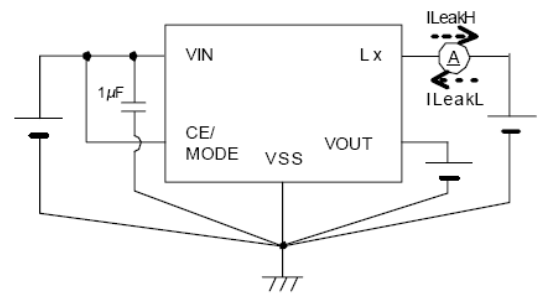

Circuit ⑦

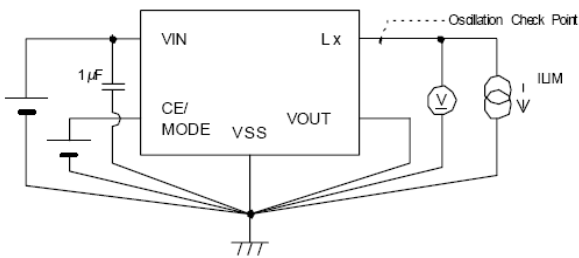

Circuit ⑧

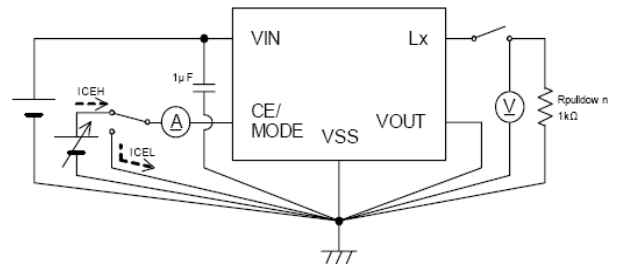

Circuit ⑨

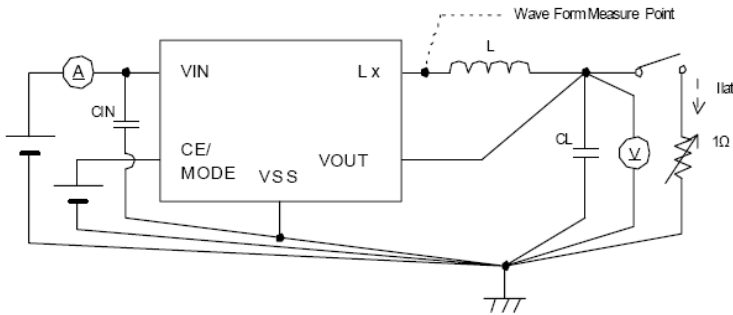

Package Information:

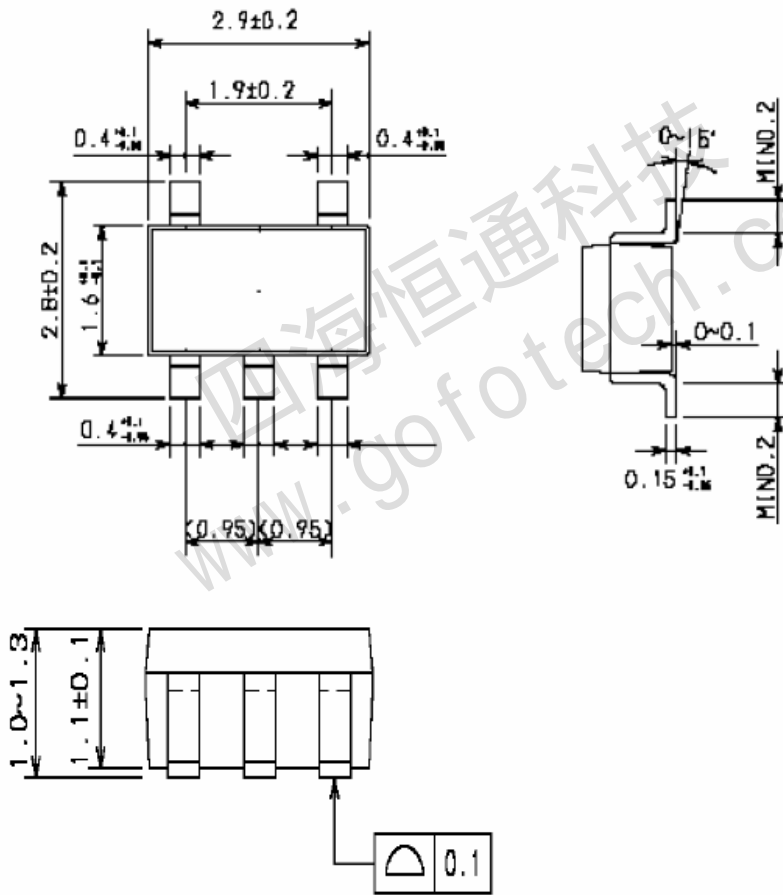

SOT-23-5L

- The information described herein is subject to change without notice.
- Nanjing Micro One Electronics Inc is not responsible for any problems caused by circuits or diagrams described herein whose related industrial properties, patents, or other rights belong to third parties. The application circuit examples explain typical applications of the products, and do not guarantee the success of any specific mass-production design.
- Use of the information described herein for other purposes and/or reproduction or copying without the express permission of Nanjing Micro One Electronics Inc is strictly prohibited.
- The products described herein cannot be used as part of any device or equipment affecting the human body, such as exercise equipment, medical equipment, security systems, gas equipment, or any apparatus installed in airplanes and other vehicles, without prior written permission of Nanjing Micro One Electronics Inc.
- Although Nanjing Micro One Electronics Inc exerts the greatest possible effort to ensure high quality and reliability, the failure or malfunction of semiconductor products may occur. The user of these products should therefore give thorough consideration to safety design, including redundancy, fire-prevention measures, and malfunction prevention, to prevent any accidents, fires, or community damage that may ensue.