

CRYSTAL CONTROLLED OSCILLATORS

5.0V SURFACE MOUNT 11x6.35mm HCMOS CLOCK OSCILLATOR



HSM626, HSM636

ABSOLUTE MAXIMUM RATINGS

TABLE 1.0

PARAMETER	UNITS	MINIMUM	NOMINAL	MAXIMUM	UNITS	NOTE
Storage Temperature		-55	-	125	°C	
Supply Voltage	(Vcc)	-0.5	-	7.0	Vdc	

MODEL SPECIFICATIONS:

TABLE 2.0

MODEL HSM626						
Frequency Range	(Fo)	1.8	-	80	MHz	
Frequency Tolerance:		-50	-	50	ppm	1
MODEL HSM636						
Frequency Range	(Fo)	1.8	-	80	MHz	
Frequency Tolerance:		-100	-	100	ppm	1

OPERATING SPECIFICATIONS

TABLE 3.0

PARAMETER		MINIMUM	NOMINAL	MAXIMUM	UNITS	NOTE
Operating Temperature Range		-40	-	85	°C	
Supply Voltage	(Vdd)	4.5	5.0	5.5	Vdc	
Supply Current	1.8 to 19.999 MHz	(Icc)	-	20	mA	
	20 to 49.999 MHz	(Icc)	-	30	mA	
	50 to 69.999 MHz	(Icc)	-	50	mA	
	70 to 80.0 MHz	(Icc)	-	80	mA	

INPUT CHARACTERISTICS

TABLE 4.0

Enable Voltage	(Vih)	2.2	-	-	Vdc	2
Disable Voltage	(Vil)	-	-	.08	Vdc	
Enable Time		-	-	100	nS	
Disable Time		-	-	100	nS	

HCMOS OUTPUT CHARACTERISTICS

TABLE 5.0

PARAMETER		MINIMUM	NOMINAL	MAXIMUM	UNITS	NOTE
LOAD		-	-	50	pF	
Voltage	(High)	(Voh)	4.50	-	Vdc	
	(Low)	(Vol)	-	0.50	Vdc	
Current	(High)	(Ioh)	-16	-	mA	
	(Low)	(Iol)	-	16	mA	
Duty Cycle at 50% of Vcc		45	50	55	%	
Rise / Fall Time 10% to 90%		-	-	5	nS	
Start-Up Time		-	-	10	mS	
Jitter (BW=10Hz to 20MHz)		-	-	5	ps rms	
Jitter (BW=12kHz to 20MHz)		-	-	1	ps rms	

PACKAGE CHARACTERISTICS

TABLE 6.0

Package	Hermetically sealed ceramic package and metal cover
---------	---

Note:

- Inclusive of calibration @ 25°C, frequency vs. temperature stability, supply voltage change, load change, shock and vibration, 10 years aging.
- Oscillator output is enabled with no connection on pad 1

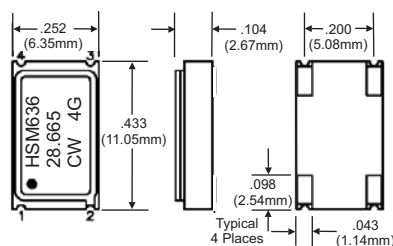

PAD	CONNECTION
1	ENABLE/DISABLE
2	GROUND
3	OUTPUT
4	Vcc

Dimensional Tolerance: ±.02" (.508mm)
±.005" (.127mm)

DESCRIPTION

The Connor-Winfield models HSM626 and HSM636 are 5.0V HCMOS, Surface Mount, Fixed Frequency Crystal Oscillators (XO) designed for use in all applications requiring precision clocks over the -40 to 85°C, Commercial Temperature Range. The surface mount package is designed for high-density mounting and is optimum for mass production.

FEATURES

- 1.8 to 80 MHz
- 5.0V OPERATION
- TRI-STATE ENABLE / DISABLE FUNCTION
- OVERALL FREQUENCY TOLERANCE:
HSM626 ±50ppm
HSM636 ±100ppm
- TEMPERATURE RANGE: -40 to 85°C
- CERAMIC SURFACE MOUNT PACKAGE
- TAPE AND REEL PACKAGING
- RoHS COMPLIANT / Pb FREE

ORDERING INFORMATION

HSM636 - 028.665M

CLOCK
SERIES

CENTER
FREQUENCY

CRYSTAL CONTROLLED OSCILLATORS

ENVIRONMENTAL CHARACTERISTICS

TEMPERATURE CYCLE:
The specimen shall meet electrical characteristics after tested 5 cycles of -55°C/30 min & +125°C/30 min.

HERMETICAL
No bubbles appear in Flourinert (FC-43) at 125°C ±5°C, for 5 minutes.

SOLVENT RESISTANCE:
Marking will withstand immersion in Isopropyl Alcohol or Trichloroethylene.

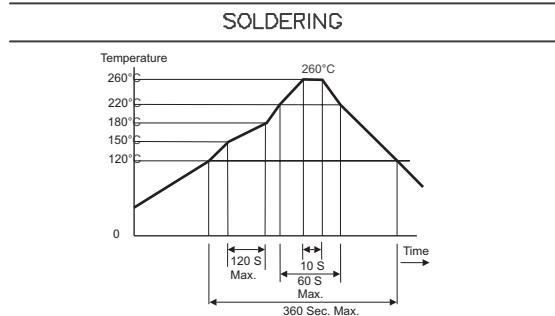

MECHANICAL CHARACTERISTICS

FREE DROP:
The specimen shall meet electrical characteristics after tested 3 times Free Drop testing on the hard wooden board from a height of 75cm.

VIBRATION:
The specimen shall meet electrical characteristics after tested by the following conditions:
10-5Hz 1.5mm Amplitude, 55-2000Hz 20G's, 2 hours for each plane.

THERMAL SHOCK:
After applied Thermal Shock of 260°C max x 10 sec max x 2 times, or 230°C max x 180 sec max, the specimen shall meet electrical characteristics.

SOLDERABILITY: (EIAJ-RGX-0102/1D1 Condition 1a)
1. Flux: MIL-F-14256 (WW Rosin=25%, Isopropyl alcohol=75%)
2. Solder: QQ-S-571 (Sn=63%, Pb=37%)
3. Solder bath temperature: 235°C ±5°C.
4. Depth of immersion: Up to electrical terminal.
5. Immersing time: Within 2 sec ±0.5 sec into solder bath.

After performing the above procedures, a newly soldered coverage shall be greater than 90%.

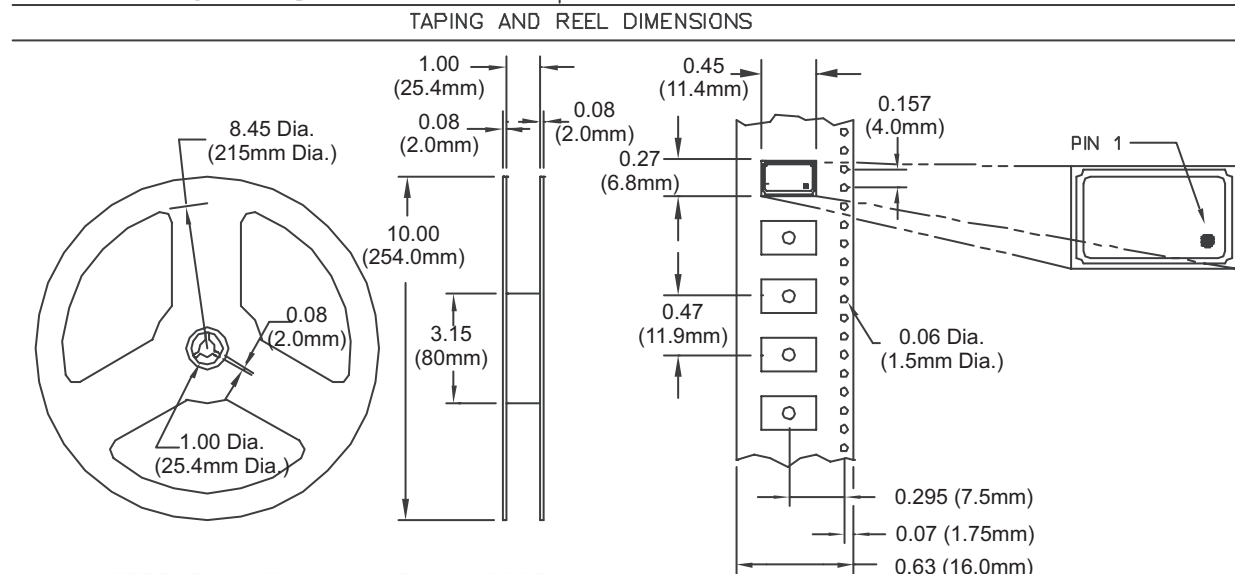
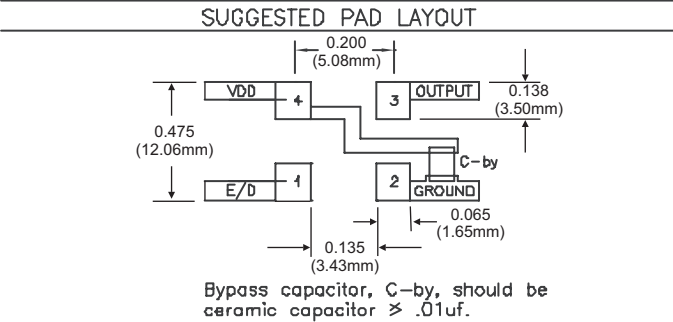
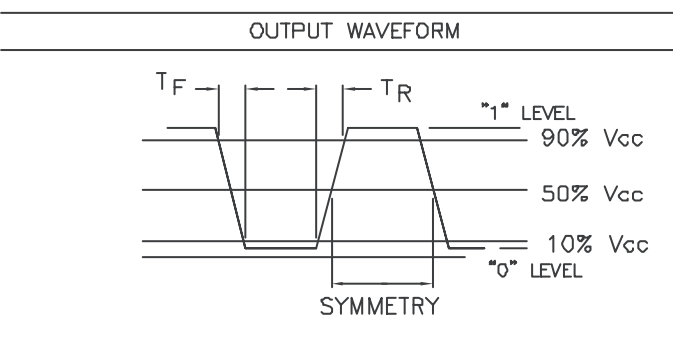
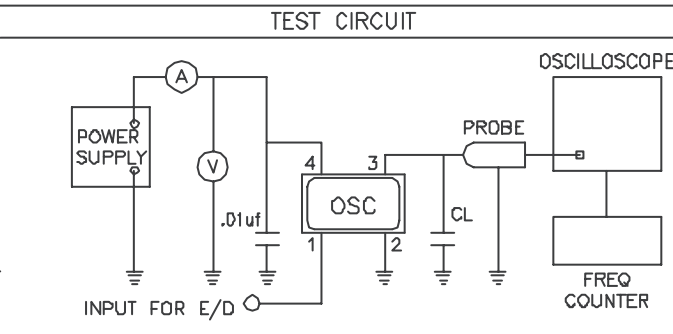

MEETS EIA-481A AND EIAJ-1009B
1000 PCS / REEL