

MB87001A

CMOS PLL FREQUENCY SYNTHESIZER

3

CMOS SERIAL INPUT PHASE-LOCKED-LOOP (PLL) FREQUENCY SYNTHESIZER

The Fujitsu MB87001A, fabricated in CMOS technology, is a serial input PLL frequency synthesizer.

The MB87001A contains an inverter for connection to an external oscillator, a programmable reference divider, a phase detector, a charge pump, a 17-bit shift register, a 17-bit latch, a programmable divider (a binary 7-bit swallow counter, a binary 10-bit programmable counter), and a control generator for an external dual modulus prescaler.

When supplemented with a loop filter and VCO, the MB87001A contains the necessary circuitry to make up a Phase Locked Loop (PLL). Typically, a dual modulus prescaler such as the MB501L can be added, allowing input frequency operation up to 1.1 GHz.

- Single power supply voltage:
V_{DD} = 2.7V to 5.5V
- Wide temperature range:
T_A = -40 to 85°C
- 13MHz typical input capability
@5V (fin input)
- On-chip inverter for oscillator
- 8 divide factors for programmable reference divider is selected by S₁.
- S₂ and S₃ input (1/8, 1/16, 1/64, 1/128, 1/256, 1/512, 1/1024, 1/2048)
- Programmable 17-bit divider with input amplifier consisting of:
Binary 7-bit swallow counter
Binary 10-bit programmable counter
- 2 type of phase detector output
On-chip charge pump output
Output for external charge pump
- Easy interface to Fujitsu dual modulus prescaler

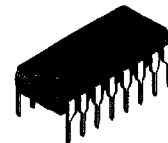

PLASTIC PACKAGE
DIP-16P-M04

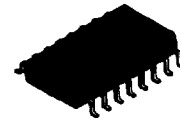

PLASTIC PACKAGE
FPT-16P-M06

ABSOLUTE MAXIMUM RATINGS (see NOTE)

(V_{SS} = 0V)

Rating	Symbol	Value	Unit
Power Supply Voltage	V _{DD}	V _{SS} -0.5 to V _{SS} +7.0	V
Input Voltage	V _{IN}	V _{SS} -0.5 to V _{DD} +0.5	V
Output Voltage	V _{OUT}	V _{SS} -0.5 to V _{DD} +0.5	V
Output Current	I _{OUT}	±10	mA
Open-drain Output	V _{OOP}	V _{SS} -0.5 to V _{DD} +3.0	V
Operating Temperature	T _A	-40 to +85	°C
Storage Temperature	T _{STG}	-65 to +150	°C
Power Dissipation	P _D	300	mW

NOTE: Permanent device damage may occur if the above **Absolute Maximum Ratings** are exceeded. Functional operation should be restricted to the conditions as detailed in the operational sections of this data sheet. Exposure to absolute maximum rating conditions for extended periods may affect device reliability.

PIN ASSIGNMENT

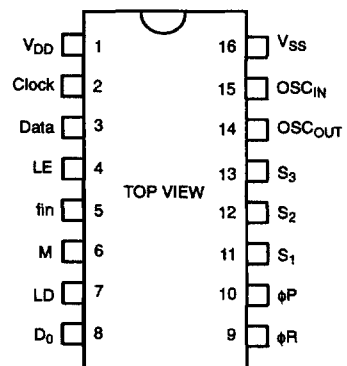

This device contains circuitry to protect the inputs against damage due to high static voltages or electric fields. However, it is advised that normal precautions be taken to avoid application of any voltage higher than maximum rated voltages to this high impedance circuit.

Fig. 1 – MB87001A BLOCK DIAGRAM

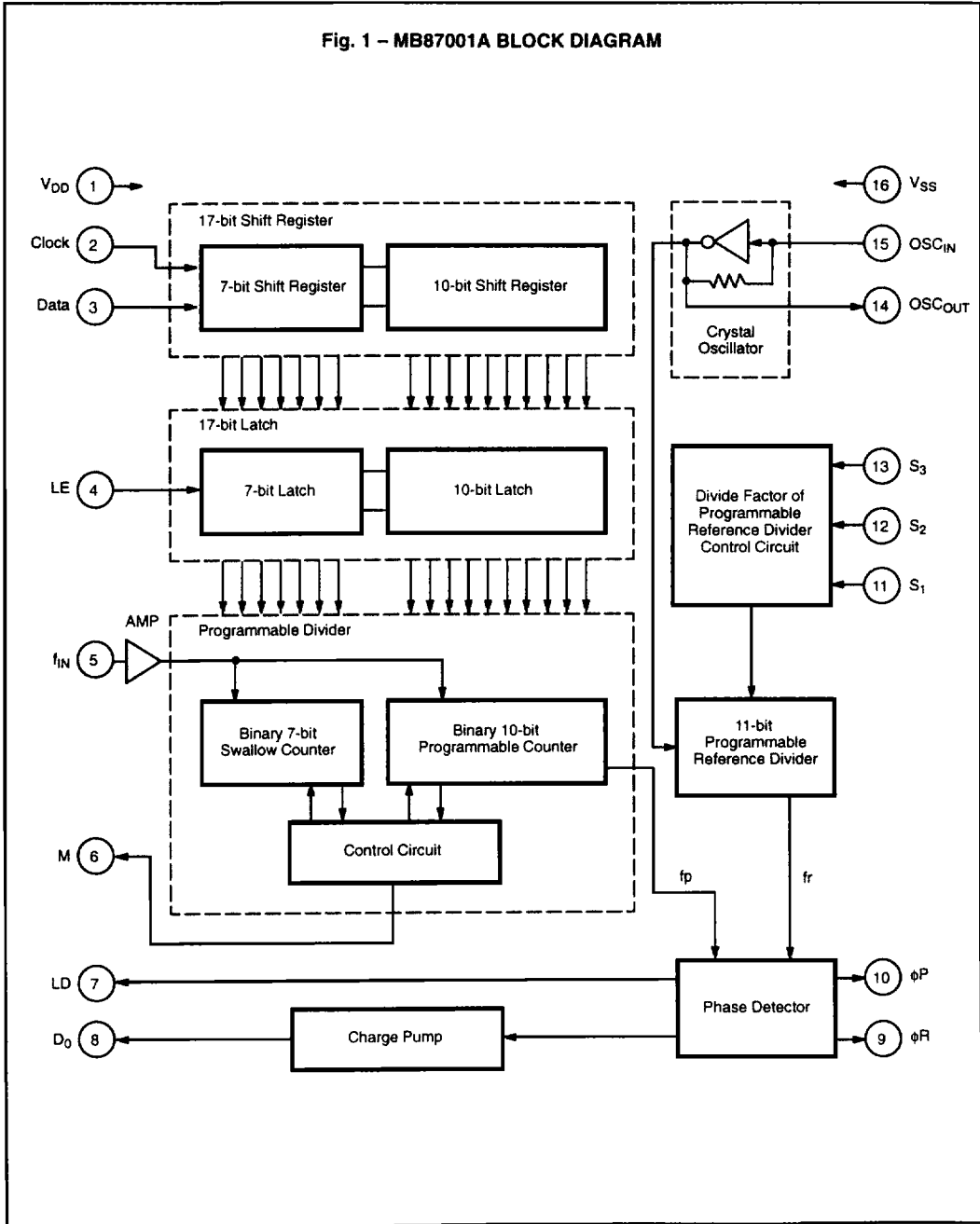

PIN DESCRIPTION

3

Pin No.	Pin Name	I/O	Description																																				
1	V _{DD}	–	Power supply voltage input																																				
2	Clock	I	Clock signal input for 17-bit shift register Each rising edge of the clock shifts one bit of the data into the shift register																																				
3	Data	I	Serial data input for 17-bit shift register The data is used for setting the divide factor of the programmable divider																																				
4	LE	I	Load enable input When this pin is high level (high active), the data stored in the 17-bit shift register is transferred to the 17-bit latch.																																				
5	f _{IN}	I	Input for programmable divider from VCO or prescaler output This input involves the bias circuit and amplifier. The connection with the external dual modulus prescaler should be an AC connection.																																				
6	M	O	Control output for external dual modulus prescaler The connection to the prescaler should be a DC connection. This output level is synchronized with the falling edge of the f _{IN} input signal (pin #5). Pulse Swallow Function: MB501L M = High: Preset modulus factor 64 or 128 M = Low: Preset modulus factor 65 or 129																																				
7	LD	O	Output of phase detector It is high level when fr and fp are equal, and then the loop is locked. Otherwise it outputs a negative pulse signal.																																				
8	D _O	O	Three-state charge pump output of the phase detector The mode of D _O is changed by the combination of the programmable reference divider output frequency (fr) and the programmable divider output frequency (fp) as listed below: fr > fp: Drive mode (D _O = High level) fr = fp: High-impedance mode fr < fp: Sink mode (D _O = Low level)																																				
9	φR	O	Phase detector outputs for an external charge pump The mode of φR and φP are changed by the combination of the programmable reference divider output frequency (fr) and the programmable divider output frequency (fp) as listed below: φR φP fr > fp: Low Low fr = fp: Low High-Impedance fr < fp: High High-Impedance * φP is a N-channel open drain output																																				
10	φP	O																																					
11	S ₁	I	Control input for programmable reference divider The combination of these inputs provides 8 kinds of divide factor for the programmable reference divider.																																				
12	S ₂	I																																					
13	S ₃	I																																					
			<table border="1"> <thead> <tr> <th>Divide Factor \ S_n</th> <th>1/8</th> <th>1/16</th> <th>1/64</th> <th>1/128</th> <th>1/256</th> <th>1/512</th> <th>1/1024</th> <th>1/2048</th> </tr> </thead> <tbody> <tr> <th>S₁</th> <td>0</td> <td>1</td> <td>0</td> <td>1</td> <td>0</td> <td>1</td> <td>0</td> <td>1</td> </tr> <tr> <th>S₂</th> <td>0</td> <td>0</td> <td>1</td> <td>1</td> <td>0</td> <td>0</td> <td>1</td> <td>1</td> </tr> <tr> <th>S₃</th> <td>0</td> <td>0</td> <td>0</td> <td>0</td> <td>1</td> <td>1</td> <td>1</td> <td>1</td> </tr> </tbody> </table>	Divide Factor \ S _n	1/8	1/16	1/64	1/128	1/256	1/512	1/1024	1/2048	S ₁	0	1	0	1	0	1	0	1	S ₂	0	0	1	1	0	0	1	1	S ₃	0	0	0	0	1	1	1	1
Divide Factor \ S _n	1/8	1/16	1/64	1/128	1/256	1/512	1/1024	1/2048																															
S ₁	0	1	0	1	0	1	0	1																															
S ₂	0	0	1	1	0	0	1	1																															
S ₃	0	0	0	0	1	1	1	1																															
14	OSC _{OUT}	O	Output pin for crystal oscillator Output of the inverting amplifier This pin should be open when an external oscillator is used.																																				
15	OSC _{IN}	I	Input pin for crystal oscillator. Input to the inverting amplifier that forms part of the oscillator This pin receives the oscillator signal as AC coupled when an external oscillator is used. For large amplitude signals (standard CMOS levels) DC coupling may also be used.																																				
16	V _{SS}	–	Ground																																				

FUNCTIONAL DESCRIPTION

DIVIDE FACTOR OF PROGRAMMABLE DIVIDER

Serial data of binary code is input to the Data pin. These data are loaded into the 17-bit shift register from the MSB. When the load enable signal (LE) is high, the data stored in the 17-bit shift register is transferred to the 17-bit latch.

The data ① to ⑦ set a divide factor of the binary 7-bit swallow counter and data ⑧ to ⑰ set a divide factor of the binary 10-bit programmable counter. In other words, serial data is equivalent to the divide factor of programmable divider.

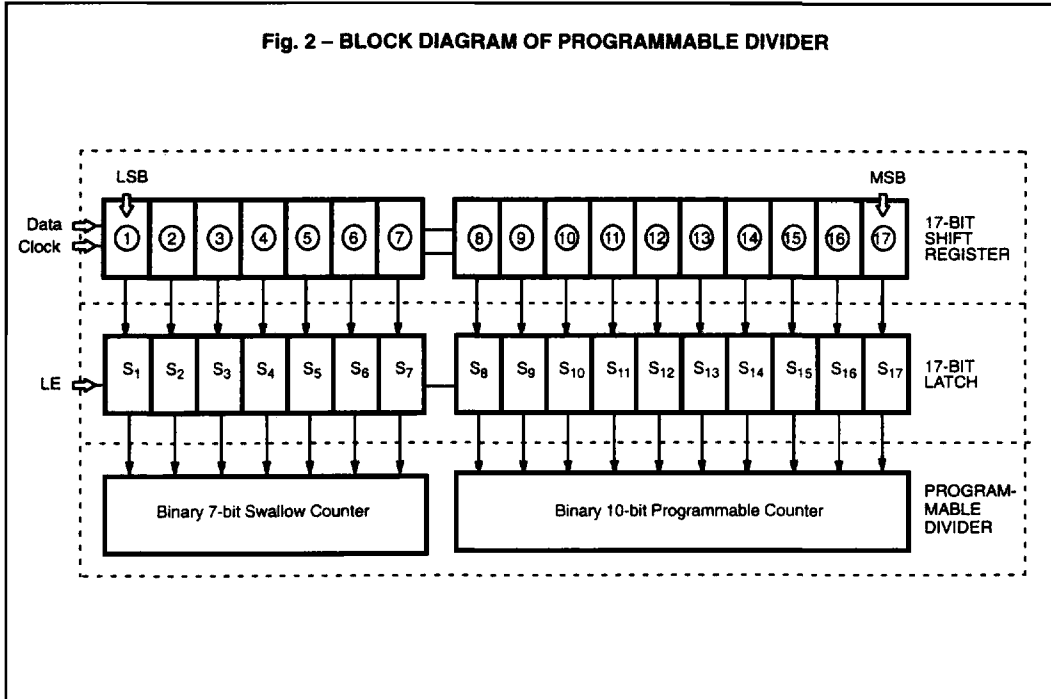

Binary 7-bit Swallow Counter Data Input

⑦	⑥	⑤	④	③	②	①	Divide Factor A
0	0	0	0	0	0	0	0
0	0	0	0	0	0	1	1
0	0	0	0	0	1	0	2
0	0	0	0	0	1	1	3
0	0	0	0	1	0	0	4
.
1	1	1	1	1	1	1	127

3

Note: Divide factor A: 0 to 127
 Depending upon the divide factor set input (SW) of external prescaler, the input data should be as follows:
 Example MB501L
 SW = H (64/65): Bit 7 of shift register (7) should be zero

Binary 10-bit Programmable Counter Data Input

⑰	⑱	⑮	⑭	⑬	⑫	⑪	⑩	⑨	⑧	Divide Factor N
0	0	0	0	0	0	0	1	0	1	5
0	0	0	0	0	0	0	1	1	0	6
0	0	0	0	0	0	0	1	1	1	7
.
1	1	1	1	1	1	1	1	1	1	1023

Note: Divide factor less than 5 is prohibited
 Divide factor N: 5 to 1023

PULSE SWALLOW FUNCTION

$$f_{VCO} = [(N \times M) + A] \times f_r$$

- f_{VCO} : Output frequency of external voltage controlled oscillator (VCO)
- N : Preset divide factor of binary 10-bit programmable counter (5 to 1023)
- M : Preset modulus factor of external dual modulus prescaler (e.g. 64 in 64/65 mode, 128 in 128/129 mode of an MB501L prescaler)
- A : Preset divide factor of binary 7-bit swallow counter (0 to 127)
- f_r : Output frequency of the programmable reference divider

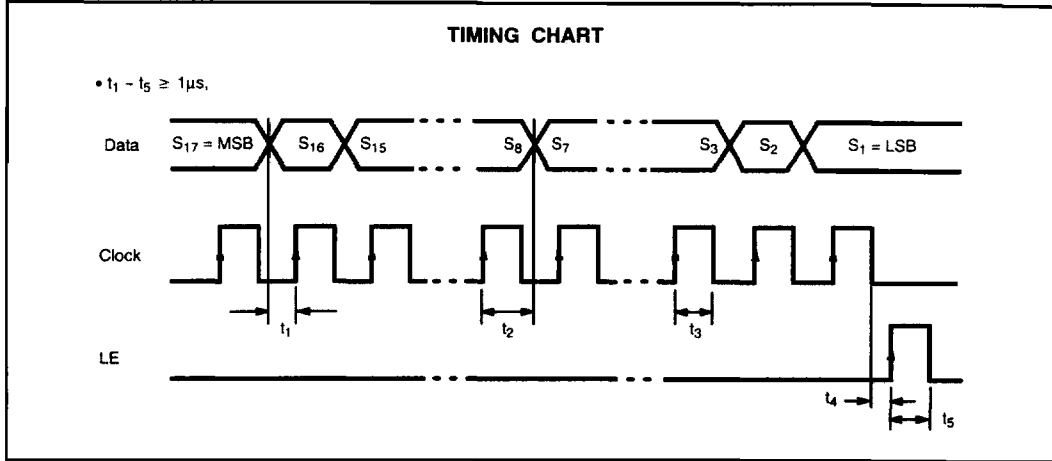

Clock : Clock signal input for the 17-bit shift register

Each rising edge of the clock shifts one bit of data into the shift register.

Data : Serial data input for the 17-bit shift register

LE : Load enable input

When LE is high (high active), the data stored in the 17-bit shift register is transferred to the 17-bit latch.

The 17-bit data is used for setting a divide factor of the programmable divider.

RECOMMENDED OPERATING CONDITIONS

(V_{SS} = 0V)

Parameter	Symbol	Value			Unit
		Min	Typ	Max	
Power Supply Voltage	V _{DD}	2.7	—	5.5	V
Input Voltage	V _{IN}	V _{SS}	—	V _{DD}	V
Operating Temperature	T _A	−40	—	+85	°C

HANDLING PRECAUTIONS

- This device should be transported and stored in anti-static containers.
- This is a static-sensitive device; take proper anti-ESD precautions. Ensure that personnel and equipment are properly grounded. Cover workbenches with grounded conductive mats.
- Always turn the power supply off before inserting or removing the device from its socket.
- Protect leads with a conductive sheet when handling or transporting PC boards with devices.

ELECTRICAL CHARACTERISTICS

(V_{DD} = 3.0V, V_{SS} = 0V, T_A = -40 to +85°C)

Parameter		Symbol	Condition	Value			Unit
				Min	Typ	Max	
High-level Input Voltage	Except f _{IN} and OSC _{IN}	V _{IH}	—	2.1	—	—	V
Low-level Input Voltage		V _{IL}	—	—	—	0.9	
Input Sensitivity	f _{IN}	V _{fIN}	Amplitude in AC coupling, sine wave	0.8	—	—	V _{p-p}
	OCS _{IN}	V _{OSC}		1.0	—	—	
High-level Input Current	Except f _{IN} and OSC _{IN}	I _{IH}	V _{IN} = V _{DD}	—	1.0	—	μA
Low-level Input Current		I _{IL}	V _{IN} = V _{SS}	—	-1.0	—	
Input Current	f _{IN}	I _{fIN}	V _{IN} = V _{SS} to V _{DD}	—	±30	—	μA
	OCS _{IN}	I _{OSC}		—	±30	—	
High-level Output Voltage	Except φP and OSC _{OUT}	V _{OH}	I _{OH} = 0μA	2.95	—	—	V
Low-level Output Voltage		V _{OL}	I _{OL} = 0μA	—	—	0.05	
Low-level Output Voltage	φP	V _{OLP}	I _{OL} = 0.8mA	—	—	0.8	V
High-level Output Voltage	OSC _{OUT}	V _{OHX}	I _{OH} = 0μA	2.50	—	—	
Low-level Output Voltage		V _{OLX}	I _{OL} = 0μA	—	—	0.50	
High-level Output Current	Except φP and OSC _{OUT}	I _{OH}	V _{OH} = 2.0V	-0.5	—	—	
Low-level Output Current		I _{OL}	V _{OL} = 0.8V	0.5	—	—	
N-channel Open Drain Cut Off Current	φP	I _{OFF}	V _O = V _{DD} +3.0V	—	1.0	—	μA
Power Supply Current*1		I _{DD}	—	—	2.0	—	mA
Max. Operating Frequency of Programmable Reference Divider		fMAXd	—	13	20	—	MHz
Max. Operating Frequency of Programmable Divider		fMAXp	—	10	20	—	MHz

Note: *1: f_{IN} = 5.0MHz, 12.8MHz crystal is connected between OSC_{IN} and OSC_{OUT}.
Inputs are connected to ground except for f_{IN} and OSC_{IN}. Outputs are open.

ELECTRICAL CHARACTERISTICS

 $(V_{DD} = 5.0V, V_{SS} = 0V, T_A = -40 \text{ to } +85^\circ\text{C})$

Parameter		Symbol	Condition	Value			Unit
				Min	Typ	Max	
High-level Input Voltage	Except f_{IN} and OSC_{IN}	V_{IH}	—	3.5	—	—	V
Low-level Input Voltage		V_{IL}	—	—	—	1.5	
Input Sensitivity	f_{IN}	V_{fIN}	Amplitude in AC coupling, sine wave	1.0	—	—	V_{P-P}
	OSC_{IN}	V_{OSC}		1.5	—	—	
High-level Input Current	Except f_{IN} and OSC_{IN}	I_{IH}	$V_{IN} = V_{DD}$	—	1.0	—	μA
Low-level Input Current		I_{IL}	$V_{IN} = V_{SS}$	—	-1.0	—	
Input Current	f_{IN}	I_{fIN}	$V_{IN} = V_{SS} \text{ to } V_{DD}$	—	± 50	—	μA
	OSC_{IN}	I_{OSC}		—	± 50	—	
High-level Output Voltage	Except ϕP and OSC_{OUT}	V_{OH}	$I_{OH} = 0\mu\text{A}$	4.95	—	—	V
Low-level Output Voltage		V_{OL}	$I_{OL} = 0\mu\text{A}$	—	—	0.05	
Low-level Output Voltage	ϕP	V_{OLP}	$I_{OL} = 0.8\text{mA}$	—	—	1.0	V
High-level Output Voltage	OSC_{OUT}	V_{OHX}	$I_{OH} = 0\mu\text{A}$	4.50	—	—	
Low-level Output Voltage		V_{OLX}	$I_{OL} = 0\mu\text{A}$	—	—	0.50	
High-level Output Current	Except ϕP and OSC_{OUT}	I_{OH}	$V_{OH} = 2.0V$	-1.0	—	—	
Low-level Output Current		I_{OL}	$V_{OL} = 0.8V$	1.0	—	—	
N-channel Open Drain Cut Off Current	ϕP	I_{OFF}	$V_O = V_{DD} + 3.0V$	—	1.0	—	μA
Power Supply Current*1		I_{DD}	—	—	2.0	—	mA
Max. Operating Frequency of Programmable Reference Divider		f_{MAXd}	—	15	25	—	MHz
Max. Operating Frequency of Programmable Divider		f_{MAXp}	—	13	25	—	MHz

Note: *1: $f_{IN} = 5.0\text{MHz}$, 12.8MHz crystal is connected between OSC_{IN} and OSC_{OUT} .
Inputs are connected to ground except for f_{IN} and OSC_{IN} . Outputs are open.

Fig. 3 - TYPICAL APPLICATION EXAMPLE

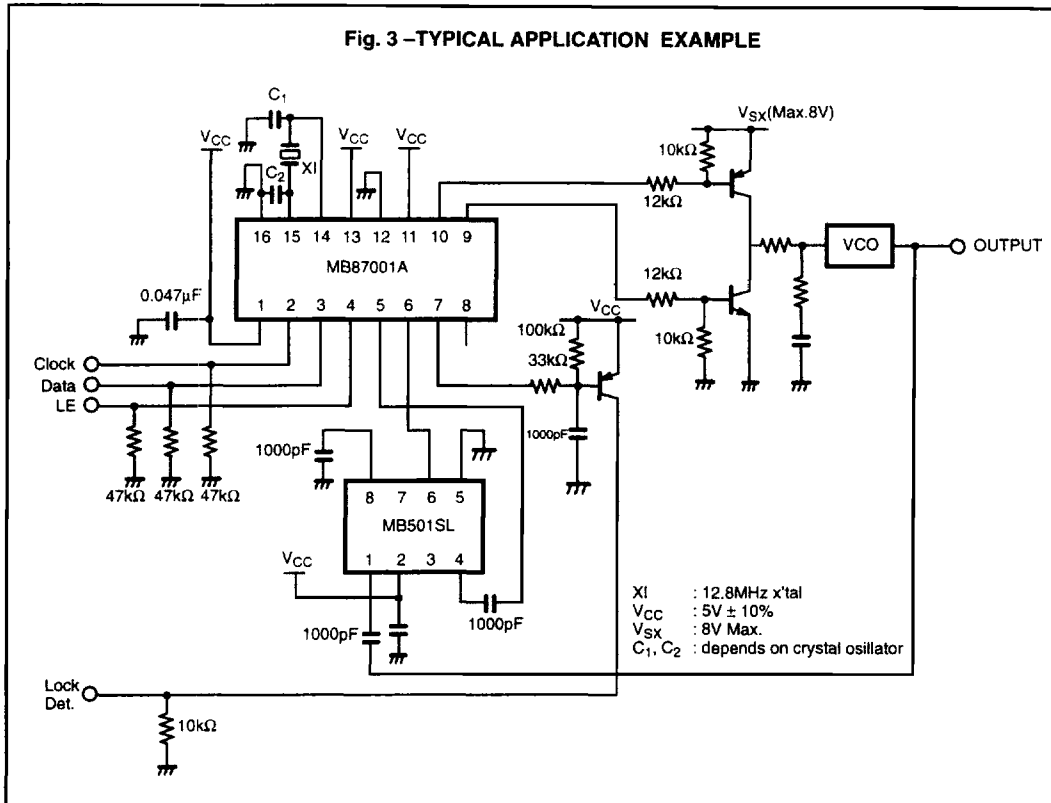

3

TYPICAL CHARACTERISTICS CURVES

Input Sensitivity vs. Input Frequency
(fin Section)

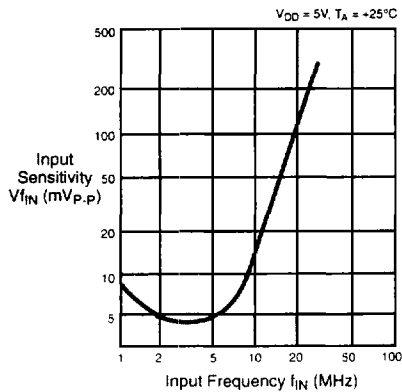

Power Supply Current vs. Input Frequency

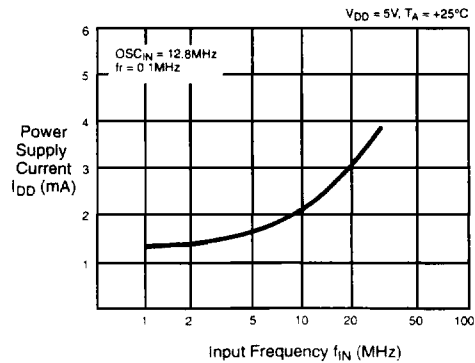

MB87001A

PACKAGE DIMENSIONS

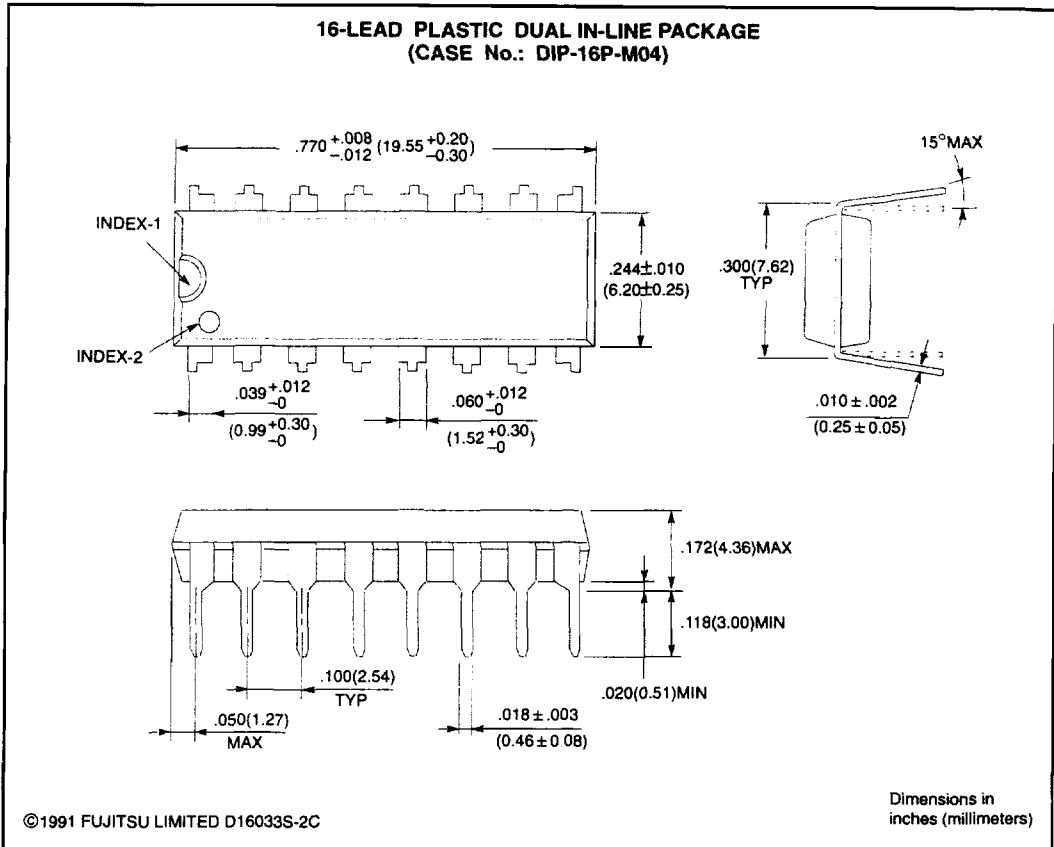

PACKAGE DIMENSIONS (Continued)

