

Absolute Maximum Ratings (T _a = 25 °C)			
Symbol	Term	Values	Units
V _{DD15V}	15 V supply voltage (reference for output signals)	18	V
V _{DD5V}	5 V supply voltage (reference for input signals)	6	V
V _{IH}	input signal voltage (HIGH) max.	V _{DD5V} + 0,3	V
V _{IL}	input signal voltage (Low) min.	GND - 0,3	V
V _{SU}	supply undervoltage monitoring using V _{DD15V}	13,5	V
f _{sw}	switching frequency	50	kHz
T _{op} / T _{stg}	operating/storage temp.	- 25 ... + 85	°C

SEMIDRIVER® IGBT Driver Circuit SKIC 2001

Preliminary Data



Package SOP 28

Features

- IGBT-halfbridge driver circuit with protection functions
- Interlock of TOP and BOTTOM switches of one halfbridge
 - Short pulse suppression
 - Temperature monitoring
 - Supply undervoltage protection
 - V_{CE} error protection
 - Over-current error input
 - Generation of the system clock
 - Integrated DC/DC-converter driver circuit
 - Error monitoring

Typical Applications

- Driving of IGBTs
 - for halfbridge configuration, also for SIXPACK and single switch possible
 - due to isolation (magnetic transformer, optocoupler) can be used for voltages > 1200 V and high power applications

Evaluation boards available on request

1) Values for V_{DD15V}; V_{DD5V}; f_{sw} = 25kHz
 2) input "SELECT" = LOW = t_{TD} = 0 μs
 3) with f_{sw} = 8 MHz at OSC1, OSC2
 4) stand by
 5) capacitive load (max) ≤ 1 nF at V_{DD15V} = 15 V

Electrical Characteristics (T _a = 25 °C) ¹⁾			
Symbol	Term	Values	Units
V _{DD15V}	15 V supply voltage	15 ± 5 %	V
V _{DD5V}	5 V supply voltage	5 ± 5 %	V
V _{BAND-GAP}	reference voltage 10 V	9,99 ... 10,01	V
I _{S5V}	supply current (V _{DD5V}); typ ⁴⁾	3	mA
I _{S15V}	supply current (V _{DD15V}); typ ⁴⁾	15	mA
t _d	propagation time	860	ns
t _{TDswitch} ²⁾	dead time of interlock; typ.	0, 1, 2, 3, 4	μs
t _{supswitch}	short pulse suppression TOP-BOT;typ		
	pulses are suppressed	< 480 ³⁾	ns
	pulses are not suppressed	> 640	ns
t _{supreset}	short pulse suppression RE-SET;typ.	9	μs
input signal TOP, BOTTOM, SELECT, TDT1, TDT2			
V _{it+}	input threshold voltage (High)	3,7 ± 0,2	V
V _{IT-}	input threshold voltage (Low)	1,9 ± 0,2	V
R _{down}	internal pull down resistor (TOP; BOTTOM)	66 ± 2	kΩ
R _{UP}	internal pull up resistor (SELECT, TDT1, TDT2)	64 ± 2	kΩ
ERROR input signals TOPERR, BOTERR			
V _{ET+}	input threshold voltage (High)	> 3,55	V
V _{ET-}	input threshold voltage (LOW)	< 1,3	V
R _{EUUp}	internal pull up resistor	27 ± 0,2	kΩ
f _{swOSZ}	oszillator frequency DC/DC-converter	500 ³⁾	kHz
t _{Td}	time of interlock DC/DC-converter	250	ns
ERROR input signal SENSEERR			
V _{ET+}	input threshold voltage (High)	3,4 ± 0,2	V
V _{ET-}	input threshold voltage (LOW)	2,2 ± 0,2	V
R _{EUUp}	internal pull up resistor	36 ± 2	kΩ
output signal ERROR; TPW, TW			
I _{outmax}	max. output current at V _{DD5V}	± 5	mA
V _{outmax}	max. output voltage at + 5 mA	4,8	V
V _{outmin}	min. output voltage at - 5 mA	0,22	V
output signal TOPOUT; BOTOUT; TR1P; TR1N; TR2P; TR2N			
r _{Ti}	inhibit time for V _{CE} ; ERR	2	μs
t _r typ.	rise time	25 ⁵⁾	ns
t _f typ.	fall time	35 ⁵⁾	ns

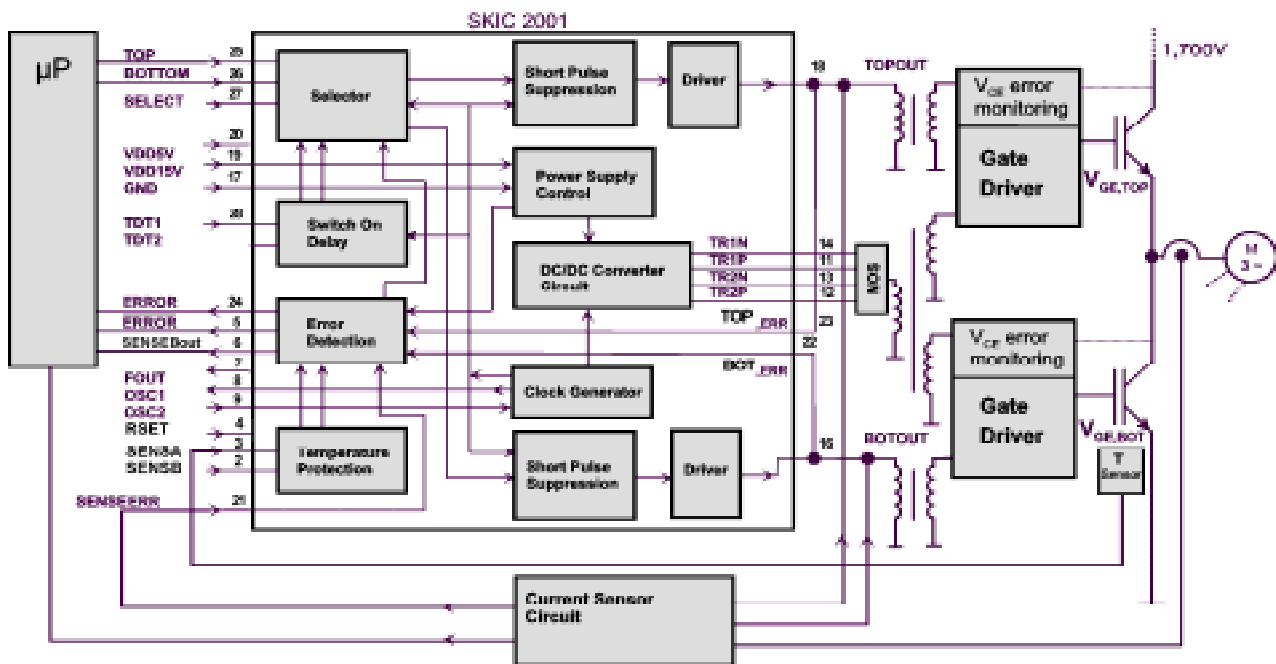

Fig. 1 Functional block diagram of the Control IC (SKIC2001) inside a propulsion control

Pin Array:

PIN-No.	terminal	function
1	TDT2	code for interlock time
2	SENSB	input analogue sense B
3	SENSA	input analogue sense A (type KTY85, optional)
4	RSET	input, analogue temp. sense resistance for adjustment of comparator threshold
5	ERROR	output error signal
6	SENSB_OUT	output for overtemperature signal
7	FOUT	system clock output
8	OSC1	input oscillator
9	OSC2	input oscillator, external switching
10	CPOR	time constante for POWER ON RESET
11	TR1P	output DC/DC-converter
12	TR2P	output DC/DC-converter
13	TR2N	output DC/DC-converter
14	TR1N	output DC/DC-converter
15	VDD15V	supply voltage 15 V
16	BOTOUT	driver output BOTTOM
17	GND	GND
18	TOPOUT	driver output TOP
19	VDD15V	supply voltage 15 V
20	VDD5V	supply voltage 5 V
21	SENSEERR	input error signal, secondary side
22	BOTERR	input error signal, secondary side
23	TOPERR	input error signal, secondary side
24	ERROR	output error signal
25	TOP	driver input TOP
26	BOTTOM	driver input BOTTOM
27	SELECT	interlock on/off
28	TDT1	code or interlock time

Overview

The integrated intelligent controller circuit (SKIC2001) presented for the control of IGBTs, especially in a halfbridge, for high power applications (up to 1,700V and several hundred amperes) and frequencies up to 50kHz. It includes several driver, protection and monitor functions. Fig. 1. shows the functional block diagram of the control IC inside a propulsion control. It consists of a digital control unit, mostly a microprocessor (μ P), the control IC (SKIC 2001), a potential separation (ferrite signal transformer or opto-couplers), the gate driver stages, an IGBT halfbridge and a consumer, in this case a motor.

With the help of the digital unit a pulse frequency modulation of the IGBT driver signals is possible and, therefore, a power control of the consumer can be realized. The developed control circuit contains the signal processing, power supply, the driving and monitoring functions for two IGBTs in a halfbridge (application also for SIXPACK and single switch possible). A power supply of 5V and 15V is necessary. The most important parts, functions, connections and in- and outputs are shown in Fig. 1:

- the forward branch with selector, switch on delay, short pulse suppression, driver and signal transformer to the secondary side (high voltage side)
- the backward branch with error detection and processing (undervoltage, temperature, V_{CE} and overcurrent)
- the additional part with clock generator, power supply control and dc/dc converter circuit

The control circuit has several inputs, some of them with a Schmitt-trigger characteristic for increased noise immunity. TOP and BOTTOM are the main control inputs. RESET sets back the error storage. With TDT1, TDT2 and SELECT a switch on delay between 0 and 4 μ s can be chosen. SENSEA - SENSEB (temperature sensor) and RSET are optional inputs, if the customer applies a temperature monitoring. As temperature sensor a KTY85 is used which is insulated placed on the DCB-substrate. So the temperature of the heat sink is determined. With input RSET the variation of the comparator thresholds (A and B) or adaptations to an other sensor are possible with the help of an external resistance. The error signal of comparator A sets the internal error storage. The error signal of comparator B lies at output SENSEB_OUT.

With the use of ferrite signal transformers the information between primary and secondary side may flow in both directions and high levels of dv/dt and insulation are guaranteed (opto-couplers are also possible). The high frequency dc/dc converter avoids the requirement of an externally insulated power supply to obtain the necessary voltage and power for the IGBT gates. For this operation the dc/dc converter circuit supplies a 15V

signal with a frequency of 500kHz. There is the possibility to use one halfbridge of external power MOSFET (1 pMOS and 1 nMOS) for a lower power supply or a bridge (2 pMOS and 2 nMOS) for a higher power supply.

The IGBT driver stages are externally placed. So the stages can be matched to the respective power range and the optimum function (switching frequency and gate charge of the IGBTs, negative switch off voltage, soft turn off). A short circuit at the IGBT driver stages can be monitored by a permanent control of the collector-emitter-voltage (optionally). In general this method is used, but it has the disadvantage, that a time of a few μ s has to be waited, until we can decide between a normal switch on or a short circuit by the V_{CE} -value. A better and faster method is the evaluation of a differential quotient of the V_{CE} -drop. In the case of a detected short circuit, the IGBT is switched off immediately and an error signal V_{CE} -error is transformed to the control IC.

Another (optional) way to detect a short circuit is the use of a current sensor at the output of the halfbridge (Fig. 1). For high power application a current measuring signal is fundamentally indispensable for an optimum microprocessor control of the propulsion system. We use a newly developed compensating current sensor on the basis of a magnetic field sensor. It can be placed outside or inside the power module. The sensor current (in a ratio of 2000 : 1 to the output current) is converted into a proportional analog voltage signal in the separate sensor circuit and evaluated by the microprocessor. In addition the sensor circuit contains a comparator stage where the same signal is also used for the overcurrent monitoring of the IGBTs. In case of an overcurrent the IGBTs are switched off directly in about 1 μ s and then an error signal I_{ERR} is sent to the control IC. The advantage of this solution is the saving of the expensive V_{CE} -monitoring and the very short reaction time to a short circuit.

An internal protection function of the SKIC 2001 is the power supply control. The circuit will be blocked, if the 15V-power supply drops under a value of about 13,5V. In this case a safe function, especially of the transformers, can't be guaranteed any longer.

All detected error signals are processed in the control IC. The forward driver signal is blocked or the IGBTs are switched off and error signals are given at the output to the microprocessor (ERROR and ERROR for undervoltage of power supply, V_{CE} -error and over temperature). The error storage can be reset by a RESET pulse, which is generated, if 9 μ s the inputs (TOP, BOTTOM) are LOW.