

AEH Half-brick Series

Technical Reference Notes

48V Input, 2.5V Output

50-150W DC-DC Converter

(Rev01)



Introduction

The AEH series comes in a industry standard half-brick package of **2.4" x 2.28" x 0.5"** and footprint, and incorporates the super high efficiency up to 87% in 2.5V output and high power density up to 54.8W/in³. The AEH series is available with 2:1 input range of 36V-75V (and 36V-72V is for 5V output). Outputs of 2.5V, 3.3V, and 5V are fully isolated from input and the isolation voltage is 1500Vdc. **The typical efficiencies are 90% for the 5V output, 89% for the 3V output, and 87% for the 2.5V output.**

Designed using a synchronous rectification topology, AEH series incorporates simple structure, good electrical performance and high reliability. Standard features include input LVP, OCP, output OVP, short circuit protection, and over-temperature protection. Using aluminum based plate, the maximum case temperature can reach 100 °C without derating.

The AEH series is designed to meet CISPR22, FCC Class A, UL, TUV, and CSA certifications.

Design Features

- ☞ High Efficiency
- ☞ High power density
- ☞ Low output noise
- ☞ Metal baseplate
- ☞ CNT function
- ☞ Remote sense
- ☞ Trim function
- ☞ Input under-voltage lockout
- ☞ Output short circuit protection
- ☞ Output current limiting
- ☞ Output over-voltage protection
- ☞ Overtemperature protection
- ☞ High input-output isolation voltage

Options

- ☞ Heat sink available for extended operation.
- ☞ Choice of CNT logic configuration.

Typical Application

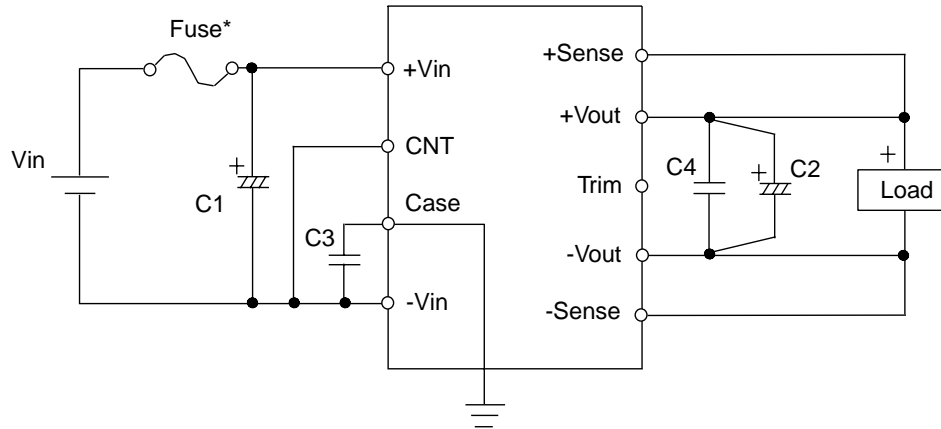

Fuse*: Use external fuse (fast blow type) for each unit.

50W rated output : 5A fuse

75W rated output : 7.5A fuse

100W rated output : 10A fuse

150W rated output : 20A fuse

C1: Recommended input capacitor C1

-40 °C~ +100 °C: $\geq 47\mu\text{F}/100\text{V}$ electrolytic capacitor.

C2: Recommended output capacitor C2

0°C~ +100°C: one 2200 $\mu\text{F}/6.3\text{V}$ electrolytic capacitor

Below 0°C: use 1 X 220 μF tantalum capacitor parallel with a 2200 $\mu\text{F}/6.3\text{V}$ electrolytic capacitor

C3: Recommended 4700pF/2000V

C4: Recommended 1 $\mu\text{F}/10\text{V}$

AEH Half-Brick Power Converters
36VDC to 75VDC Input, 2.5V Output, 50-150W

Block Diagram

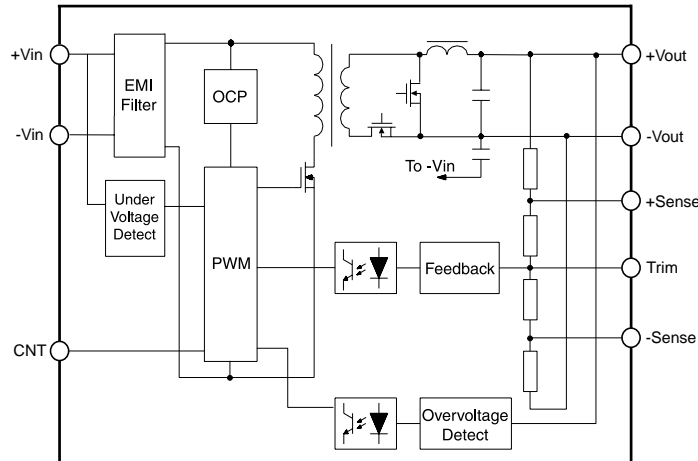

Ordering Information

Model Number	Input Voltage	CNT Logic	Output Current	Ripple (mV rms)	Noise (mV pp)	Efficiency	
						min	typ
AEH10G48N	36-75V	Negative	10A	40	150	84%	86%
AEH10G48	36-75V	Positive	10A	40	150	84%	86%
AEH15G48N	36-75V	Negative	15A	40	150	83%	85%
AEH15G48	36-75V	Positive	15A	40	150	83%	85%
AEH20G48N	36-75V	Negative	20A	40	150	85%	87%
AEH20G48	36-75V	Positive	20A	40	150	85%	87%
AEH30G48N	36-75V	Negative	30A	40	150	83%	85%
AEH30G48	36-75V	Positive	30A	40	150	83%	85%

AEH Half-Brick Power Converters
36VDC to 75VDC Input, 2.5V Output, 50-150W

Absolute Maximum Rating

Characteristic	Min	Typ	Max	Units	Notes
Input Voltage(continuous)	-0.3		80	Vdc	
Input Voltage(peak/surge)	-0.3		100	Vdc	100ms non-repetitive
Operating temperature	-40		100*	°C	*: case temperture
Storage temperature	-55		125	°C	

Input Characteristics

Characteristic	Min	Typ	Max	Units	Notes
Input Voltage Range	36	48	75	Vdc	
Input Reflected Current		25	50	mAp-p	
Turn-off Input Voltage	30	33	35	V	
Turn-on Input Voltage	31	34	36	V	
Turn On Time		15	25	ms	

CNT Function

Characteristic	Min	Typ	Max	Units	Notes
Logic High	3		15	Vdc	
Logic Low			1.2	Vdc	
Control Current			2	mA	

General Specifications

Characteristic	Min	Typ	Max	Units	Notes
MTBF		2080		k Hrs	Bellcore TR332, Tc=30°C
Isolation			1500	Vdc	
Pin solder temperature			260	°C	wave solder < 10 s
Hand Soldering Time			5	s	iron temperature 425°C
Weight		70		grams	

AEH Half-Brick Power Converters
36VDC to 75VDC Input, 2.5V Output, 50-150W

AEH10G48(N) Output Characteristics

Characteristic	Min	Typ	Max	Units	Notes
Power		25		W	
Output Current		10		A	
Output Setpoint Voltage	2.475	2.5	2.525	Vdc	Vin=48V, Io=10A
Line Regulation		0.02	0.2	%Vo	Vin=36~75V, Io=10A
Load Regulation		0.1	0.5	%Vo	Io=0~10A, Vin=48V
Dynamic Response					
50-75% load		1.5		%Vo	Ta=25°C, di/dt = 1A/10µs
		100		µs	Ta=25°C, di/dt = 1A/10µs
50-25% load		1.5		%Vo	Ta=25°C, di/dt = 1A/10µs
		100		µs	Ta=25°C, di/dt = 1A/10µs
Current Limit Threshold	11	12.5	14	A	
Short Circuit Current		17		A	
Efficiency	84	86		%	Vin=48V, Io=10A
Trim Range	90		110	%Vo	
Over Voltage Protection Setpoint	3		3.9	V	
Sense Compensation			10	%Vo	5%Vo each leg
Temperature Regulation			0.02	%Vo/°C	
Ripple (rms)		20	40	mV	(0 to 20MHz Bandwidth)
Noise (p-p)		100	150	mV	(0 to 20MHz Bandwidth)
Over Temperature Protection		105		°C	
Switching Frequency		180		kHz	

AEH Half-Brick Power Converters
36VDC to 75VDC Input, 2.5V Output, 50-150W

AEH15G48(N) Output Characteristics

Characteristic	Min	Typ	Max	Units	Notes
Power		37.5		W	
Output Current		15		A	
Output Setpoint Voltage	2.475	2.5	2.525	Vdc	Vin=48V, Io=15A
Line Regulation		0.02	0.2	%Vo	Vin=36~75V, Io=15A
Load Regulation		0.1	0.5	%Vo	Io=0~15A, Vin=48V
Dynamic Response					
50-75% load		1.5		%Vo	Ta=25°C, di/dt = 1A/10µs
		100		µs	Ta=25°C, di/dt = 1A/10µs
50-25% load		1.5		%Vo	Ta=25°C, di/dt = 1A/10µs
		100		µs	Ta=25°C, di/dt = 1A/10µs
Current Limit Threshold	16.5	19	21	A	
Short Circuit Current		20		A	
Efficiency	83	85		%	Vin=48V, Io=15A
Trim Range	90		110	%Vo	
Over Voltage Protection Setpoint	3		3.9	V	
Sense Compensation			10	%Vo	5%Vo each leg
Temperature Regulation			0.02	%Vo/°C	
Ripple (rms)		20	40	mV	(0 to 20MHz Bandwidth)
Noise (p-p)		100	150	mV	(0 to 20MHz Bandwidth)
Over Temperature Protection		105		°C	
Switching Frequency		180		kHz	

AEH Half-Brick Power Converters
36VDC to 75VDC Input, 2.5V Output, 50-150W

AEH20G48(N) Output Characteristics

Characteristic	Min	Typ	Max	Units	Notes
Power		50		W	
Output Current		20		A	
Output Setpoint Voltage	2.475	2.5	2.525	Vdc	Vin=48V, Io=20A
Line Regulation		0.02	0.2	%Vo	Vin=36~75V, Io=20A
Load Regulation		0.1	0.5	%Vo	Io=0~20A, Vin=48V
Dynamic Response					
50-75% load		1.5		%Vo	Ta=25°C, di/dt = 1A/10µs
		100		µs	Ta=25°C, di/dt = 1A/10µs
50-25% load		2.5		%Vo	Ta=25°C, di/dt = 1A/10µs
		100		µs	Ta=25°C, di/dt = 1A/10µs
Current Limit Threshold	22	25	28	A	
Short Circuit Current		30		A	
Efficiency	85	87		%	Vin=48V, Io=20A
Trim Range	90		110	%Vo	
Over Voltage Protection Setpoint	3		3.9	V	
Sense Compensation			10	%Vo	5%Vo each leg
Temperature Regulation			0.02	%Vo/°C	
Ripple (rms)		20	40	mV	(0 to 20MHz Bandwidth)
Noise (pp)		100	150	mV	(0 to 20MHz Bandwidth)
Over Temperature Protection		105		°C	
Switching Frequency		180		kHz	

AEH Half-Brick Power Converters
36VDC to 75VDC Input, 2.5V Output, 50-150W

AEH30G48(N) Output Characteristics

Characteristic	Min	Typ	Max	Units	Notes
Power		75		W	
Output Current		30		A	
Output Setpoint Voltage	2.475	2.5	2.525	Vdc	Vin=48V, Io=30A
Line Regulation		0.02	0.2	%Vo	Vin=36~75V, Io=30A
Load Regulation		0.1	0.5	%Vo	Io=0~30A, Vin=48V
Dynamic Response					
50-75% load		2.5		%Vo	Ta=25°C, di/dt = 1A/10µs
		100		µs	Ta=25°C, di/dt = 1A/10µs
50-25% load		2.5		%Vo	Ta=25°C, di/dt = 1A/10µs
		100		µs	Ta=25°C, di/dt = 1A/10µs
Current Limit Threshold	32	36	40	A	
Short Circuit Current		40		A	
Efficiency	83	85		%	Vin=48V, Io=30A
Trim Range	90		110	%Vo	
Over Voltage Protection Setpoint	3		3.9	V	
Sense Compensation			10	%Vo	5%Vo each leg
Temperature Regulation			0.02	%Vo/°C	
Ripple (rms)		20	40	mV	(0 to 20MHz Bandwidth)
Noise (pp)		100	150	mV	(0 to 20MHz Bandwidth)
Over Temperature Protection		105		°C	
Switching Frequency		180		kHz	

Characteristic Curves (at 25 °C)

Typical Efficiency AEH10G48N

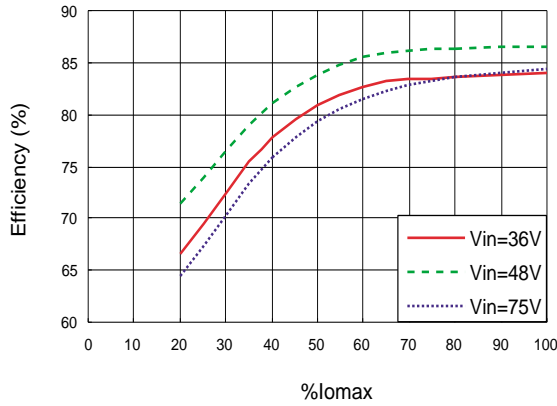

Typical Efficiency AEH15G48N

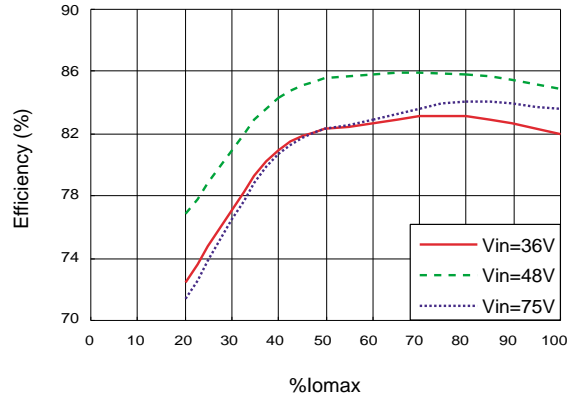

Typical Efficiency AEH20G48N

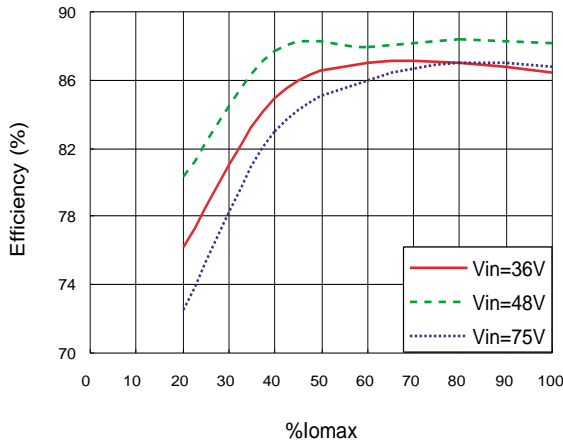

Typical Efficiency AEH30G48N

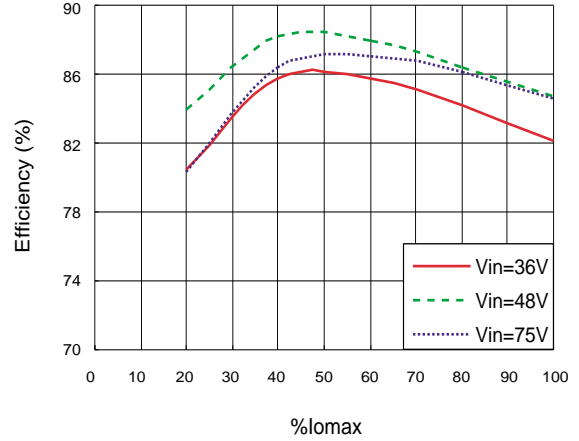

Characteristic Curves (at 25 °C)

**Typical Output Overcurrent Characteristics
AEH10G48N**

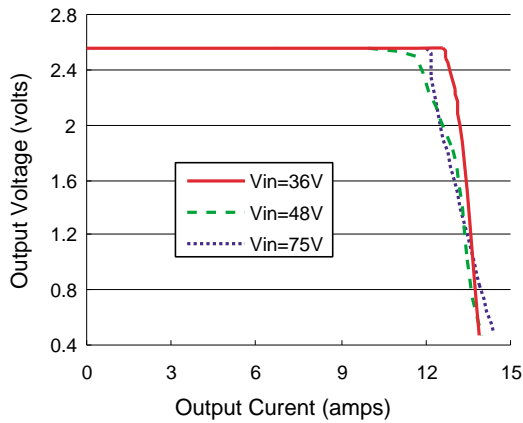

**Typical Output Overcurrent Characteristics
AEH15G48N**

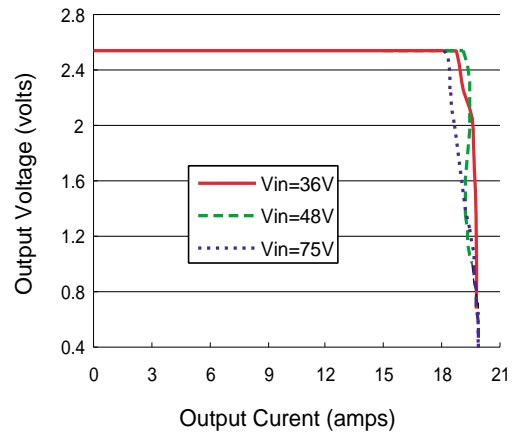

**Typical Output Overcurrent Characteristics
AEH20G48N**

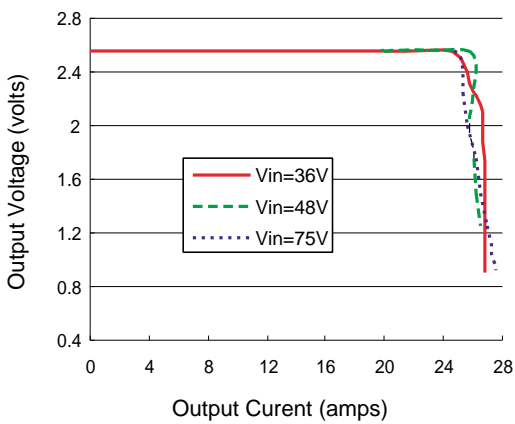

**Typical Output Overcurrent Characteristics
AEH30G48N**

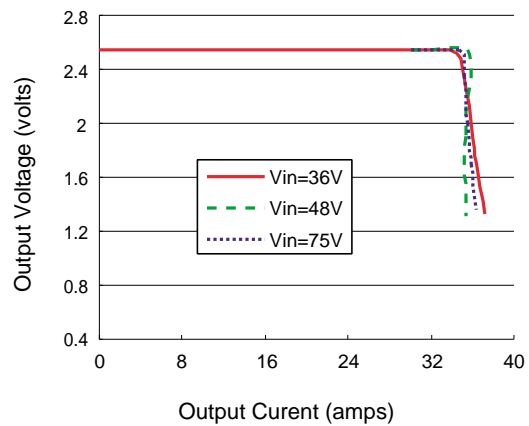

Characteristic Curves (at 25 °C)

**Typical Input-Output Characteristics
 AEH10G48N**

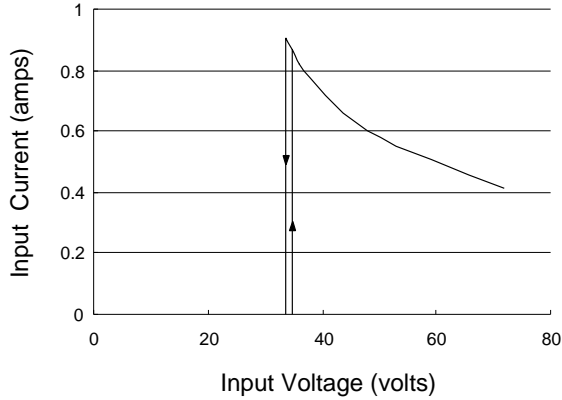

**Typical Input-Output Characteristics
 AEH15G48N**

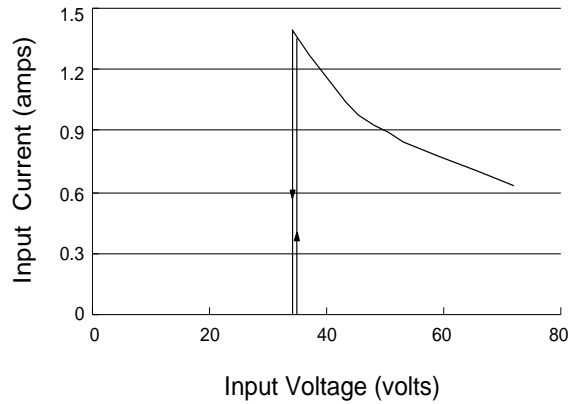

**Typical Input-Output Characteristics
 AEH20G48N**

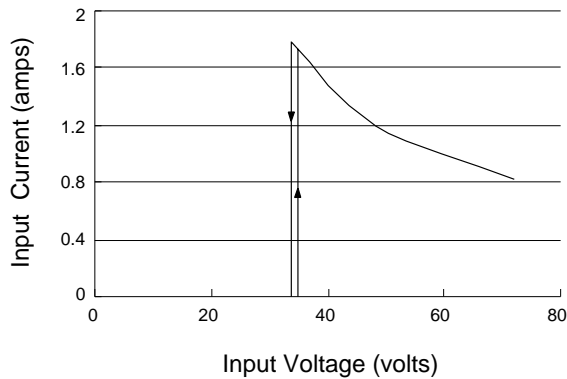

**Typical Input-Output Characteristics
 AEH30G48N**

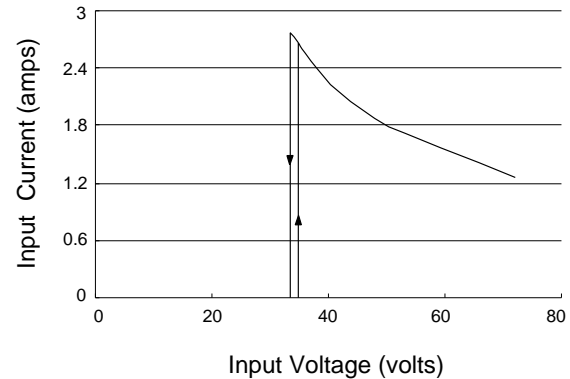

Transient response (48V rated input voltage, full load, at 25 °C)

**Typical Transient Response to Step Load
Change from 25%-50%-25%I_omax
AEH10G48N**

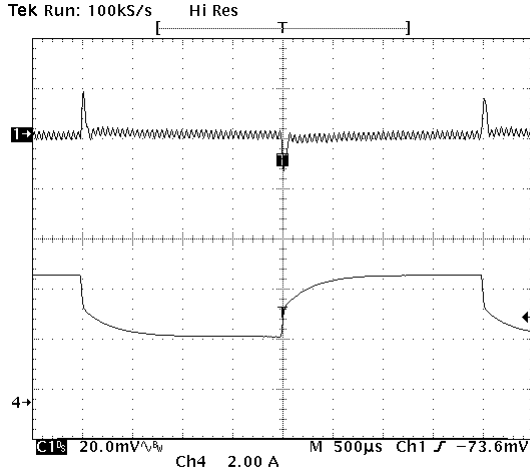

**Typical Transient Response to Step Load
Change from 25%-50%-25%I_omax
AEH15G48N**

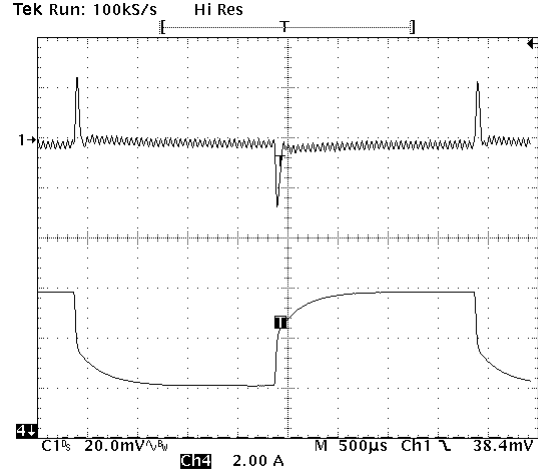

**Typical Transient Response to Step Load
Change from 25%-50%-25%I_omax
AEH20G48N**

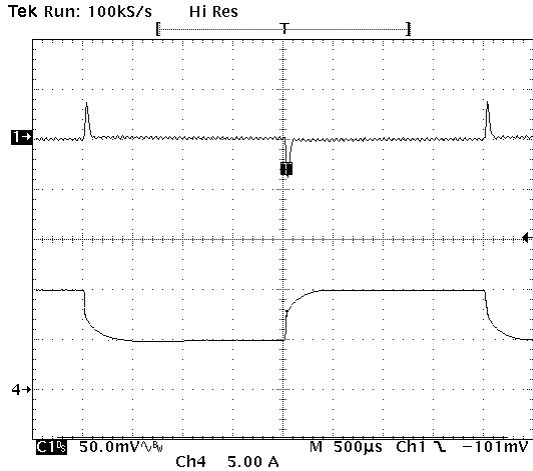

**Typical Transient Response to Step Load
Change from 25%-50%-25%I_omax
AEH30G48N**

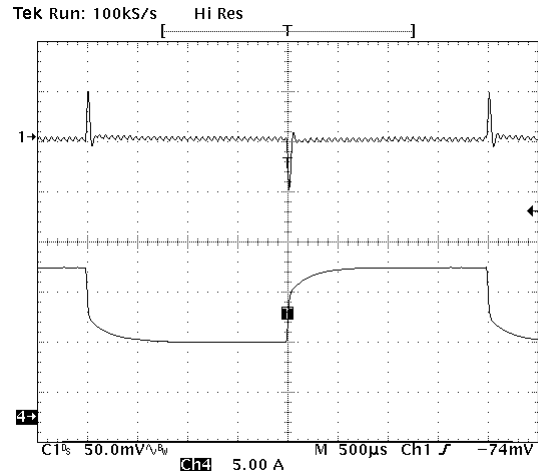

Transient response (48V rated input voltage, full load, at 25 °C)

**Typical Transient Response to Step Load
Change from 50%-75%-50%I_omax
AEH10G48N**

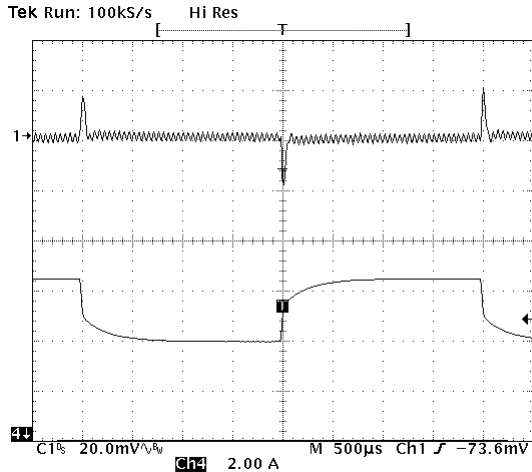

**Typical Transient Response to Step Load
Change from 50%-75%-50%I_omax
AEH15G48N**

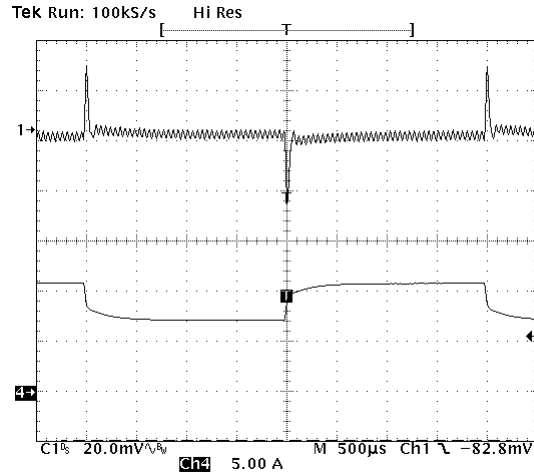

**Typical Transient Response to Step Load
Change from 50%-75%-50%I_omax
AEH20G48N**

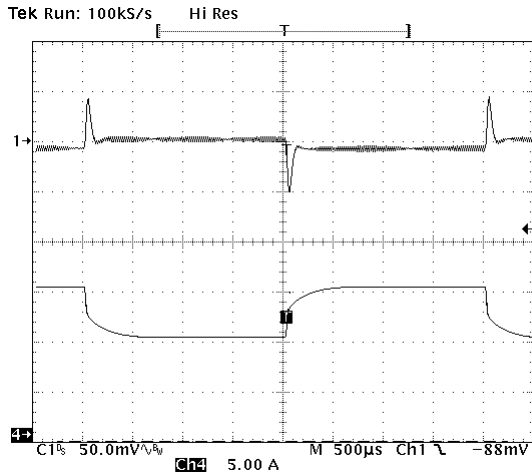

**Typical Transient Response to Step Load
Change from 50%-75%-50%I_omax
AEH30G48N**

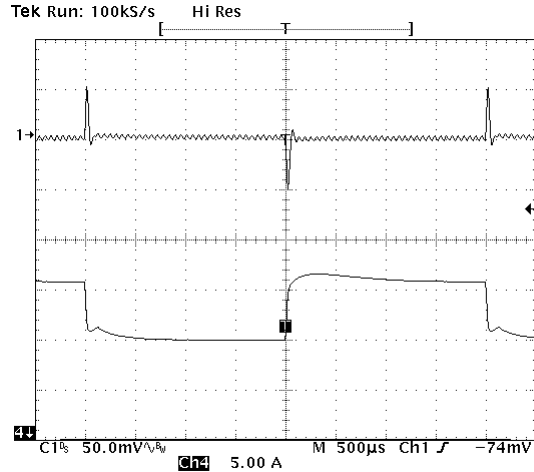

Characteristic Curves *(48V rated input voltage, full load, at 25 °C)*

**Typical Start-Up from Power On
AEH10G48N**

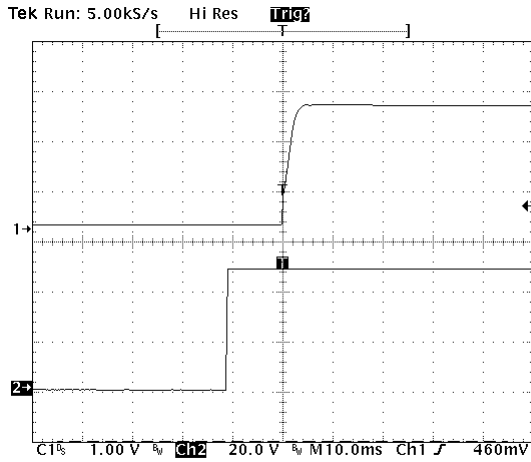

**Typical Start-Up from Power On
AEH15G48N**

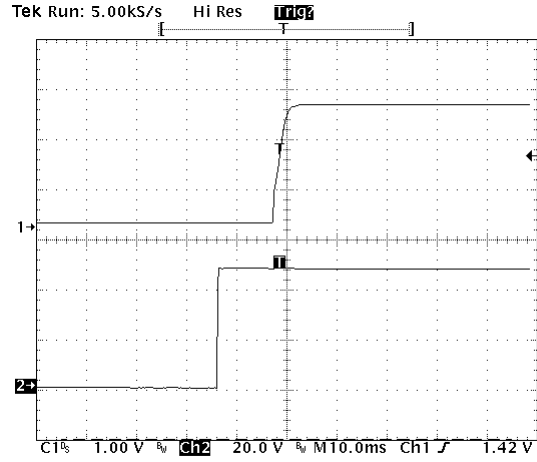

**Typical Start-Up from Power On
AEH20G48N**

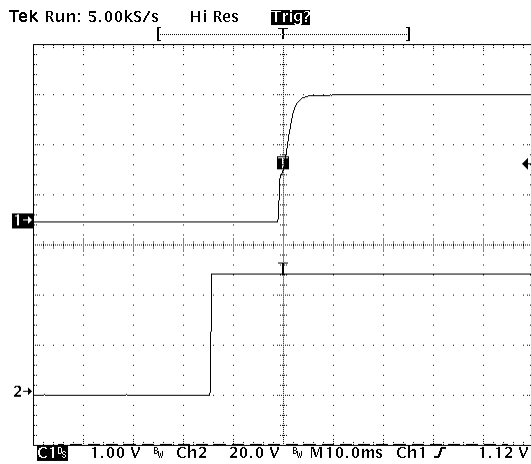

**Typical Start-Up from Power On
AEH30G48N**

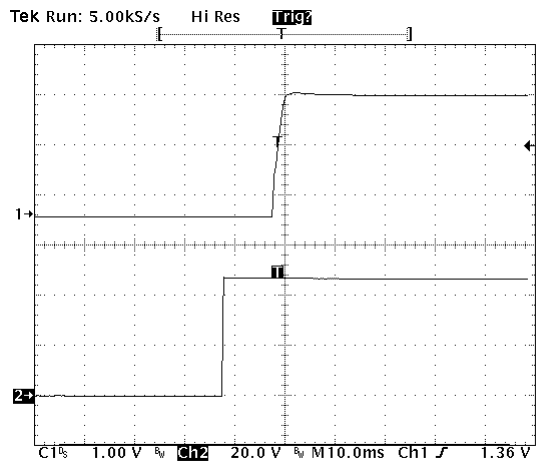

Characteristic Curves *(48V rated input voltage, full load, at 25 °C)*

Typical Shut-down from Power Off
AEH10G48N

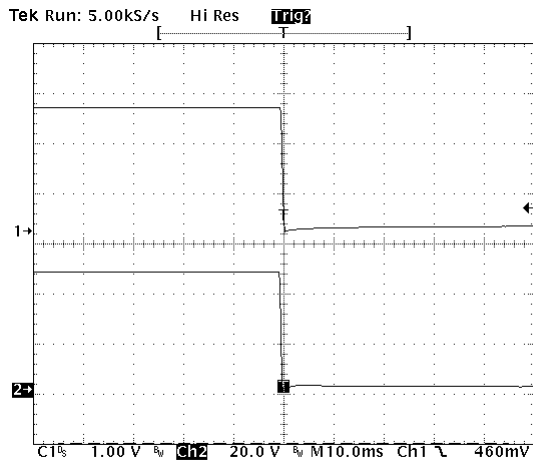

Typical Shut-down from Power Off
AEH15G48N

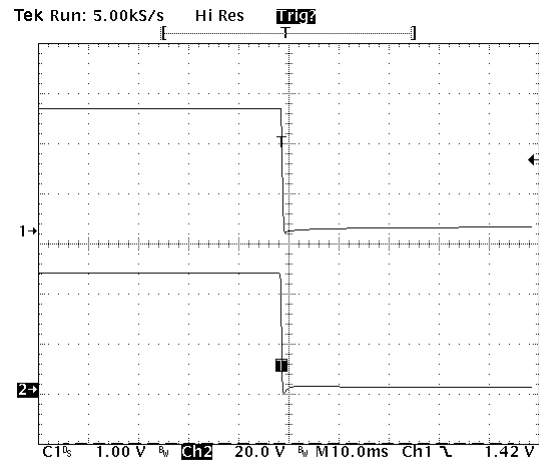

Typical Shut-down from Power Off
AEH20G48N

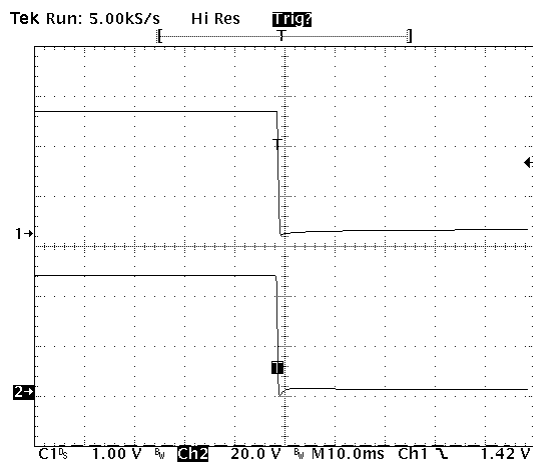

Typical Shut-down from Power Off
AEH30G48N

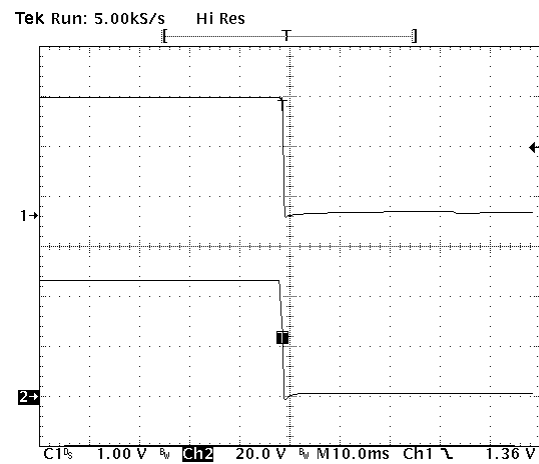

Characteristic Curves *(48V rated input voltage, full load, at 25 °C)*

**Typical Start-Up Transient with CNT Control
AEH10G48N**

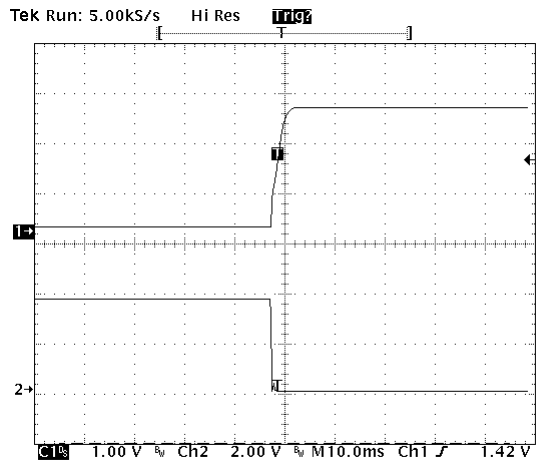

**Typical Start-Up Transient with CNT Control
AEH15G48N**

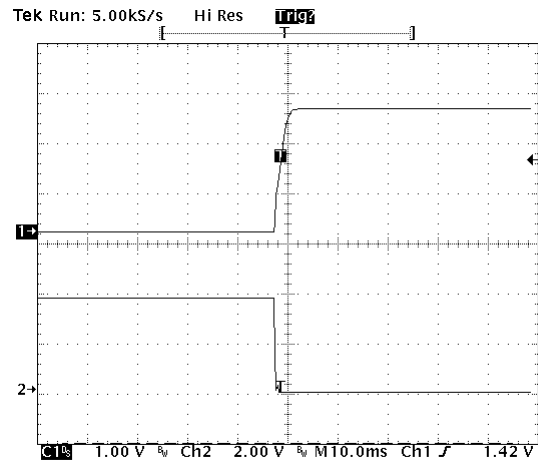

**Typical Start-Up Transient with CNT Control
AEH20G48N**

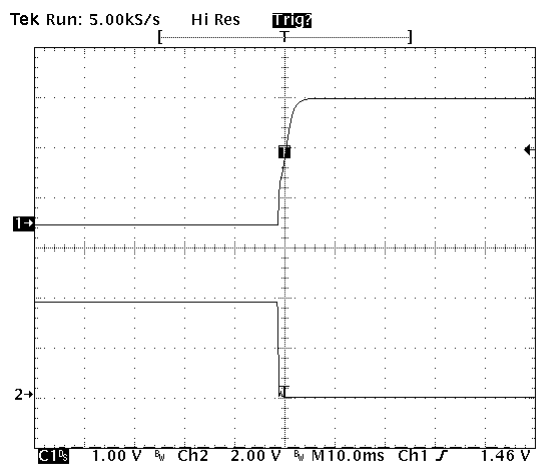

**Typical Start-Up Transient CNT Control
AEH30G48N**

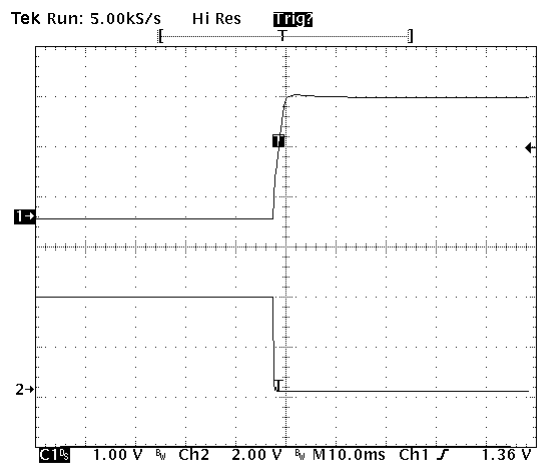

Characteristic Curves *(48V rated input voltage, full load, at 25 °C)*

Typical Shut-down Transient with CNT Control
AEH10G48N

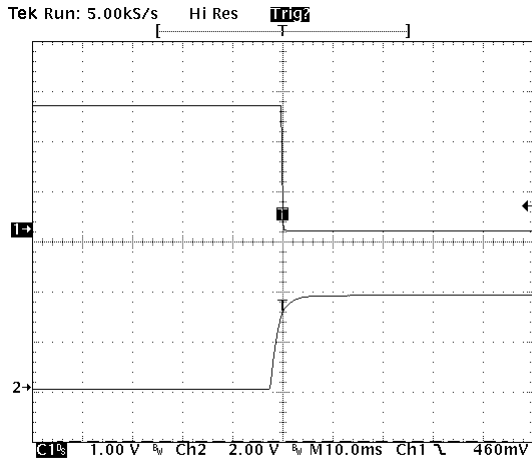

Typical Shut-down Transient with CNT Control
AEH15G48N

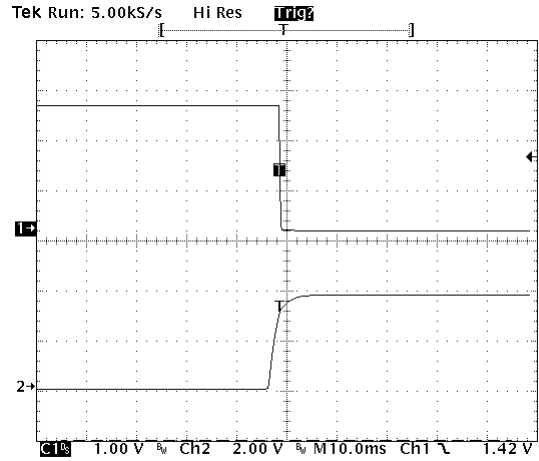

Typical Shut-down Transient with CNT Control
AEH20G48N

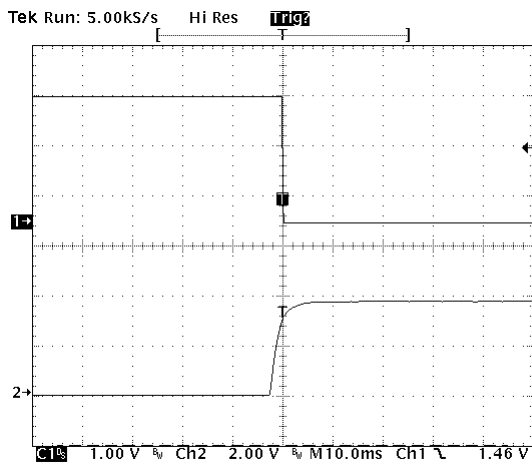

Typical Shut-down Transient with CNT Control
AEH30G48N

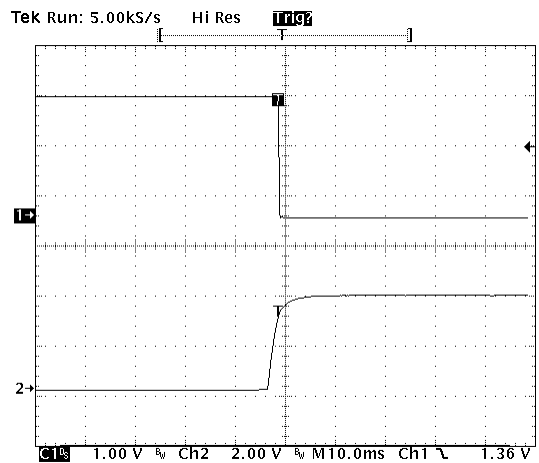

Characteristic Curves (48V rated input voltage, full load, at 25 °C)

Typical Output Ripple Voltage
AEH10G48N

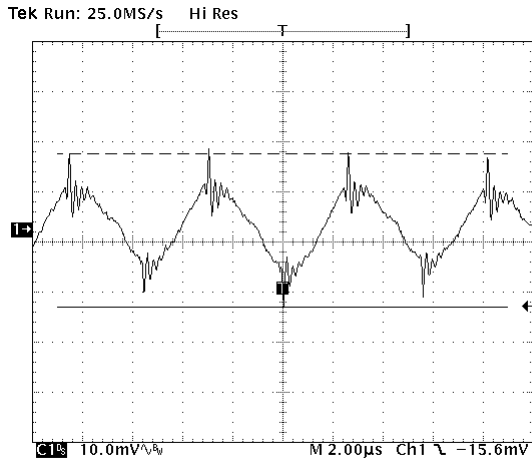

Typical Output Ripple Voltage
AEH15G48N

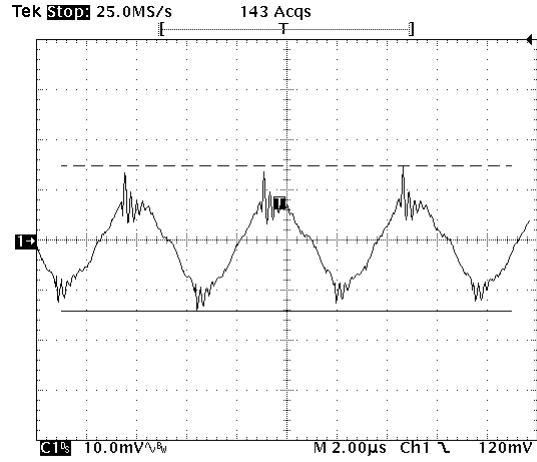

Typical Output Ripple Voltage
AEH20G48N

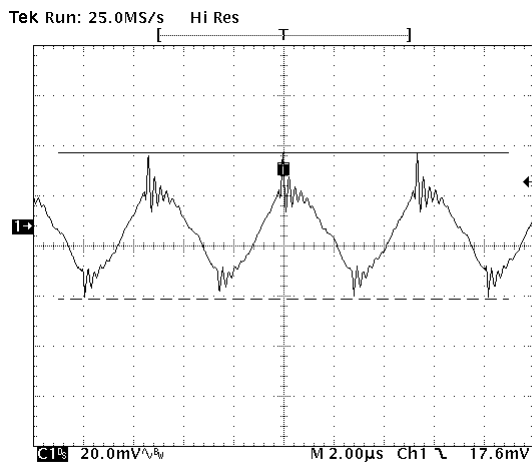

Typical Output Ripple Voltage
AEH30G48N

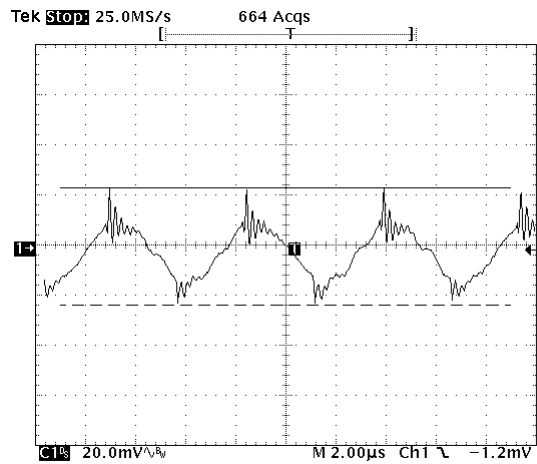

Characteristic Curves *(48V rated input voltage, full load, at 25 °C)*

**Overvoltage Protection
AEH10G48N**

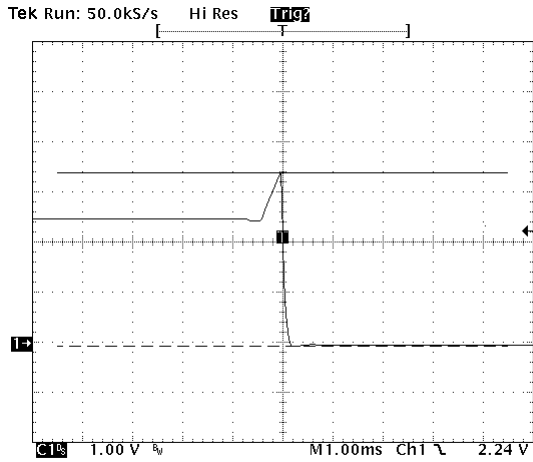

**Overvoltage Protection
AEH15G48N**

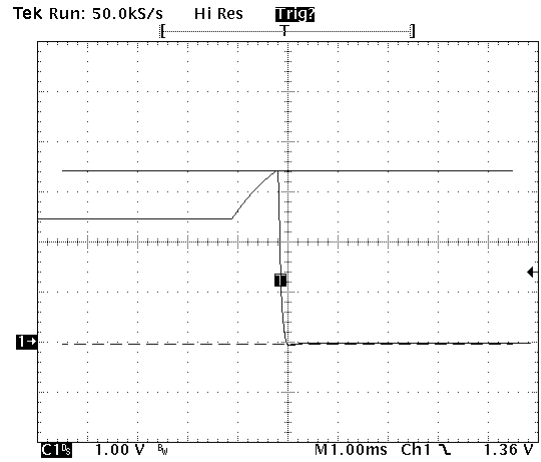

**Overvoltage Protection
AEH20G48N**

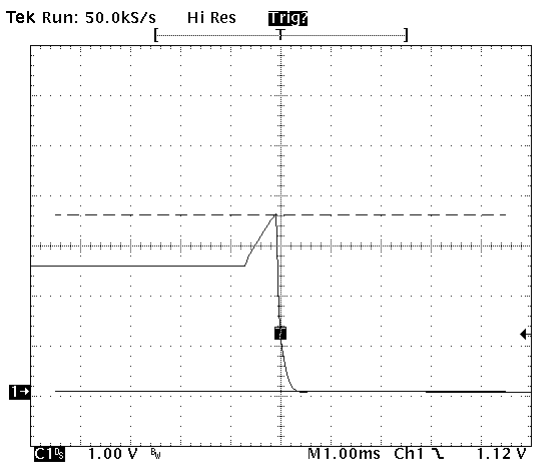

**Overvoltage Protection
AEH30G48N**

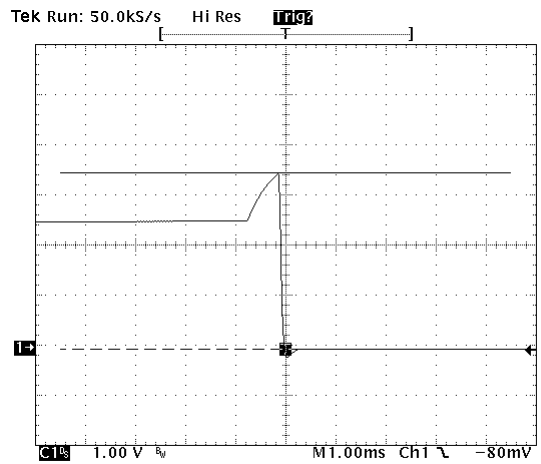

Pins

The +Vin and -Vin input connection pins are located as shown in Figure 1. AEH converters have a 2:1 input voltage range and 2.5V output converters can accept 36-75 Vdc.

Care should be taken to avoid applying reverse polarity to the input which can damage the converter.

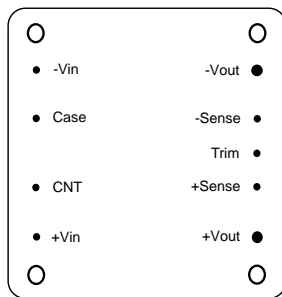

Component-side footprint

Fig.1 Pin Location

Input Characteristic

Fusing

The AEH power module has no internal fuse. An external fuse must always be employed! To meet international safety requirements, a 250 Volt rated fuse should be used. If one of the input lines is connected to chassis ground, then the fuse must be placed in the other input line.

Table 1

Rated P _{out}	Fuse Rating
50 Watt	5A
75 Watt	7.5A
100 Watt	10A
150 Watt	20A

Standard safety agency regulations require input fusing. Recommended fuse ratings for the AEH Series are shown in Table 1.

Input Reverse Voltage Protection

Under installation and cabling conditions where reverse polarity across the input may occur, reverse polarity protection is recommended. Protection can easily be provided as shown in Figure 2. In both cases the diode rating is determined by the power of the converter. Diodes should be rated at 20A/100V for 150W, 10A/100V for 100W, 7.5A/100V for 75W, and 5A/100V for 50W.

Placing the diode across the inputs rather than in-line with the input offers an advantage in that the diode only conducts in a reverse polarity condition, which increases circuit efficiency and thermal performance.

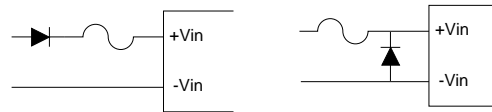

Fig.2 Reverse Polarity Protection Circuits

Input Undervoltage Protection

The AEH is protected against undervoltage on the input. If the input voltage drops below the acceptable range, the converter will shut down. It will automatically restart when the undervoltage condition is removed.

Input Filter

Input filters are included in the converters to help achieve standard system emissions certifications. Some users however, may find that additional input filtering is necessary. The AEH 2.5V output series has an internal switching frequency of 180kHz so a high frequency capacitor mounted close to the input terminals pro-

AEH Half-Brick Power Converters
36VDC to 75VDC Input, 2.5V Output, 50-150W

duces the best results. To reduce reflected noise, a capacitor can be added across the input as shown in Figure 3, forming a π filter. A 47 μ F/100V electrolytic capacitor is recommended for C1.

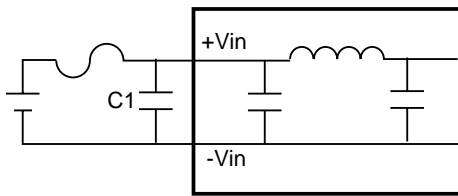

Fig.3 Ripple Rejection Input Filter

For conditions where EMI is a concern, a different input filter can be used. Figure 4 shows an input filter designed to reduce EMI effects. L1 is a 5mH common mode choke.

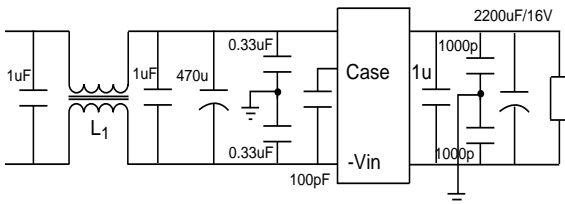

Fig.4 EMI Reduction Input Filter

When a filter inductor is connected in series with the power converter input, an input capacitor C1 should be added. An input capacitor C1 should also be used when the input wiring is long, since the wiring can act as an inductor. Failure to use an input capacitor under these conditions can produce large input voltage spikes and an unstable output.

CNT Function

Two CNT options are available.

Negative logic applying a voltage less than 1.2V to the CNT pin will enable the output, and applying a voltage greater than 3V will disable it.

Positive logic applying a voltage larger than

3V to the CNT pin will enable the output, and applying a voltage less than 1.2V will disable it. Positive logic, device code suffix “ P “. Negative logic, device code suffix nothing is the factory-preferred.

If the CNT pin is left open, the converter will default to “ control off ” operation in negative logic, but default to “ control on ” in positive logic.

The maximum voltage that can be applied to the CNT pin is 15V.

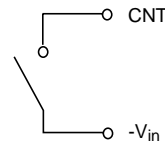

Fig.5 Simple Control

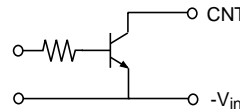

Fig.6 Transistor Control

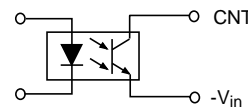

Fig.7 Isolated Control

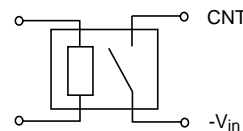

Fig.8 Relay Control

Input-Output Characteristic

Safety Consideration

For safety-agency approval of the system in which the power module is used, the power module must be installed in compliance with the spacing and separation requirements of the end-use safety agency standard, i.e., UL1950, CSA C22.2 No. 950-95, and EN60950. The

input-to-output 1500VDC isolation is an operational insulation. The DC/DC power module should be installed in end-use equipment, in compliance with the requirements of the ultimate application, and is intended to be supplied by an isolated secondary circuit. When the supply to the DC/DC power module meets all the requirements for SELV(<60Vdc), the output is considered to remain within SELV limits (level 3). If connected to a 60Vdc power system, double or reinforced insulation must be provided in the power supply that isolates the input from any hazardous voltages, including the ac mains. One Vin pin and one Vout pin are to be grounded or both the input and output pins are to be kept floating. Single fault testing in the power supply must be performed in combination with the DC/DC power module to demonstrate that the output meets the requirement for SELV. The input pins of the module are not operator accessible.

Note: Do not ground either of the input pins of the module, without grounding one of the output pins. This may allow a non-SELV voltage to appear between the output pin and ground.

Case Grounding

For proper operation of the module, the case or baseplate of the AEH module does not require a connection to a chassis ground. If the AEH module is not in a metallic enclosure in a system, it may be advisable to directly ground the case to reduce electric field emissions. Leaving the case floating can help to reduce magnetic field radiation from common mode noise currents. If the case has to be grounded for safety or other reasons, an inductor can be connected to chassis at DC and AC line frequencies, but be left floating at switching frequencies. Under this condition, the safety requirements are met and the emissions are minimized.

Output Characteristics

Minimum Load Requirement

There is no minimum load required for the AEH series modules.

Remote Sensing

The AEH converter can remotely sense both lines of its output which moves the effective output voltage regulation point from the output of the unit to the point of connection of the remote sense pins. This feature automatically adjusts the real output voltage of the AEH in order to compensate for voltage drops in distribution and maintain a regulated voltage at the point of load.

When the converter is supporting loads far away, or is used with undersized cabling, significant voltage drop can occur at the load. The best defense against such drops is to locate the load close to the converter and to ensure adequately sized cabling is used. When this is not possible, the converter can compensate for a drop of up to 0.5V, through use of the sense leads.

When used, the + and - Sense leads should be connected from the converter to the point of load as shown in Figure 9 using twisted pair wire. The converter will then regulate its output voltage at the point where the leads are connected. Care should be taken not to reverse the sense leads. If reversed, the converter will trigger OVP protection and turn off. When not

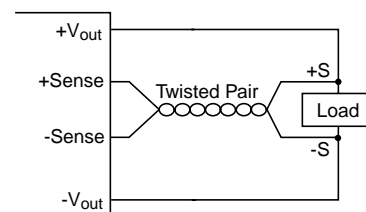

Fig.9 Sense Connections

AEH Half-Brick Power Converters 36VDC to 75VDC Input, 2.5V Output, 50-150W

used, the +Sense lead must be connected with +Vo, and -Sense with -Vo. Also note that the output voltage and the remote sense voltage offset must be less than the minimum overvoltage trip point. **Note that at elevated output voltages the maximum power rating of the module remains the same, and the output current capability will decrease correspondingly.**

Output Trimming

Users can increase or decrease the output voltage set point of a module by connecting an external resistor between the TRIM pin and either the SENSE (+) or SENSE (-) pins. The trim resistor should be positioned close to the module. **If not using the trim feature, leave the TRIM pin open.**

Trimming up by more than 10% of the nominal output may damage the converter or trig the OVP protection. Trimming down more than 10% can cause the converter to regulate improperly. Trim down and trim up circuits and the corresponding configuration are shown in Figure 10 to Figure 13.

Note that at elevated output voltages the maximum power rating of the module remains the same, and the output current capability will decrease correspondingly.

Output Over-Current Protection

AEH series DC/DC converters feature foldback current limiting as part of their Overcurrent Protection (OCP) circuits. When output current exceeds 110 to 140% of rated current, such as during a short circuit condition, the output will shutdown immediately, and can tolerate short circuit conditions indefinitely. When the overcurrent condition is removed, the converter will automatically restart.

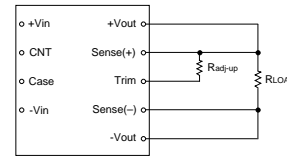

$$R_{\text{adj-up}} = \frac{V_o(100+y)}{1.26y} - \frac{(100+2y)}{y}$$

Where y is the adjusting percentage of the voltage.
0 < y < 10
Radj-up is in kΩ.

Fig.10 Circuit Configuration and Equation to Trim Up Output Voltage

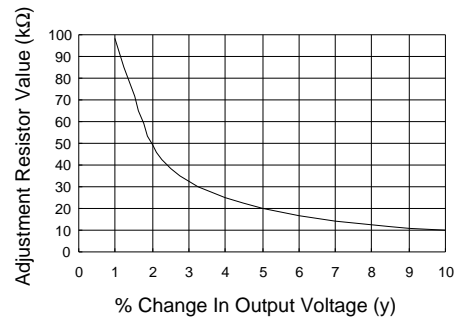
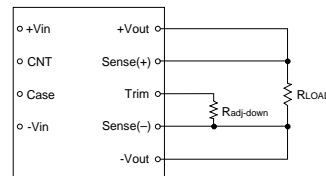

Fig.11 Resistor Selection for Trimming Up 2.5V Outputs



$$R_{\text{adj-down}} = \frac{100}{y} - 2$$

where y is the adjusting percentage of the voltage.
0 < y < 10
Radj-down is in kΩ.

Fig.12 Circuit Configuration and Equation to Trim Down Output Voltage

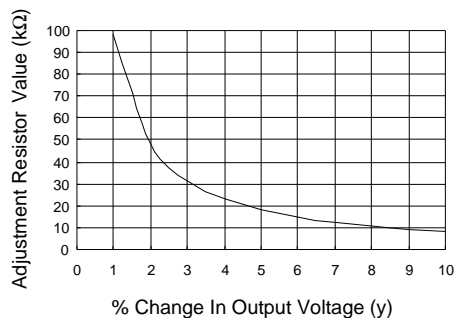

Fig.13 Resistor Selection for Trimming Down Output Voltage

Output Filters

When the load is sensitive to ripple and noise, an output filter can be added to minimize the effects. A simple output filter to reduce output ripple and noise can be made by connecting a capacitor across the output as shown in Figure 14. The recommended value for the output capacitor C1 is 2,200 μ F/10V.

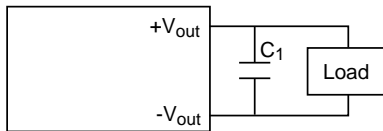

Fig.14 Output Ripple Filter

Extra care should be taken when long leads or traces are used to provide power to the load. Long lead lengths increase the chance for noise to appear on the lines. Under these conditions C2 can be added across the load as shown in Figure 15. The recommended component for C2 is 2200 μ F/10V capacitor and connecting a 0.1 μ F ceramic capacitor C1 in parallel generally.

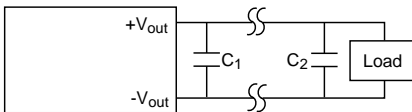

Fig.15 Output Ripple Filter For a Distant Load

Decoupling

Noise on the power distribution system is not always created by the converter. High speed analog or digital loads with dynamic power demands can cause noise to cross the power inductor back onto the input lines. Noise can be reduced by decoupling the load. In most cases, connecting a 10 μ F tantalum capacitor in parallel with a 0.1 μ F ceramic capacitor across the

load will decouple it. The capacitors should be connected as close to the load as possible.

Ground Loops

Ground loops occur when different circuits are given multiple paths to common or earth ground, as shown in Figure 16. Multiple ground points can slightly different potential and cause current flow through the circuit from one point to another. This can result in additional noise in all the circuits. To eliminate the problem, circuits should be designed with a single ground connection as shown in Figure 17.

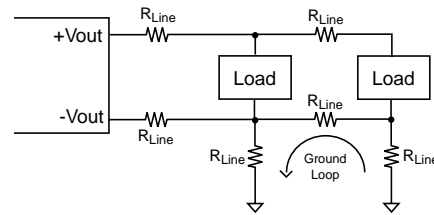

Fig.16 Ground Loops

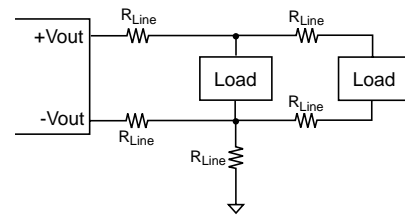

Fig.17 Single Point Ground

Output Over-Voltage Protection

The over-voltage protection has a separate feedback loop which activates when the output voltage is between 120% and 140% of the nominal output voltage. When an over-voltage condition occurs, a “ turn off “ signal was sent to the input of the module, and shut off the output. The module will restart after power on again.

Parallel Power Distribution

Figure 18 shows a typical parallel power distribution design. Such designs, sometimes called daisy chains, can be used for very low output currents, but are not normally recommended. The voltage across loads far from the source can vary greatly depending on the IR drops along the leads and changes in the loads closer to the source. Dynamic load conditions increase the potential problems.

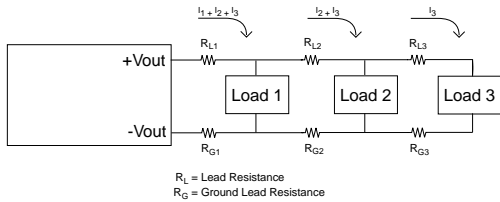

Fig.18. Parallel Power Distribution

Radial Power Distribution

Radial power distribution is the preferred method of providing power to the load. Figure 19 shows how individual loads are connected directly to the power source. This arrangement requires additional power leads, but it avoids the voltage variation problems associated with the parallel power distribution technique.

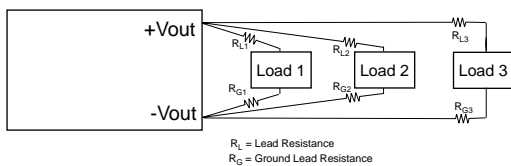

Fig.19 Radial Power Distribution

Mixed Distribution

In the real world a combination of parallel and radial power distribution is often used. Dynamic and high current loads are connected using a radial design, while static and low current loads can be connected in parallel. This combined approach minimizes the drawbacks of a parallel

design when a purely radial design is not feasible.

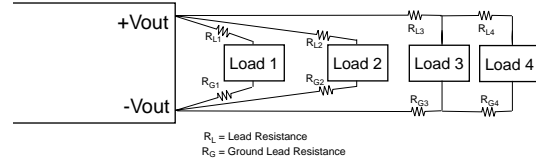

Fig.20 Mixed Power Distribution

Redundant Operation

A common requirement in high reliability systems is to provide redundant power supplies. The easiest way to do this is to place two converters in parallel, providing fault tolerance but not load sharing. Oring diodes should be used to ensure that failure of one converter will not cause failure of the second. Figure 21 shows such an arrangement. Upon application of power, one of the converters will provide a slightly higher output voltage and will support the full load demand. The second converter will see a zero load condition and will "idle". If the first converter should fail, the second converter will support the full load. When designing redundant converter circuits, Schottky diodes should be used to minimize the forward voltage drop. The voltage drop across the Schottky diodes must also be considered when determining load voltage requirements.

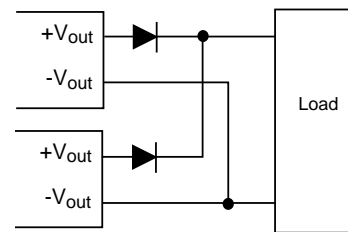

Fig.21 Redundant Operation

Thermal Management

Technologies

AEH Series 50 W to 150 W modules feature high efficiency and the 2.5 V output units have typical efficiency of 86% at full load. With less heat dissipation and temperature-resistant components such as ceramic capacitors, these modules exhibit good behavior during prolonged exposure to high temperatures. Maintaining the operating case temperature (T_c) within the specified range help keep internal-component temperatures within their specifications which in turn help keep MTBF from falling below the specified rating. Proper cooling of the power modules is also necessary for reliable and consistent operation.

Basic Thermal Management

Measuring the case temperature of the module (T_c) as the method shown in Figure 22 can verify the proper cooling. Figure 22 shows the metal surface of the module and the pin locations. The module should work under 90°C for the reliability of operation and T_c must not exceed 100 °C while operating in the final system configuration. The measurement can be made with a surface probe after the module has reached thermal equilibrium. If a heat sink is mounted to the case, make the measurement as close as possible to the indicated position. It makes the assumption that the final system configuration exists and can be used for a test environment.

The following text and graphs show guidelines to predict the thermal performance of the module for typical configurations that include heat sinks in natural or forced airflow environments. Note that T_c of module must always be checked in the final system configuration to verify proper

operational due to the variation in test conditions.

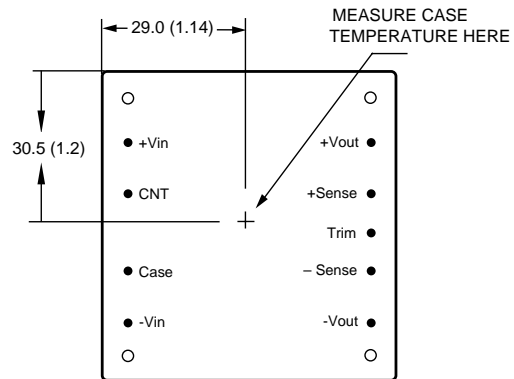

Base-plate side View
 Dimensions: millimeters (inches)

Fig.22 Case Temperature Measurement

Thermal management acts to transfer the heat dissipated by the module to the surrounding environment. The amount of power dissipated by the module as heat (P_D) is got by the equation below:

$$P_D = P_I - P_O$$

where : P_I is input power;

P_O is output power;

P_D is dissipated power.

Also, module efficiency (η) is defined as the following equation:

$$\eta = P_O / P_I$$

If eliminating the input power term, from two above equations can yield the equation below:

$$P_D = P_O (1 - \eta) / \eta$$

The module power dissipation then can be calculated through the equation.

Because each power module output voltage has a different power dissipation curve, a plot of power dissipation versus output current over three different line voltages is given in each module-specific data sheet. The typical power dissipation curve of AEH series 2.5V output are shown as figure 23 to figure 26.

AEH Half-Brick Power Converters
36VDC to 75VDC Input, 2.5V Output, 50-150W

Module Derating

Experiment Setup

From the experimental set up shown in figure 27, the derating curves as figure 28 can be drawn. Note that the PWB (printed-wiring board) and the module must be mounted vertically. The passage has a rectangular cross-section. The clearance between the facing PWB and the top of the module is kept 13 mm (0.5 in.) constantly.

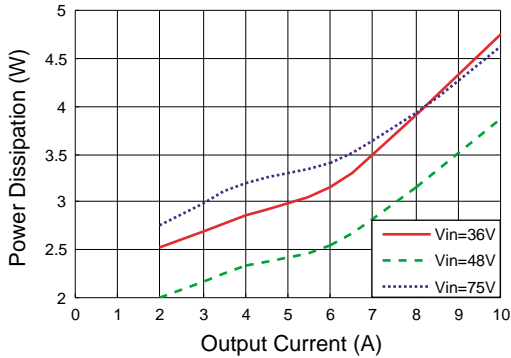

Fig.23 AEH10G48 Power Dissipation Curves

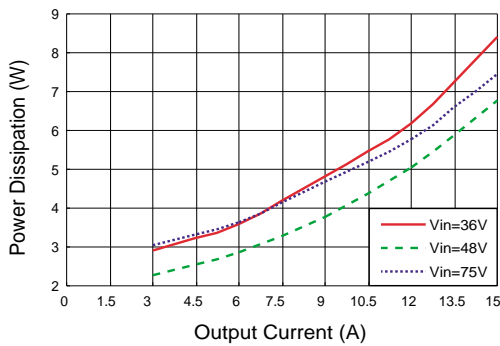

Fig.24 AEH15G48 Power Dissipation Curves

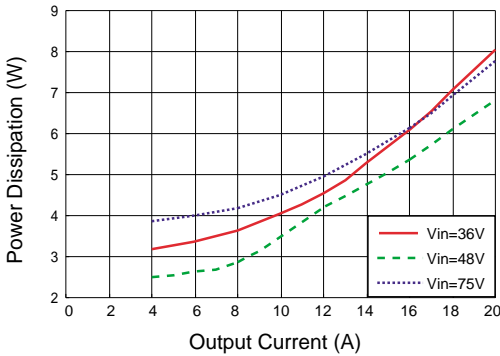

Fig.25 AEH20G48 Power Dissipation Curves

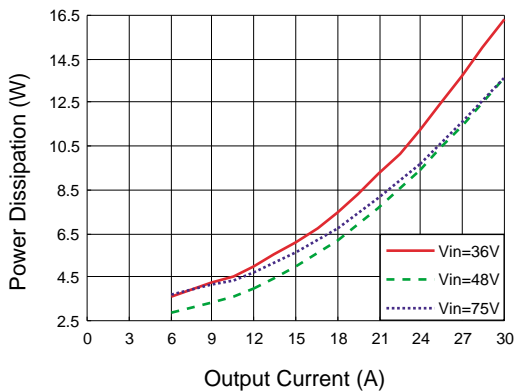

Fig.26 AEH30G48 Power Dissipation Curves

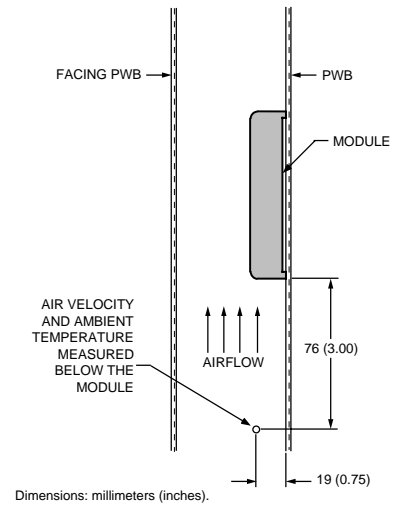

Fig.27 Experiment Set Up

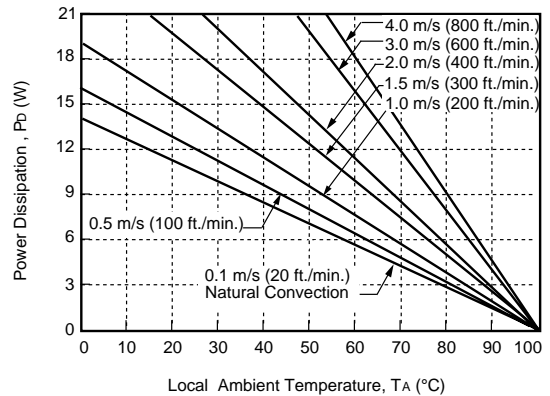

Fig.28 Forced Convection Power Derating without Heat Sink

AEH Half-Brick Power Converters 36VDC to 75VDC Input, 2.5V Output, 50-150W

Convection Without Heat Sinks

Heat transfer can be enhanced by increasing the airflow over the module. Figure 28 shows the maximum power that can be dissipated by the module.

In the test, natural convection airflow was measured at 0.05 m/s to 0.1 m/s (10 ft./min. to 20 ft./min.). The 0.5 m/s to 4.0 m/s (100 ft./min. to 800 ft./min.) curves are tested with externally adjustable fans. The appropriate airflow for a given operating condition can be determined through figure 28.

Example 1. How to calculate the minimum airflow required to maintain a desired T_c?

If a AEH30G48 module operates with a 48V line voltage, a 30 A output current, and a 40 °C maximum ambient temperature, What is the minimum airflow necessary for the operating?

Determine P_D (referenced Fig.26) with condition:

$$V_{in} = 48 \text{ V}$$

$$I_o = 30 \text{ A}$$

Get: P_D = 13.5 W

And with T_A = 40 °C

Determine airflow (Fig.28.):

$$v = 1.5 \text{ m/s (300 ft./min.)}$$

Example 2. How to calculate the maximum output power of a module in a certain convection and a max. T_A?

What is the maximum power output for a AEH30G48 operating at following conditions:

$$V_{in} = 48 \text{ V}$$

$$V = 1.5 \text{ m/s (300 ft./min.)}$$

$$T_A = 40 \text{ °C}$$

Determine P_D (Fig.28)

$$P_D = 14.5 \text{ W}$$

Determine I_o (Fig.26):

$$I_o = 30 \text{ A}$$

Calculate P_o:

$$P_o = (V_o) \times (I_o) = 2.5 \times 30 = 75 \text{ W}$$

Although the two examples above use 100 °C as the maximum case temperature, for extremely high reliability applications, one may design to a lower case temperature as shown in Example 4.

Heat Sink Configuration

Several standard heat sinks are available for the AEH 50 W to 150 W modules as shown in Figure 29 to Figure 31.

The heat sinks mount to the top surface of the module with screws torqued to 0.56 N-m (5 in.-

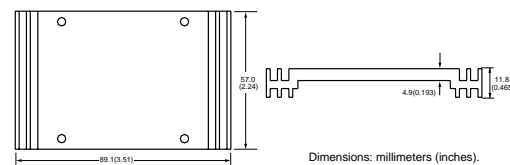

Fig.29 Non Standard Heatsink

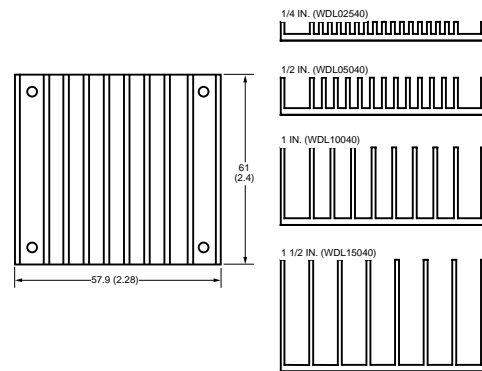

Fig.30 Longitudinal Fins Heat Sink

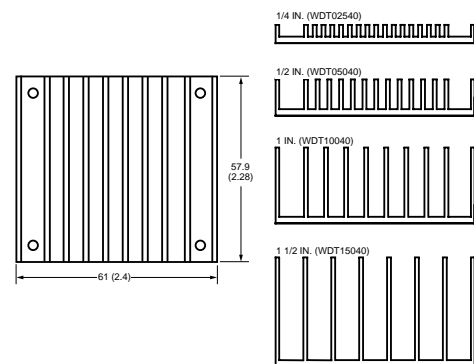

Fig.31 Transverse Fins Heat Sink

AEH Half-Brick Power Converters
36VDC to 75VDC Input, 2.5V Output, 50-150W

lb). A thermally conductive dry pad or thermal grease is placed between the case and the heat sink to minimize contact resistance (typically 0.1°C/W to 0.3°C/W) and temperature differential.

Nomenclature for heat sink configurations is as follows:

WDxyyy40

where:

x = fin orientation: longitudinal (L) or transverse (T)

yyy = heat sink height (in 100ths of inch)

For example, WDT5040 is a heat sink that is transverse mounted (see Figure 31) for a 61 mm x 57.9 mm (2.4 in. x 2.28 in.) module with a heat sink height of 0.5 in.

Heatsink Mounting Advice

A crucial part of the thermal design strategy is the thermal interface between the baseplate of the module and the heatsink. Inadequate measures taken here will quickly negate any other attempts to control the baseplate temperature. For example, using a conventional dry insulator can result in a case-heatsink thermal impedance of >0.5°C/W, while use one of the recommended interface methods (silicon grease or thermal pads available from Astec) can

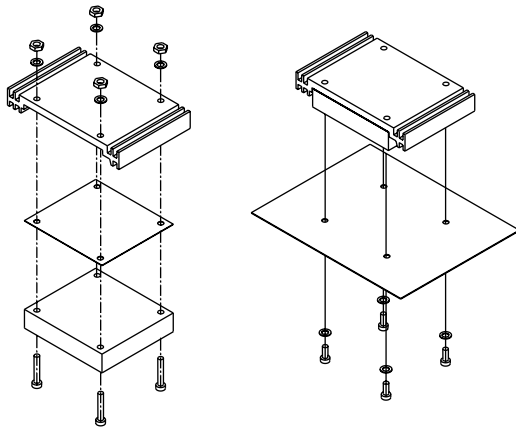

Fig.32 Heat Sink Mounting

result in a case-heatsink thermal impedance around 0.1°C/W.

Natural Convection with Heat Sink

The power derating for a module with the heat sinks (shown as figure 23 to figure 26) in natural convection is shown in figure 33. In this test, natural convection generates airflow about 0.05 m/s to 0.1 m/s (10ft./min to 20ft./min).

Figure 33 can be used for heat-sink selection in natural convection environment.

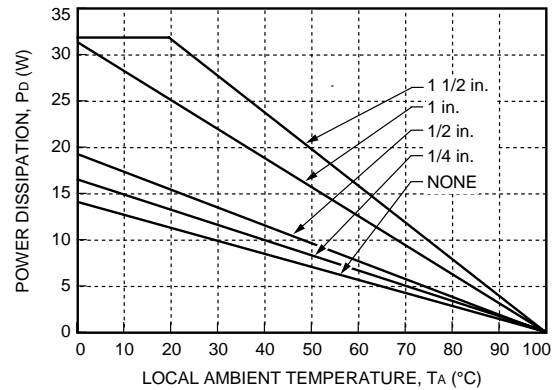

Fig.33 Heat Sink Power Derating Curves, Natural Convection

Example 3. How to select a heat sink?

What heat sink would be appropriate for a AEH30G48 in a natural convection environment at nominal line, 2/3 load, and maximum ambient temperature of 40°C?

Determine Pd (referenced Fig.26) with condition:

$$V_{in} = 48 \text{ V}$$

$$I_o = 2/3 (30) = 20 \text{ A}$$

$$T_A = 40 \text{ }^\circ\text{C}$$

Get: $P_D = 7.5 \text{ W}$

Determine Heat Sink (Fig.33.):

no heat sink allows up to $T_A = 50 \text{ }^\circ\text{C}$

1/4 in. allows up to $T_A = 60 \text{ }^\circ\text{C}$

AEH Half-Brick Power Converters
36VDC to 75VDC Input, 2.5V Output, 50-150W

Basic Thermal Model

There is another approach to analyze module thermal performance, to model the overall thermal resistance of the module. This presentation method is especially useful when considering heat sinks. The following equation can be used to calculate the total thermal resistance .

$$RCA = \Delta T_{C, \max} / P_D$$

Where RCA is the module thermal resistance,

$\Delta T_{C, \max}$ is the maximum case temperature rise,

P_D is the module power dissipation.

In this model, P_D , $\Delta T_{C, \max}$, and RCA are equals to current flow, voltage drop, and electrical resistance, respectively, in Ohm's law, as shown in Figure 34. Also, $\Delta T_{C, \max}$ is defined as the difference between the module case temperature (T_C) and the inlet ambient temperature (T_A).

$$\Delta T_{C, \max} = T_C - T_A$$

Where T_C is the module case temperature;

T_A is the inlet ambient temperature.



Fig.34 Basic Thermal Resistance Model

For AEH Series 50W to 150W 2.5V output converters, the module's thermal resistance values versus air velocity have been determined experimentally and shown in figure 35. The highest values on each curve represents the point of natural convection.

Figure 35 is used for determining thermal performance under various conditions of airflow and heat sink configurations.

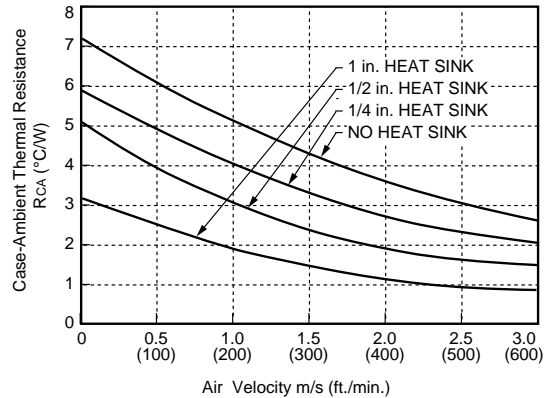

Fig.35. Case-to-Ambient Thermal Resistance Curves; Either Orientation

Example 4. How to determine the allowable minimum airflow to heat sink combinations necessary for a module under a desired T_C and a certain condition?

Although the maximum case temperature for the AEH Series converters is 100°C, you can improve module reliability by limiting $T_{C, \max}$ to a lower value. How to decide? For example, what is the allowable minimum airflow for AEH 150W heat sink combinations at desired T_C of 80 °C?

The working condition is as following:

$$V_{in} = 48 \text{ V, } I_o = 30 \text{ A, } T_A = 40 \text{ °C}$$

Determine P_D (Fig.26)

$$P_D = 13.5 \text{ W}$$

Then solve RCA:

$$RCA = \Delta T_{C, \max} / P_D$$

$$RCA = (T_C - T_A) / P_D$$

$$RCA = (80 - 40) / 13.5 = 3^\circ\text{C/W}$$

determine air velocity from figure 35:

If no heat sink:

$$v = 2.6 \text{ m/s (520 ft./min.)}$$

If 1/4 in. heat sink:

$$v = 1.8 \text{ m/s (360 ft./min.)}$$

If 1/2 in. heat sink:

$$v = 1.1 \text{ m/s (220 ft./min.)}$$

If 1 in. heat sink:

$$v = 0.4 \text{ m/s (80 ft./min.)}$$

Example 5. How to determine case temperature (T_c) for the various heat sink configurations at certain air velocity?

What is the allowable T_c for AEH 150W heat sink configurations at desired air velocity of 2.0 m/s, and it is operating at a 48 V line voltage, a 30 A output current, a 40 °C maximum ambient temperature?

Determine P_D (Fig.26) with condition:

$$V_{in} = 48 \text{ V}$$

$$I_O = 30 \text{ A}$$

$$T_A = 40 \text{ }^\circ\text{C}$$

$$v = 2.0 \text{ m/s (400 ft./min.)}$$

Get: P_D = 13.5 W

Determine T_c: $T_c = (RCA \times P_D) + T_A$

Determine the corresponding thermal resistances (RCA) from Figure 35:

No heat sink: RCA = 3.8 °C/W

$$T_c = (3.8 \times 13.5) + 40 = 91 \text{ }^\circ\text{C}$$

1/4 in. heat sink: RCA = 2.8 °C/W

$$T_c = (2.8 \times 13.5) + 40 = 78 \text{ }^\circ\text{C}$$

1/2 in. heat sink: RCA = 2.0 °C/W

$$T_c = (2.0 \times 13.5) + 40 = 66 \text{ }^\circ\text{C}$$

1 in. heat sink: RCA = 1.2 °C/W

$$T_c = (1.2 \times 13.5) + 40 = 56 \text{ }^\circ\text{C}$$

In this configuration, the heat sink would not need and the power module does not exceed the maximum case temperature of 100°C.

ment life spans.

Soldering

AEH series converters are compatible with standard wave soldering techniques. When wave soldering, the converter pins should be preheated for 20-30 seconds at 110°C, and wave soldered at 260°C for less than 10 seconds.

When hand soldering, the iron temperature should be maintained at 425°C and applied to the converter pins for less than 5 seconds. Longer exposure can cause internal damage to the converter. Cleaning can be performed with cleaning solvent IPA or with water.

MTBF

The MTBF, calculated in accordance with Bellcore TR-NWT-000332 is 2,080,000 hours. Obtaining this MTBF in practice is entirely possible. If the ambient air temperature is expected to exceed +25°C, then we also advise a heatsink on the AEH, oriented for the best possible cooling in the air stream.

ASTECCAN supply replacements for converters from other manufacturers, or offer custom solutions. Please contact the factory for details.

AEH Series Mechanical Considerations

Installation

Although AEH series converters can be mounted in any orientation, free air-flowing must be taken. Normally power components are always put at the end of the airflow path or have the separate airflow paths. This can keep other system equipment cooler and increase compo-

AEH Half-Brick Power Converters
36VDC to 75VDC Input, 2.5V Output, 50-150W

Recommend Hole Pattern

Base-plate side view

Dimensions are in millimeters and (inches).

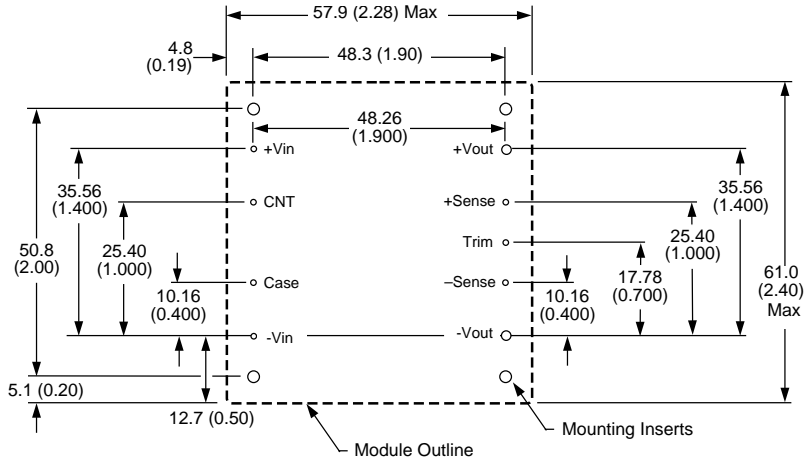

Mechanical Chart

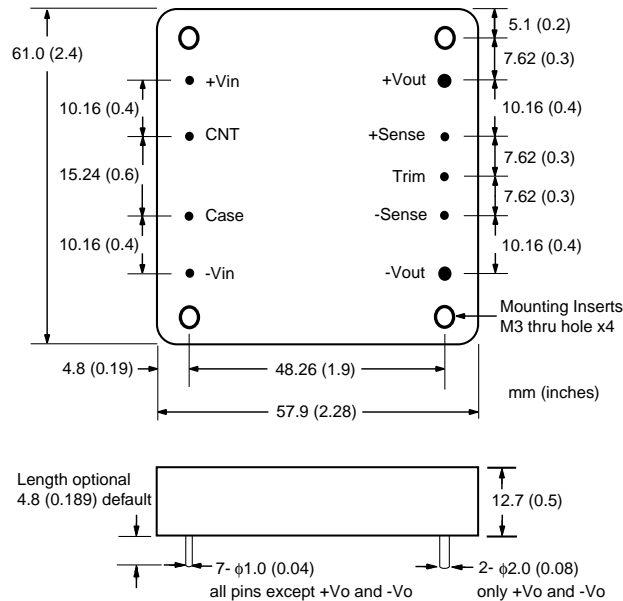

Pin Length Option	Device Code Suffix
4.80mm ± 0.5mm 0.189in. ± 0.020in.	none (default)
3.80mm ± 0.25mm 0.150in. ± 0.010in.	-6
5.80mm ± 0.5mm 0.228in. ± 0.02in.	-7
2.80mm ± 0.25mm 0.110in. ± 0.010in.	-8

Tolerances:
 Inches .xx ±0.020
 .xxx ±0.010
 Millimeters .x ±0.5
 .xx ±0.25

Pins
 >4mm ±0.02inch (±0.5mm)
 <4mm ±0.01inch (±0.25mm)

Base-plate side view

PART NUMBER DESCRIPTION

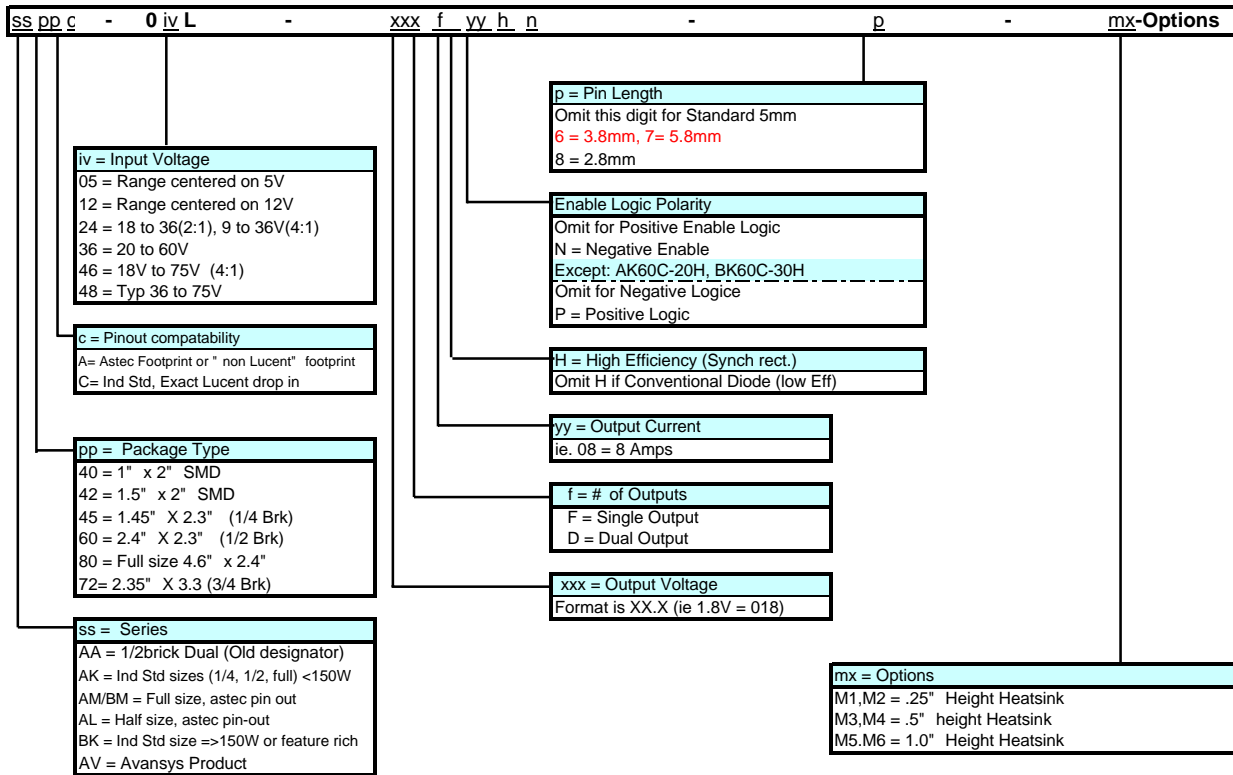

Note: For some products, they may not conform with the PART NUMBER DESCRIPTION above absolutely.

NEW PART NUMBER DESCRIPTION

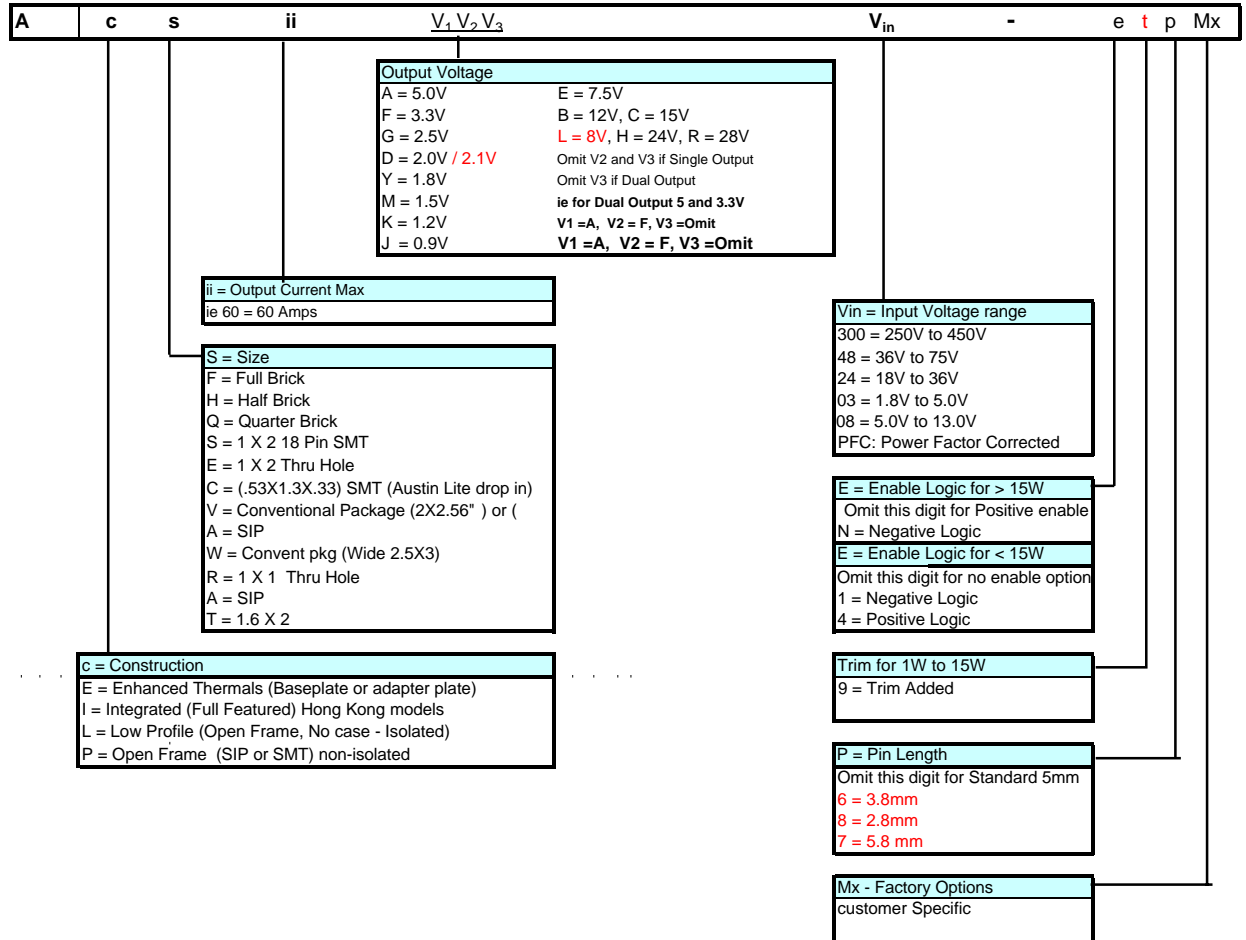

Note: For some products, they may not conform with the NEW PART NUMBER DESCRIPTION above absolutely.