

Version :1.0

<p>TECHNICAL SPECIFICATION</p> <p>MODEL NO. : PD121XL6</p>
--

The content of this information is subject to be changed without notice.
Please contact PVI or its agent for further information.

Customer's Confirmation



Customer _____

Date _____

By _____

PVI's Confirmation

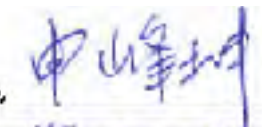
FOR MORE INFORMATION:
AZ DISPLAYS, INC.
75 COLUMBIA, ALISO VIEJO, CA 92656
[Http://www.AZDISPLAYS.com](http://www.AZDISPLAYS.com)

Confirmed By 
Prepared By 

Revision History

Rev.	Eng.	Issued Date	Revised Contents
0.1	Sarah Huang	Jan 16, 2009	Preliminary
1.0	Sarah Huang	Jan 07, 2010	Modify Page 7 5. Input / Output Terminals Add Page 8 6-1) Pin assignment: Modify Page 17 14. Optical Characteristics: Uniformity from 75% to 70% Add Page 17 14. Optical Characteristics: White Chromaticity Add Page 22 17. Packing Diagram

TECHNICAL SPECIFICATION**CONTENTS**

NO.	ITEM	PAGE
-	Cover	1
-	Revision History	2
-	Contents	3
1	Application	4
2	Features	4
3	Mechanical Specifications	4
4	Mechanical Drawing of TFT-LCD Module	5
5	Input / Output Terminals	7
6	Touch Panel Characteristics	8
7	Absolute Maximum Ratings	10
8	Electrical Characteristics	10
9	Pixel Arrangement	11
10	Display Color and Gray Scale Reference	12
11	Block Diagram	13
12	Interface Timing	14
13	Power On Sequence	16
14	Optical Characteristics	17
15	Handling Cautions	20
16	Reliability Test	21
17	Packing Diagram	22

1. Application

The PD121XL6 is a 12.1" TFT-LCD module with LED B/L and a 20-pin LVDS interface. This module supports 1024 x768 XGA modes and displays 262,144 colors. This module can apply TFT-LCD monitor, TV, Factory application, Amusement Vehicle, and so on.

2. Features

- Wide viewing angle
- Fast response time
- High color saturation
- XGA (1024 x768 pixels) resolution
- Wide operating temperature
- DE (Data Enable) mode
- LVDS (Low Voltage Differential Signaling) interface
- RoHS Compliance
- Module with resistive type touch panel.

3. Mechanical Specifications

Parameter	Specifications	Unit
Screen Size	12.1 (diagonal)	inch
Display Format	1024×(R, G, B)×768	dot
Display Colors	262,144	
Active Area	245.76(H)×184.32(V)	mm
Pixel Pitch	0.240(H)×0.240(V)	mm
Pixel Configuration	RGB Vertical Stripe	
Outline Dimension	260.5(W)× 204(H)× 9.76(D) (typ.)	mm
Weight	715±20	g
Back-light	54-LED	
Surface treatment	Anti-glare + WV film	
Display mode	Normally White	
Surface treatment of Touch Panel	3H	
Gray scale inversion direction	12 O'clock	Note 14-2

4. Mechanical Drawing of TFT-LCD Module

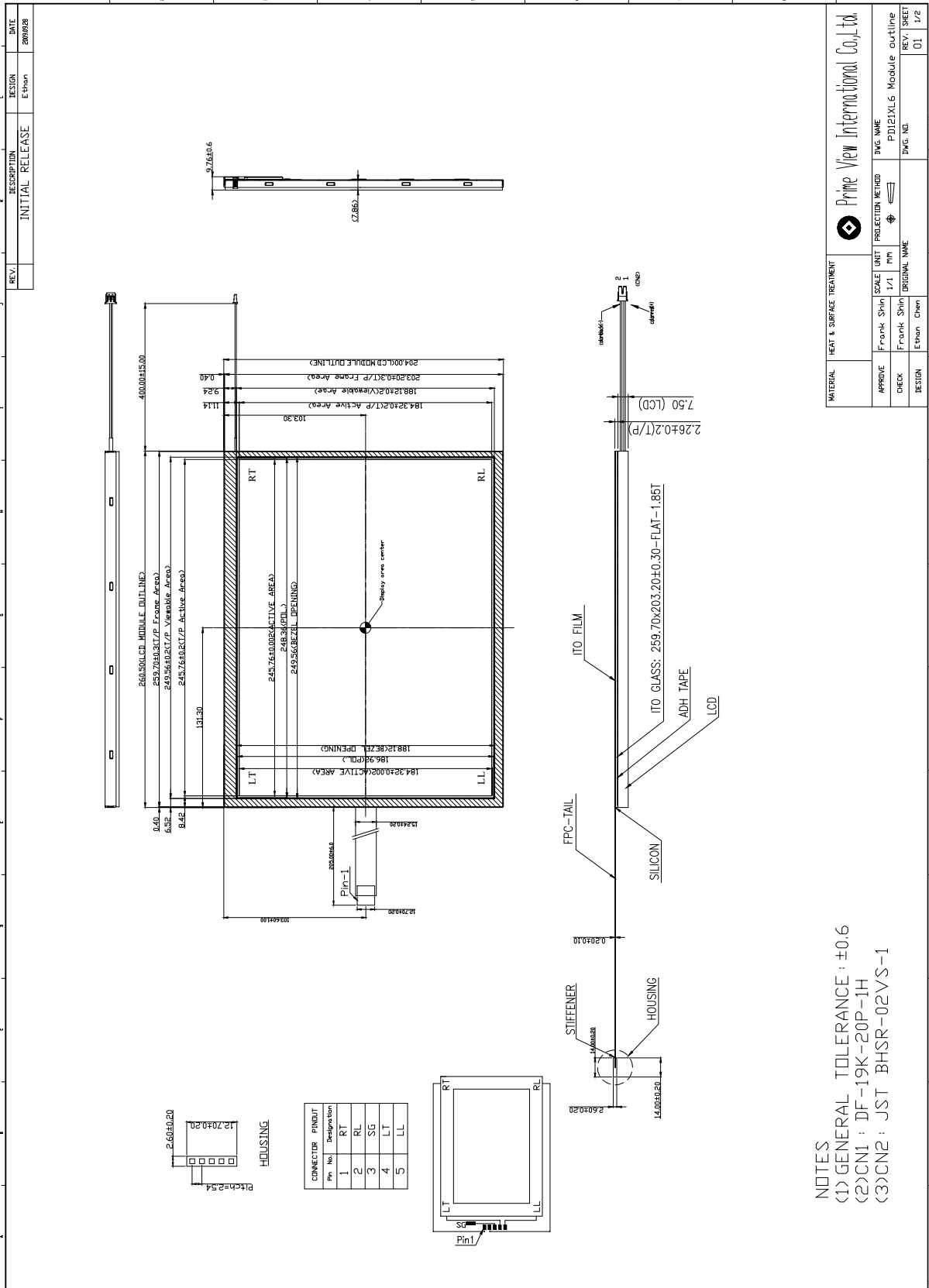

MATERIAL	HEAT & SURFACE TREATMENT	PRIME VIEW INTERNATIONAL CO., LTD.			
APPROVE	FRANK SHIH	SCALE	UNIT	PROJECTION METHOD	DWG. NAME
CHECK	FRANK SHIH	1/1	mm	1st	PD121XL6 Module outline
DESIGN	ETIEN CHEN	ORIGINAL NAME			
		DWG. NO.			REV. SHEET
					01 1/2

NOTES
 (1) GENERAL TOLERANCE : ±0.6
 (2) CN1 : DF-19K-20P-1H
 (3) CN2 : JST BHSR-02VS-1

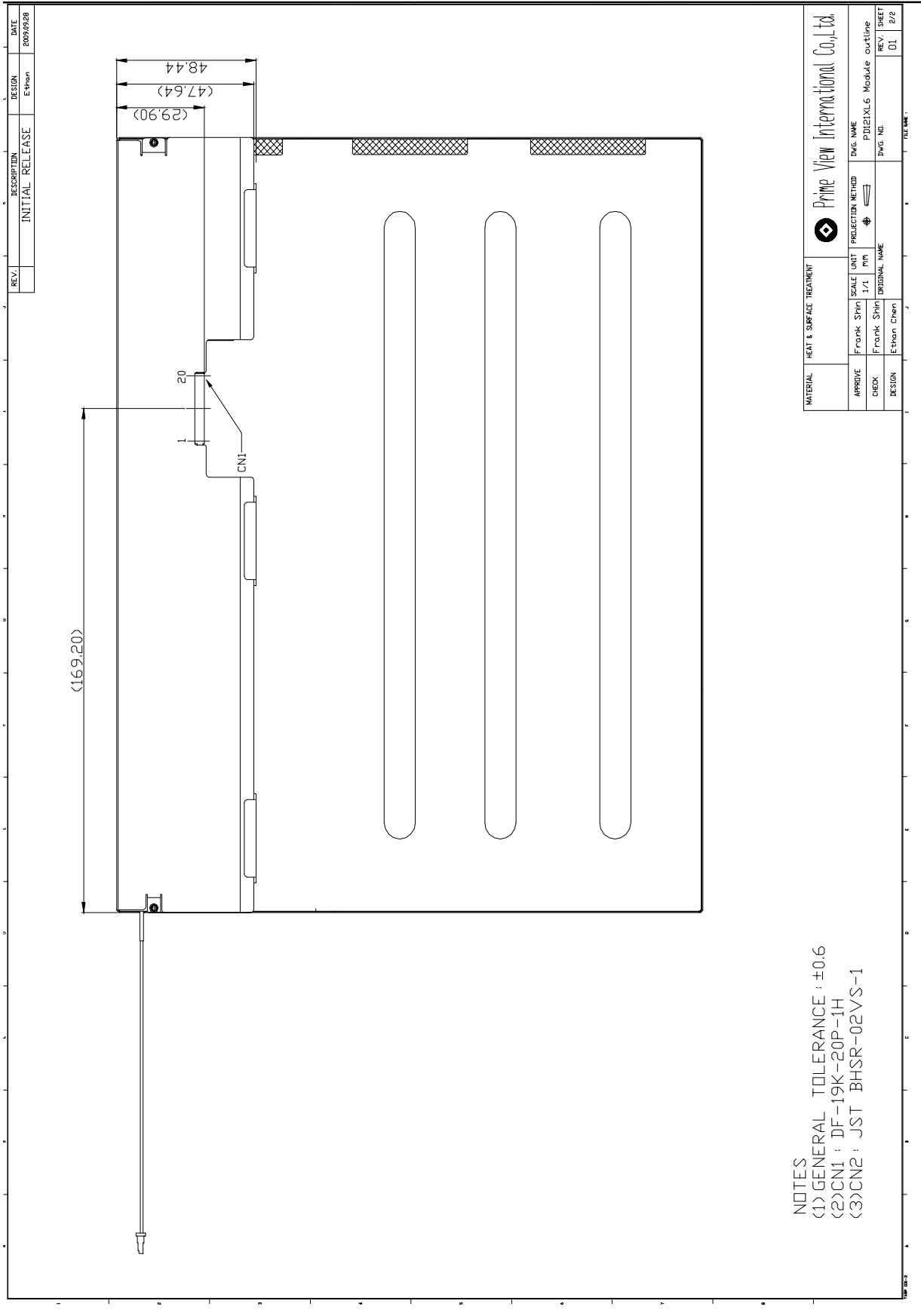

5. Input / Output Terminals

5-1) TFT-LCD Panel Driving

Connector type: DF19K-20P-1H

CN1	Interface connector	Hirose/DF19L-20P-1H or equivalent
	User side connector	Hirose/DF19G-20S-1C or equivalent

Pin No.	Symbol	Function	Remark
1	VSS	Ground	
2	VDD1	Power Supply: +3.3V	
3	VDD2	Power Supply: +3.3V	
4	NC	NC	
5	NC	NC	
6	NC	NC	
7	NC	NC	
8	RIN0-	LVDS Negative data signal (-)	Tx pin #48
9	RIN0+	LVDS Positive data signal (+)	Tx pin #47
10	VSS	Ground	
11	RIN1-	LVDS Negative data signal (-)	Tx pin #46
12	RIN1+	LVDS Positive data signal (+)	Tx pin #45
13	VSS	Ground	
14	RIN2-	LVDS Negative data signal (-)	Tx pin #42
15	RIN2+	LVDS Positive data signal (+)	Tx pin #41
16	VSS	Ground	
17	RCLKIN-	LVDS Negative clock signal (-)	Tx pin #40
18	RCLKIN+	LVDS Positive clock signal (+)	Tx pin #39
19	VSS	Ground	
20	VSS	Ground	

5-2) Backlight driving

Connector type: JST BHSR-02VS-1, PIN No 2 pin

Pin No	Symbol	Description	Remark
1	+	Input terminal (Anode)	Wire color: Red
2	-	Input terminal (Cathode)	Wire Color: Black

5-3) LVDS Interface

LVDS Transmitter: THC63LVDM83A or equivalent

Input signal	Transmitter		Interface	
	Pin No	Pin No	System (Tx)	TFT-LCD (Rx)
R0	51	48 47	OUT0- OUT0+	IN0- IN0+
R1	52			
R2	54			
R3	55			
R4	56			
R5	3			
G0	4	46 45	OUT1- OUT1+	IN1- IN1+
G1	6			
G2	7			
G3	11			
G4	12			
G5	14			
B0	15	42 41	OUT2- OUT2+	IN2- IN2+
B1	19			
B2	20			
B3	22			
B4	23			
B5	24			
HSYNC	27	40	CLKOUT-	CLKIN-
VSYNC	28			
DE	30			
MCLK	31	39	CLKOUT+	CLKIN+

6. Touch Panel Characteristics

6-1) Pin assignment:

Pin No.	Symbol	Function	Remark
1	RT	Loop Resistance	Note 6-1
2	RL	Loop Resistance	Note 6-1
3	SG	GND	
4	LT	Loop Resistance	Note 6-1
5	LL	Loop Resistance	Note 6-1

Note 6 - 1:

Loop Resistance X = short RT and RL , short LT and LL , measure the resistance between RT and LT
 Loop Resistance Y = short RT and LT , short RL and LL ,measure the resistance between RT and RL

6-2) Electrical Performances:

Parameters	Symbol	MIN.	Typ.	MAX.	Unit	Remark
Terminal Resistance	X	20	-	500		
	Y	20	-	500		
Input Voltage	VT	-	5	-	V	
Linearity(X ,Y direction)		-	-	±1.5	%	
Insulation Impedance		20	-	-	MΩ	DC= 25V
Response Time		-	-	15	ms	
Operation Force		-	-	80	g	Note 6-2

Note 6 - 2: Input through R0.8mm stylus or R8.0mm finger.

6-3) Durability Performances

1) Hitting Durability:

At least 10,000,000 times with R8.0mm silicon rubber, 150g, 3times/sec .

2) Sliding Durability:

At least 100,000 times with R0.8mm polydactyl stylus, 150g, 50mm/sec.

6-4) Integration Design Guide

Avoid the design that Front-case overlap and press on the active area of the touch-panel.
Give enough gap (over 0.5mm at compressed) between the front case and touch-panel to protect wrong operating.

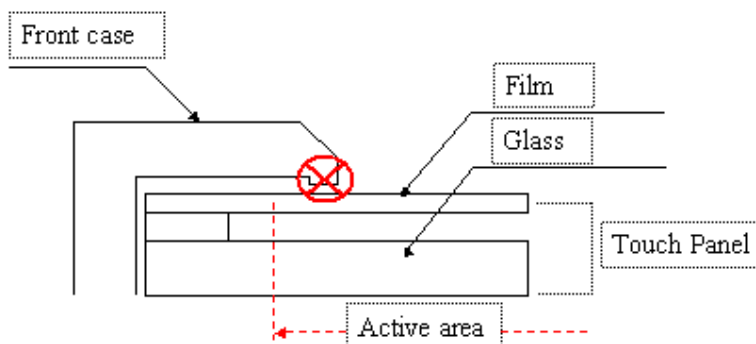

Use a buffer material (Gasket) between the touch-panel and front-case to protect damage and wrong operating.

Avoid the design that buffer material overlap and press on the inside of touch-panel viewing area.

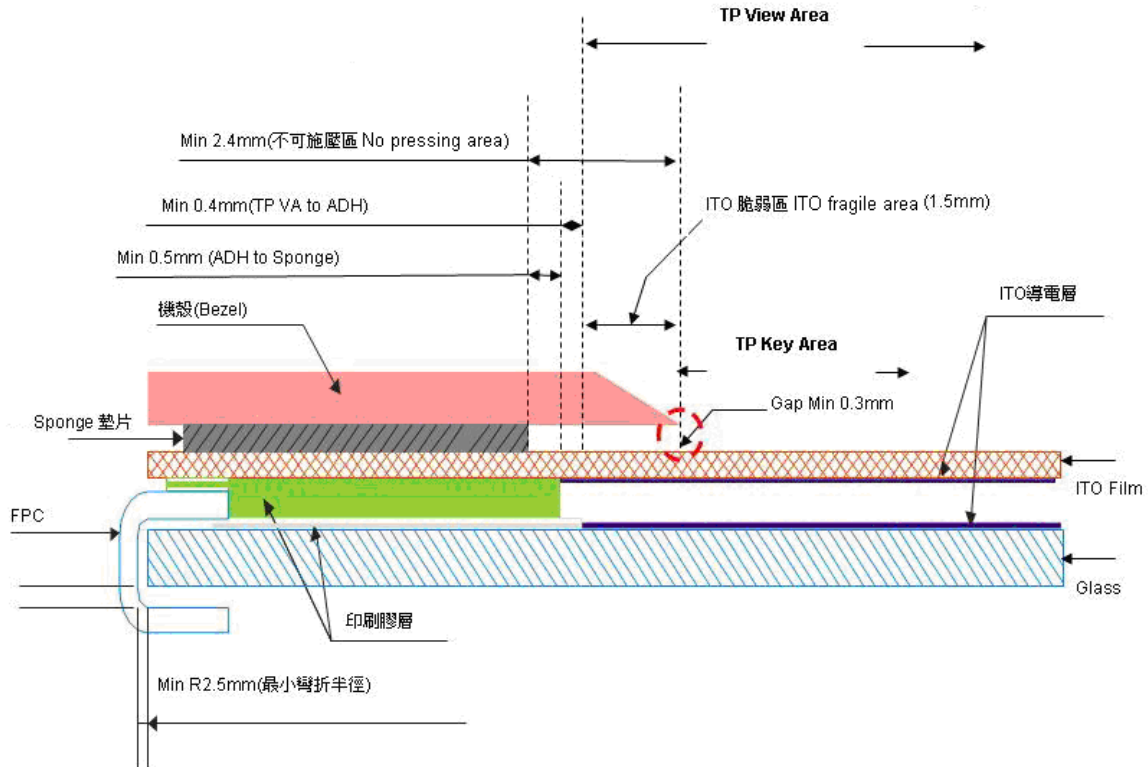

Note: We strongly suggest to follow above design guide to avoid the linear defect happened on the touch panel.

7. Absolute Maximum Ratings:

The followings are maximum values, which if exceeded, may cause faulty operation or damage to the unit. GND=0V, Ta=25°C

Parameters	Symbol	MIN.	MAX.	Unit	Remark
Logic Power Supply	V _{DD}	VSS-0.3	+4.0	V	
Logic Input Voltage	V _{IN}	VSS-0.3	V _{DD} +0.3	V	Note 7-1

Note 7-1: Permanent damage to the device may occur if maximum values are exceeded. Function operation should be restricted to the conditions described under Normal Operating Conditions.

8. Electrical Characteristics

8-1) Recommended Operating Conditions:

Ta=25 ± 2°C

Parameter	Symbol	Value			Unit	Note
		Min.	Typ.	Max.		
Power Supply Voltage	V _{DD}	3.0	3.3	3.6	V	Note 8-1
Power Supply Current	I _{DD}	-	280	485	mA	
Power Consumption	P _{DD}	-	0.9	1.6	W	Note 8-2
LVDS differential voltage	V _{ID}	-100	-	+100	mV	
LVDS common input voltage	V _{ic}	-	1.2	-	V	

Note 8-1: The module is recommended to operate within specification ranges listed above for normal function.

Note 8-2: P_{DD}=V_{DD} × I_{DD}

8-2) Recommended driving condition for LED backlight:

Ta = 25°C

Parameter	Symbol	Min	TYP	MAX	Unit	Remark
Supply voltage of LED backlight	V _{LED1}	-	9.9	(10.8)	V	Note 8-3
Supply current of LED backlight	I _{LED1}	-	20	-	mA	Note 8-4
Backlight Power Consumption	P _{LED}	-	3.56	(3.89)	W	Note 8-3/8-5

Note 8-3: I_{LED} = 20mA, Constant Current.

Note 8-4: The LED driving condition is defined for each LED module. (3 LED Serial)
Input current = 360mA

Note 8-5: P_{LED} = V_{LED1} * I_{LED1} + V_{LED2} * I_{LED2} + + V_{LED17} * I_{LED17} + V_{LED18} * I_{LED18}

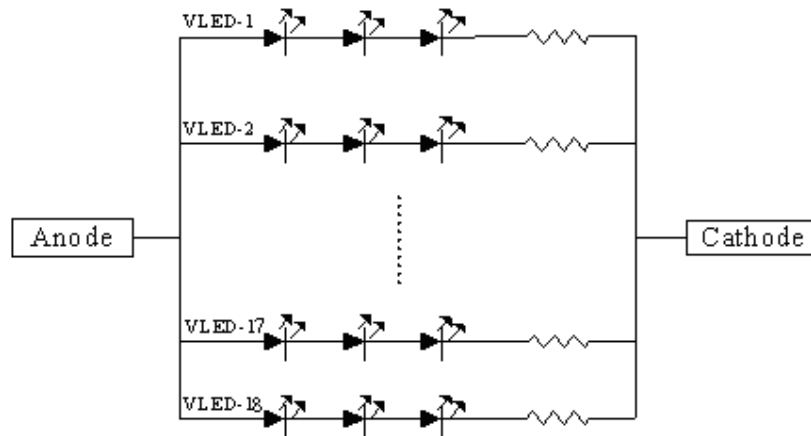

9. Pixel Arrangement

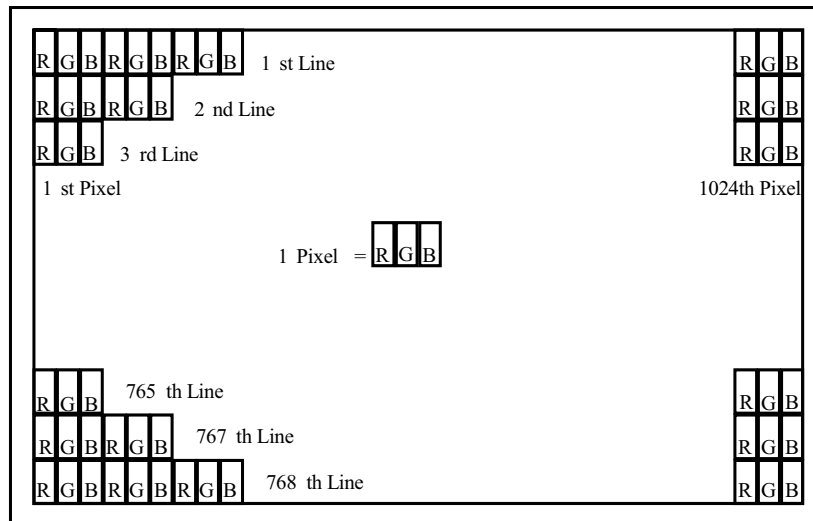

10. Display Color and Gray Scale Reference

Color		Data Signal																	
		Red					Green					Blue							
		R5	R4	R3	R2	R1	R0	G5	G4	G3	G2	G1	G0	B5	B4	B3	B2	B1	B0
Basic Colors	Black	0	0	0	0	0	0	0	0	0	0	0	0	0	0	0	0	0	0
	Red	1	1	1	1	1	1	0	0	0	0	0	0	0	0	0	0	0	0
	Green	0	0	0	0	0	0	1	1	1	1	1	1	0	0	0	0	0	0
	Blue	0	0	0	0	0	0	0	0	0	0	0	0	1	1	1	1	1	1
	Cyan	0	0	0	0	0	0	1	1	1	1	1	1	1	1	1	1	1	1
	Magenta	1	1	1	1	1	1	0	0	0	0	0	0	1	1	1	1	1	1
	Yellow	1	1	1	1	1	1	1	1	1	1	1	1	0	0	0	0	0	0
	White	1	1	1	1	1	1	1	1	1	1	1	1	1	1	1	1	1	1
Gray Scale Of Red	Red(0)/Dark	0	0	0	0	0	0	0	0	0	0	0	0	0	0	0	0	0	0
	Red(1)	0	0	0	0	0	1	0	0	0	0	0	0	0	0	0	0	0	0
	Red(2)	0	0	0	0	1	0	0	0	0	0	0	0	0	0	0	0	0	0
	:	:	:	:	:	:	:	:	:	:	:	:	:	:	:	:	:	:	:
	:	:	:	:	:	:	:	:	:	:	:	:	:	:	:	:	:	:	:
	:	:	:	:	:	:	:	:	:	:	:	:	:	:	:	:	:	:	:
	Red(61)	1	1	1	1	0	1	0	0	0	0	0	0	0	0	0	0	0	0
	Red(62)	1	1	1	1	1	0	0	0	0	0	0	0	0	0	0	0	0	0
Red(63)	1	1	1	1	1	1	0	0	0	0	0	0	0	0	0	0	0	0	
Gray Scale Of Green	Green(0)/Dark	0	0	0	0	0	0	0	0	0	0	0	0	0	0	0	0	0	0
	Green(1)	0	0	0	0	0	0	0	0	0	0	1	0	0	0	0	0	0	0
	Green(2)	0	0	0	0	0	0	0	0	0	1	0	0	0	0	0	0	0	0
	:	:	:	:	:	:	:	:	:	:	:	:	:	:	:	:	:	:	:
	:	:	:	:	:	:	:	:	:	:	:	:	:	:	:	:	:	:	:
	:	:	:	:	:	:	:	:	:	:	:	:	:	:	:	:	:	:	:
	Green(61)	0	0	0	0	0	0	1	1	1	1	0	1	0	0	0	0	0	0
	Green(62)	0	0	0	0	0	0	1	1	1	1	1	0	0	0	0	0	0	0
Green(63)	0	0	0	0	0	0	1	1	1	1	1	1	0	0	0	0	0	0	
Gray Scale Of Blue	Blue(0)/Dark	0	0	0	0	0	0	0	0	0	0	0	0	0	0	0	0	0	0
	Blue(1)	0	0	0	0	0	0	0	0	0	0	0	0	0	0	0	0	0	1
	Blue(2)	0	0	0	0	0	0	0	0	0	0	0	0	0	0	0	0	1	0
	:	:	:	:	:	:	:	:	:	:	:	:	:	:	:	:	:	:	:
	:	:	:	:	:	:	:	:	:	:	:	:	:	:	:	:	:	:	:
	:	:	:	:	:	:	:	:	:	:	:	:	:	:	:	:	:	:	:
	Blue(61)	0	0	0	0	0	0	0	0	0	0	0	1	1	1	1	1	0	1
	Blue(62)	0	0	0	0	0	0	0	0	0	0	0	1	1	1	1	1	1	0
Blue(63)	0	0	0	0	0	0	0	0	0	0	0	1	1	1	1	1	1	1	
Gray Scale Of Black	Black(0)/Dark	0	0	0	0	0	0	0	0	0	0	0	0	0	0	0	0	0	0
	Gray (1)	0	0	0	0	0	1	0	0	0	0	1	0	0	0	0	0	0	1
	Gray (2)	0	0	0	0	1	0	0	0	0	1	0	0	0	0	0	0	1	0
	:	:	:	:	:	:	:	:	:	:	:	:	:	:	:	:	:	:	:
	:	:	:	:	:	:	:	:	:	:	:	:	:	:	:	:	:	:	:
	:	:	:	:	:	:	:	:	:	:	:	:	:	:	:	:	:	:	:
	Gray (61)	1	1	1	1	0	1	1	1	1	1	0	1	1	1	1	1	0	1
	Gray (62)	1	1	1	1	1	0	1	1	1	1	1	0	1	1	1	1	1	0
White(63)	1	1	1	1	1	1	1	1	1	1	1	1	1	1	1	1	1	1	

Note 10-1: 0: Low Level Voltage, 1: High Level Voltage

11. Block Diagram

11-1) TFT-module Block Diagram

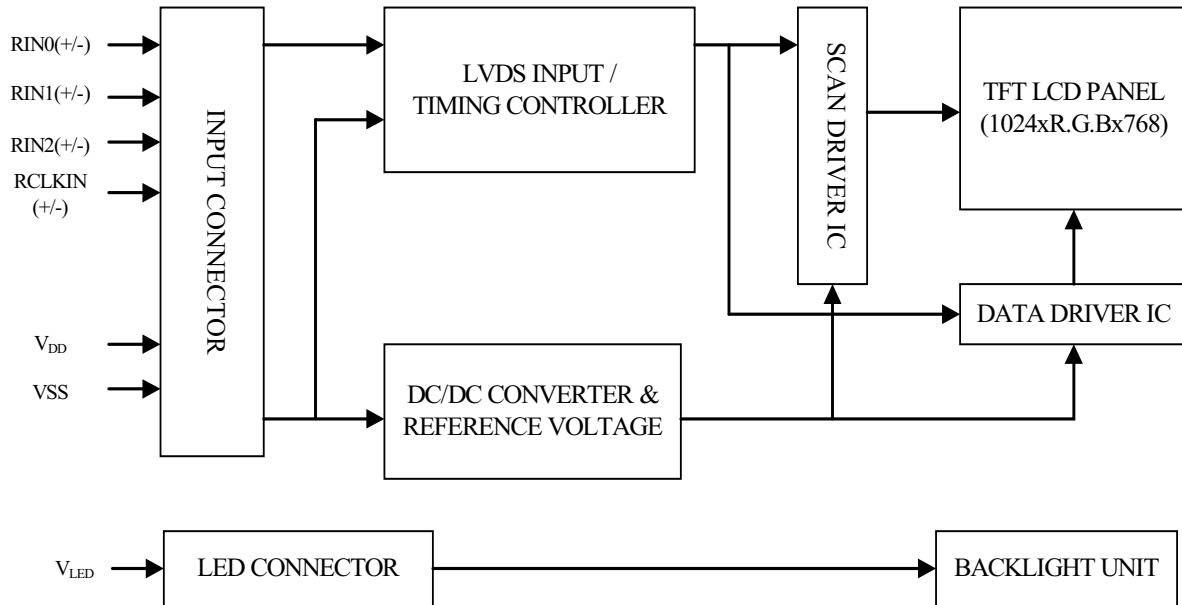

12. Interface Timing

12-1) The 12.1" XGA LCM is operated by the only DE mode (LVDS Transmitter Input)

Item	Symbols	Min	Typ	Max	Unit	
Clock	Frequency	1/Tc	-	65	80	MHz
	High Time	Tch	4.5	-	-	ns
	Low Time	Tcl	4.5	-	-	ns
Data	Setup Time	Tds	2.7	-	-	ns
	Hold Time	Tdh	0	-	-	ns
Data Enable Setup Time	Tes	2.7	-	-	ns	
Frame Period	Tv	772	806	1022	lines	
Vertical Display Period	Tvd	768	768	768	lines	
One Line Scanning Period	Th	1100	1344	2046	clocks	
Horizontal Display Period	Thd	1024	1024	1024	clocks	

12-2) LVDS Rx interface timing parameter

The specification of the LVDS Rx interface timing parameter

Item	Symbol	Min	Typ	Max	Unit	Remark
CLKIN Period	tRCIP	12.5	15.38		nsec	
Input Data 0	tRIP0	-0.4	0.0	+0.4	nsec	
Input Data 1	tRIP1	tRCIP/7-0.4	tRCIP/7	tRCIP/7+0.4	nsec	
Input Data 2	tRIP2	2 × tRCIP/7-0.4	2 × tRCIP/7	2 × tRCIP/7+0.4	nsec	
Input Data 3	tRIP3	3 × tRCIP/7-0.4	3 × tRCIP/7	3 × tRCIP/7+0.4	nsec	
Input Data 4	tRIP4	4 × tRCIP/7-0.4	4 × tRCIP/7	4 × tRCIP/7+0.4	nsec	
Input Data 5	tRIP5	5 × tRCIP/7-0.4	5 × tRCIP/7	5 × tRCIP/7+0.4	nsec	
Input Data 6	tRIP6	6 × tRCIP/7-0.4	6 × tRCIP/7	6 × tRCIP/7+0.4	nsec	

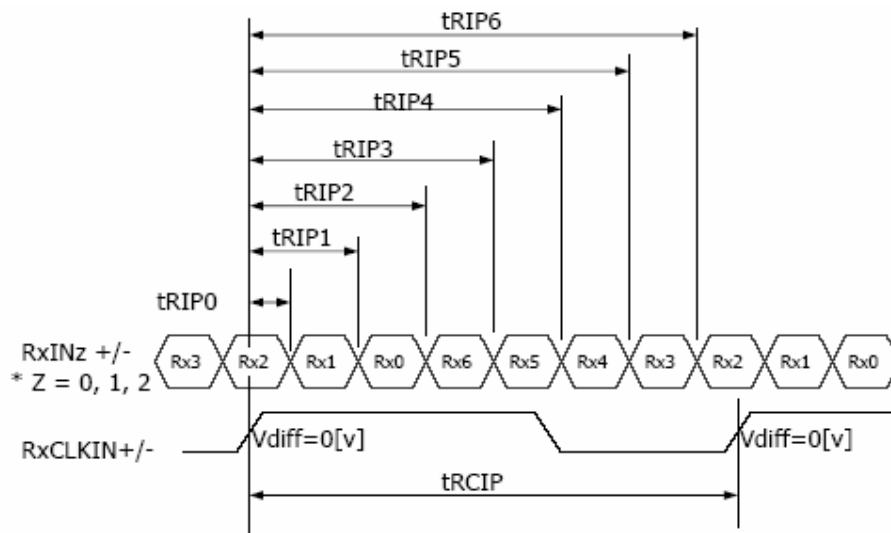

$$* V_{diff} = (RINz+) - (RINz-), (RCLKIN+) - (RCLKIN-)$$

12-3) Signal Timing Waveforms of Interface Signal (DE Mode)

A) Vertical Timing Waveforms

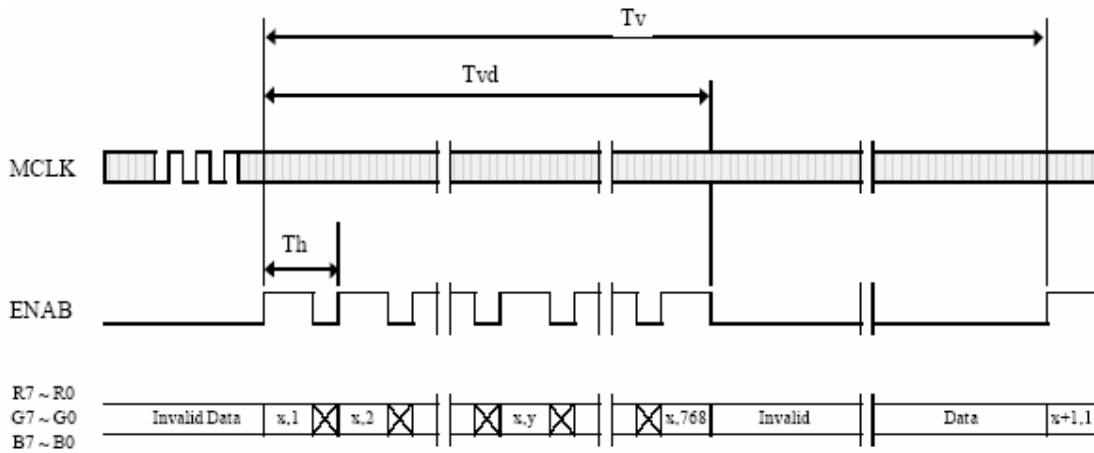

B) Horizontal Timing Waveforms

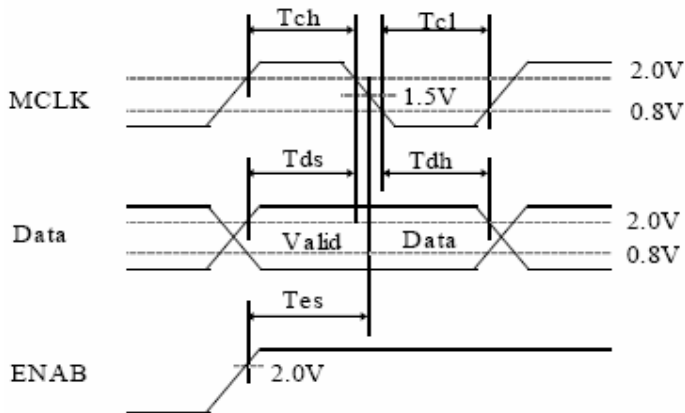
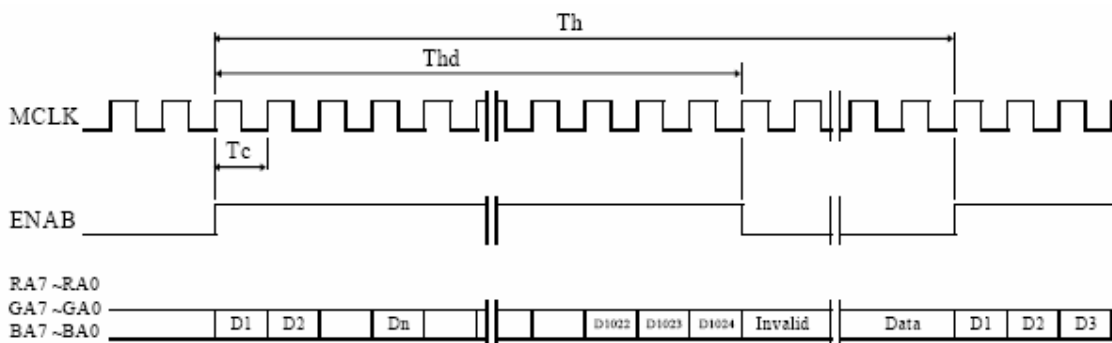

13. Power on Sequence

To prevent a latch-up or DC operation of the LCD module, the power on/off sequence shall be as shown in below

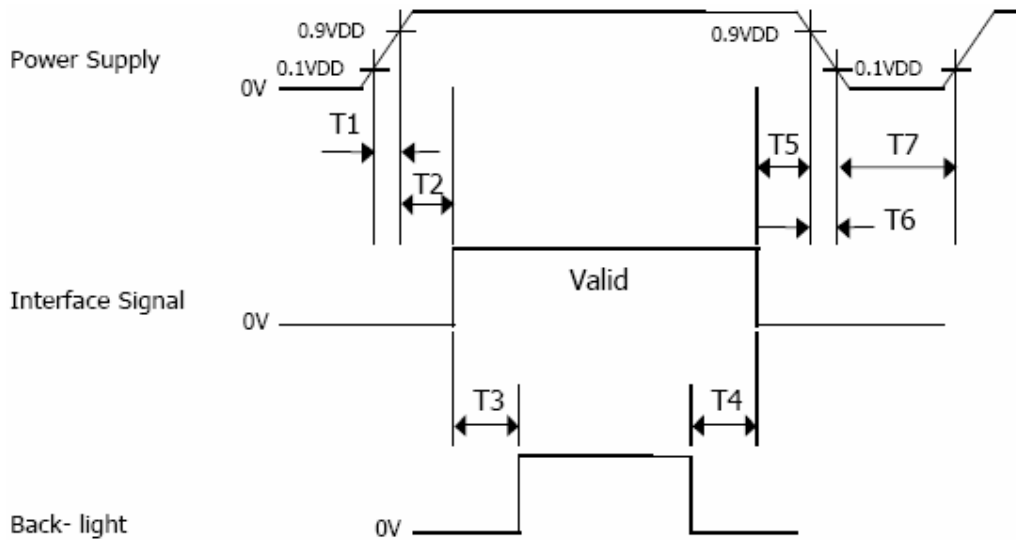

- $0 < T1 \leq 10 \text{ ms}$
- $0 < T2 \leq 50 \text{ ms}$
- $200 \text{ ms} \leq T3$
- $0 \text{ ms} \leq T4, 0 \text{ ms} \leq T5$
- $0 \leq T6 \leq 10 \text{ ms}$
- $150 \text{ ms} \leq T7$

Note 13-1: When the power supply VDD is 0V, keep the level of input signals on the low or keep high impedance.

Note 13-2: Do not keep the interface signal high impedance when power is on.

Note 13-3: Back Light must be turn on after power for logic and interface signal are valid.

14. Optical Characteristics

14-1) Specification:

Ta=25°C

Parameter	Symbol	Condition	MIN.	TYP.	MAX.	Unit	Remarks
Viewing Angle	Horizontal	θ	70	75	-	deg	Note 14-2
	Vertical	θ (to 12 o'clock)	50	55	-	deg	
		θ (to 6 o'clock)	40	45	-	deg	
Contrast Ratio	CR	$\theta = 0^\circ$	400	600	-	-	Note 14-3
Response time	Rise	Tr	-	10	20	ms	Note 14-5
	Fall	Tf	-	20	40	ms	
Brightness	L	$\theta = 0^\circ / \varphi = 0$	300	400	-	cd/m ²	Note 14-1
LED Life Time	-	-	20000	30000	-	hrs	Note 14-4
White Chromaticity	x	$\theta = 0^\circ / \varphi = 0$	0.26	0.31	0.36	-	Note 14-1
	y	$\theta = 0^\circ / \varphi = 0$	0.29	0.34	0.39	-	
Uniformity	U	-	65	70	-	%	Note 14-6
Cross Talk Ratio	CTK	-	-	-	3.5	%	Note 14-7

Note 14-1: Topcon BM-5A or BM-7 fast luminance meter 1° field of view is used in the testing.

Note 14-2: The definitions of viewing angles are as follow

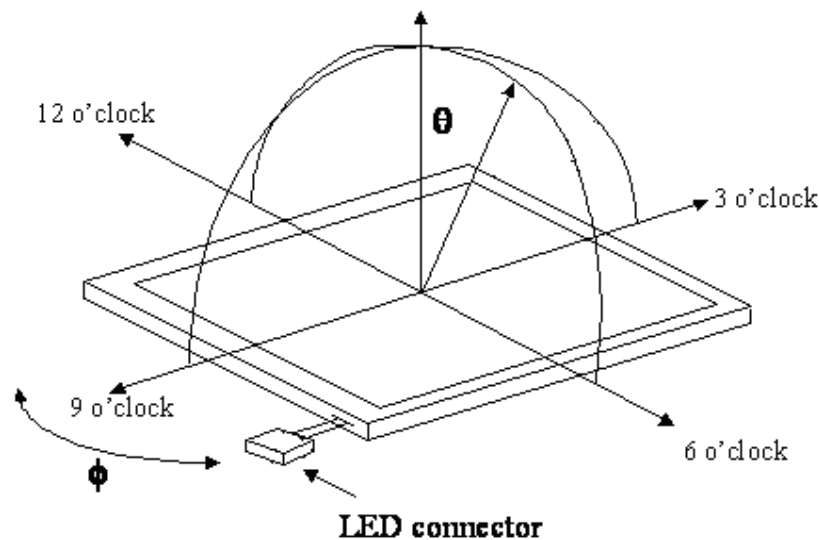

Note 14-3: The definition of contrast ratio: $CR = \frac{\text{Luminance at White Pattern}}{\text{Luminance at Black Pattern}}$

Note 14-4: The "LED Life time " is defined as the module brightness decrease to 50% original Brightness that the ambient temperature is 25°C and $I_{LED} = 360\text{mA}$.

Note 14-5: Definition of Response Time T_r and T_f

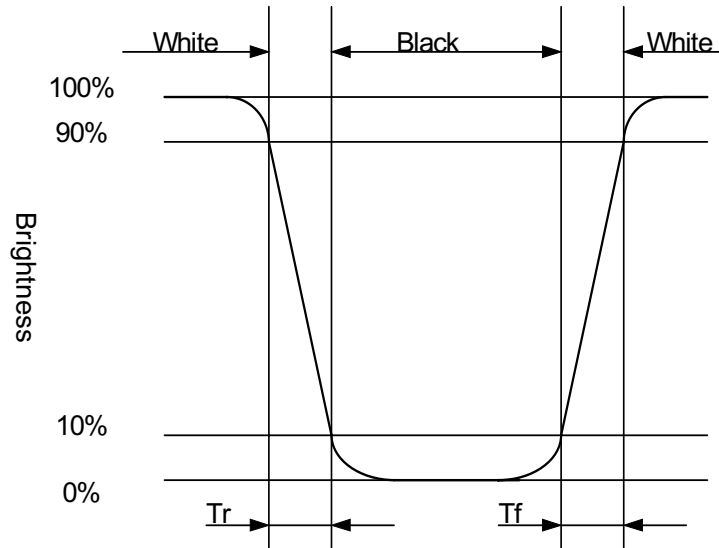

Note 14-6: The uniformity of LCD is defined as

$$U = \frac{\text{The Minimum Brightness of the 9 testing Points}}{\text{The Maximum Brightness of the 9 testing Points}}$$

Luminance meter: BM-5A or BM-7 fast (TOPCON)

Measurement distance: 500 mm +/- 50 mm

Ambient illumination: < 1 Lux

Measuring direction: Perpendicular to the surface of module

The test pattern is white (Gray Level 63).

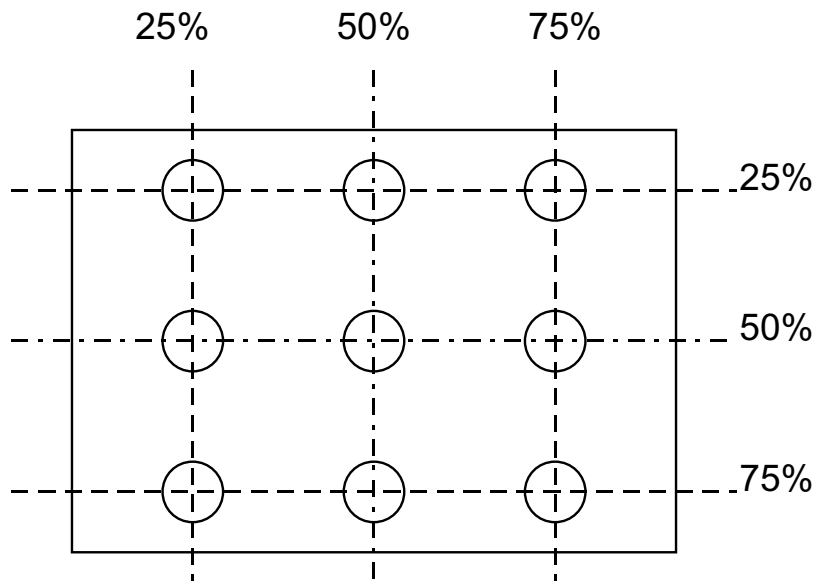

Note 14-7: Cross Talk (CTK) = $\frac{|YA-YB|}{YA} \times 100\%$

YA: Brightness of Pattern A
 YB: Brightness of Pattern B
 Luminance meter: BM 5A (TOPCON)
 Measurement distance: 500 mm +/- 50 mm
 Ambient illumination: < 1 Lux
 Measuring direction: Perpendicular to the surface of module

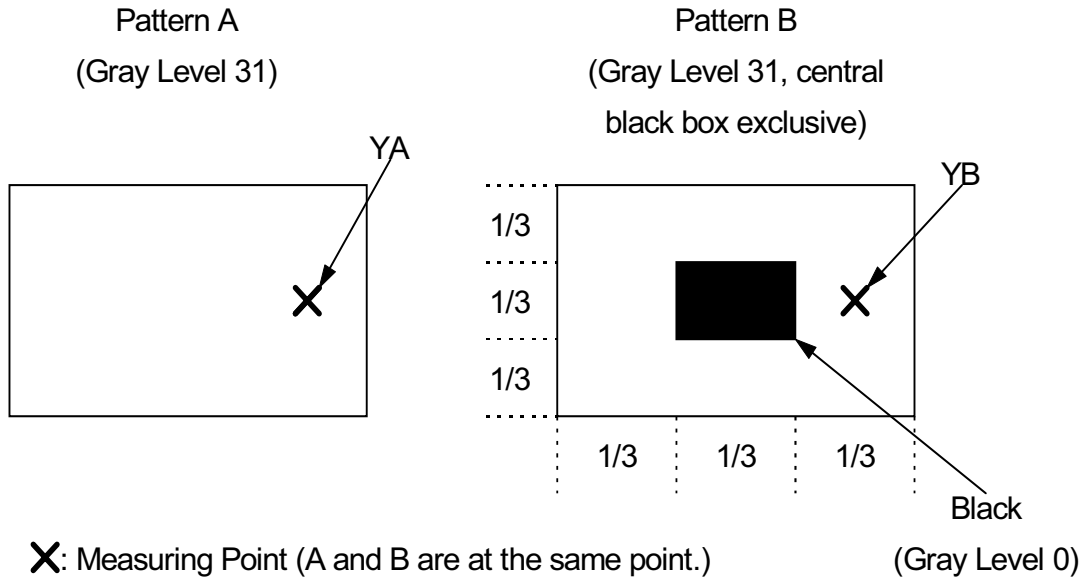

15. Handling Cautions
15-1) Mounting of module

- a) Please power off the module when you connect the input/output connector.
- b) Polarizer which is made of soft material and susceptible to flaw must be handled carefully.
- c) Protective film (Laminator) is applied on surface to protect it against scratches and dirt.
- d) Please following the tear off direction as figure 15-1 to remove the protective film as slowly as possible, so that electrostatic charge can be minimized.

15-2) Precautions in mounting

- a) When metal part of the TFT-LCD module (shielding lid and rear case) is soiled, wipe it with soft dry cloth.
- b) Wipe off water drops or finger grease immediately. Long contact with water may cause discoloration or spots.
- c) TFT-LCD module uses glass which breaks or cracks easily if dropped or bumped on hard surface. Please handle with care.
- d) Since CMOS LSI is used in the module. So take care of static electricity and earth yourself when handling.

15-3) Adjusting module

- a) Adjusting volumes on the rear face of the module have been set optimally before shipment.
- b) Therefore, do not change any adjusted values. If adjusted values are changed, the specifications described may not be satisfied.

15-4) Others

- a) Do not expose the module to direct sunlight or intensive ultraviolet rays for many hours.
- b) Store the module at a room temperature place.
- c) The voltage of beginning electric discharge may over the normal voltage because of leakage current from approach conductor by to draw lump read lead line around.
- d) If LCD panel breaks, it is possibly that the liquid crystal escapes from the panel. Avoid putting it into eyes or mouth. When liquid crystal sticks on hands, clothes or feet. Wash it out immediately with soap.
- e) Observe all other precautionary requirements in handling general electronic components.
- f) Please adjust the voltage of common electrode as material of attachment by 1 module.

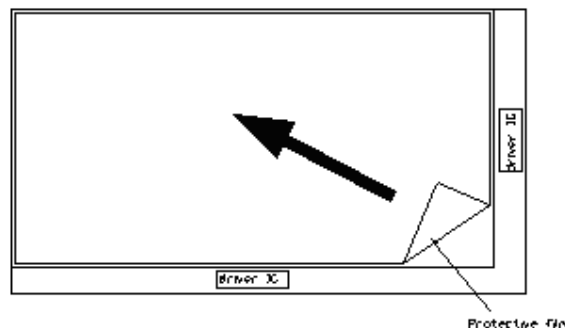

Figure 15-1 the way to peel off protective film

16. Reliability Test

No	Test Item	Test Condition
1	High Temperature Storage Test	Ta = +80°C, 240 hrs
2	Low Temperature Storage Test	Ta = -40°C, 240 hrs
3	High Temperature Operation Test	Ta = +70°C, 240 hrs
4	Low Temperature Operation Test	Ta = -10°C, 240 hrs
5	High Temperature & High Humidity Operation Test	Ta = 60°C, 90%RH, 240 hrs
6	Thermal Cycling Test (non-operating)	-40°C(1hour) →+80°C(1hour), 100Cycles
7	Vibration Test (non-operating)	Frequency : 10 ~ 57 Hz, Amplitude : 0.15 mm,58~500Hz, 1G Sweep time: 11 min Test Period: 3 hrs (1 hr for each direction of X, Y, Z)
8	Shock Test (non-operating)	80G, 6ms, X,Y, Z 1 times for each direction
9	Electrostatic Discharge Test (Operation)	C=150pF,R=330Ω Contact=±8KV Air=±15KV 10 times/terminal

Ta: ambient temperature

Note: The protective film must be removed before temperature test.

[Criteria]

In the standard conditions, there is not display function NG issue occurred. (including : line defect ,no image). All the cosmetic specification is judged before the reliability stress.

17. Packing Diagram

ZONE	REV.	DOCUMENT NO.	DESCRIPTION	DATE	REV.BY
<p>NOTE: 1.Q'TY: 15 pcs moudule /carton. 2.Dimension: 465*362*314mm 3.Weight: 16 Kg</p>					
4	50-0100291	CARTON		1	
3	50-0500391	抗靜電摺口袋		15	抗靜電
2	PD121XL6	12.1"XGA T/P Module		15	
1	50-0302471	瓦楞隔板緩衝材		1	上蓋+底座
ITEM	PART NO.	DESCRIPTION		QTY	REMARK
MTL.SPEC.		UNSPECIFIED TOL'S		REMARK	
		ANGLE			
		ROUGHNESS			
APPROVE	Patrick Lin	'09.12.25	SCALE	UNIT	SHEET
CHECK	Patrick Lin	'09.12.25			1 OF 1
DRAWN	Ethan Chen	'09.12.25	MTL.NO.		DWG FILE:
				RBV.	A4 SIZE
				02	

元太科技工業股份有限公司
Prime View International Co., Ltd.