

AP.10E.07.0039B

Specification

Part No.	AP.10E.07.0039B
Product Name	AP.10E - 1 Stage 15dB 39mm 0.81 with IPEX MHFI (U.FL compatible)
Feature	World smallest GPS active patch High performance Ultra low power consumption RoHS Compliant

1. Introduction

AP.10E active GPS patch antenna is the smallest GPS high performance antenna currently available in the world. Using extremely sensitive high dielectric constant powder formulation and tight process control the 10*10*4mm patch antenna is accurately tuned to have its frequency band

right at 1575.42MHz for GPS systems. With an ultra low power consumption one stage LNA , this small active patch has the performance of an ordinary active patch, but at only a quarter of the size. This product is suited to small form factor mobile devices such as GPS Smartphones, Personal Loca-

tion, Medical devices, Telematic devices and Automotive navigation and tracking. Custom gain, connector and cable versions are available. The AP.10E consists of 2 functional blocks – the LNA and also the patch antenna.

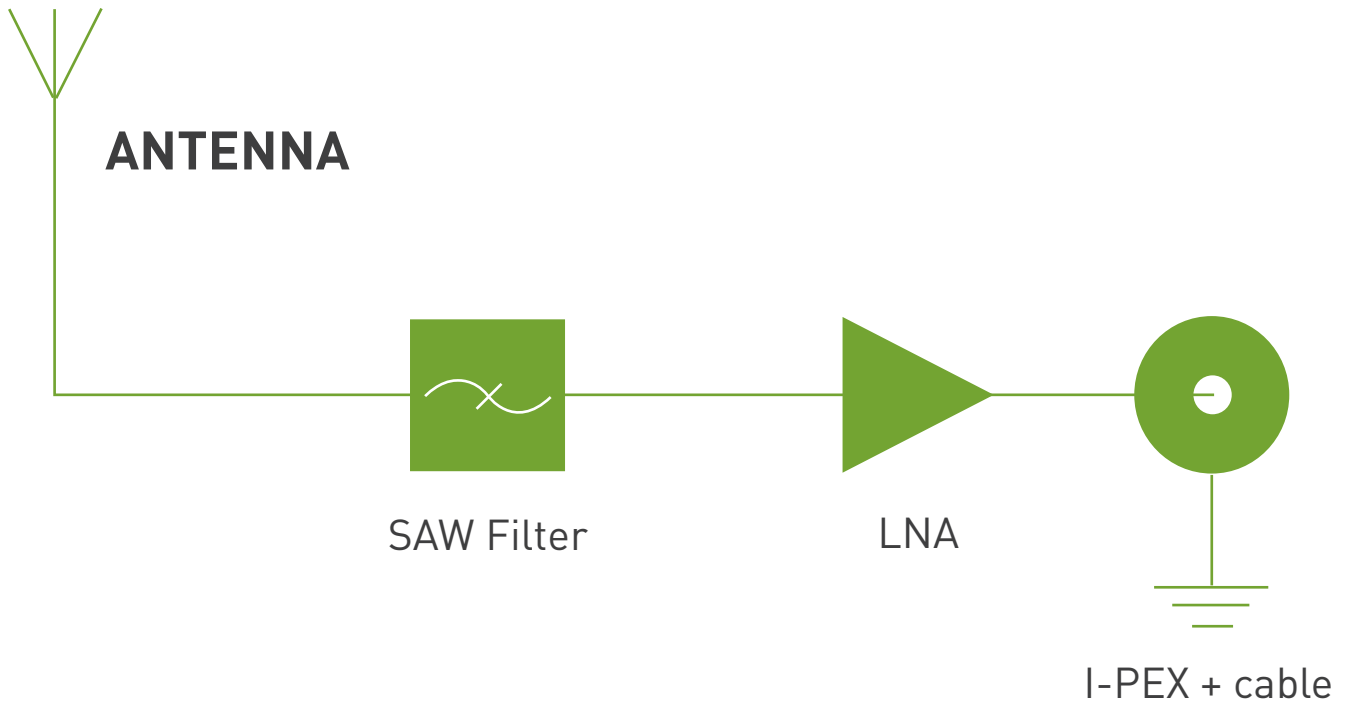

2. Specification

2.1 Patch Antenna

Parameter	Specification
Frequency	1575.42 ± 1.023MHz
Gain @ Zenith	-10dBic Typ. @ Zenith
Polarization	RHCP
Axial Ratio	4.0dB max @ Zenith
Patch Dimension	10*10*4.0mm

2.2 LNA

Parameter	Specification
Frequency	1575.42 ± 1.023MHz
Outer Band Attenuation	F0=1575.42MHz F0±30MHz 9dB min. F0±50MHz 20dB min. F0±100MHz 25dB min.
Output Impedance	50Ω
Output VSWR	2.0 Max
Pout at 1dB Gain	Typ. -2dBm
Compression point	Min. -6dBm

LNA Gain, Power Consumption and Noise Figure

Voltage	LNA Gain (Typ)	Power Consumption(mA) Typ	Noise Figure Typ
Min. 1.8V	14dB	3mA	2.5dB
Typ. 3.0V	15dB	3mA	2.5dB
Max. 5.5V	15dB	3mA	2.6dB

2.3 Cable* & Connector

Parameter	Specification
RF Cable	Coaxial Cable Ø 0.81 ± 0.1mm, length 39 ± 2.0mm
Connector	IPEX MHFI (U.FL)

3. LNA Gain and Out Band Rejection @3.0V

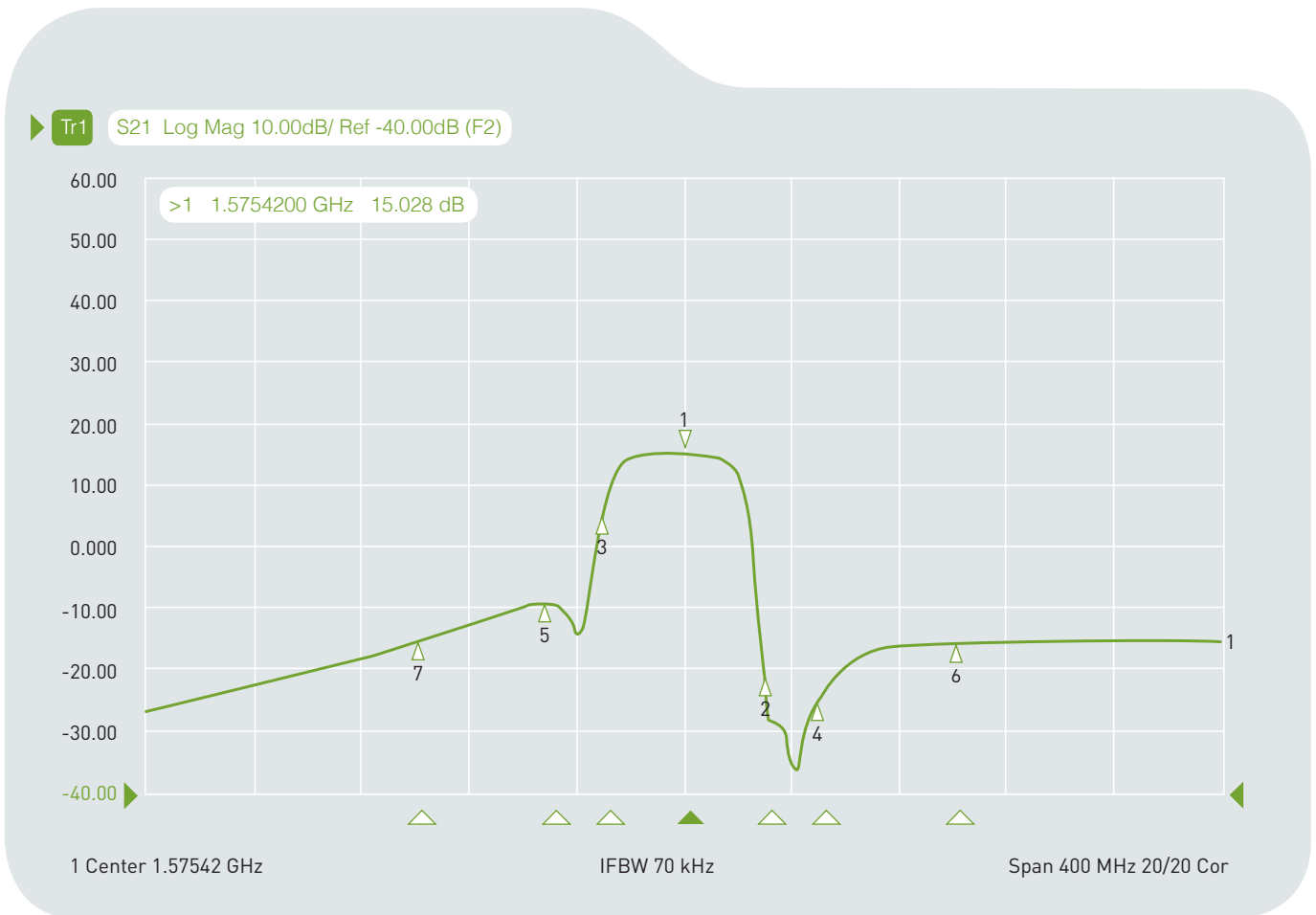

Cg1	Tr1	S21	>1	1.5754200 GHz	15.028	dB
Cg1	Tr1	S21	2	1.6054200 GHz	-20.790	dB
Cg1	Tr1	S21	3	1.5454200 GHz	5.4162	dB
Cg1	Tr1	S21	4	1.6254200 GHz	-24.871	dB
Cg1	Tr1	S21	5	1.5254200 GHz	-9.3837	dB
Cg1	Tr1	S21	6	1.6754200 GHz	-15.459	dB
Cg1	Tr1	S21	7	1.4754200 GHz	-15.752	dB

4. LNA Noise Figure @3.0V

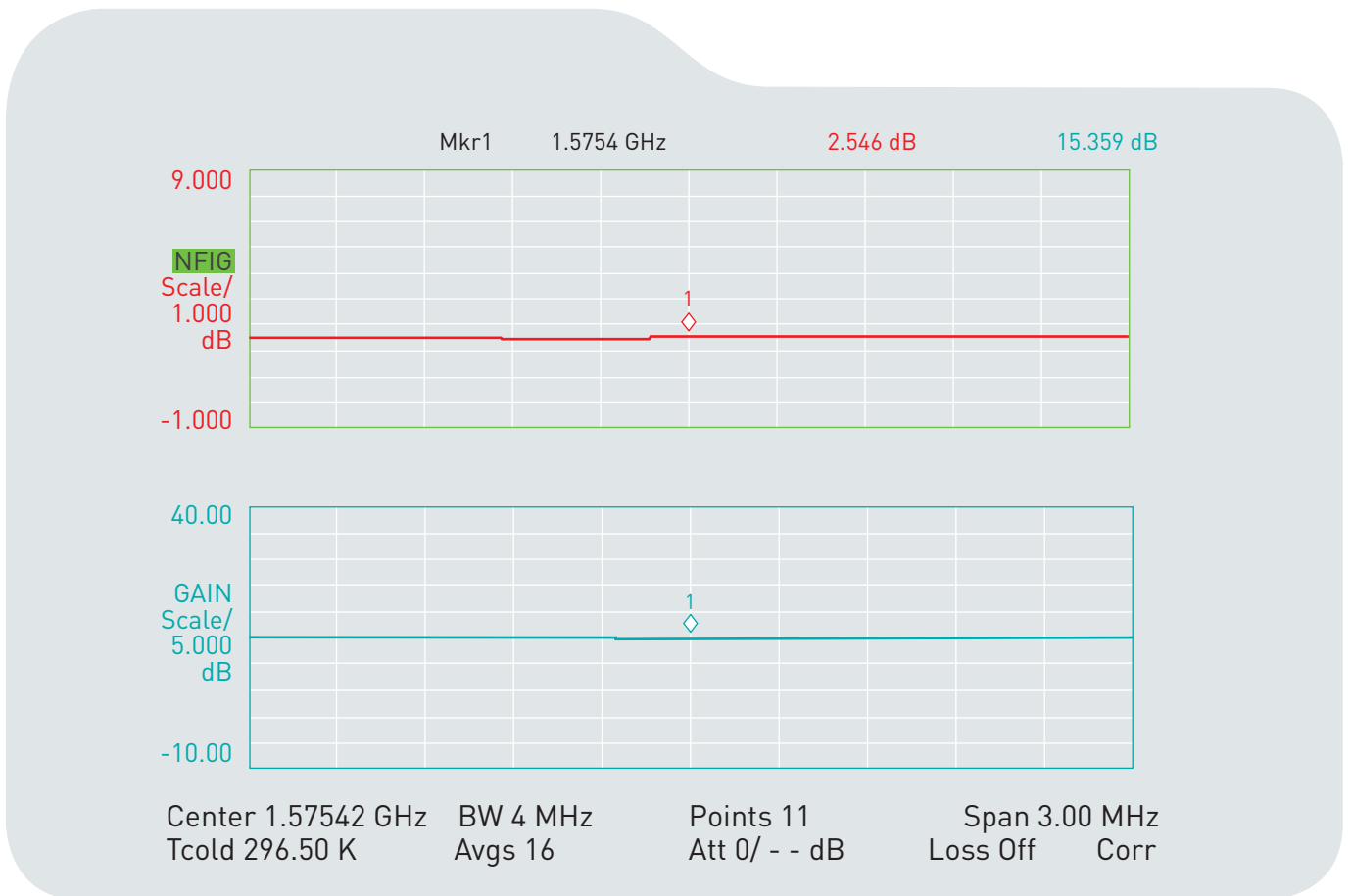

5. Total Specification (through Antenna, LNA, Cable and Connector)

Parameter	Specification
Frequency	1575.42 ± 1.023MHz
Gain	At 3V: 5 ± 4dBic @ 90°
Output Impedance	50Ω
Polarization	RHCP
Output VSWR	Max 2.0
Operation Temperature	-40°C to + 85°C
Storage Temperature	-40°C to + 85°C
Relative Humidity	40% to 95%
Input Voltage	Min. 1.8V, Typ. 3.0V, Max. 5.5V
Antenna	10*10*5.9mm

6. Radiation Patterns

6.1 XZ Plane Radiation

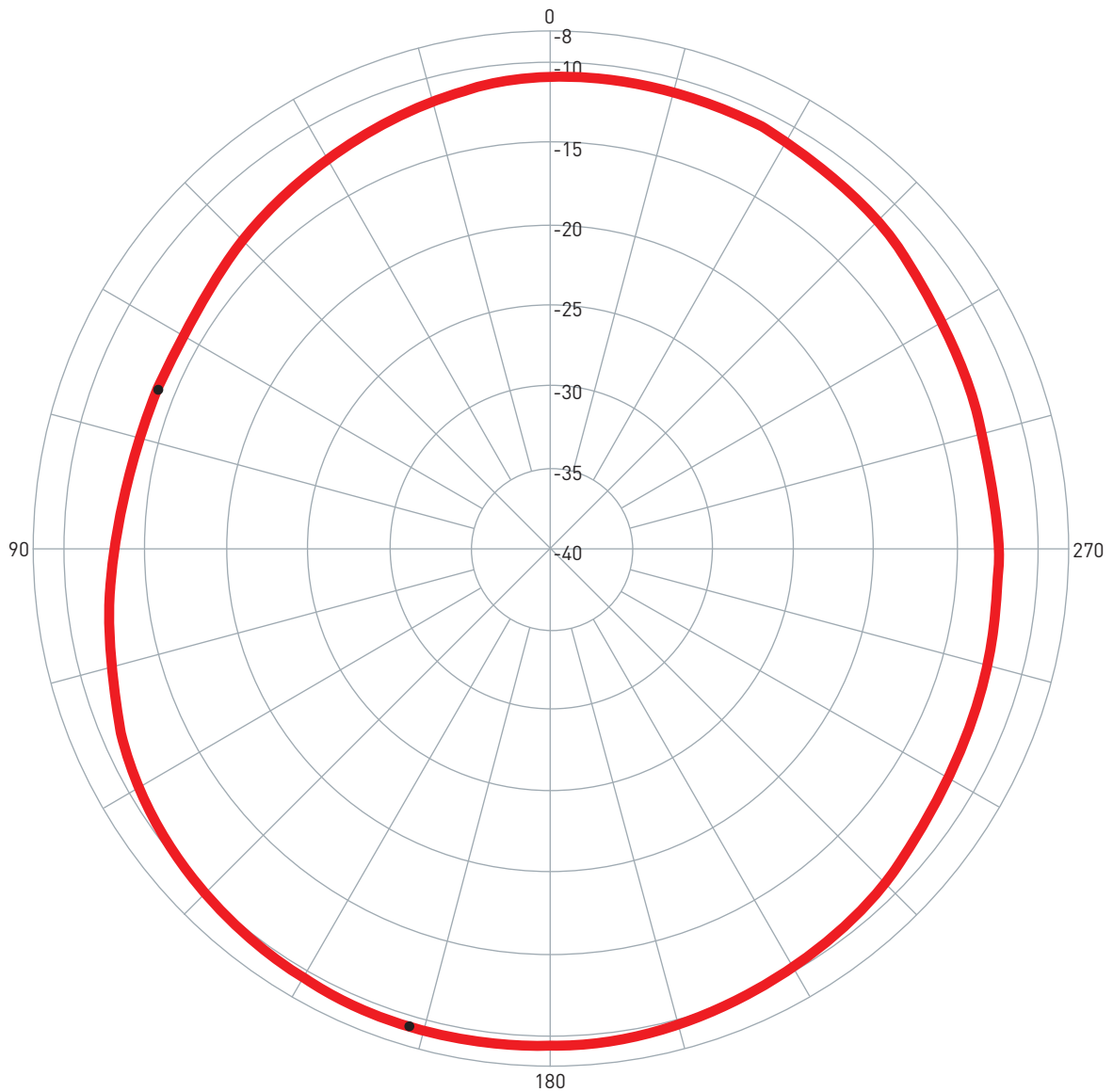

Pattern	Model No.	Test Mode	Freq (MHz)	Max Gain(dBi)	Min Gain(dBi)	Avg. Gain(dBi)	Source Polar.
1 	AP.10E.07.0039B	XZ	1624.00	-9.27 / 163.26	-13.80 / 68.02	-11.23	RHCP

6.2 YZ Plane Radiation

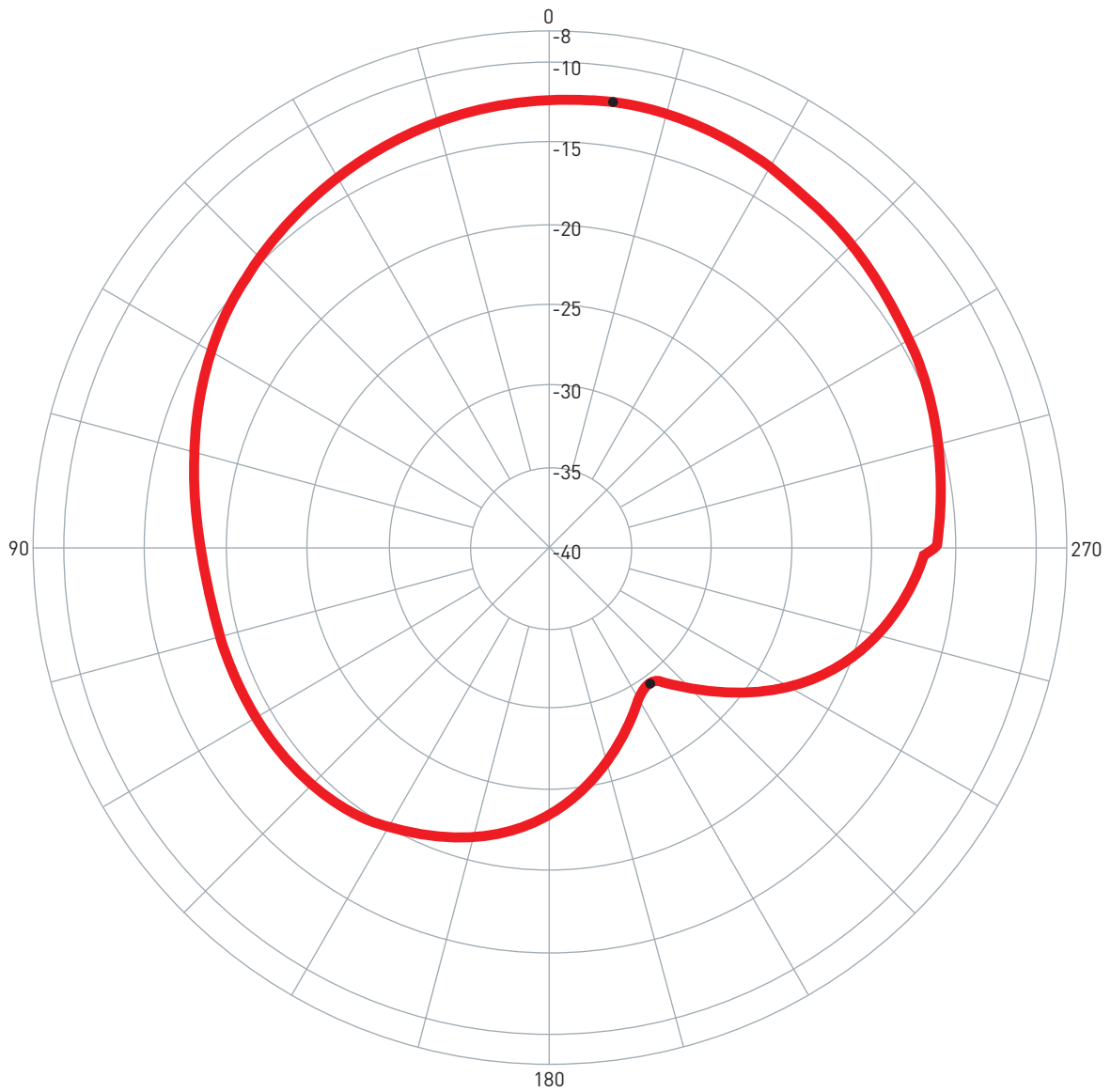

Pattern	Model No.	Test Mode	Freq (MHz)	Max Gain(dBi)	Min Gain(dBi)	Avg. Gain(dBi)	Source Polar.
1 	AP.10E.07.0039B	YZ	1624.00	-12.30 / 352.00	-29.55 / 216.00	-16.23	RHCP

6.3 XY Plane Radiation

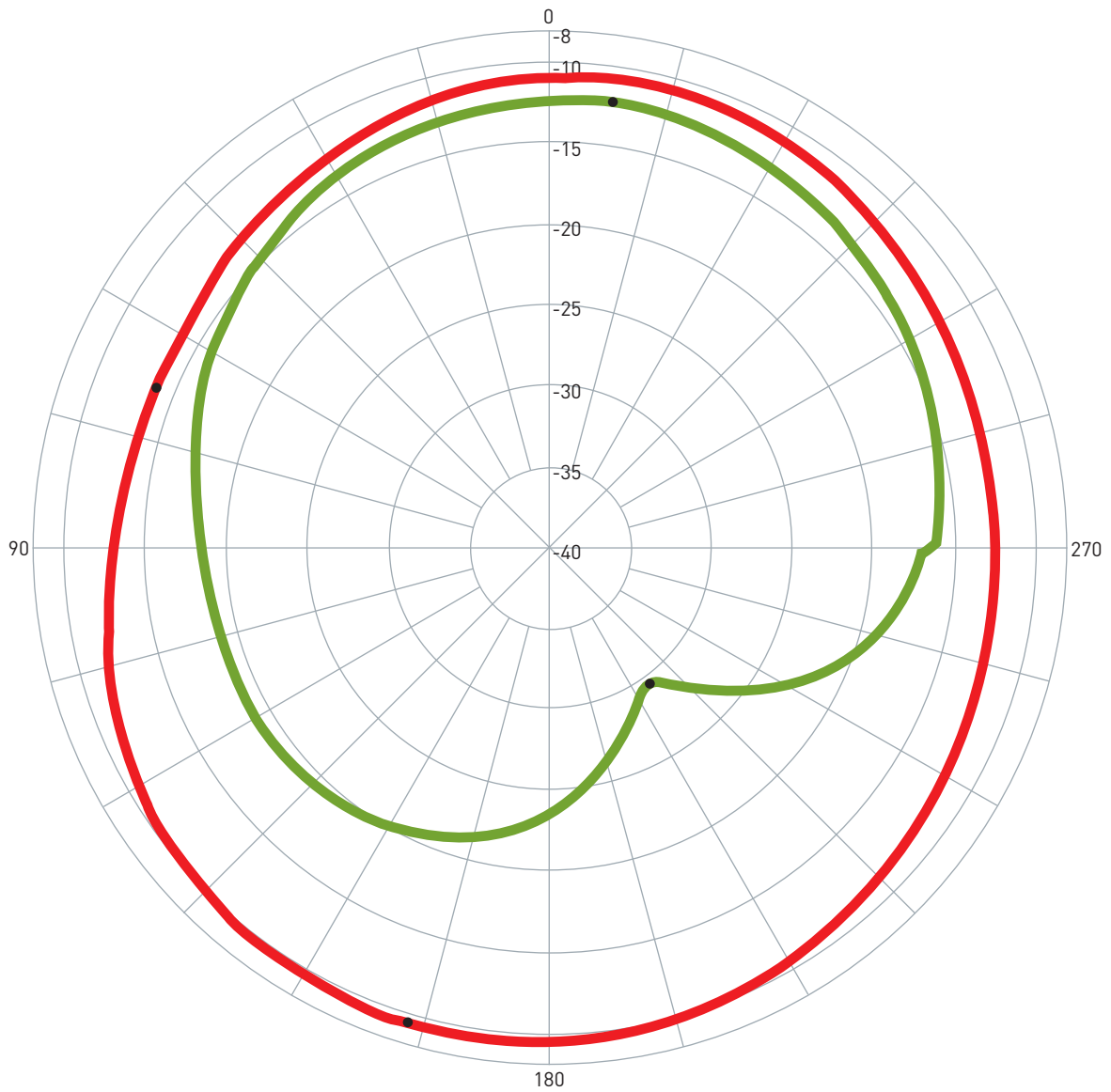

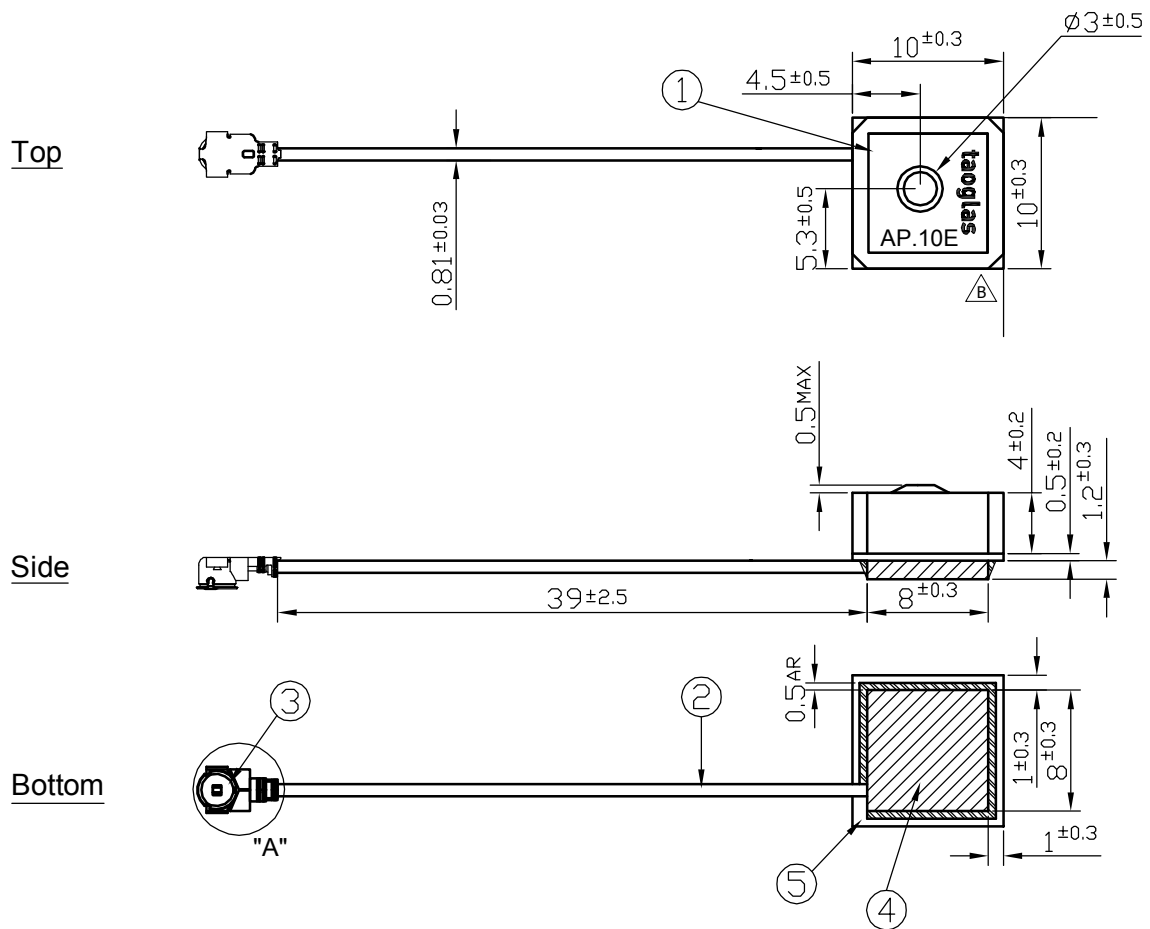

Pattern	Model No.	Test Mode	Freq (MHz)	Max Gain(dBi)	Min Gain(dBi)	Avg. Gain(dBi)	Source Polar.
1	AP.10E.07.0039B	XZ	1624.00	-9.27 / 163.26	-13.80 / 68.02	-11.23	RHCP
2	AP.10E.07.0039B	YZ	1624.00	-12.30 / 352.00	-29.55 / 216.00	-16.23	RHCP

7. Technical Drawing



NOTE:

1. Soldered area 
2. Shielding case area 
3. All material must be RoHS compliant.
4. The connector orientation has a fixed position to the antenna as per drawing.

	Name	P/N	Material	Finish	QTY
1	AP.10E Patch (10*10*4mm)	AP.10E	Ceramic	Clear	1
2	0.81 Coaxial Cable	OD.081.CM	FEP	Gray	1
3	IPEX MHF1	IPEX.MHFI.113	Brass	Gold	1
4	Shielding Case		Tin (SPTE)	Tin Plated	1
5	PCB		FR4 0.5t	Green	1

7.1 Connector Drawing

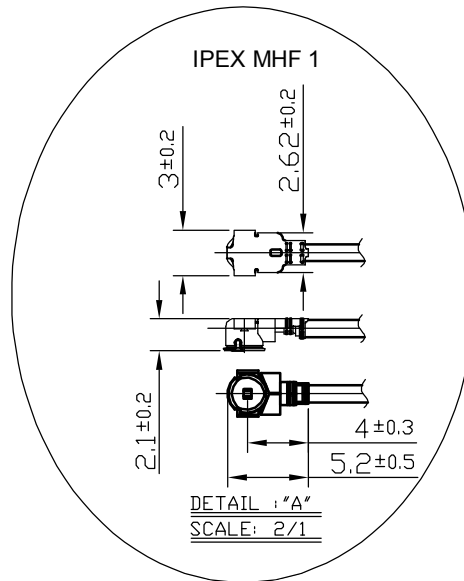

8. Plugs Usage Precautions

8.1 Mating / unmating

(1) To disconnect connectors, insert the end portion of I-PEX under the connector flanges and pull off vertically, in the direction of the connector mating axis.

(2) To mate the connectors, the mating axes of both connectors must be aligned and the connectors can be mated. The "click" will confirm fully mated connection.

Do not attempt to insert on an extreme angle.

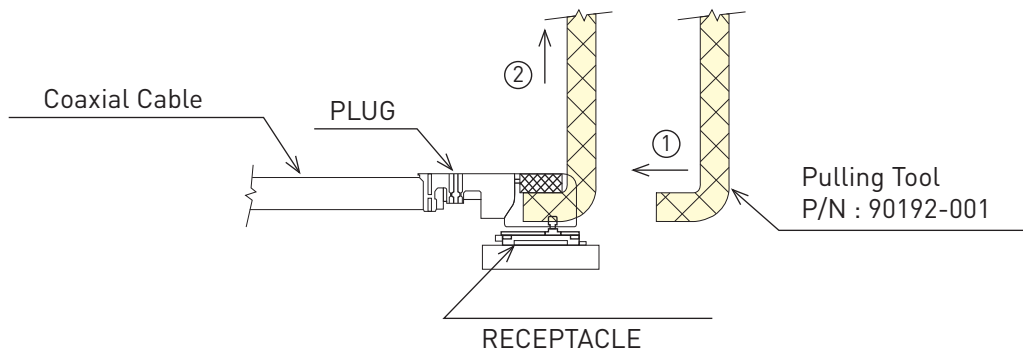

8.2 Pull forces on the cable after connectors are mated

After the connectors are mated, do not apply a load to the cable in excess of the values indicated in the diagram below.

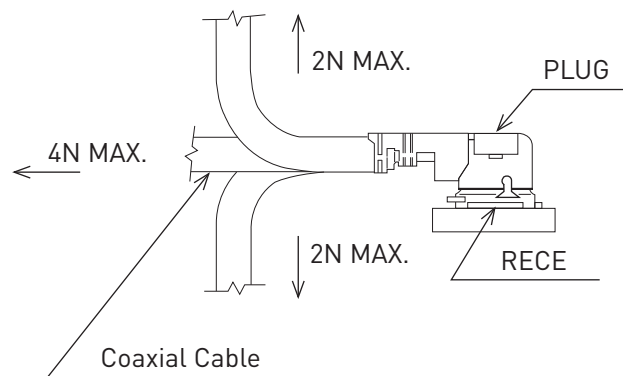

9. Packaging

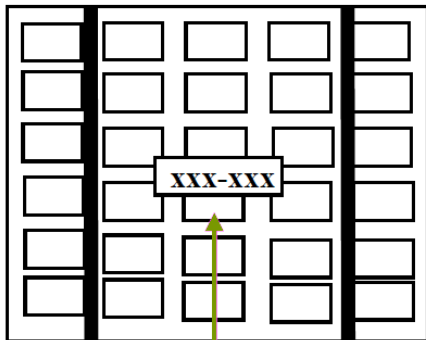

- *Packaged in Tray with Foam
- *One Tray = 60 pieces
- *6 Trays per Section = 360 pcs

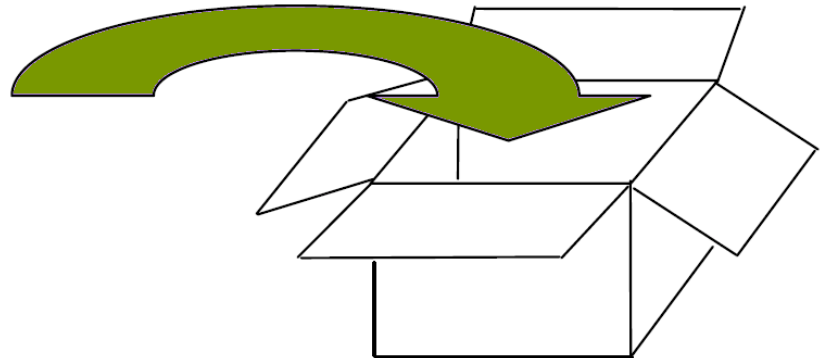

- *Each Carton contains 3 Sections
- *1080 pieces per Carton

Taoglas makes no warranties based on the accuracy or completeness of the contents of this document and reserves the right to make changes to specifications and

product descriptions at any time without notice.

Taoglas reserves all rights to this document and the information

contained herein. Reproduction, use or disclosure to third parties without express permission is strictly prohibited. Copyright © Taoglas Ltd.