

## 400mA Low Dropout Linear Regulator

### ❖ GENERAL DESCRIPTION

AX1006 is a low dropout positive adjustable or fixed-mode regulator with minimum of 400mA output current capability. The product is specifically designed to provide well-regulated supply for low voltage IC applications such as high-speed bus termination and low current 3.3V logic supply. AX1006 is also well suited for other applications such as VGA cards. AX1006 is guaranteed to have lower than 1.2V dropout at full load current making it ideal to provide well-regulated outputs of 1.25 to 5.0 with  $V_{OUT}+1.2V$  to 12V input supply VOLTAGE.

### ❖ FEATURES

- 1.2V maximum dropout at full load current
- Fast transient response
- Output current limiting
- Built-in thermal shutdown
- Good noise rejection
- MLCC Capacitors are available.
- 3-Terminal Adjustable or Fixed 1.2V, 1.5V, 1.8V, 2.5V, 3.3V, 5.0V
- Package: SOT-23-3L.

### ❖ APPLICATION CIRCUIT

**Fixed Output**

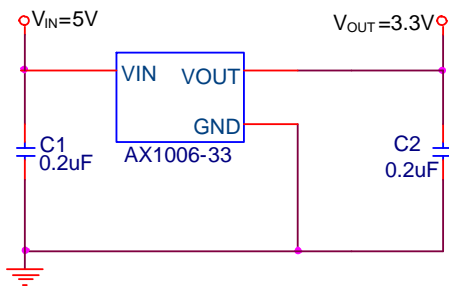

**ADJ Output**

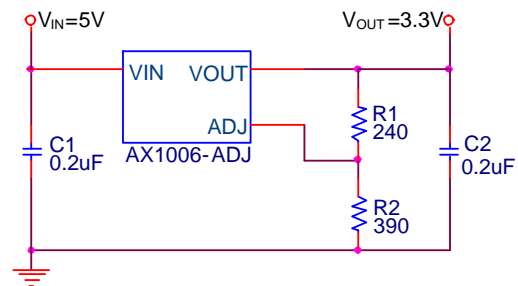

$$V_{OUT} = V_{REF} \times \left(1 + \frac{R2}{R1}\right); V_{REF} = 1.250V$$

❖ **PIN ASSIGNMENT**

The package of AX1006 is SOT-23-3L; the pin assignment is given by:

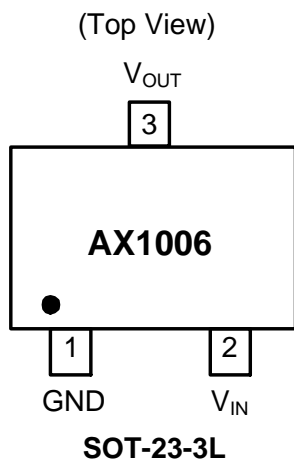

Name	Description
<b>Adj (GND)</b>	A resistor divider from this pin to the V <sub>OUT</sub> pin and ground sets the output voltage. (Ground only for Fixed-Mode)
<b>V<sub>OUT</sub></b>	The output of the regulator. <b>(Note1,2)</b>
<b>V<sub>IN</sub></b>	The input pin of regulator. Typically a large storage capacitor is connected from this pin to ground to insure that the input voltage does not sag below the minimum dropout voltage during the load transient response. This pin must always be 1.5V higher than V <sub>OUT</sub> in order for the device to regulate properly. <b>(Note1)</b>

Note1: To prevent oscillation, a 0.2uF minimum X7R or X5R dielectric is strongly recommended if ceramics are used as output capacitors.

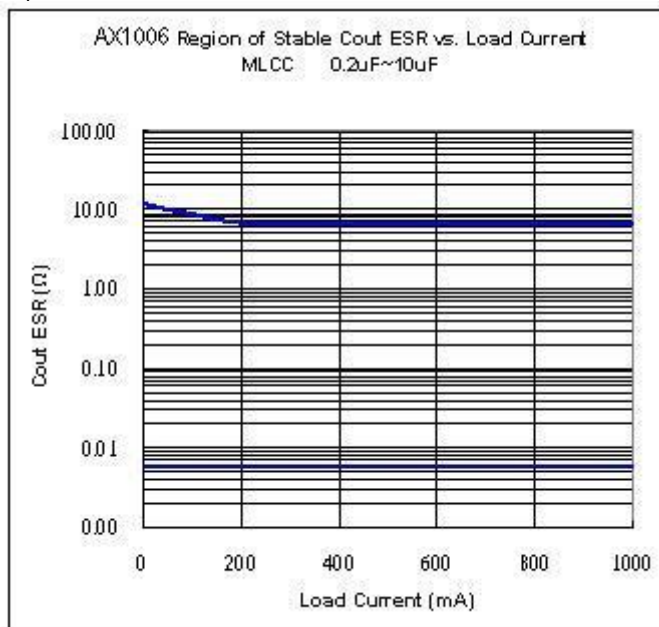

Note2: A minimum of 3.3uF EL capacitor to 100uF (10mΩ ≤ ESR ≤ 1Ω) must be connected from this pin to ground to insure stability.



### ❖ ELECTRICAL CHARACTERISTICS

( $T_A=25^{\circ}\text{C}$ , Under Operating Conditions)

Characteristics	Conditions		Min	Typ	Max	Units
Operation Input Voltage			2.7	-	12	V
Reference Voltage	AX1006-ADJ	$I_{OUT} = 10\text{mA}$ , $T_J=25^{\circ}\text{C}$ , $(V_{IN-OUT})=1.5\text{V}$	1.225	1.250	1.275	V
Output Voltage	AX1006-1.2	$I_{OUT}=10\text{mA}$ , $T_J = 25^{\circ}\text{C}$ , $2.7\text{V} \leq V_{IN} \leq 12\text{V}$	1.176	1.200	1.224	V
	AX1006-1.5	$I_{OUT} = 10\text{mA}$ , $T_J = 25^{\circ}\text{C}$ , $3\text{V} \leq V_{IN} \leq 12\text{V}$	1.470	1.500	1.530	V
	AX1006-1.8	$I_{OUT} = 10\text{mA}$ , $T_J = 25^{\circ}\text{C}$ , $3.3\text{V} \leq V_{IN} \leq 12\text{V}$	1.764	1.800	1.836	V
	AX1006-2.5	$I_{OUT} = 10\text{mA}$ , $T_J = 25^{\circ}\text{C}$ , $4\text{V} \leq V_{IN} \leq 12\text{V}$	2.450	2.500	2.550	V
	AX1006-3.3	$I_{OUT} = 10\text{mA}$ , $T_J = 25^{\circ}\text{C}$ , $4.8\text{V} \leq V_{IN} \leq 12\text{V}$	3.235	3.300	3.365	V
	AX1006-5.0	$I_{OUT} = 10\text{mA}$ , $T_J = 25^{\circ}\text{C}$ , $6.5\text{V} \leq V_{IN} \leq 12\text{V}$	4.900	5.000	5.100	V
Line Regulation	AX1006-XXX	$I_{OUT} = 10\text{mA}$ , $V_{OUT}+1.5\text{V} < V_{IN} < 12\text{V}$ , $T_J=25^{\circ}\text{C}$ (Note 1,2)	-	0.2	0.5	%
Load Regulation	AX1006-ADJ	$V_{IN}=2.7\text{V}$ , $10\text{mA} \leq I_{OUT} \leq 400\text{mA}$ , $T_J=25^{\circ}\text{C}$ (Note 1,2)	-	0.4	1	%
	AX1006-1.2	$V_{IN}=2.7\text{V}$ , $10\text{mA} \leq I_{OUT} \leq 400\text{mA}$ , $T_J=25^{\circ}\text{C}$ (Note 1,2)	-	10	12	mV
	AX1006-1.5	$V_{IN}=3\text{V}$ , $10\text{mA} \leq I_{OUT} \leq 400\text{mA}$ , $T_J=25^{\circ}\text{C}$ (Note 1,2)	-	12	15	mV
	AX1006-1.8	$V_{IN}=3.3\text{V}$ , $10\text{mA} \leq I_{OUT} \leq 400\text{mA}$ , $T_J=25^{\circ}\text{C}$ (Note 1,2)	-	15	18	mV
	AX1006-2.5	$V_{IN}=4\text{V}$ , $10\text{mA} \leq I_{OUT} \leq 400\text{mA}$ , $T_J=25^{\circ}\text{C}$ (Note 1,2)	-	20	25	mV
	AX1006-3.3	$V_{IN}=5\text{V}$ , $10\text{mA} \leq I_{OUT} \leq 400\text{mA}$ , $T_J=25^{\circ}\text{C}$ (Note 1,2)	-	26	33	mV
	AX1006-5.0	$V_{IN}=6.5\text{V}$ , $10\text{mA} \leq I_{OUT} \leq 400\text{mA}$ , $T_J=25^{\circ}\text{C}$ (Note 1,2)	-	40	50	mV
Dropout Voltage ( $V_{IN}-V_{OUT}$ )	AX1006-ADJ /1.2/1.5/1.8 /2.5/3.3/5.0	$I_{OUT} = 400\text{mA}$ , $\Delta V_{OUT}=1\%V_{OUT}$	-	1.0	1.2	V

❖ **ELECTRICAL CHARACTERISTICS (CONTINUED)**

Current Limit	AX1006-ADJ/ 1.5/1.8/2.5/3.3/5.0	$(V_{IN}-V_{OUT}) = 1.5V$	450	-	-	mA
Minimum Load Current	AX1006-XXX	$0^{\circ}C \leq T_j \leq 125^{\circ}C$	-	5	10	mA
Adjust pin current	AX1006-ADJ	$(V_{IN}-V_{OUT}) = 1.5V,$ $I_{OUT}=10mA$	-	50	100	uA
Ripple Rejection	F=120Hz, $C_{OUT}=10\mu F$ AX1006-XX, $(V_{IN}-V_{OUT}) = 1.5V$		-	60	70	dB
Temperature Stability	$I_{OUT}=10mA$		-	0.5	-	%

Note1: See thermal regulation specifications for changes in output voltage due to heating effects. Line and load regulation are measured at a constant junction temperature by low duty cycle pulse testing. Load regulation is measured at the output lead = 1/18" from the package.

Note2: Line and load regulation are guaranteed up to the maximum power dissipation of 5W. Power dissipation is determined by the difference between input and output differential and the output current. Guaranteed maximum power dissipation will not be available over the full input/output range.

Note3: Quiescent current is defined as the minimum output current required in maintaining regulation. At 12V input/output differential the device is guaranteed to regulate if the output current is greater than 10mA.

❖ TYPICAL CHARACTERISTICS

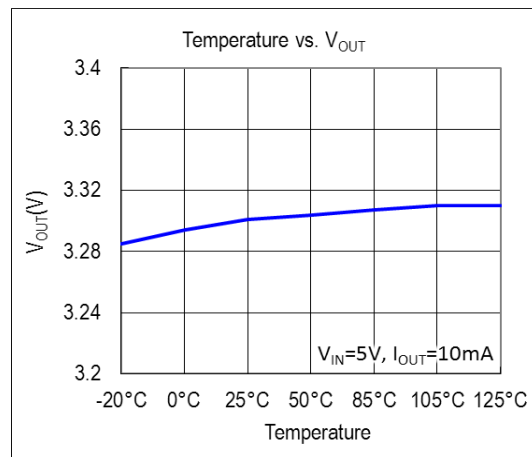
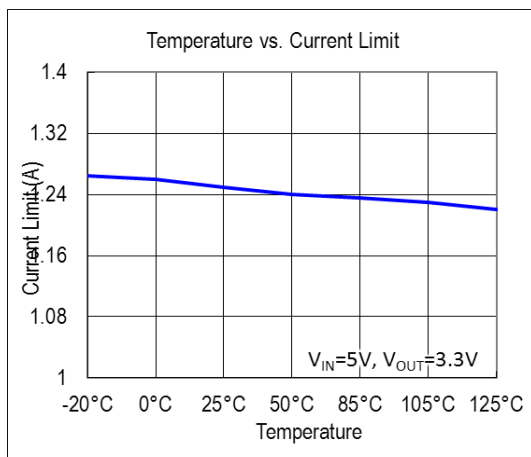
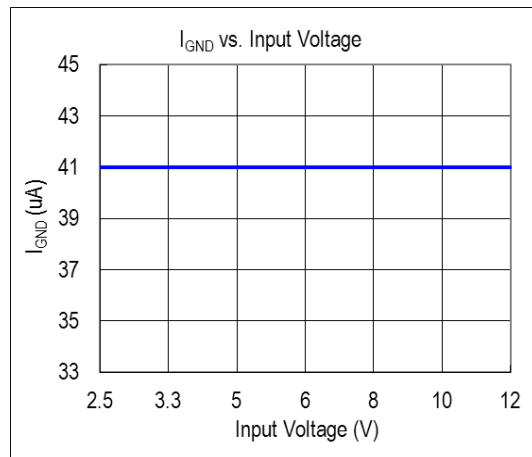
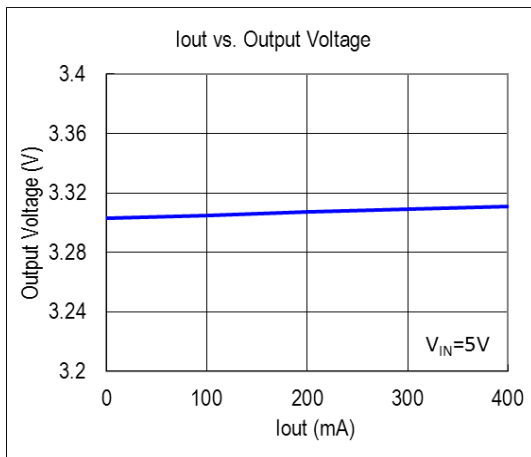
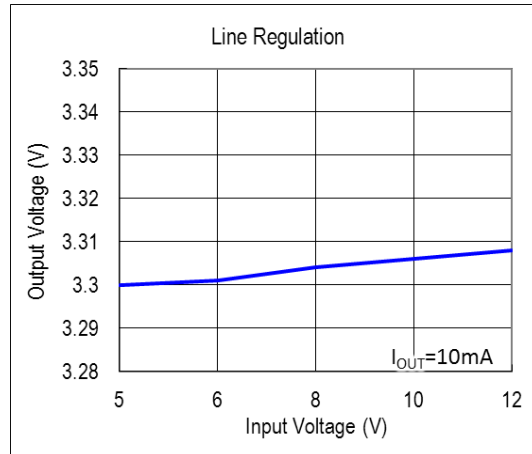
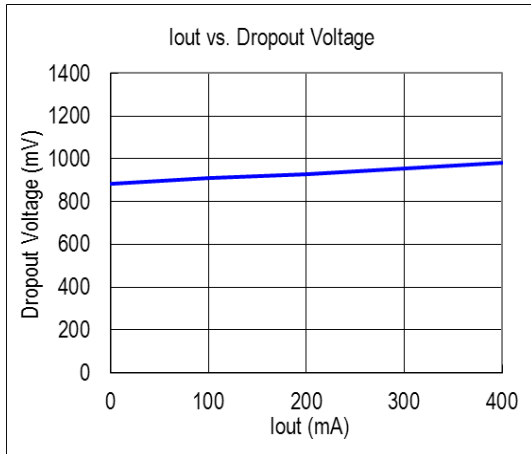

❖ TYPICAL CHARACTERISTICS (CONTINUED)

5→3.3V (I<sub>OUT</sub>=100mA)

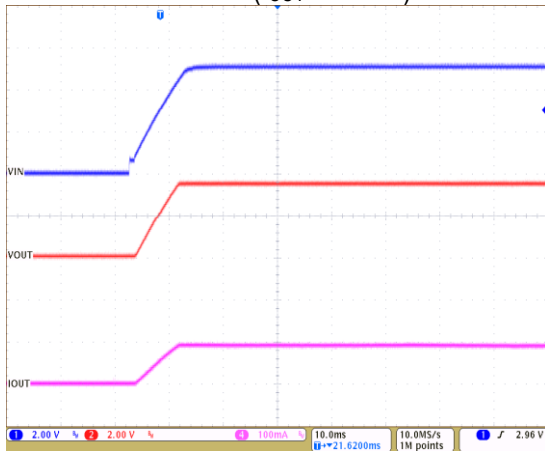

5→3.3V (I<sub>OUT</sub>=100mA)

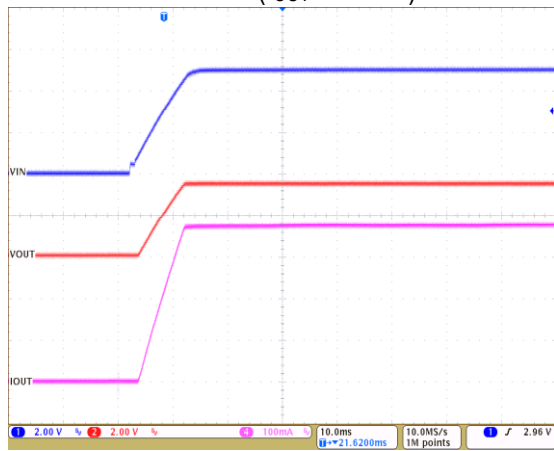

V<sub>IN</sub>=5V, V<sub>OUT</sub>=3.3V,  
I<sub>OUT</sub>=0mA~400mA,  
C<sub>IN</sub>=0.1u, C<sub>OUT</sub>=0.2u MLCC

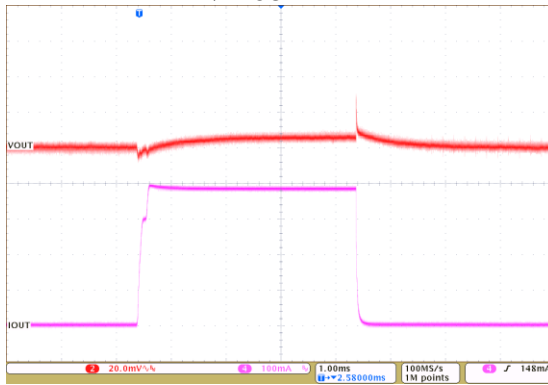

V<sub>IN</sub>=5V, V<sub>OUT</sub>=3.3V,  
I<sub>OUT</sub>=100mA~400mA,  
C<sub>IN</sub>=0.1u, C<sub>OUT</sub>=0.2u MLCC

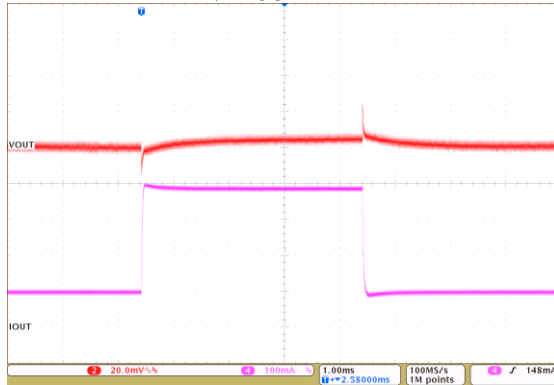

❖ PACKAGE OUTLINES

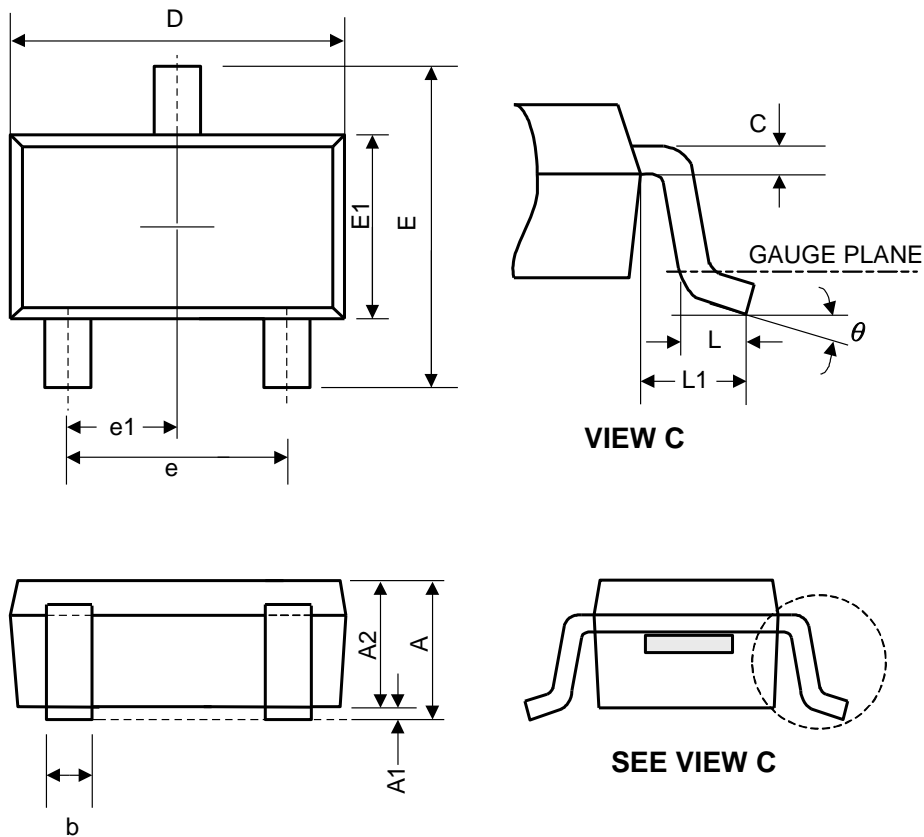

Symbol	Dimensions in Millimeters			Dimensions in Inches		
	Min.	Nom.	Max.	Min.	Nom.	Max.
A	-	-	1.45	-	-	0.057
A1	0.00	0.08	0.15	-	-	0.006
A2	0.90	1.10	1.30	0.035	0.043	0.051
b	0.30	0.40	0.50	0.012	0.016	0.020
C	0.08	0.15	0.22	0.003	0.006	0.009
D	2.70	2.90	3.10	0.106	0.114	0.122
E	2.60	2.80	3.00	0.102	0.110	0.118
E1	1.40	1.60	1.80	0.055	0.063	0.071
L	0.30	0.45	0.60	0.012	0.018	0.024
L1	0.50	0.60	0.70	0.020	0.024	0.028
e	1.9 BSC			0.075 BSC		
e1	0.95 BSC			0.037 BSC		
$\theta$	0°	4°	8°	0°	4°	8°

JEDEC outline: NA