

1A Positive Voltage Regulator

Product Description

These voltage regulators are monolithic integrated circuits designed as Fixed-voltage regulators for a wide variety of applications including local, on-card regulation.

These regulators employ internal current limiting, thermal shutdown, and safe-area compensation. With adequate heat sinking they can deliver output currents in excess of 1.0 A. Although designed primarily as a fixed voltage regulator, these devices can be used with external components to obtain adjustable voltages and currents.

Features

- Output Current in Excess of 1.0 A
- No External Components Required
- Internal Thermal Overload Protection
- Internal Short Circuit Current Limiting
- Output Transistor Safe-Area Compensation
- Output Voltage Offered in 1% and 2% Tolerance
- Available in Surface Mount D²PAK and Standard 3-Lead Transistor Packages
- Previous Commercial Temperature Range has been Extended to a Junction Temperature Range of 0°C to +150°C

Packages & Pin Assignments

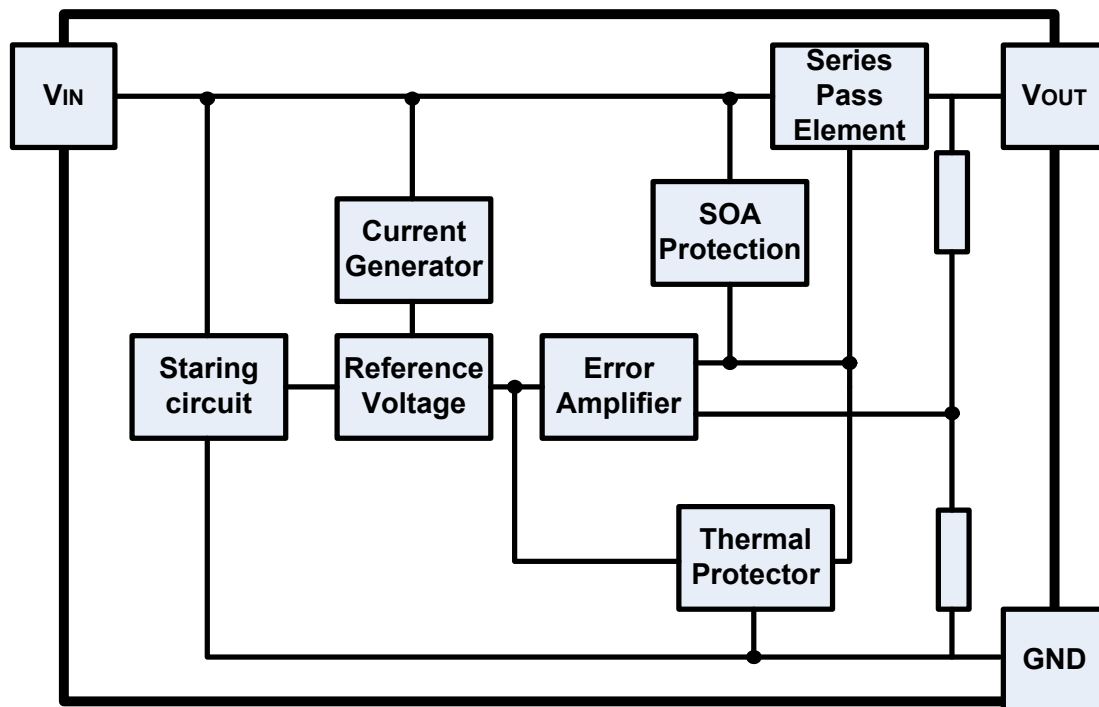

Packages & Pin Assignments

(TO-220)		(TO-263)		(TO-252)		(SOT-223)		(SOT-89)	
1	V _{IN}	1	V _{IN}	1	V _{IN}	1	V _{IN}	1	V _{IN}
2	GND	2 (TAB)	GND	2, (TAB)	GND	2, (TAB)	GND	2, (TAB)	GND
3	V _{OUT}	3	V _{OUT}	3	V _{OUT}	3	V _{OUT}	3	V _{OUT}

Ordering Information

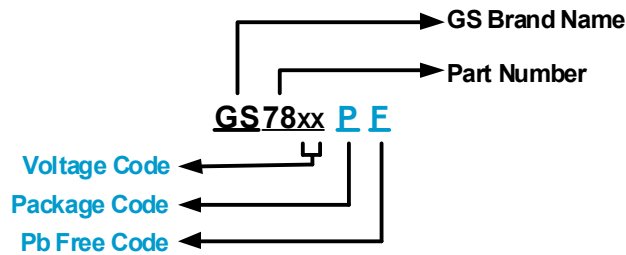

TO-220	TO-263	TO-252	SOT-223	SOT-89	Output
GS7805TF	GS7805MF	GS7805DF	GS7805XF	GS7805YF	5V
GS7808TF	GS7808MF	GS7808DF	GS7808XF	GS7808YF	8V
GS7809TF	GS7809MF	GS7809DF	GS7809XF	GS7809YF	9V
GS7810TF	GS7810MF	GS7810DF	GS7810XF	GS7810YF	10V
GS7812TF	GS7812MF	GS7812DF	GS7812XF	GS7812YF	12V

*For additional available fixed voltages, please contact factory.

Marking Information

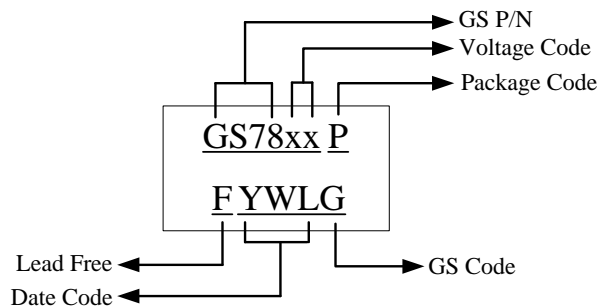

Absolute Maximum Ratings

Parameter	Symbol	Maximum	Unit	
Input Voltage	V_{IN}	35	V	
Continuous total dissipation at 25°C free-air temperature	P_D	TO-220	2	W
		TO-263	2	
		TO-252	1.2	
		SOT-223	0.9	
		SOT-89	0.5	
Thermal Resistance Junction to Ambient	θ_{JA}	TO-220	62.5	°C/W
		TO-263	62.5	
		TO-252	104	
		SOT-223	138	
		SOT-89	250	
Operating Junction Temperature Range	T_J	0 to 150	°C	
Storage temperature Range	T_{STG}	-65 to 150	°C	
Lead Temperature (Soldering 10 seconds)	T_{LEAD}	260	°C	

Caution: Stress above the listed absolute maximum rating may cause permanent damage to the device

Recommended Operating Conditions

Parameter	Part number	Min.	Max.	Unit
Input Voltage	GS7805	7	25	V
	GS7808	10.5	25	
	GS7809	11.5	27	
	GS7810	12.5	28	
	GS7812	14.5	30	
Output Current	All	-	1	A
Operating Virtual Junction Temperature	All	0	125	°C

Electrical Characteristics

($V_{IN}=10V$, $I_O=500A$, $T_J=+25^\circ C$, unless otherwise noted.)

Parameter	Symbol	Test Conditions	GS7805			Unit
			Min	Typ	Max	
Output Voltage	V_O	$5.0mA \leq I_O \leq 1.0A$, $7V \leq V_{IN} \leq 20V$	4.75	5	5.25	V
Line Regulation	Reg_{line}	$7V \leq V_{IN} \leq 25V$		3	100	mV
		$8V \leq V_{IN} \leq 12V$		1	50	
Load Regulation	Reg_{load}	$5.0mA \leq I_O \leq 1.5A$		15	100	mV
		$250mA \leq I_O \leq 750mA$		5	50	
Bias Current	I_B			4.2	8	mA
Bias Current Change	ΔI_B	$7V \leq V_{IN} \leq 25V$			1.3	mA
		$5.0mA \leq I_O \leq 1.0A$			0.5	
Ripple Rejection	RR	$8.0V \leq V_{IN} \leq 18V$, $f=120Hz$	62	78		dB
Dropout Voltage	$V_I - V_O$	$I_O=1.0A$, $T_A=25^\circ C$		2.0		V
Output Noise Voltage	V_N	$10Hz \leq f \leq 100kHz$		40		$\mu V/V_O$
Output Resistance	R_O	$f=1.0kHz$		0.017		Ω
Short-Circuit Output Current	I_{SC}			750		mA
Peak Output Current	I_{max}			2.2		A
Temperature Coefficient of Output Voltage	TCV_O	$I_O = 5.0mA$		-1.1		$mV/^\circ C$

Electrical Characteristics (Continue)

(V_{IN}=14V, I_O=500A, T_J=+25°C, unless otherwise noted.)

Parameter	Symbol	Test Conditions	GS7808			Unit
			Min	Typ	Max	
Output Voltage	V _O	5.0mA ≤ I _O ≤ 1.0A, 10.5V ≤ V _{IN} ≤ 23V	7.6	8	8.4	V
Line Regulation	Reg _{line}	10.5V ≤ V _{IN} ≤ 25V		6	160	mV
		11V ≤ V _{IN} ≤ 17V		2	80	
Load Regulation	Reg _{load}	5.0mA ≤ I _O ≤ 1.5A		12	160	mV
		250mA ≤ I _O ≤ 750mA		4	80	
Bias Current	I _B			4.3	8	mA
Bias Current Change	ΔI _B	10.5V ≤ V _{IN} ≤ 25V			1	mA
		5.0mA ≤ I _O ≤ 1.0A			0.5	
Ripple Rejection	RR	11.5V ≤ V _{IN} ≤ 21.5V, f=120Hz	55	72		dB
Dropout Voltage	V _I -V _O	I _O =1.0A, T _A =25°C		2.0		V
Output Noise Voltage	V _N	10Hz ≤ f ≤ 100kHz		52		μV
Output Resistance	R _O	f=1.0kHz		0.016		Ω
Short-Circuit Output Current	I _{SC}			450		mA
Peak Output Current	I _{max}			2.2		A
Temperature Coefficient of Output Voltage	TCV _O	I _O = 5.0mA		-0.8		mV/°C

(V_{IN}=16V, I_O=500A, T_J=+25°C, unless otherwise noted.)

Parameter	Symbol	Test Conditions	GS7809			Unit
			Min	Typ	Max	
Output Voltage	V _O	5.0mA ≤ I _O ≤ 1.0A, 11.5V ≤ V _{IN} ≤ 24V	8.55	9	9.45	V
Line Regulation	Reg _{line}	11.5V ≤ V _{IN} ≤ 27V		7	180	mV
		13V ≤ V _{IN} ≤ 19V		2	90	
Load Regulation	Reg _{load}	5.0mA ≤ I _O ≤ 1.5A		12	180	mV
		250mA ≤ I _O ≤ 750mA		4	90	
Bias Current	I _B			4.3	8	mA
Bias Current Change	ΔI _B	11V ≤ V _{IN} ≤ 27V			1	mA
		5.0mA ≤ I _O ≤ 1.0A			0.5	
Ripple Rejection	RR	12V ≤ V _{IN} ≤ 22V, f=120Hz	55	70		dB
Dropout Voltage	V _I -V _O	I _O =1.0A, T _A =25°C		2.0		V
Output Noise Voltage	V _N	10Hz ≤ f ≤ 100kHz		60		μV
Output Resistance	R _O	f=1.0kHz		0.018		Ω
Short-Circuit Output Current	I _{SC}			400		mA
Peak Output Current	I _{max}			2.2		A
Temperature Coefficient of Output Voltage	TCV _O	I _O = 5.0mA		-1.0		mV/°C

Electrical Characteristics (Continue)

(V_{IN}=17V, I_O=500A, T_J=+25°C, unless otherwise noted.)

Parameter	Symbol	Test Conditions	GS7810			Unit
			Min	Typ	Max	
Output Voltage	V _O	5.0mA ≤ I _O ≤ 1.0A, 12.5V ≤ V _{IN} ≤ 25V	9.6	10	10.4	V
Line Regulation	Reg _{line}	12.5V ≤ V _{IN} ≤ 28V		7	200	mV
		14V ≤ V _{IN} ≤ 20V		2	100	
Load Regulation	Reg _{load}	5.0mA ≤ I _O ≤ 1.5A		12	200	mV
		250mA ≤ I _O ≤ 750mA		4	100	
Bias Current	I _B			4.3	8	mA
Bias Current Change	ΔI _B	12.5V ≤ V _{IN} ≤ 28V			1	mA
		5.0mA ≤ I _O ≤ 1.0A			0.5	
Ripple Rejection	RR	13V ≤ V _{IN} ≤ 23V, f=120Hz	55	71		dB
Dropout Voltage	V _I -V _O	I _O =1.0A, T _A =25°C		2.0		V
Output Noise Voltage	V _N	10Hz ≤ f ≤ 100kHz		70		μV
Output Resistance	R _O	f=1.0kHz		0.018		Ω
Short-Circuit Output Current	I _{SC}			400		mA
Peak Output Current	I _{max}			2.2		A
Temperature Coefficient of Output Voltage	TCV _O	I _O = 5.0mA		-1.0		mV/°C

(V_{IN}=23V, I_O=500A, T_J=+25°C, unless otherwise noted.)

Parameter	Symbol	Test Conditions	GS7812			Unit
			Min	Typ	Max	
Output Voltage	V _O	5.0mA ≤ I _O ≤ 1.0A, 17.5V ≤ V _{IN} ≤ 30V	14.4	15	15.6	V
Line Regulation	Reg _{line}	17.5V ≤ V _{IN} ≤ 30V		12	300	mV
		20V ≤ V _{IN} ≤ 26V		3	150	
Load Regulation	Reg _{load}	5.0mA ≤ I _O ≤ 1.5A		12	300	mV
		250mA ≤ I _O ≤ 750mA		4	150	
Bias Current	I _B			4.3	8	mA
Bias Current Change	ΔI _B	17.5V ≤ V _{IN} ≤ 30V			1	mA
		5.0mA ≤ I _O ≤ 1.0A			0.5	
Ripple Rejection	RR	18.5V ≤ V _{IN} ≤ 28.5V, f=120Hz	54	70		dB
Dropout Voltage	V _I -V _O	I _O =1.0A, T _A =25°C		2.0		V
Output Noise Voltage	V _N	10Hz ≤ f ≤ 100kHz		90		μV
Output Resistance	R _O	f=1.0kHz		0.019		Ω
Short-Circuit Output Current	I _{SC}			230		mA
Peak Output Current	I _{max}			2.2		A
Temperature Coefficient of Output Voltage	TCV _O	I _O = 5.0mA		-1.0		mV/°C

NOTES:

* Pulse testing techniques are used to maintain the junction temperature as close to the ambient temperature as possible. Thermal effects must be taken into account separately.

** This specification applies only for dc power dissipation permitted by absolute maximum ratings

Applications Information (Design Considerations)

The GS78xx Series of fixed voltage regulators are designed with Thermal Overload Protection that shuts down the circuit when subjected to an excessive power overload condition, Internal Short Circuit Protection that limits the maximum current the circuit will pass, and Output Transistor Safe-Area Compensation that reduces the output short circuit current as the voltage across the pass transistor is increased. In many low current applications, compensation capacitors are not required. However, it is recommended that the regulator input be bypassed with a capacitor if the regulator is connected to the power supply filter with long wire lengths, or if the output load capacitance is large. An input bypass capacitor should be selected to provide good high-frequency characteristics to insure stable operation under all load conditions. A 0.33 μF or larger tantalum, mylar, or other capacitor having low internal impedance at high frequencies should be chosen. The bypass capacitor should be mounted with the shortest possible leads directly across the regulators input terminals. Normally good construction techniques should be used to minimize ground loops and lead resistance drops since the regulator has no external sense lead.

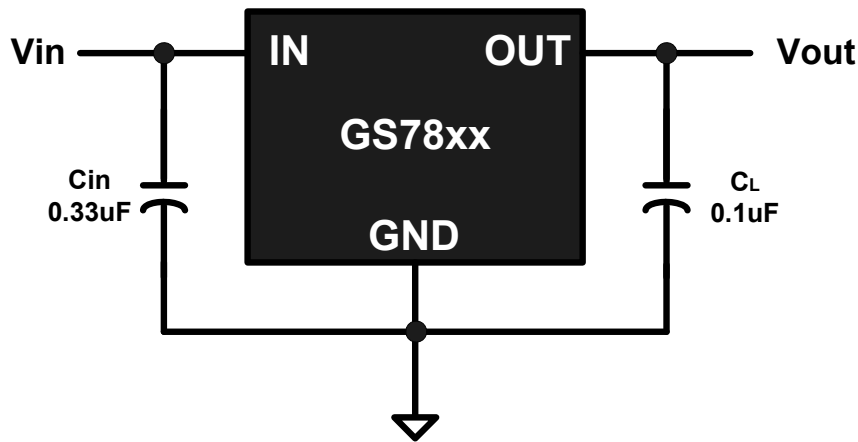

Package Dimension

TO-263 PLASTIC PACKAGE

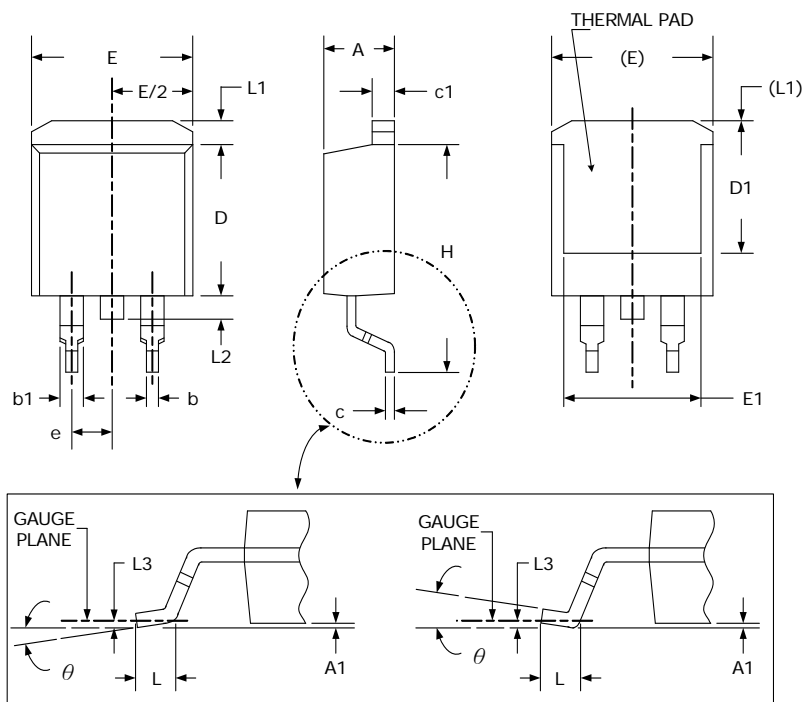

Dimensions				
SYMBOL	Millimeters		Inches	
	MIN	MAX	MIN	MAX
A	4.06	4.83	.160	.190
A1	0	0.25	.000	.010
b	0.51	0.99	.020	.039
b1	1.14	1.78	.045	.070
c	0.38	0.74	.015	.029
c1	1.14	1.65	.045	.065
D	8.38	9.65	.330	.380
D1	6.86	-	.270	-
E	9.65	10.67	.380	.420
E1	6.22	-	.245	-
e	2.54 (TYP)		.100 (TYP)	
H	14.61	15.88	.575	.625
L	1.78	2.79	.070	.110
L1	-	1.68	-	.066
L2	-	1.78	-	.070
L3	0.25 (TYP)		.010 (TYP)	
θ	0°	8°	0°	8°

TO-252 PLASTIC PACKAGE

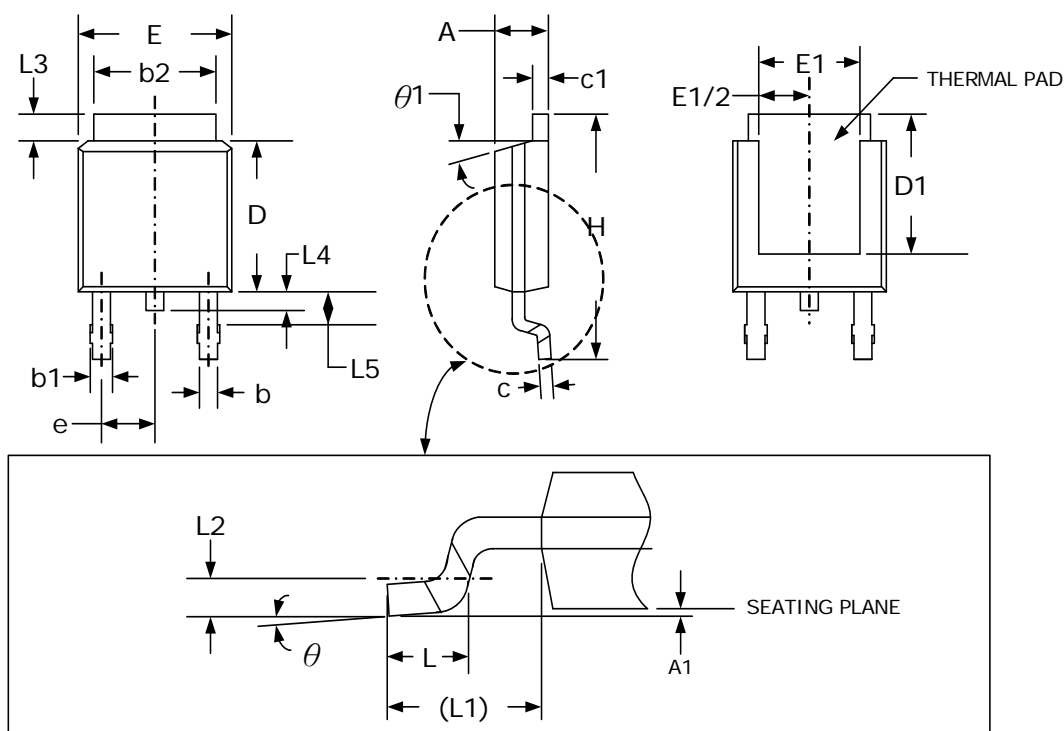

Dimensions

SYMBOL	Millimeters		Inches	
	MIN	MAX	MIN	MAX
A	2.18	2.39	.086	.094
A1	-	0.13	-	.005
b	0.64	0.89	.025	.035
b1	0.76	1.14	.030	.045
b2	4.95	5.46	.195	.215
C	0.46	0.61	.018	.024
C1	0.46	0.89	.018	.035
D	5.97	6.22	.235	.245
D1	5.21	-	.205	-
E	6.35	6.73	.250	.265
E1	4.32	-	.170	-
e	2.29 (TYP)		.090 (TYP)	
H	9.40	10.41	.370	.410
L	1.40	1.78	.055	.070
L1	2.74 (TYP)		.108 (TYP)	
L2	0.51 (TYP)		.020 (TYP)	
L3	0.89	1.27	.035	.050
L4	-	1.02	-	.040
L5	1.14	1.52	.045	.060
θ	0°	10°	0°	10°
$\theta 1$	0°	15°	0°	15°

SOT-223 PLASTIC PACKAGE

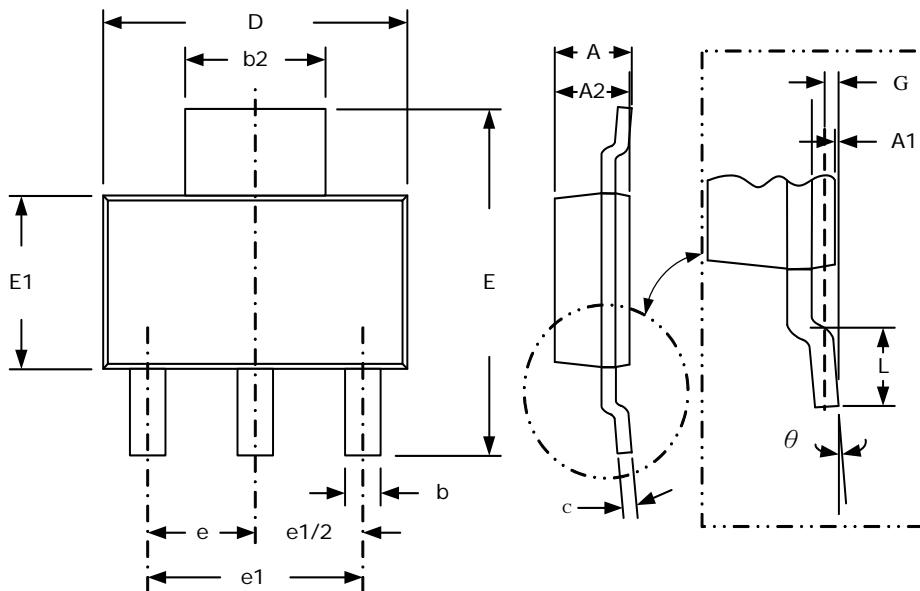

Dimensions				
SYMBOL	Millimeters		Inches	
	MIN	MAX	MIN	MAX
A	-	1.80	-	.071
A1	0.02	0.10	.001	.004
A2	1.55	1.65	.061	.065
b	0.66	0.84	.026	.033
b2	2.90	3.10	.114	.122
c	0.23	0.33	.009	.013
D	6.30	6.70	.248	.264
E	6.70	7.30	.264	.288
E1	3.30	3.70	.130	.146
e	2.30 (TYP)		.091 (TYP)	
e1	4.60 (TYP)		.181 (TYP)	
L	0.90	-	.035	-
G	0.25 (TYP)		.010 (TYP)	
θ	0°	8°	0°	8°

SOT-89 PLASTIC PACKAGE

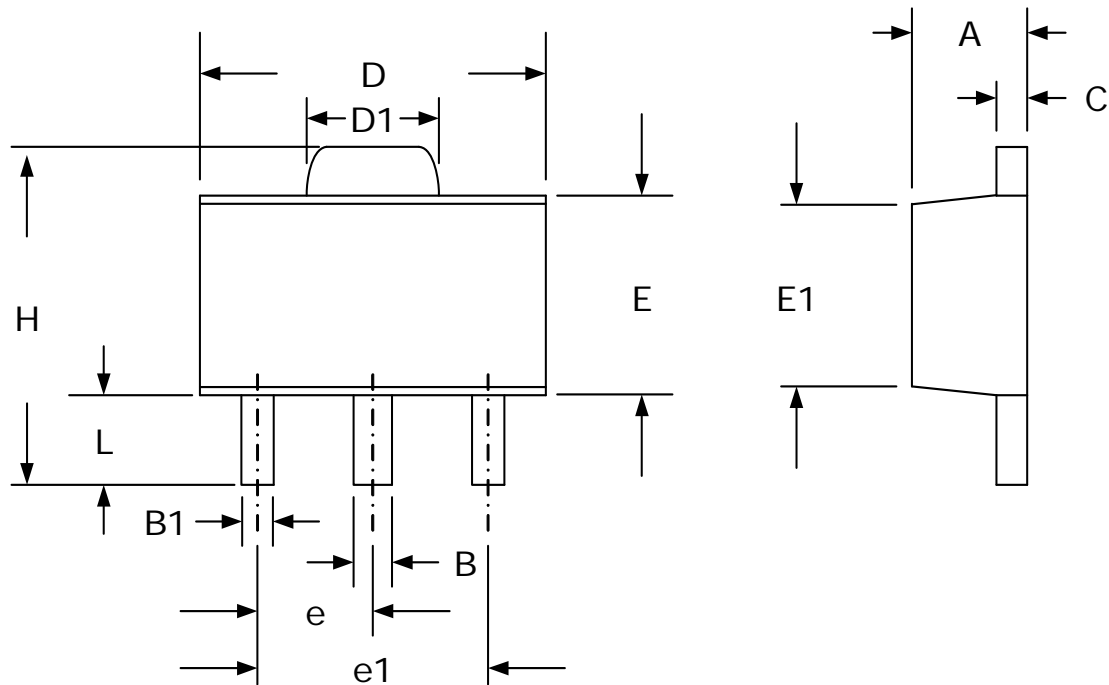

Dimensions				
SYMBOL	Millimeters		Inches	
	MIN	MAX	MIN	MAX
A	1.40	1.60	.055	.063
B	0.44	0.56	.017	.022
B1	0.36	0.48	.014	.019
C	0.35	0.44	.014	.017
D	4.40	4.60	.173	.181
D1	1.62	1.83	.064	.072
E	2.29	2.60	.090	.102
E1	2.13	2.29	.084	.090
e	1.50 (TYP)		.059 (TYP)	
e1	3.00 (TYP)		.118 (TYP)	
H	3.94	4.25	.155	.167
L	0.89	1.20	.035	.047

TO-220 PLASTIC PACKAGE

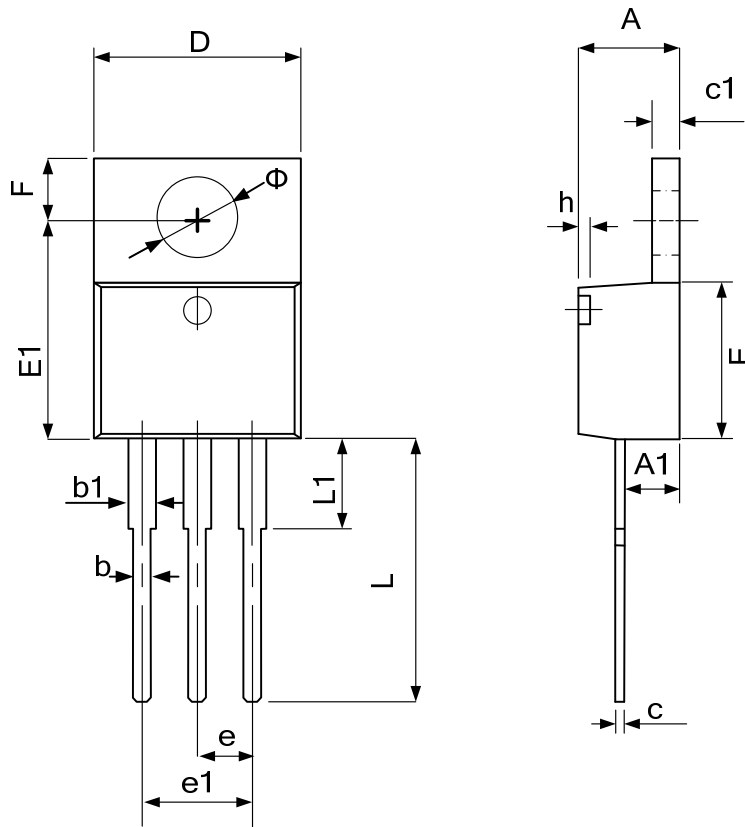

Dimensions				
SYMBOL	Millimeters		Inches	
	MIN	MAX	MIN	MAX
A	4.47	4.67	.176	.184
A1	2.52	2.82	.099	.111
b	0.71	0.91	.028	.036
b1	1.17	1.37	.046	.054
c	0.31	0.53	.012	.021
c1	1.17	1.37	.046	.054
D	10.01	10.31	.394	.406
E	8.50	8.90	.335	.350
E1	12.06	12.46	.475	.491
e	2.540 (TYP)		0.1(TYP)	
e1	4.98	5.18	.196	.204
F	2.59	2.89	.102	.114
h	0.0	0.30	0.0	.012
L	13.40	13.80	.528	.543
L1	3.56	3.96	.140	.156
Φ	3.735	3.935	.147	.155

NOTICE

Information furnished is believed to be accurate and reliable. However Globaltech Semiconductor assumes no responsibility for the consequences of use of such information nor for any infringement of patents or other rights of third parties, which may result from its use. No license is granted by implication or otherwise under any patent or patent rights of Globaltech Semiconductor. Specifications mentioned in this publication are subject to change without notice. This publication supersedes and replaces all information without express written approval of Globaltech Semiconductor.

(Revise Date:2007/11/13 Version_1.0)
